

# EG3014 Datasheet

Half-Bridge Driver

## Contents

1. Features .....	2
2. General Description .....	2
3. Applications .....	2
4. Device Information .....	3
4.1. Pin map .....	3
4.2. Pin Functions.....	3
5. Block Diagram .....	4
6. Application Schematics .....	4
7. Electrical Characteristics .....	6
7.1 Absolute maximum ratings .....	6
7.2 Recommended operating conditions.....	7
7.3 Timing Diagram.....	8
8. Function Description.....	9
8.1 Supply voltage and UVLO.....	9
8.2 Input stage and Output stage .....	9
8.3 Bootstrap .....	10
9. Package Information .....	11
9.1 SOP8 Dimension.....	11

# EG3014 Datasheet V1.0

## 1. Features

---

- Floating high side driver in bootstrap operation to +100V, build in bootstrap diode
- Internal fixed dead time of 120nS
- Cross-conduction prevention logic
- 800mA source/1000mA sink output current capability
- Driving N-channel MOSFETs and IGBTs in a half-bridge configuration
- High side output in phase with HIN input
- Low side output in phase with LIN input
- Minimal peripheral components
- Low quiescent current: 4.5mA
- Package: SOP8

## 2. General Description

---

The EG3014 is a cost effective half-bridge driver IC designed for N-channel MOSFETs and IGBTs.

The EG3014 includes a combined logic inputs for low and high-side drives, fixed dead time to protect FETs , cross-conduction prevention logic, high voltage level shifter, noise filter enhanced immunity, and provide high current capability for external N-channel MOSFETs, application for brushless motor drives.

The bootstrap operation voltage of EG3014 is up to 100VDC, the operation voltage of Vcc is between 4.5V to 30V, and quiescent supply current is only 4.5mA. Build in simultaneous conduction lockout protection, and build in pull down resistors of 10K on all the input pins( HIN, LIN), when input pins are floating, the HO and LO are held to low, the structure of high current Darlington is used in output stage, the EG3012 is available in a SOP8 package.

## 3. Applications

---

- E-bike controller
- 100V synchronous Buck converter
- Class D power amplifies
- Brushless pump controller
- BLDC Motor drive

## 4. Device Information

### 4.1. Pin map

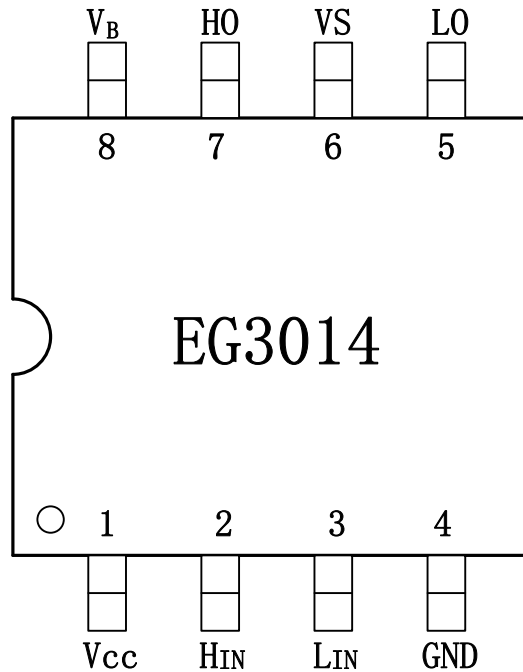

Figure 4-1. EG3014 pin map

### 4.2. Pin Functions

Designator	Name	I/O	Descriptions
1	Vcc	Power	Supply voltage
2	HIN	I	Logic input for high side gate driver output, in phase
3	LIN	I	Logic input for low side gate driver output, in phase
4	GND	GND	Ground
5	LO	O	Output gate driver for low side MOSFET
6	VS	O	High side bootstrap return
7	HO	O	Output gate driver for high side MOSFET
8	VB	Power	Bootstrap supply voltage

# 5. Block Diagram

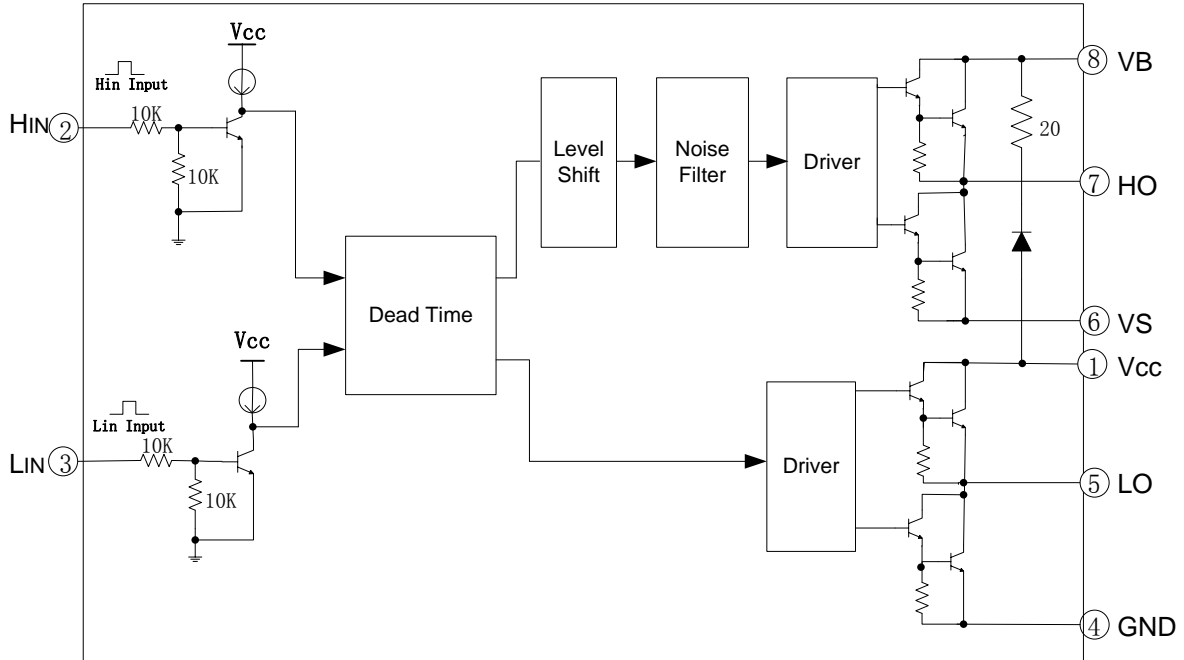

Fig 5-1. EG3014 block diagram

# 6. Application Schematics

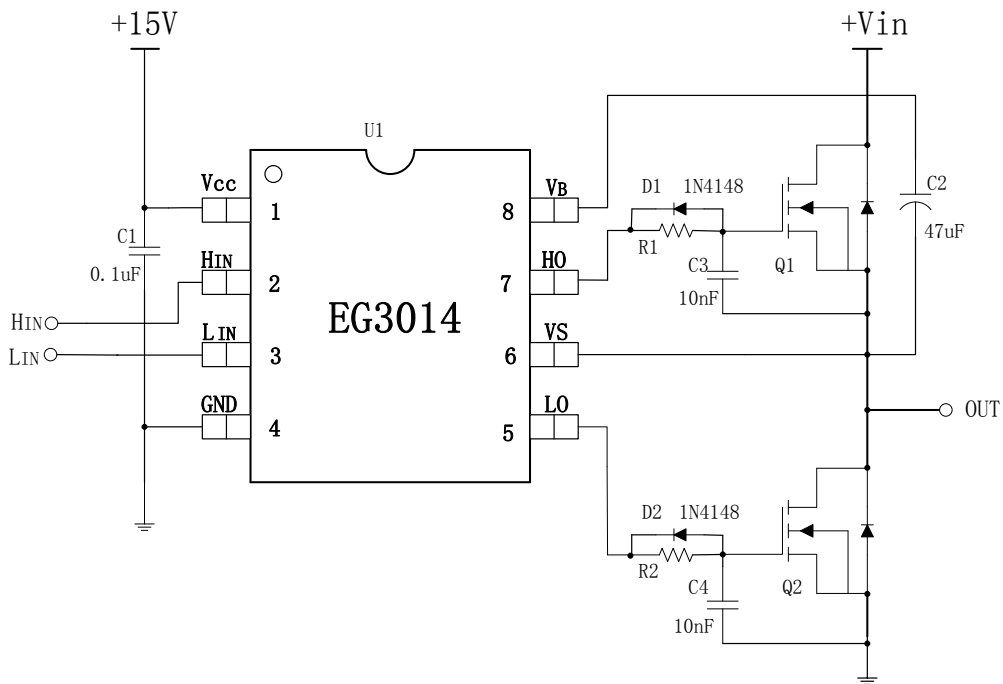

Fig 6-1. EG3014 typical application schematic I for middle power motor

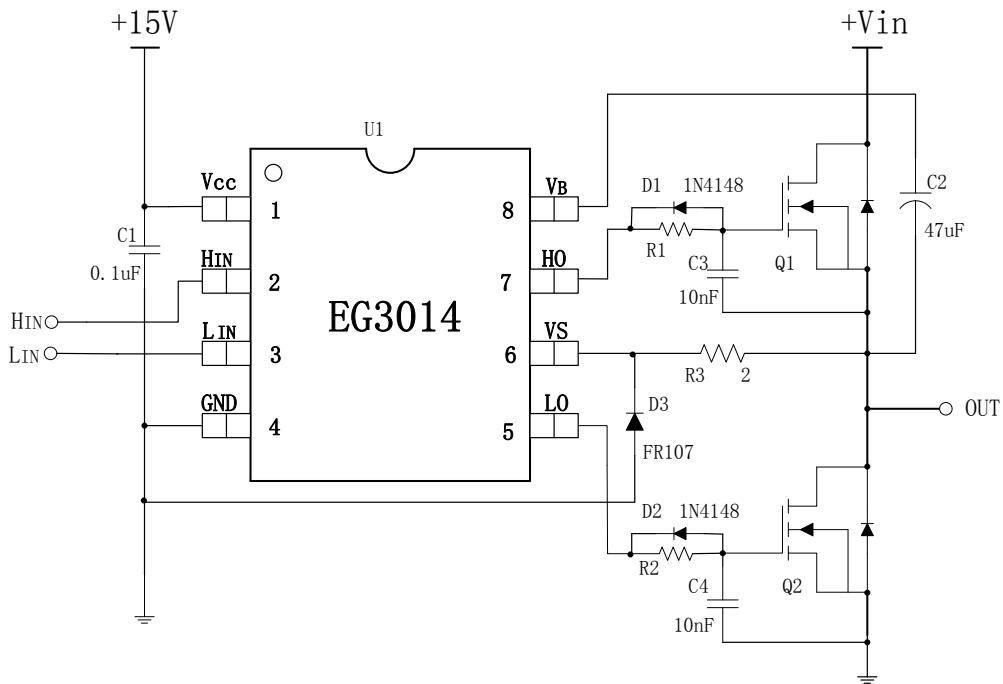

Fig 6-2. EG3014 typical application schematic II for high power motor

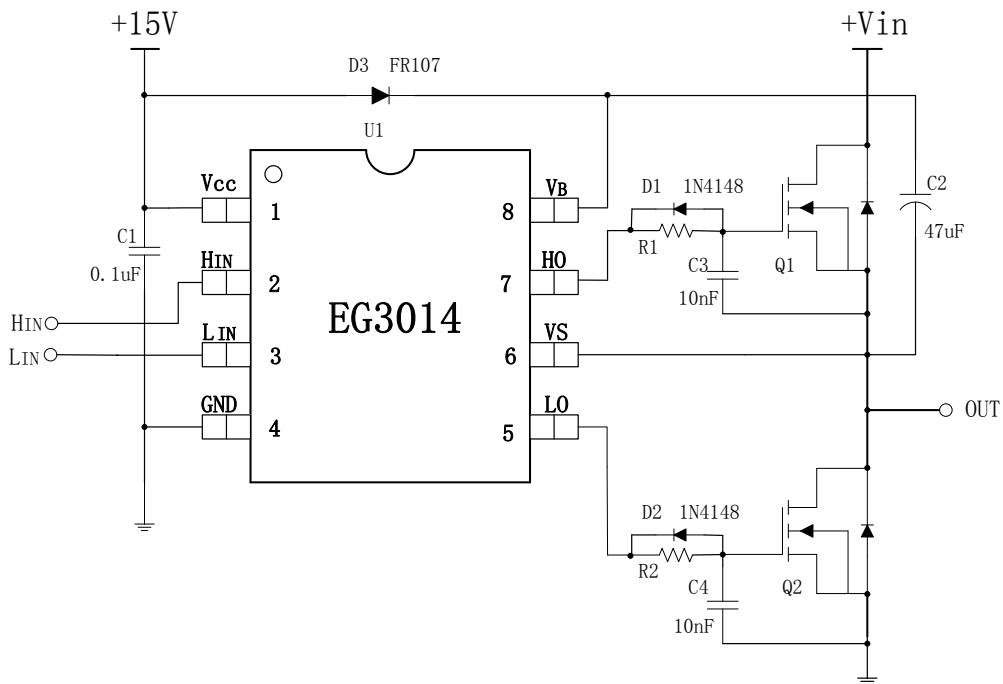

Fig 6-3. EG3014 typical application schematic III for external bootstrap diode

## 7. Electrical Characteristics

### 7.1 Absolute maximum ratings

TA=25°C unless otherwise specified

Symbol	Parameter	Conditions	Min	Max	Unit
VB	Bootstrap supply	-	-0.3	100	V
VS	Bootstrap return	-	-0.7	100	V
HO	High side drive output	-	-0.3	100	V
LO	Low side drive output	-	-0.3	35	V
VCC	Supply voltage	-	-0.3	35	V
HIN	High side input	-	-0.3	35	V
LIN	Low side input	-	-0.3	35	V
TA	Ambient temperature	-	-45	85	°C
Tstr	Storage temperature	-	-65	125	°C
TL	Lead temperature	T=10S	-	300	°C

Note: Exceeding extreme conditions may permanently damage the chip. EG3014's reliability may be affected running at the extreme conditions for a long time.

## 7.2 Recommended operating conditions

TA=25°C, Vcc=15V, CL=10nF, unless otherwise specified

Parameter	Symbol	Conditions	Min	TYP	Max	Unit
Supply voltage	Vcc	-	4.5	15	30	V
Quiescent current	Icc	All input pins is floating, Vcc=15V	-	4.5	6	mA
Logic "1" input voltage	Vin(H)	HIN & LIN	2.5	5.0	-	V
Logic "0" input voltage	Vin(L)	HIN & LIN	-0.3	0	1.0	V
Logic "1" input bias current	Iin(H)	Vin=5V	-	300	400	uA
Logic "0" input bias current	Iin(L)	Vin=0V	-	0	-	uA
<b>Switching time characteristics for LO</b>						
Turn on propagation delay	Ton	See the Figure7-1	-	500	700	nS
Turn off propagation delay	Toff	See the Figure7-1	-	50	100	nS
Turn on rise time	Tr	See the Figure7-1	-	400	600	nS
Turn off fall time	Tf	See the Figure7-1	-	200	300	nS
<b>Switching time characteristics for HO</b>						
Turn on propagation delay	Ton	See the Figure7-2	-	300	500	nS
Turn off propagation delay	Toff	See the Figure7-2	-	400	600	nS
Turn on rise time	Tr	See the Figure7-2	-	400	600	nS
Turn off fall time	Tf	See the Figure7-2	-	200	300	nS
<b>Dead time</b>						
Dead time	DT	See the Figure7-3, and CL=0	80	120	400	nS
<b>Drive Capability</b>						
Output high short circuit pulsed current	IO+	Vo=0V, VIN=VIH PW≤10uS	0.6	0.8	-	A
Output low short circuit pulsed current	IO-	Vo=15V, VIN=VIL PW≤10uS	0.8	1	-	A



### 7.3 Timing Diagram

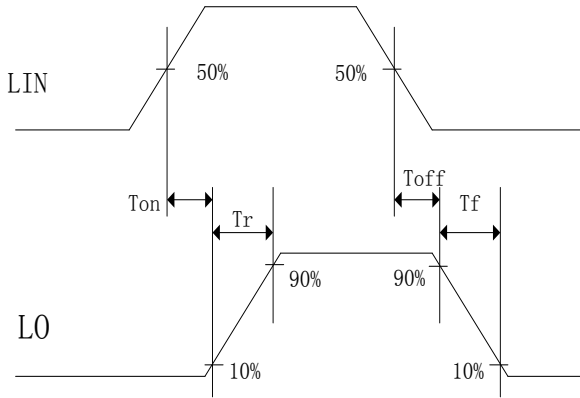

Figure7-1. Switching time waveform definitions of LO

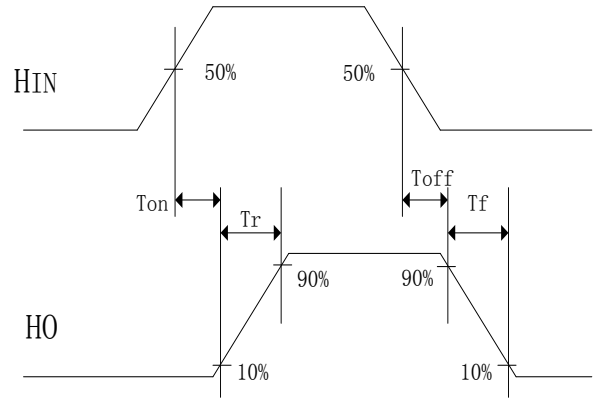

Figure7-2. Switching time waveform definitions of HO

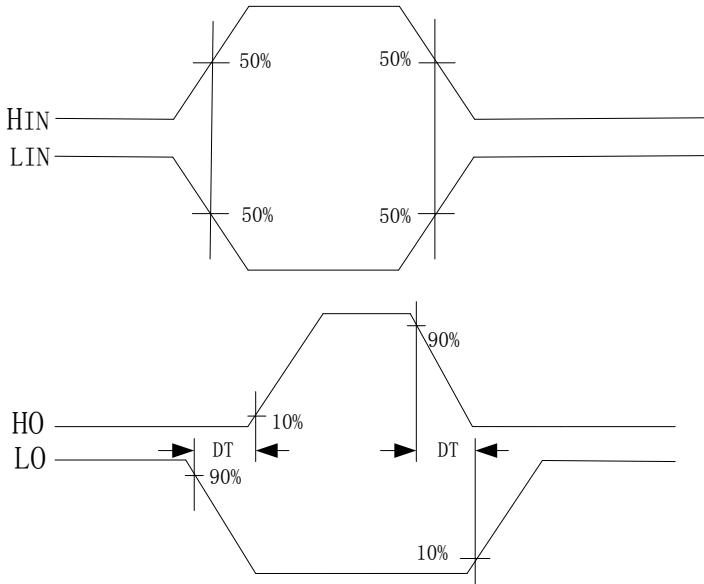

Figure7-3. Dead time waveform definitions

# 8. Function Description

## 8.1 Supply voltage

When considering there is enough driving voltage to drive the power MOSFET, the recommended VCC operating voltage of EG3012 is between 12V to 15V.

The internal logic circuit and driver stage of EG3012 share the VCC power supply, the internal ground of logic circuit and driver stage are also connected together.

## 8.2 Input stage and Output stage

The EG3014 includes a combines logic inputs, dead time, high voltage level shifter, bootstrap circuit, high current Darlington output stage. the input pins of EG3014 features typical high threshold of 2.5V and typical low threshold of 1.0V, the input pins are conveniently drive with logic level PWM control signals from MCU digital controller device.

Each output stage in EG3014 is capable of supplying 0.8A peak source and 1A peak sink current, floating high side driver in bootstrap operation is up to 100VDC.

The EG3014 features excellent propagation delay between input and output. In low side driver, with 500ns turn on propagation delay is over LIN to LO, with 50ns turn off propagation delay is over LIN to LO. In high side driver, with 300ns turn on propagation delay is over HIN to HO, with 400ns turn off propagation delay is over HIN to HO.

Input/Output Logic Relationship as shown in Figure 8-2:

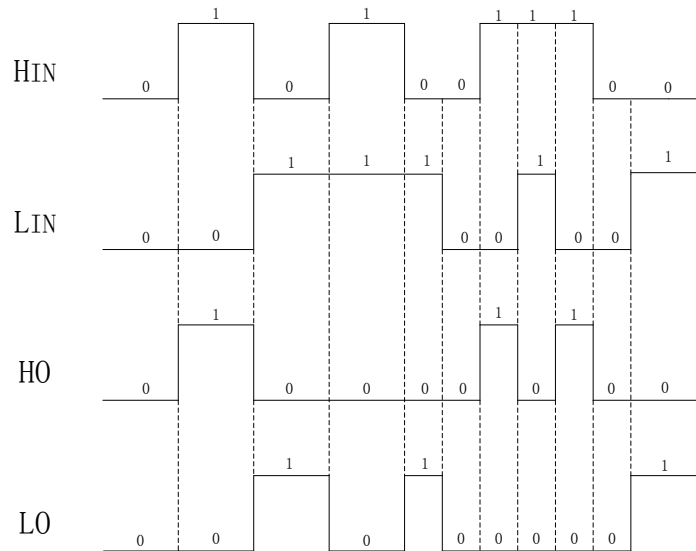

Figure 8-2. Input/Output logic relationship

Input/Output Logic Table:

Input		Output	
HIN(Pin4)	LIN (Pin3)	HO(Pin7)	LO (Pin5)
<b>0</b>	<b>0</b>	0	0
0	1	0	1
1	0	1	0
<b>1</b>	<b>1</b>	0	0

From above logic table view, Case A: when HIN goes high and LIN goes low, HO will output high to turn on high side MOSFET and LO will output low to turn off low side MOSFET. Case B: when HIN goes low and LIN goes high, HO will output low to turn off high side MOSFET and LO will output high to turn on low side MOSFET. Case C: when both of HIN and LIN are low or high at same time, interlock and dead time functions prevent both outputs from being turned on simultaneously.

### 8.3 Bootstrap

The EG3014 uses a bootstrap structure, which has the advantage of being simply and low cost. The Figure 8-3 will help to understand the operation of bootstrap circuit. The voltage at VCC forces current through the internal bootstrap diode or external bootstrap diode, bootstrap capacitor and low side MOSFET, which will charge the bootstrap capacitor to prepare it for driving the high side MOSFET.

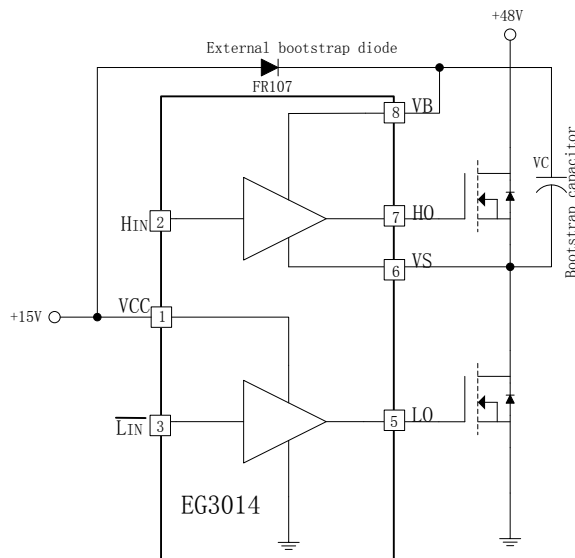

Figure 8-3. EG3014 Bootstrap circuit structure

# 9. Package Information

## 9.1 SOP8 Dimension

