

FEATURES

- Available in glass passivated chip junction with G suffix
- Low forward voltage drop
- High current capability
- Low leakage current
- Super fast switching speed < 35ns

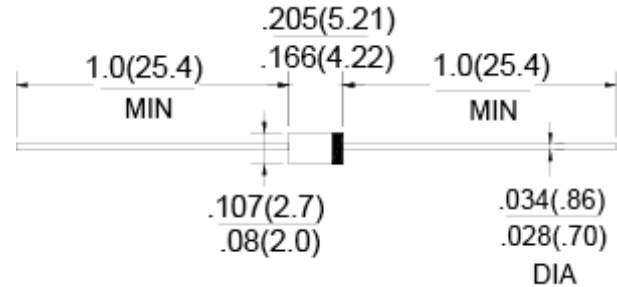

MECHANICAL DATA

- Molded plastic body (UL 94V-0 rated)
- Lead: Axial leads, solderable per MIL-STD-202, Method 208
- Polarity: Color band denotes cathode end
- Weight: 0.34 gram

DO-41 (DO204-AL)
Dimensions in millimeters

MAXIMUM RATINGS & ELECTRICAL CHARACTERISTICS

Rating at 25°C ambient temperature unless otherwise specified.
Single phase, half wave, 60Hz, resistive or inductive load.
For capacitive load, derate current by 20%

Parameter	Symbol	SF11(G)	SF12(G)	SF13(G)	SF14(G)	SF15(G)	SF16(G)	SF17(G)	SF18(G)	Unit
		EGP10A	EGP10B	EGP10C	EGP10D	EGP10F	EGP10G		EGP10J	
Maximum Repetitive Peak Reverse Voltage	V _{RRM}	50	100	150	200	300	400	500	600	V
Maximum RMS Voltage	V _{RMS}	35	70	105	140	210	280	350	420	V
Maximum DC blocking Voltage	V _{DC}	50	100	150	200	300	400	500	600	V
Maximum Average Forward Rectified Current .375" (9.5mm) Lead length @ T _A =55°C	I _{F(AV)}	1.0								A
Peak Forward Surge Current 8.3ms single half sine-wave superimposed on rated load (JEDEC method)	I _{FSM}	30								A
Maximum Instantaneous Forward Voltage @ 3.0A	V _F	0.95			1.3		1.7			V
Maximum DC Reverse Current @ T _A =25°C at rated DC Blocking voltage @ T _A =125°C	I _R	5.0								μA
Maximum Reverse Recovery Time (Note 1)	T _{RR}	35								nS
Typical Thermal Resistance (Note 2)	R _{θJA}	55								°C/W
Operating Temperature Range	T _J	-55 to + 125/-55 to +150 for (G)								°C
Storage Temperature Range	T _{STG}	-55 to + 150								°C

NOTE: 1.Reverse Recovery Test conditions: I_F=0.5A, I_R=1.0A, I_{RR}=0.25A.
2.Mounted on Cu-Pad Size 5.0mm x 5.0 mm on P.C.B.

RATING & CHARACTERISTIC CURVES

FIG.1-MAXIMUM NON-REPETITIVE FORWARD SURGE CURRENT

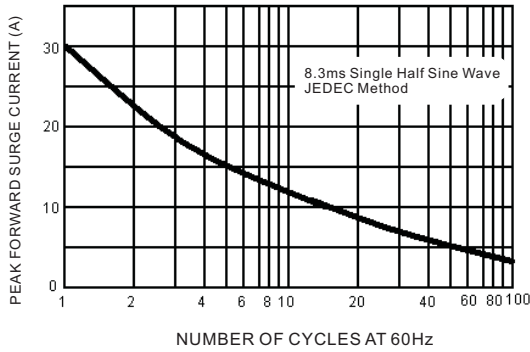

FIG.2-MAXIMUM FORWARD CURRENT DERATING

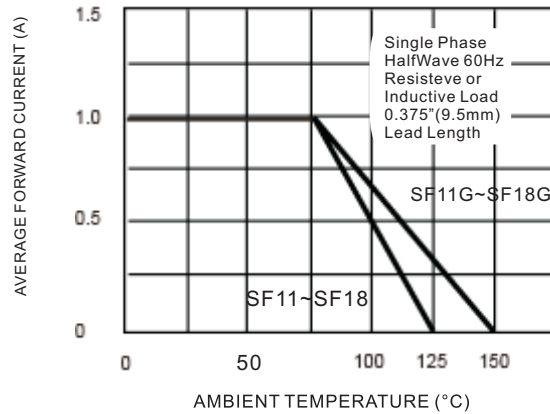

FIG.3-TYPICAL INSTANTANEOUS FORWARD CHARACTERISTICS

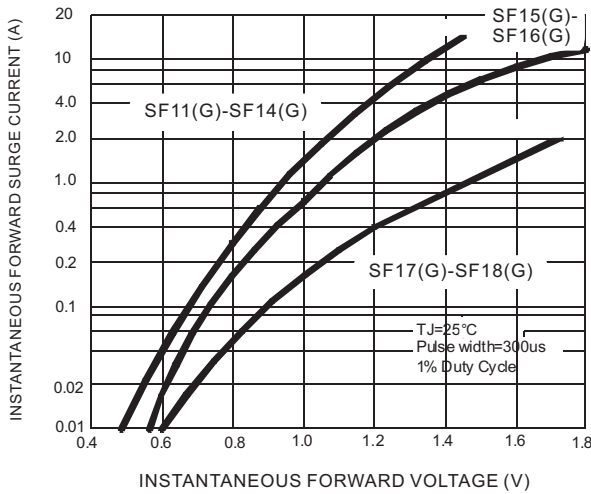

FIG.4-TYPICAL REVERSE CHARACTERISTICS

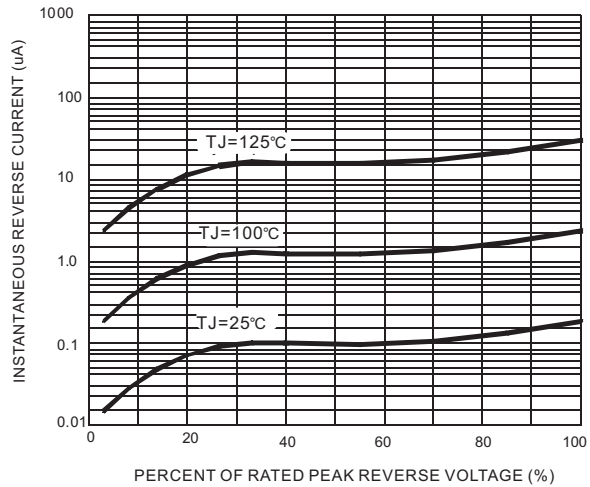
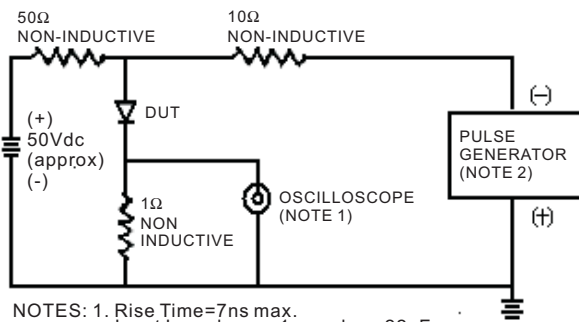

FIG.5-REVERSE RECOVER TIME CHARACTERISTIC AND TEST CIRCUIT DIAGRAM



NOTES: 1. Rise Time=7ns max.
Input Impedance=1megohm 22pF
2. Rise Time=10ns max.
Source Impedance=50 ohms.

