

# **INNOLUX DISPLAY CORPORATION**

## **LCD MODULE**

# **SPECIFICATION**

**Customer:** \_\_\_\_\_

**Model Name:** EJ101IA-01G

**Date:** 2017/11/17

**Version:** 07

**Preliminary Specification**

**Final Specification**

**For Customer's Acceptance**

Approved by	Comment

Approved by	Reviewed by	Prepared by

## Record of Revision

Version	Revise Date	Page	Content
Pre-Spec.01	2012/11/13	All	Initial Release
Fin-Spec.01	2013/05/27	1	Update Backlight & Panel power consumption& Weight
		4	Update 3.1.1 Current Consumption
		6	Update Vcom
		7	Modify Power Sequence
		8	Update LVDS Differential voltage min Values
		9	Update Timing Table
		11	Update Test conditions 1
		17	Modify Mechanical Drawing
		19	Modify Package Drawing
Fin-Spec.02	2014/01/24	1	Update Backlight power consumption
		2	Update connect type
		7	Update power sequence
		14	Update definition of Luminance Uniformity
Fin-Spec.03	2014/08/18	18	Update LCM dimensions
Fin-Spec.04	2015/01/28	5	Current for Driver
		5	Voltage for LED backlight
		5	Current for LED backlight
Fin-Spec.05	2015/06/29	17	Mechanical Drawing
		5	Current Consumption
Fin-Spec.06	2016/09/23	1	Update General Specifications
		5	Update Current Consumption
		7	Update Power Sequence
		10	Update Timing Table
		18	Modify Mechanical Drawing
Fin-Spec.06	2017/08/01	16	Modify Reliability Test Items
		20	Modify Packaging Drawing
Fin-Spec.07	2017/11/17	2	<a href="#">Modify Pin Assignment Description</a>
		7-8	<a href="#">Modify Power Sequence</a>
		18	<a href="#">Modify Mechanical Drawing</a>

## Contents

1. General Specifications .....	1
2. Pin Assignment .....	2
3. Operation Specifications .....	4
3.1. Absolute Maximum Ratings .....	4
3.2. Typical Operation Conditions .....	6
3.3. Power Sequence .....	7
3.4. LVDS Signal Timing Characteristics .....	8
3.4.1. AC Electrical Characteristics .....	8
3.4.2. Timing Table .....	9
3.4.3. LVDS Data Input Format .....	10
4. Optical Specifications .....	11
5. Reliability Test Items .....	15
6. General Precautions .....	16
6.1. Safety .....	16
6.2. Handling .....	16
6.3. Static Electricity .....	16
6.4. Storage .....	16
6.5. Cleaning .....	16
7. Mechanical Drawing .....	17
8. Package Drawing .....	18
8.1. Packaging Material Table .....	18
8.2. Packaging Quantity .....	18
8.3. Packaging Drawing .....	19

# 1. General Specifications

No.	Item	Specification	Remark
1	LCD size	10.1 inch(Diagonal)	
2	Driver element	a-Si TFT active matrix	
3	Resolution	1280 × 3(RGB) × 800	
4	Display mode	Normally Black, Transmissive	
5	Dot pitch	0.0565(W) × 0.1695(H) mm	
6	Active area	216.96(W) × 135.60(H) mm	
7	Module size	229.46(W) × 149.1(H) × 2.50(D) mm	Note 1
8	Surface treatment	HC	
9	Color arrangement	RGB-stripe	
10	Interface	Digital	
11	Backlight power consumption	1.76 W(Typ.)	
12	Panel power consumption	0.7W(Typ.)	Note 2
13	Weight	0.183KG(Typ.)	
14	inversion	1+2line	
15	IC	HX8288*4&HX8695*1	

Note 1: Refer to Mechanical Drawing.

Note 2: Including T-con Board power consumption

## 2. Pin Assignment

A 40pin connector is used for the module electronics interface. This model used 196479-40041-3 manufactured by P2 connector

Pin No.	Symbol	I/O	Function	Remark
1	VCOM	P	Common Voltage	
2	VDD	P	Power Supply	
3	VDD	P	Power Supply	
4	NC	---	No connection	
5	NC	---	No connection	
6	NC	---	No connection	
7	GND	P	Ground	
8	Rxin0-	I	-LVDS Differential Data Input	R0-R5, G0
9	Rxin0+	I	+LVDS Differential Data Input	
10	GND	P	Ground	
11	Rxin1-	I	-LVDS Differential Data Input	G1~G5, B0,B1
12	Rxin1+	I	+LVDS Differential Data Input	
13	GND	P	Ground	
14	Rxin2-	I	-LVDS Differential Data Input	B2-B5,HS,VS, DE
15	Rxin2+	I	+LVDS Differential Data Input	
16	GND	P	Ground	
17	RxCLK-	I	-LVDS Differential Clock Input	LVDS CLK
18	RxCLK+	I	+LVDS Differential Clock Input	
19	GND	P	Ground	
20	Rxin3-	I	-LVDS Differential Data Input	R6, R7, G6, G7, B6, B7
21	Rxin3+	I	+LVDS Differential Data Input	
22	GND	P	Ground	
23	NC	---	No connection	
24	NC	---	No connection	
25	GND	P	Ground	
26	NC	---	No connection	

27	LED_PWM	O	CABC controller signal output for backlight	Note2
28	NC	---	No connection	
29	AVDD	P	Power for Analog Circuit	
30	GND	P	Ground	
31	LED-	P	LED Cathode	
32	LED-	P	LED Cathode	
33	NC	---	No connection	
34	NC	---	No connection	
35	VGL	P	Gate OFF Voltage	
36	NC	---	No connection	
37	CABC_EN	I	CABC Enable Input	Note1
38	VGH	P	Gate ON Voltage	
39	LED+	P	LED Anode	
40	LED+	P	LED Anode	

I: input, O: output, P: Power

Note1: The setting of CABC function are as follows.

Pin	Enable	Disable
CABC_EN	High Voltage	Low Voltage or open

Note2: LED\_PWM is used to adjust backlight brightness.

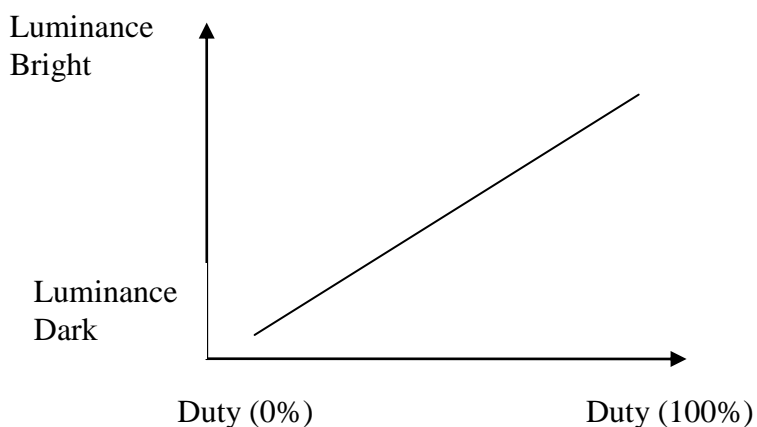

### 3. Operation Specifications

#### 3.1. Absolute Maximum Ratings

(Note 1)

Item	Symbol	Values		Unit	Remark
		Min.	Max.		
Power voltage	VDD	-0.3	3.9	V	
	AVDD	-0.3	14	V	
	V <sub>GH</sub>	-0.3	42.0	V	
	V <sub>GL</sub>	-19	0.3	V	
	V <sub>GH</sub> -V <sub>GL</sub>	12	40.0	V	
Operation Temperature	T <sub>OP</sub>	-10	50	°C	
Storage Temperature	T <sub>ST</sub>	-20	60	°C	
LED Reverse Voltage	V <sub>R</sub>	2.7	3.1	V	Each LED
LED Forward Current	I <sub>F</sub>	---	50	mA	Each LED

Note 1: The absolute maximum rating values of this product are not allowed to be exceeded at any times. Should a module be used with any of the absolute maximum ratings exceeded, the characteristics of the module may not be recovered, or in an extreme case, the module may be permanently destroyed.

**3.1.1. Current Consumption**

Item	Symbol	Values			Unit	Remark
		Min.	Typ.	Max.		
Current for Driver	$I_{GH}$	300	705	1000	uA	$V_{GH} = 22V$
	$I_{GL}$	300	705	1000	uA	$V_{GL} = -7V$
	$I_{V_{DD}}$	50	95	120	mA	$V_{DD} = 2.5V$
	$I_{AV_{DD}}$	8	45	70	mA	$AV_{DD} = 8.2V$

**3.1.2. Backlight Driving Conditions**

Item	Symbol	Values			Unit	Remark
		Min.	Typ.	Max.		
Voltage for LED backlight	$V_L$	8.1	8.6	9	V	Note 1
Current for LED backlight	$I_L$	198	200	202	mA	
LED life time	-	15000		-	Hr	Note 2

Note 1: The LED Supply Voltage is defined by the number of LED at  $T_a=25^{\circ}C$  and  $I_L = 200mA$ .

Note 2: The “LED life time” is defined as the module brightness decrease to 50% original brightness at  $T_a=25^{\circ}C$  and  $I_L = 200mA$ . The LED lifetime could be decreased if operating  $I_L$  is larger than 200mA.



### 3.2. Typical Operation Conditions

( Note 1 )

Item	Symbol	Values			Unit	Remark
		Min.	Typ.	Max.		
Power voltage	VDD	2.3	2.5	2.7	V	Note 2
	AVDD	8.0	8.2	8.4	V	
	V <sub>GH</sub>	21.7	22	22.3	V	
	V <sub>GL</sub>	-7.3	-7	-6.7	V	
Input signal voltage	VCOM	2.7	3.0	3.3	V	Note 4
Input logic high voltage	V <sub>IH</sub>	0.8 VDD	/	3.6	V	Note 3
Input logic low voltage	V <sub>IL</sub>	0	/	0.2 DV <sub>DD</sub>	V	

- Note 1: Be sure to apply VDD and V<sub>GL</sub> to the LCD first, and then apply V<sub>GH</sub>.
- Note 2: VDD setting should match the signals output voltage (refer to Note 3) of customer's system board.
- Note 4: Typical VCOM is only a reference value, it must be optimized according to each LCM. Be sure to use VR.

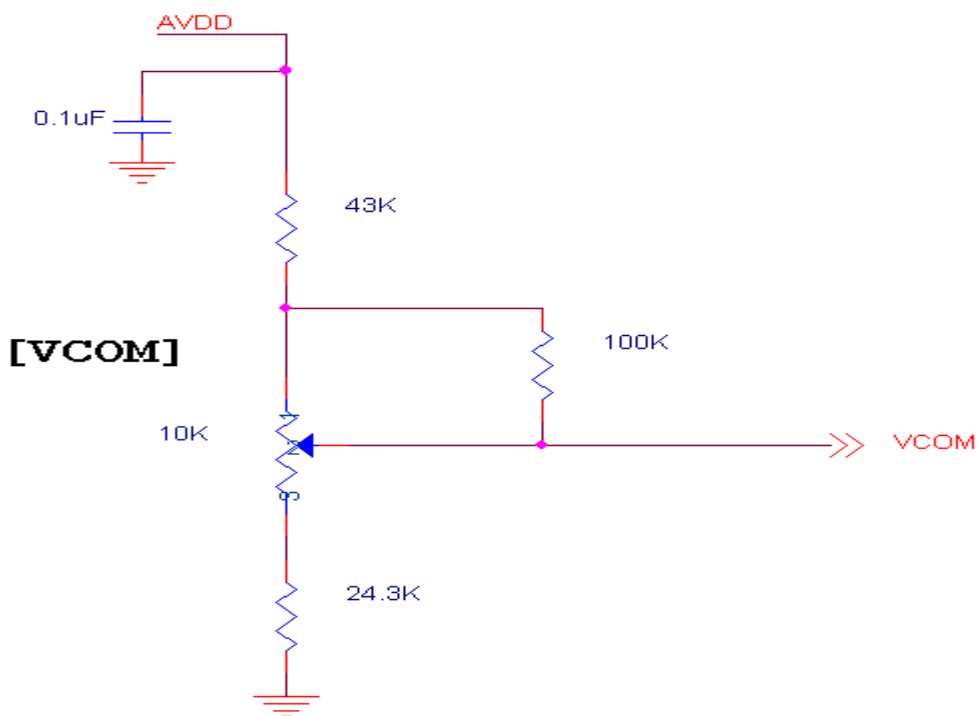

### 3.3. Power Sequence

a. Power on:

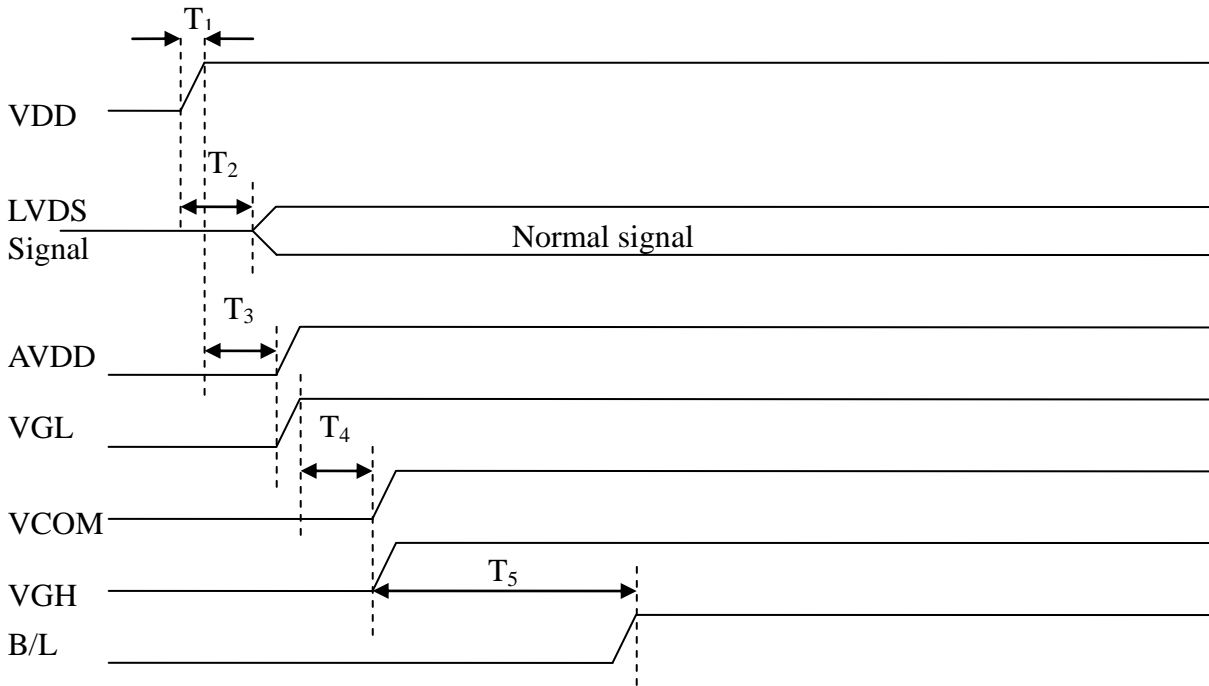

Symbol	Value			Unit
	Min.	Typ.	Max.	
<b>T1</b>	<b>0.5</b>	<b>2</b>	<b>10</b>	<b>ms</b>
<b>T2</b>	<b>0</b>	<b>5</b>	<b>50</b>	<b>ms</b>
<b>T3</b>	<b>0</b>	<b>5</b>	<b>50</b>	<b>ms</b>
<b>T4</b>	<b>0</b>	<b>6</b>	<b>100</b>	<b>ms</b>
<b>T5</b>	<b>120</b>	<b>130</b>	<b>200</b>	<b>ms</b>

**b. Power off:**

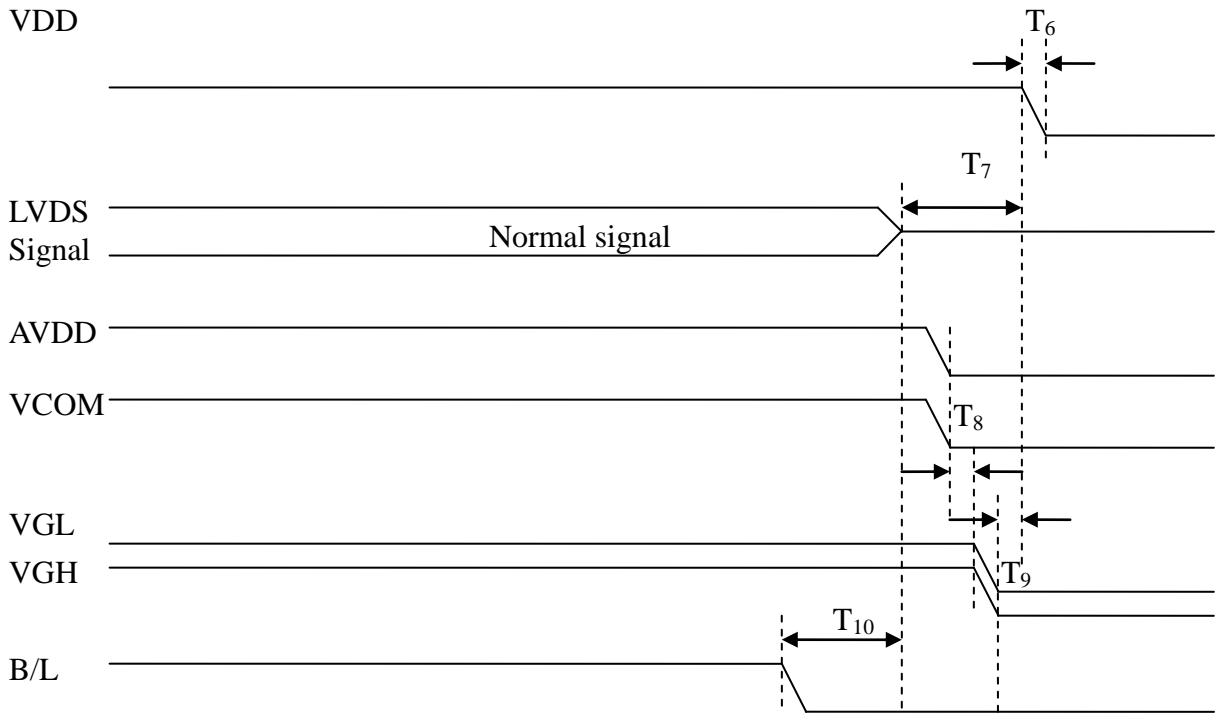

Symbol	Value			Unit
	Min.	Typ.	Max.	
<b>T6</b>	<b>0.5</b>	<b>2</b>	<b>10</b>	<b>ms</b>
<b>T7</b>	<b>0</b>	<b>7</b>	<b>50</b>	<b>ms</b>
<b>T8</b>	<b>0</b>	<b>5</b>	<b>10</b>	<b>ms</b>
<b>T9</b>	<b>0</b>	<b>1</b>	<b>10</b>	<b>ms</b>
<b>T10</b>	<b>0</b>	<b>2</b>	<b>100</b>	<b>ms</b>

**3.4. LVDS Signal Timing Characteristics**

**3.4.1. AC Electrical Characteristics**

Parameter	Symbol	Values			Unit	Remark
		Min.	Typ.	Max.		
LVDS Differential input high Threshold voltage	$R_{xVTH}$	-	-	+100	mV	$R_{xVCM}=1.2V$
LVDS Differential input low Threshold voltage	$R_{xVTL}$	-100	-	-	mV	
LVDS Differential input common mode voltage	$R_{xVCM}$	0.7	-	1.6	V	
LVDS Differential voltage	$ V_{ID} $	200	-	600	mV	

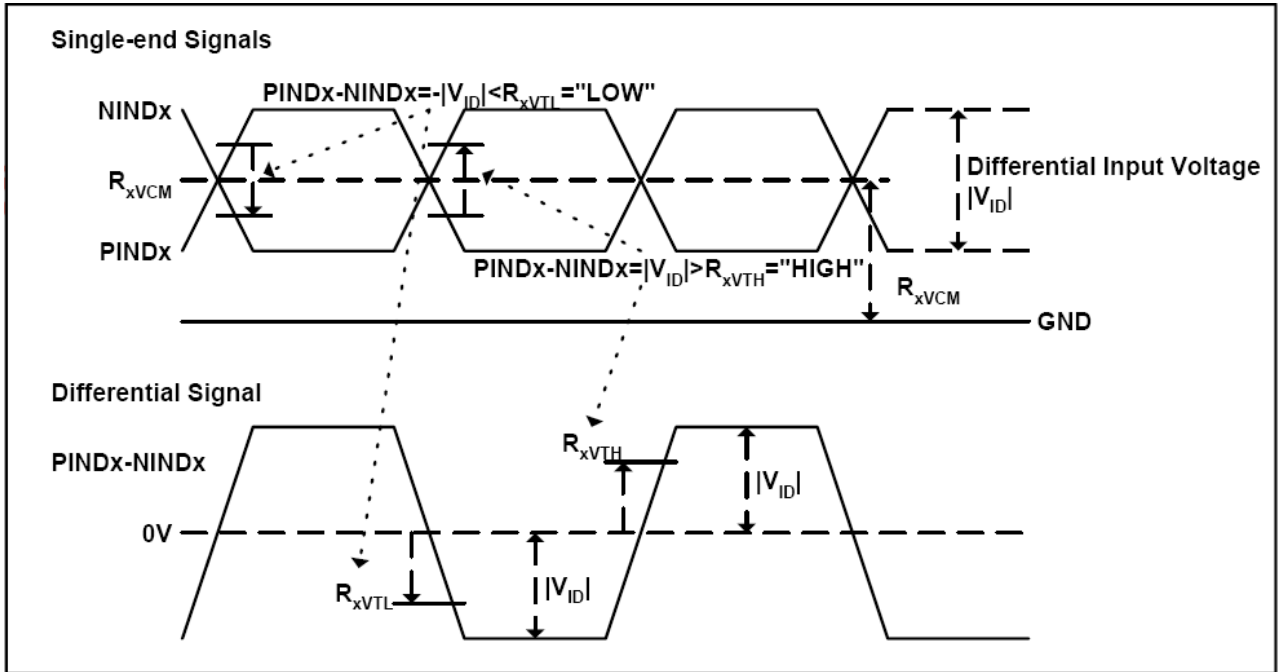

3.4.2. Timing Table

Item	Symbol	Values			Unit	Remark
		Min.	Typ.	Max.		
Clock Frequency	1/Tc	68.9	71.1	73.4	MHz	Frame rate =60Hz
Horizontal display area	tHD	1280			Tc	
HS period time	tH	1410	1440	1470	Tc	
HS Width +Back Porch +Front Porch	tHW+ tHBP +tHFP	130	160	190	Tc	
Vertical display area	tVD	800			tH	
VS period time	tV	815	823	833	tH	
VS Width +Back Porch +Front Porch	tVW+ tVBP +tVFP	15	23	33	tH	

Note: Frame rate is 60±5Hz, PCLK=Vtotal\*Htotal\*Frame Rate

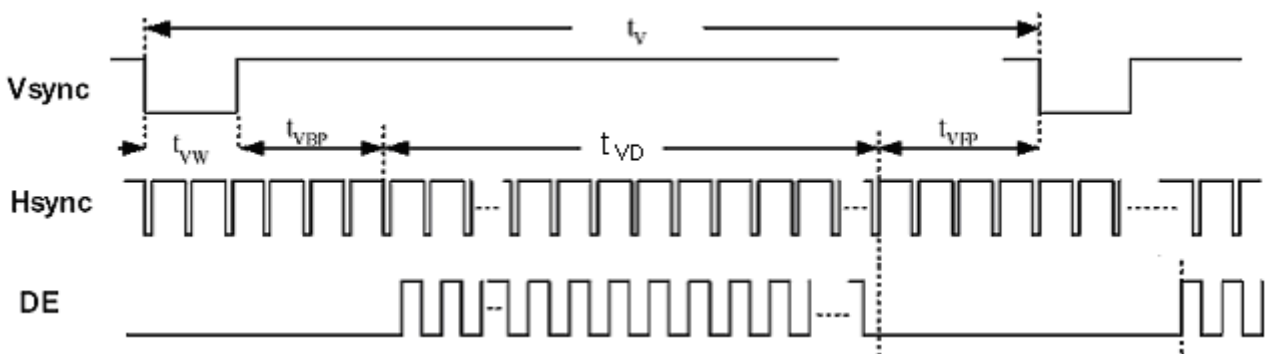

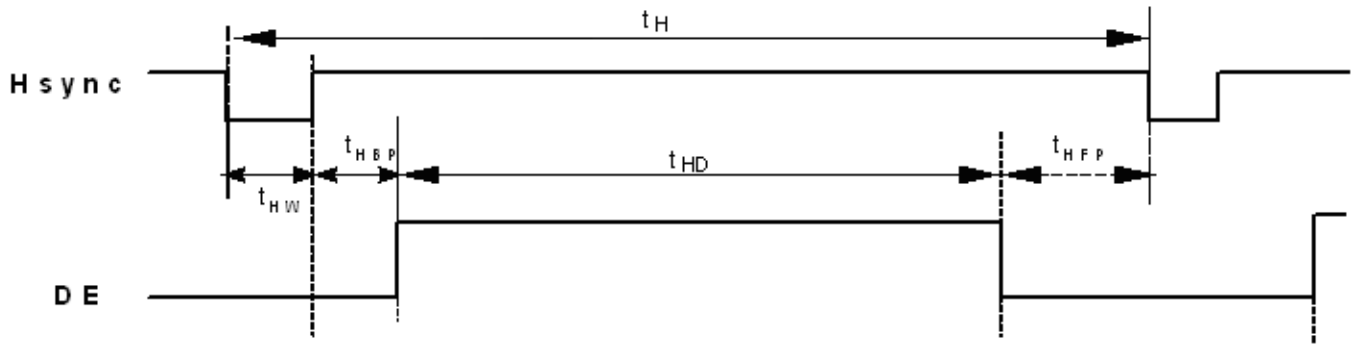

### 3.4.3. LVDS Data Input Format

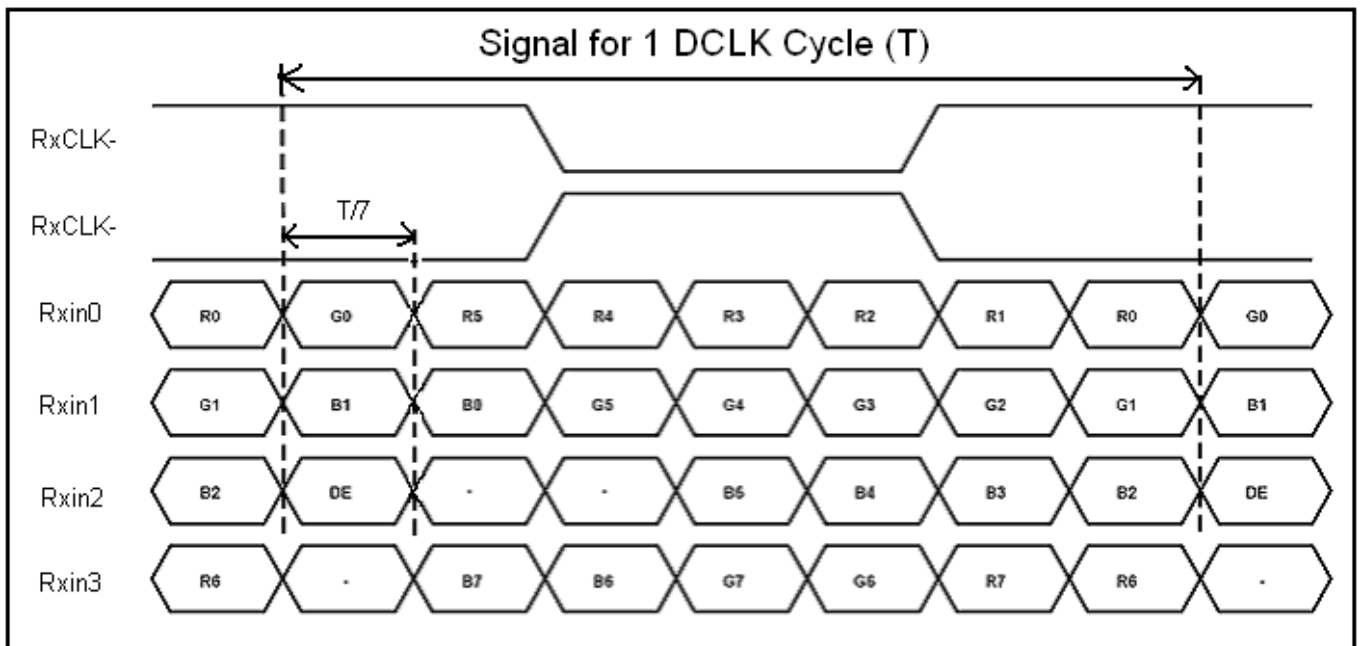

# 4. Optical Specifications

Item	Symbol	Condition	Values			Unit	Remark
			Min.	Typ.	Max.		
Viewing angle (CR≥ 10)	$\theta_L$	$\Phi=180^\circ$ (9 o'clock)	75	85	-	degree	Note 1
	$\theta_R$	$\Phi=0^\circ$ (3 o'clock)	75	85	-		
	$\theta_T$	$\Phi=90^\circ$ (12 o'clock)	75	85	-		
	$\theta_B$	$\Phi=270^\circ$ (6 o'clock)	75	85	-		
Response time	$T_{ON}$	Normal $\theta=\Phi=0^\circ$	-	10	20	msec	Note 3
	$T_{OFF}$		-	15	30	msec	Note 3
Contrast ratio	CR		600	800	-	-	Note 4
Color chromaticity	$W_X$		0.26	0.31	0.36	-	Note 2 Note 5 Note 6
	$W_Y$		0.28	0.33	0.38	-	
Luminance	L		280	350	-	cd/m <sup>2</sup>	Note 6
Luminance uniformity	$Y_U$		75	80	-	%	Note 7

**Test Conditions:**

1. VDD=2.5V, the ambient temperature is 25°C.
2. The test systems refer to Note 2.

Note 1: Definition of viewing angle range

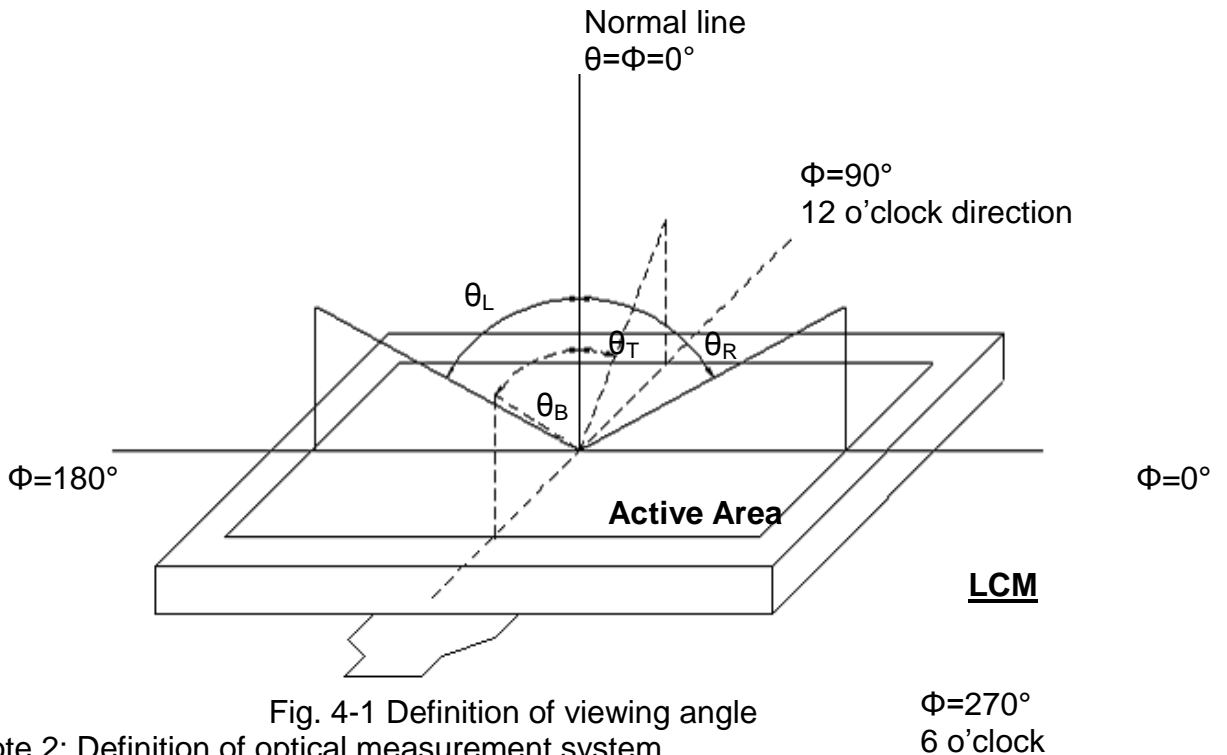

Fig. 4-1 Definition of viewing angle

Note 2: Definition of optical measurement system.

The optical characteristics should be measured in dark room. After 30 minutes operation, the optical properties are measured at the center point of the LCD screen. (Viewing angle is measured by ELDIM-EZ contrast/Height :1.2mm, Response time is measured by Photo detector TOPCON BM-7, other items are measured by BM-5A/ Field of view:  $1^\circ$  /Height: 500mm.)

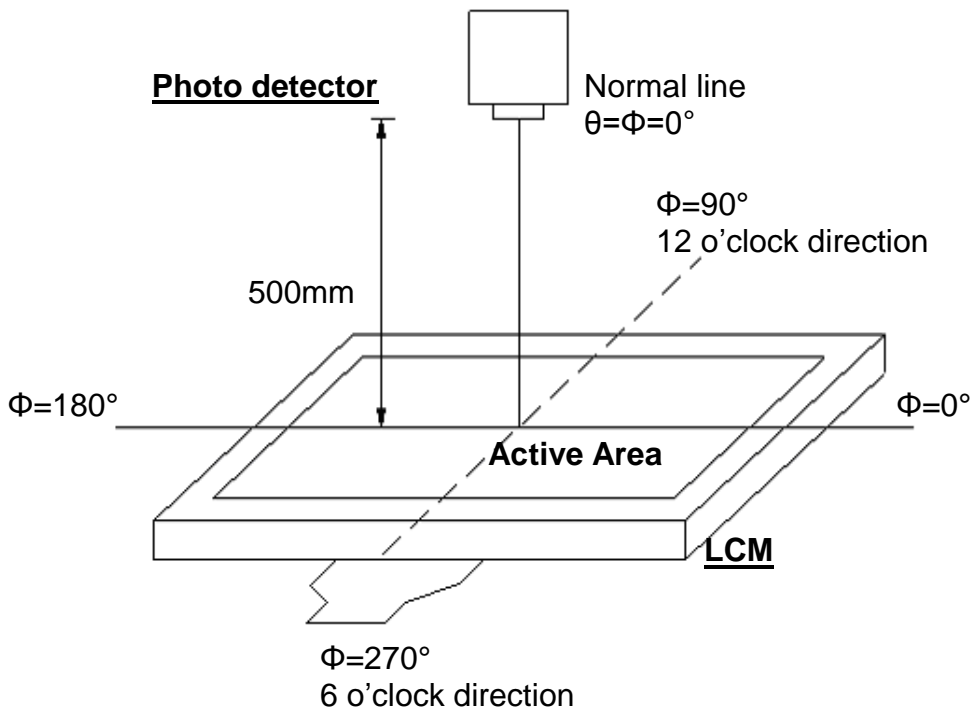

Fig. 4-2 Optical measurement system setup

Note 3: Definition of Response time

The response time is defined as the LCD optical switching time interval between “White” state and “Black” state. Rise time ( $T_{ON}$ ) is the time between photo detector output intensity changed from 90% to 10%. And fall time ( $T_{OFF}$ ) is the time between photo detector output intensity changed from 10% to 90%.

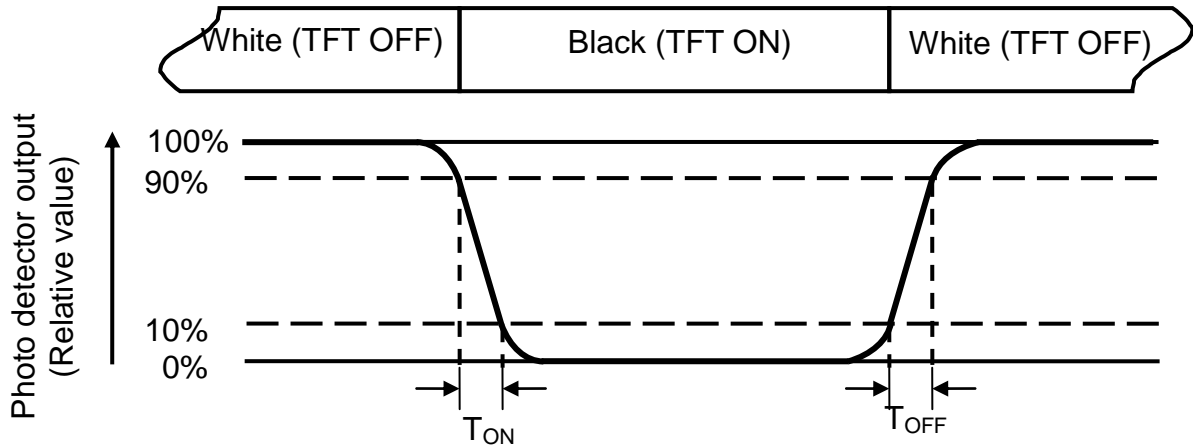

Fig. 4-3 Definition of response time

Note 4: Definition of contrast ratio

$$\text{Contrast ratio (CR)} = \frac{\text{Luminance measured when LCD on the "White" state}}{\text{Luminance measured when LCD on the "Black" state}}$$

Note 5: Definition of color chromaticity (CIE1931)

Color coordinates measured at center point of LCD.

Note 6: All input terminals LCD panel must be ground while measuring the center area of the panel. The LED driving condition is  $I_L=200\text{mA}$ .



Note 7: Definition of Luminance Uniformity

Active area is divided into 9 measuring areas (Refer to Fig. 4-4 ).Every measuring point is placed at the center of each measuring area.

$$Luminance\ Uniformity\ (Y_{ty}) = \frac{B_{min}}{B_{max}}$$

L-----Active area length      W----- Active area width

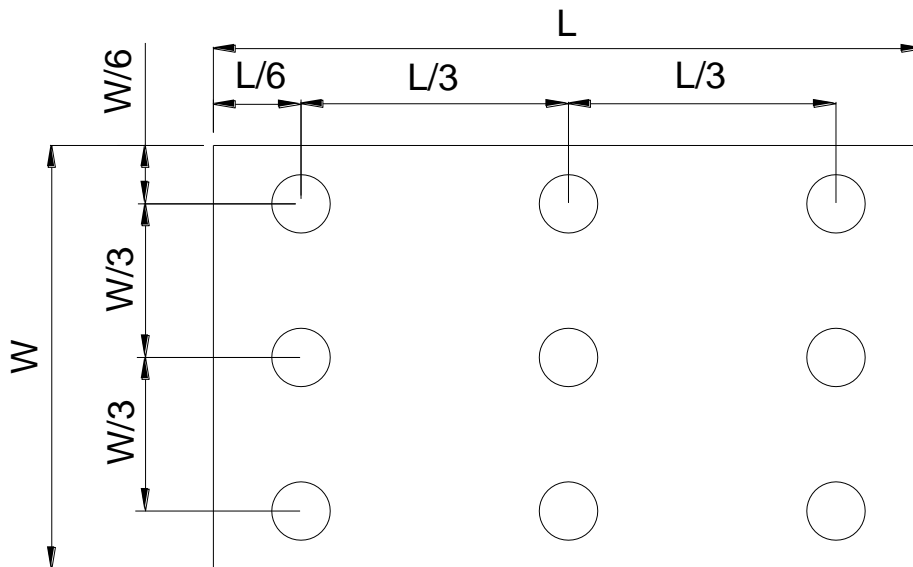

Fig. 4-4 Definition of measuring points

**B<sub>max</sub>**: The measured maximum luminance of all measurement position.  
**B<sub>min</sub>**: The measured minimum luminance of all measurement position.

## 5. Reliability Test Items

(Note3)

Item	Test Conditions	Remark
High Temperature Storage	Ta = 70°C                      120hrs	Note 1, Note 4
Low Temperature Storage	Ta = -20°C                      120hrs	Note 1, Note 4
High Temperature Operation	Ts = 60°C                      120hrs	Note 2, Note 4
Low Temperature Operation	Ta = -10°C                      120hrs	Note 1, Note 4
Operate at High Temperature and Humidity	+40°C, 90%RH                  120hrs	Note 4
Thermal Shock	-0°C/30 min ~ +50°C/30 min for a total 100 cycles, Start with cold temperature and end with high temperature.	Note 4
Vibration Test	Frequency: 10 ~55~10Hz;Sweep Mode: Log Sweep Sweep time: 1Oct/min;Acceleration: 0.5G; Test time:2hrs for each direction of X, Y, Z.	
Mechanical Shock	100G 6ms,±X, ±Y, ±Z 3 times for each direction	
Package Vibration Test	Random Vibration : ISTA-3A 1Hz~200Hz,Grms=0.53 Half hours for direction of Z.	
Package Drop Test	Height:60 cm 1 corner, 3 edges, 6 surfaces	
Electro Static Discharge	± 2KV, Human Body Mode, 100pF/1500Ω	

Note 1: Ta is the ambient temperature of samples.

Note 2: Ts is the temperature of panel's surface.

Note 3: In the standard condition, there shall be no practical problem that may affect the display function. After the reliability test, the product only guarantees operation, but don't guarantee all of the cosmetic specification.

Note 4: Before cosmetic and function test, the product must have enough recovery time, at least 2 hours at room temperature.

## 6. General Precautions

### 6.1. Safety

Liquid crystal is poisonous. Do not put it in your mouth. If liquid crystal touches your skin or clothes, wash it off immediately by using soap and water.

### 6.2. Handling

1. The LCD panel is plate glass. Do not subject the panel to mechanical shock or to excessive force on its surface.
2. The polarizer attached to the display is easily damaged. Please handle it carefully to avoid scratch or other damages.
3. To avoid contamination on the display surface, do not touch the module surface with bare hands.
4. Keep a space so that the LCD panels do not touch other components.
5. Put cover board such as acrylic board on the surface of LCD panel to protect panel from damages.
6. Transparent electrodes may be disconnected if you use the LCD panel under environmental conditions where the condensation of dew occurs.
7. Do not leave module in direct sunlight to avoid malfunction of the ICs.

### 6.3. Static Electricity

1. Be sure to ground module before turning on power or operating module.
2. Do not apply voltage which exceeds the absolute maximum rating value.

### 6.4. Storage

1. Store the module in a dark room where must keep at  $25\pm 10^{\circ}\text{C}$  and 65%RH or less.
2. Do not store the module in surroundings containing organic solvent or corrosive gas.
3. Store the module in an anti-electrostatic container or bag.

### 6.5. Cleaning

1. Do not wipe the polarizer with dry cloth. It might cause scratch.
2. Only use a soft cloth with IPA to wipe the polarizer, other chemicals might permanent damage to the polarizer.



## 8. Package Drawing

### 8.1. Packaging Material Table

No.	Item	Model (Material)	Dimensions(mm)	Unit Weight (kg)	Quantity	Remark
1	LCM Module	EJ101IA-01G	229.46 x149.1x2.5	0.183	34	
2	EPE spacer	EPE	314 x 225 x 3.2	0.0056	17	
3	Dust-Proof Bag	PE	580 x 380	0.062	1	
4	Tray	PET	361 x 286 x 19.2	0.14	18	
5	Cushion	EPE	515x 351 x 90	0.205	2	
6	Drier	SILICA GEL	100 x 75	0.032	2	
7	Carton	Corrugated Paper	530 x 367 x 260	0.95	1	
8	Total weight	10.32 Kg ± 5%				

### 8.2. Packaging Quantity

(1) LCM quantity per PET-Tray:	2pcs
(2) Total LCM quantity in Carton:	17 layer x 2pcs/PET-Tray = 34pcs

### 8.3. Packaging Drawing

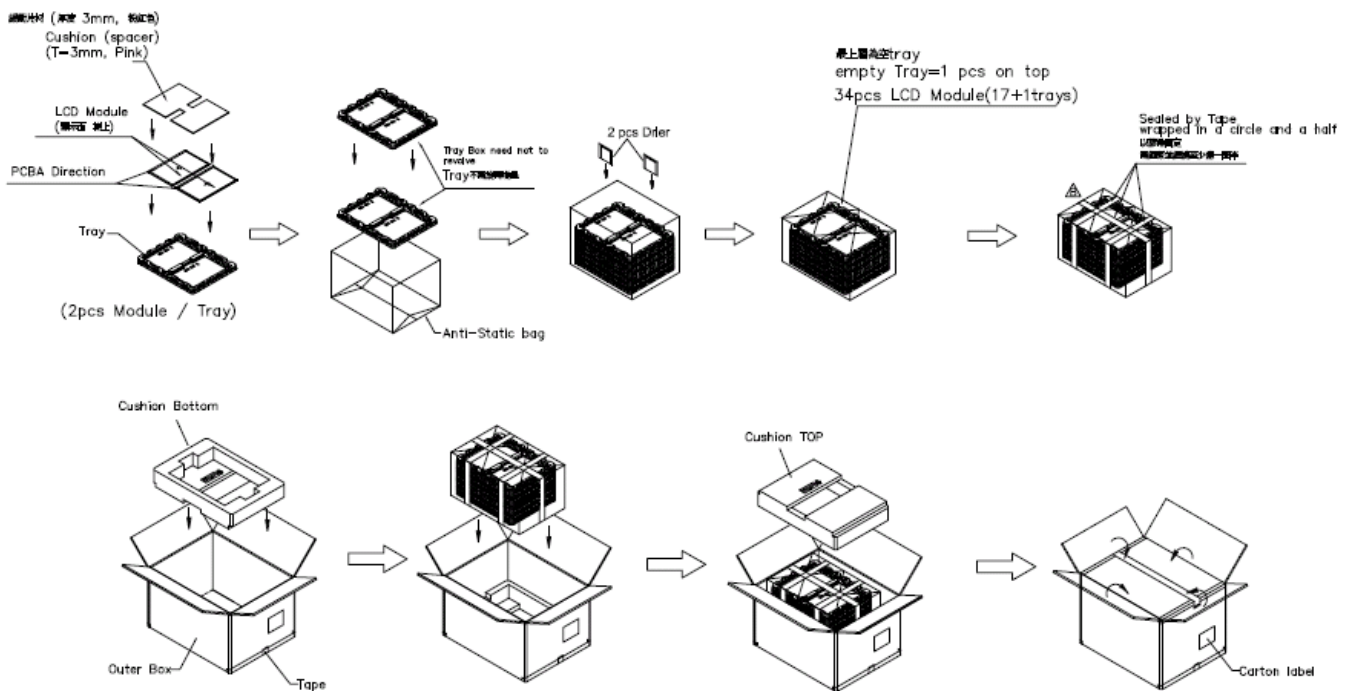

- (1) Box Dimensions : 530(L)\*367(W)\*260(H)
- (2) 34 Modules/Carton

**Air Transportation**  
**Sea / Land Transportation**  
**(40ft /40ft HQ Container)**

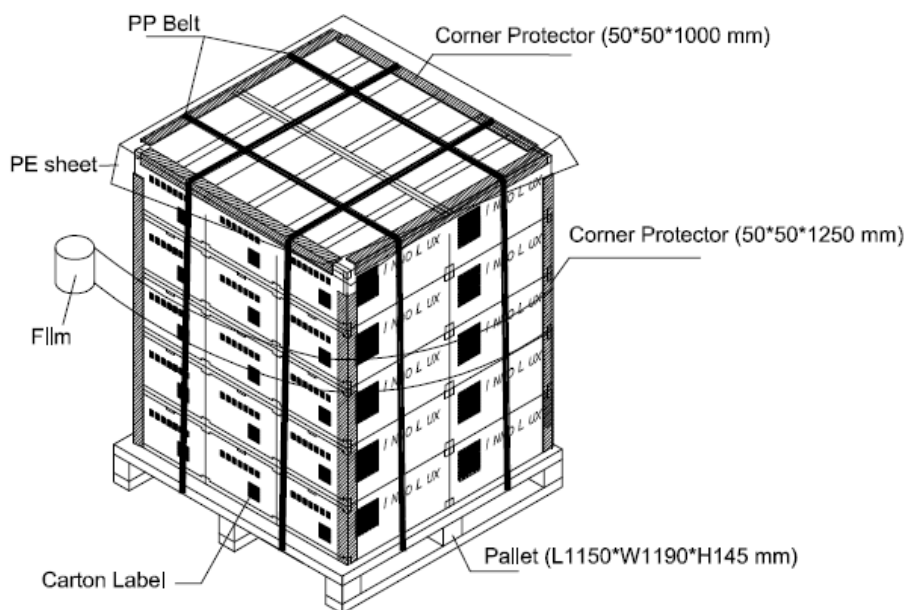

**30 cartons / pallet**