

eKF5280

**USB2.0 Flash
Controller**

**Product
Specification**

DOC. VERSION 1.0

ELAN MICROELECTRONICS CORP.

February 2006



Trademark Acknowledgments:

IBM is a registered trademark and PS/2 is a trademark of IBM.

Windows is a trademark of Microsoft Corporation

ELAN and ELAN logo  are trademarks of ELAN Microelectronics Corporation

Copyright © 2006 by **ELAN Microelectronics Corporation**

All Rights Reserved

Printed in Taiwan

The contents of this specification are subject to change without further notice. ELAN Microelectronics assumes no responsibility concerning the accuracy, adequacy, or completeness of this specification. ELAN Microelectronics makes no commitment to update, or to keep current the information and material contained in this specification. Such information and material may change to conform to each confirmed order.

In no event shall ELAN Microelectronics be made responsible for any claims attributed to errors, omissions, or other inaccuracies in the information or material contained in this specification. ELAN Microelectronics shall not be liable for direct, indirect, special incidental, or consequential damages arising from the use of such information or material.

The software (if any) described in this specification is furnished under a license or nondisclosure agreement, and may be used or copied only in accordance with the terms of such agreement.

ELAN Microelectronics products are not intended for use in life support appliances, devices, or systems. Use of ELAN Microelectronics product in such applications is not supported and is prohibited.

NO PART OF THIS SPECIFICATION MAY BE REPRODUCED OR TRANSMITTED IN ANY FORM OR BY ANY MEANS WITHOUT THE EXPRESSED WRITTEN PERMISSION OF ELAN MICROELECTRONICS.



ELAN MICROELECTRONICS CORPORATION

Headquarters:

No. 12, Innovation Road 1

Hsinchu Science Park

Hsinchu, Taiwan 30077

Tel: +886 3 563-9977

Fax: +886 3 563-9966

<http://www.emc.com.tw>

Hong Kong:

Elan (HK) Microelectronics Corporation, Ltd.

Flat A, 19/F., World Tech Centre

95 How Ming Street, Kwun Tong

Kowloon, HONG KONG

Tel: +852 2723-3376

Fax: +852 2723-7780

elanhk@emc.com.hk

USA:

Elan Information Technology Group (USA)

1821 Saratoga Ave., Suite 250

Saratoga, CA 95070

USA

Tel: +1 408 366-8225

Fax: +1 408 366-8220

Europe:

Elan Microelectronics Corp. (Europe)

Siewerdstrasse 105

8050 Zurich, SWITZERLAND

Tel: +41 43 299-4060

Fax: +41 43 299-4079

<http://www.elan-europe.com>

Shenzhen:

Elan Microelectronics Shenzhen, Ltd.

SSMEC Bldg., 3F, Gaoxin S. Ave.

Shenzhen Hi-Tech Industrial Park

Shenzhen, Guangdong, CHINA

Tel: +86 755 2601-0565

Fax: +86 755 2601-0500

Shanghai:

Elan Microelectronics Shanghai, Ltd.

23/Bldg. #115 Lane 572, Bibo Road

Zhangjiang Hi-Tech Park

Shanghai, CHINA

Tel: +86 21 5080-3866

Fax: +86 21 5080-4600

Contents

1	Description.....	1
2	Features	1
3	Unique Function Descriptions.....	2
4	Applications	3
5	Pin Configuration and Assignment.....	3
6	Pin Descriptions	4
7	Function Block Diagram	5
8	DC Electrical Characteristic.....	6
8.1	MISC	6
8.2	I/O8.....	6
8.3	I/O12.....	6
8.4	I/O10.....	7
8.5	I/O-U5.....	7
8.6	I/O-U50	7
8.7	I-L	7
8.8	I-S.....	7
9	Absolute Maximum Ratings.....	8
10	Flash Compatibility Support with Samsung, Hynix, ST and Toshiba	8
11	Application Circuit.....	9



Specification Revision History

Doc. Version	Revision Description	Date
1.0	Initial Released Version	2006/02/23

1 Description

The eKF5280 Flash Controller provides a high-performance interface for bridging USB2.0 and NAND Flash compliance device, thus allowing the device to implement flash memory storage function through USB interface. The eKF5280 contains an 8-bit RISC processor which could significantly reduce efforts of firmware development. Furthermore, the Controller is embedded with a Phase Lock Loop (PLL). The PLL provides all the internal clocks needed by the Controller. However, the required 12 MHz external clock has to be provided externally.

The eKF5280 is capable of controlling up to 8 pieces of NAND Flash memory with flash capacity ranging from 16M bytes to 512M bytes. The Controller can be available in a number of feature combinations to accommodate customer's requirements. It has been optimized to support Toshiba, Samsung and Hynix/ST SLC (single level cell) flash memory designs. The controller has a write-protect feature for preventing accidental writing to flash.

2 Features

- USB Specification v2.0 Compliant
- USB Mass Storage Class v1.0 Compliant
- Supports 480 MBits/s Full High Speed Serial Data Transmission
- Support USB Mass Storage Class Bulk-Only Spec
- USB bus-powered capability
- Build in PLL used to generate clock for USB and MCU
- Oscillator: 12MHz
- Supports a total of 4 Endpoints:
 - Endpoint 0 is the default control endpoint
 - Endpoint 1 is the Bulk-in endpoint
 - Endpoint 2 is the Bulk-out endpoint
 - Endpoint 3 is the Interrupt-in endpoint
- Support ping-pong buffer(two 2120x8 bits) for data transfer to/from NAND Flash
- Support up to 8 pieces of NAND Flash memory
- 1 LED sink pins with internal serial resistor
- Support wear leveling
- Support write-protected ability
- Higher reliability: ECC on the fly
- Support untested/downgrade NAND Flash
- Embedded 5-3.3 regulator, and 3.3-2.5 regulator
- One 8-bit general purpose timer



- Supports saving power (SLEEP) mode
- 8K x 13 on chip ROM (Program)
- 8-Level stack for subroutine nesting
- MCU runs at 30MHz
- Performance: Read (11M Bytes/s), Write (8M Bytes/s) Max
- Supported OS: Win XP, Win 2000, Win ME, and MAC OS 9.0 & higher.
Win 98 driver available upon request.
- Package : LQFP48 (7mm * 7mm)

3 Unique Function Descriptions

The following special features may be implemented to assist system manufactures in making high quality, low cost USB storage systems.

- The eKF5280 supports down-graded/untested NAND Flash. During testing of the target NAND flash, if a flawed block is found, the controller will mark and isolate this defective block. Consequently, the isolated block is excluded from operation thereafter. The test software for this function is included in the supporting programs provided with the controller.
- To reduce cost and increase performance & reliability, the eKF5280 is equipped with a built-in SRAM Look-Up-Table to support logical-to-physical address translation.
- The eKF5280 is also embedded with a built-in ECC function. The real time ECC correction maintains the data integrity while preserving the high data transfer rate at the same time.
- A wear-level algorithm is implemented in the eKF5280 firmware to prevent oxide degradation and subsequent failure from numerous repetitions of flash erase/programming operation on the same block at high voltage. This algorithm updates the data of a block into different new physical links to alleviate repetitive cycling on the same block.
- The eKF5280 is also equipped with a built-in 5 volt to 3.3 volt regulator. So there is no need for an external regulator. Hence your BOM cost is reduced.
- No additional driver is required for eKF5280 operation. It works readily with Win XP, Win 2000, Win ME, and MAC OS 9.0 & higher (Win 98 is also supported after installing a separate driver).

4 Applications

- NAND Flash Controller
- Smart Media Controller

5 Pin Configuration and Assignment

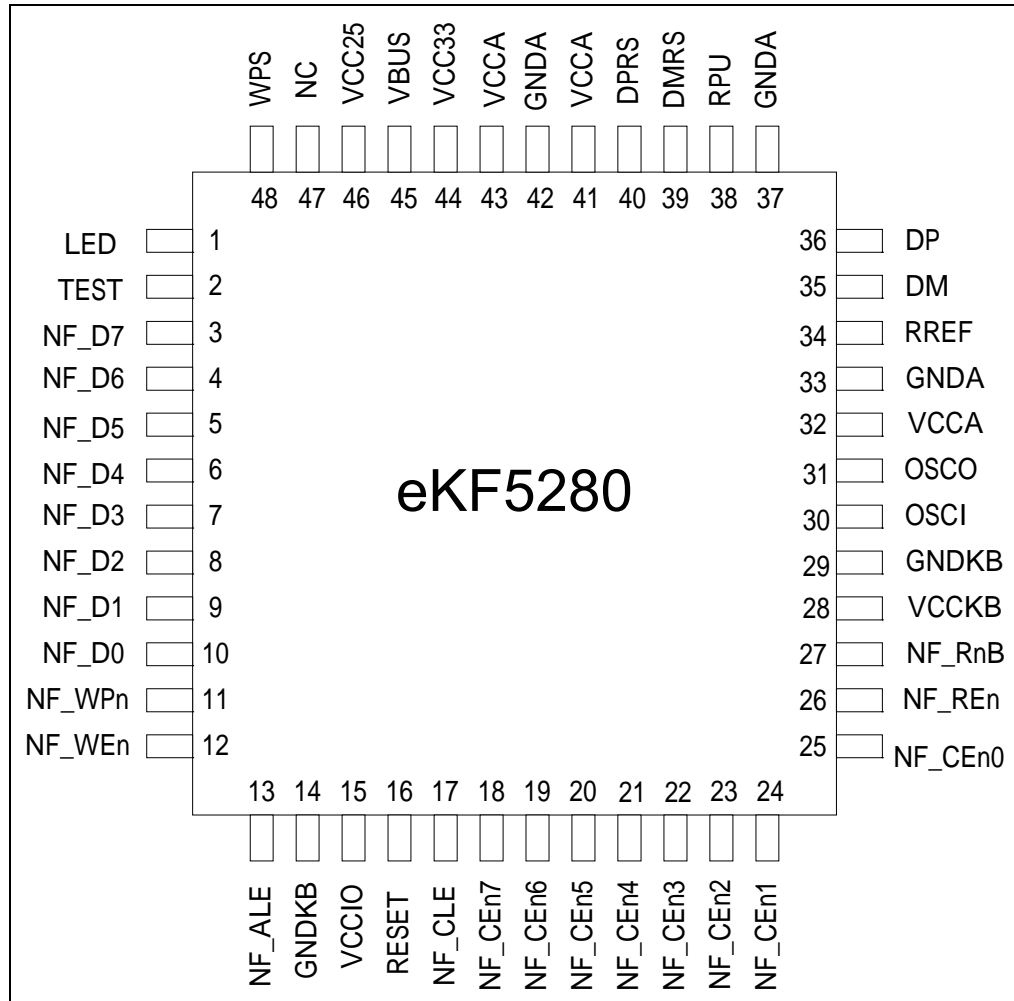

Figure 4-1 eKF5280 Pin Configuration and Assignment



6 Pin Descriptions

Pin Name	I/O Type	Description	Remarks
Power and Ground Pin			
VBUS	-	USB bus power	5.0V
VCCA	-	Internal regulator output for analog supply voltage	3.3V
GND A	-	Analog ground	-
VCCKB	-	Internal regulator output for transceiver digital core	2.5V
GNDKB	-	Digital ground	-
VCCIO	-	Internal regulator output for I/O port	3.3V
VCC25	-	Internal regulator output for digital core	2.5V
VCC33	-	Internal regulator output	3.3V
USB Analog Signal			
DP	I/O	USB plus data line interface	-
DM	I/O	USB minus data line interface	-
DPRS	I	USB1.1 data in data positive pin terminal, connected to external resistor(39Ω±5%)	-
DMRS	I	USB1.1 data in data negative pin terminal, connected to external resistor (39Ω±5%)	-
RPU	I	Connect external resistor (1.5KΩ±5%) to AVCC	-
RREF	I	Connect external reference resistor (12.1 KΩ±1%) to analog ground(GNDA)	-
NAND Flash Interface Signal			
NF_CEn0~7	I/O	Chip enable for NAND Flash	I/O8
NF_RnB	I	NAND Flash Ready or Busy	I/O-U5
NF_REn	O	Read enable for NAND Flash	I/O12
NF_CLE	O	Command latch enable for NAND Flash	I/O12
NF_ALE	O	Address latch enable for NAND Flash	I/O12
NF_WEn	O	Write enable for NAND Flash	I/O12
NF_WPn	O	Write protect for NAND Flash	I/O8
NF_D0~7	I/O	Data input/output for NAND Flash	I/O12
Miscellaneous			
LED	O	LED sink pin	I/O10
OSCI	I	Crystal input terminal or external clock input	-
OSCO	O	Output terminal for crystal oscillator or external clock	-
WPS	I	Write protect switch	I/O-U50
TEST	I	TEST Pin	I/O-L
RESET	I	Reset Pin (2 nd reset source in case of POR failure)	I-S

7 Function Block Diagram

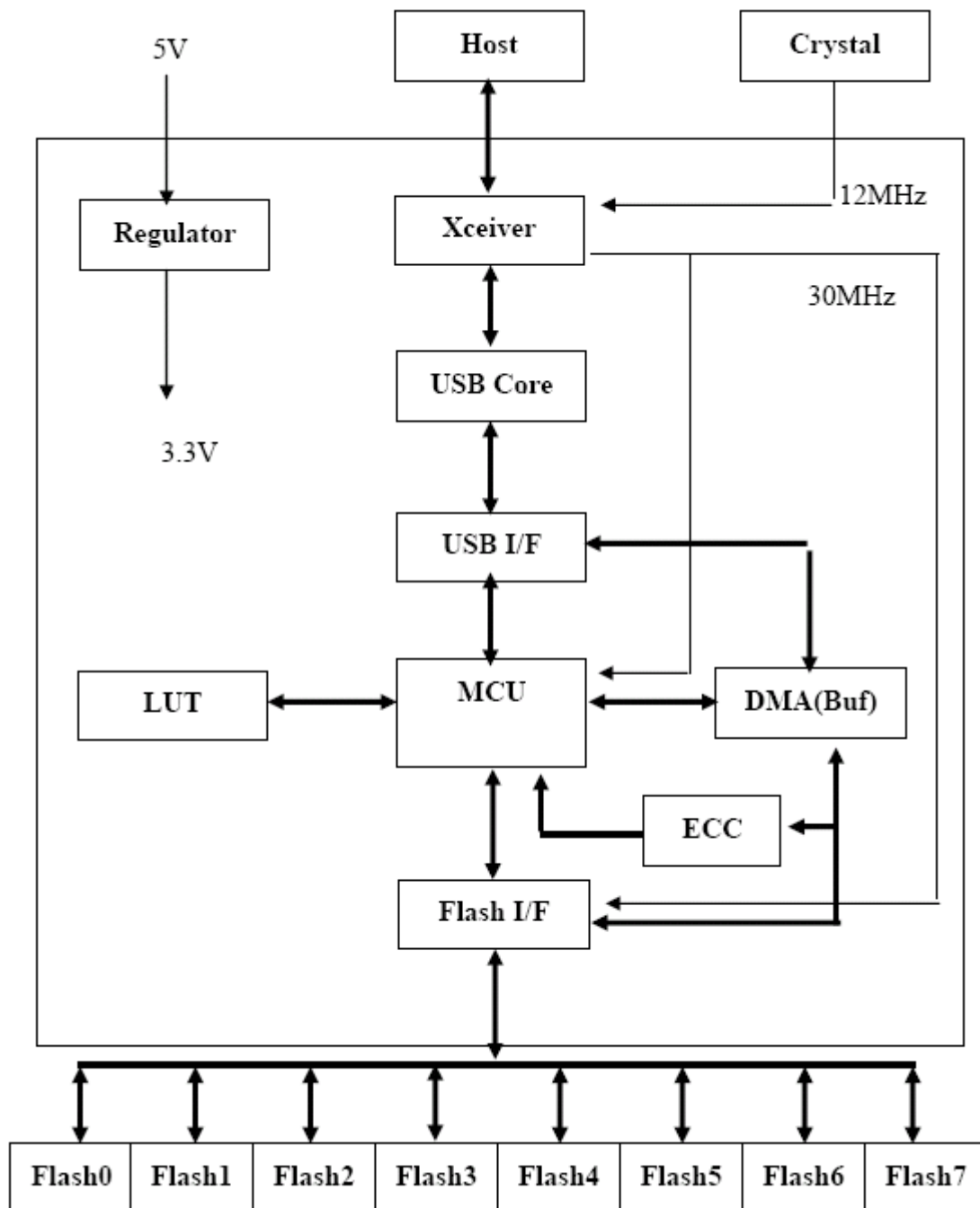

Figure 6-1 eKF5280 Functional Block Diagram

8 DC Electrical Characteristic

8.1 MISC

■ (Ta=0°C~70°C, VD=3.3V, VSS=0V)

Symbol	Parameter	Condition	Min	Typ	Max	Unit
VBUS	USB bus power		4.4	5.0	5.25	V
VCC33	3.3-V Regulator output		3.0	3.3	3.6	V
VCC25	2.5-V Regulator output		2.25	2.5	2.75	V
ICC33	Operating supply current for 3.3-V Regulator				150	mA
ICC25	Operating supply current for 2.5-V Regulator				100	mA
IIL	Input Leakage Current	VIN = VD, VSS			±1	μA
VIHX	Clock Input High Voltage	OSCI	2.5			V
VILX	Clock Input Low Voltage	OSCI			1.0	V
ISB	Power down current	All input and I/O pin at VD, WDT enabled			150	μA
ICC	Operating supply current				110	mA

8.2 I/O8

Symbol	Parameter	Condition	Min	Typ	Max	Unit
VIH	Input High Voltage		2.0			V
VIL	Input Low Voltage				0.8	V
VOH	Output High Voltage	IOH = -8.0mA	2.4			V
VOL	Output Low Voltage	IOL = 8.0mA			0.4	V

8.3 I/O12

Symbol	Parameter	Condition	Min	Typ	Max	Unit
VIH	Input High Voltage		2.0			V
VIL	Input Low Voltage				0.8	V
VOH	Output High Voltage	IOH = -12.0mA	2.4			V
VOL	Output Low Voltage	IOL = 12.0mA			0.4	V

8.4 I/O10

Symbol	Parameter	Condition	Min	Typ	Max	Unit
VIH	Input High Voltage		2.0			V
VIL	Input Low Voltage				0.8	V
VOH	Output High Voltage	IOH = -8.0mA	2.4			V
VOL	Output Low Voltage	IOL = 10.0mA	-10%	1.3	10%	V

8.5 I/O-U5

Symbol	Parameter	Condition	Min	Typ	Max	Unit
VIH	Input High Voltage		2.0			V
VIL	Input Low Voltage				0.8	V
VOH	Output High Voltage	IOH = -8.0mA	2.4			V
VOL	Output Low Voltage	IOL = 8.0mA			0.4	V
Ru	Pull-high resistor(For NF_RnB Pin)		-20%	5	+20%	KΩ

8.6 I/O-U50

Symbol	Parameter	Condition	Min	Typ	Max	Unit
VIH	Input High Voltage		2.0			V
VIL	Input Low Voltage				0.8	V
VOH	Output High Voltage	IOH = -8.0mA	2.4			V
VOL	Output Low Voltage	IOL = 8.0mA			0.4	V
Ru	Pull-high resistor(For WPS Pin)		-20%	50	+20%	KΩ

8.7 I-L

Symbol	Parameter	Condition	Min	Typ	Max	Unit
Rd	Pull-low resistor		-20%	10	+20%	KΩ

8.8 I-S

Symbol	Parameter	Min	Typ	Max	Unit	Output
VIH	Schmitt trigger Input High Voltage		2.0		V	0V
VIL	Schmitt trigger Input Low Voltage		0.7		V	2.5V

9 Absolute Maximum Ratings

Operating temperature:	0 ° C to 70 ° C
Storage temperature:	-65 ° C to 150 ° C
Input voltage:	-0.5V to +6.0V
Output voltage:	-0.5V to +6.0V

10 Flash Compatibility Support with Samsung, Hynix, ST and Toshiba

		Part number
Samsung	16MB	K9F2808U0C
	32MB	K9F5608U0B
		K9F5608U0C
	64MB	K9F1208U0M
		K9F1208U0A(B,C)
	128MB	K9F1G08U0M
		K9K1G08U0M
		K9F1G08U0A
		K9K1G08U0A
	256MB	K9T1G08U0M
		K9K2G08U0A
	512MB	K9F2G08U0M
		K9F4G08U0M
		K9W4G08U1M
Hynix	32MB	K9K4G08U0M
	64MB	HY27US08561M
		HY27US08121M
	128MB	HY27UA081G1M
		HY27UF081G2M
256MB	HY27UB082G4M	
	HY27UG082G2M	
512MB	HY27UH084G2M	
ST	64MB	NAND512W3A
	128MB	NAND01GW3A
		NAND01GW3B
Toshiba	128MB	TC58NVG0S3AFT05
	256MB	TH58NVG1S3AFT(00/05)
		TC58NVG1S3BFT00
512MB	TH58NVG2S3BFT00	

11 Application Circuit

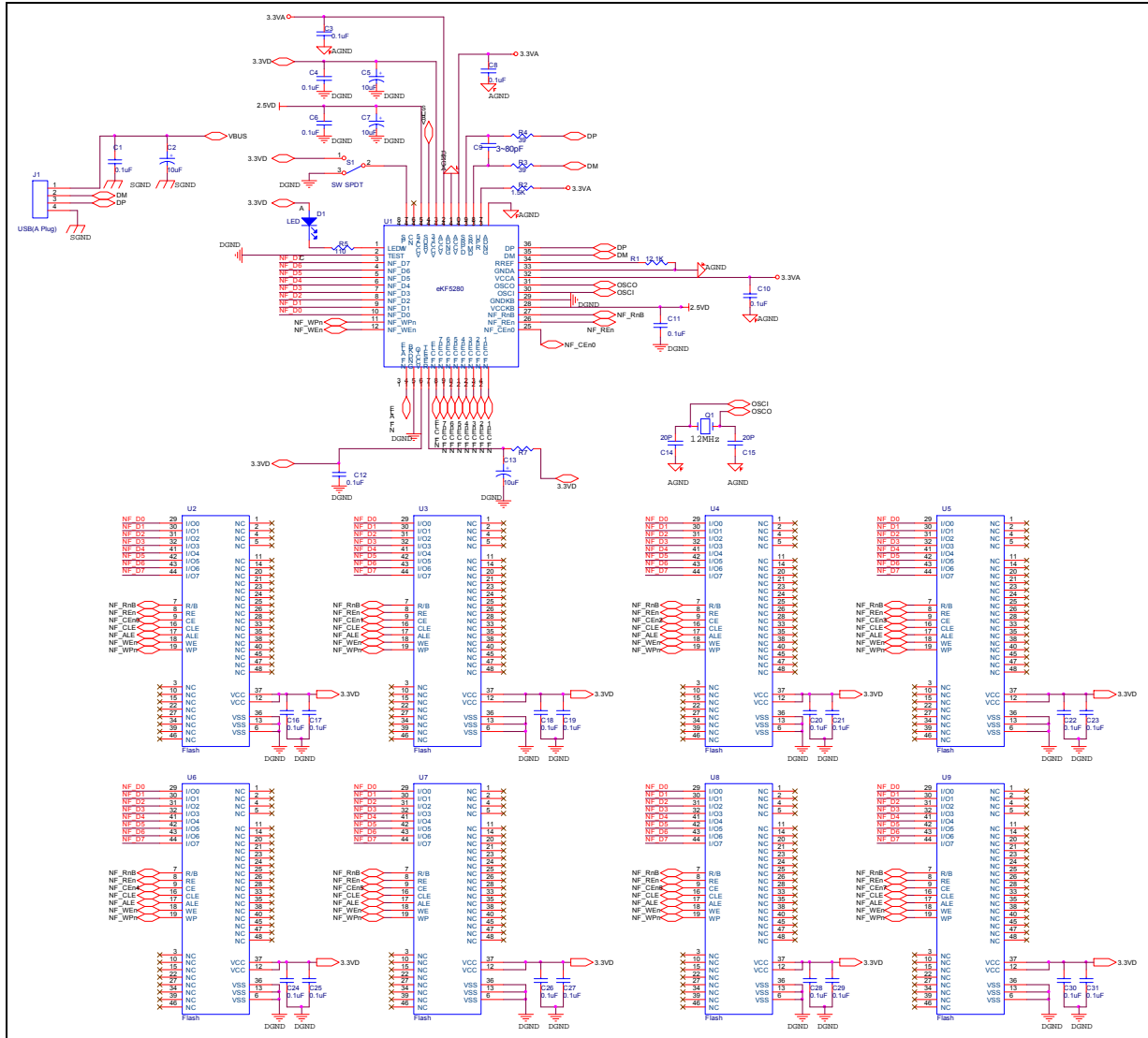

Figure 11-1 eKF5280 Application Circuit

