

EL 50 Amplifier for push-pull output stages

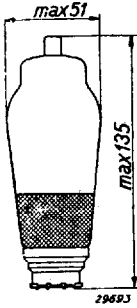

Fig. 1
Dimensions in mm.

The EL 50 is a pentode with a maximum anode dissipation of 18 W, having been designed especially for balanced output stages. Two of these valves in Class A/B at a maximum anode voltage of 800 V will provide an output of 84 W and this high anode voltage can be employed without the necessity for any special precautions in view of the fact that the anode connection is situated at the top of the bulb.

The form of the dynamic characteristic, moreover, is such as to render the valve relatively insensitive to electrical discrepancies between the two valves used in the stage. Like the 4654, the EL 50 can also be employed on a supply voltage of 425 V ($V_a = 400$ V, $V_{g2} = 425$ V), in which case the maximum output power of the two valves, on a fixed grid bias, is 50 W.

The ratings and operating data for this valve are given below.

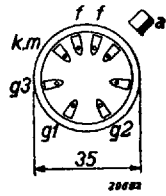
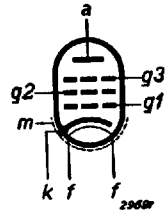
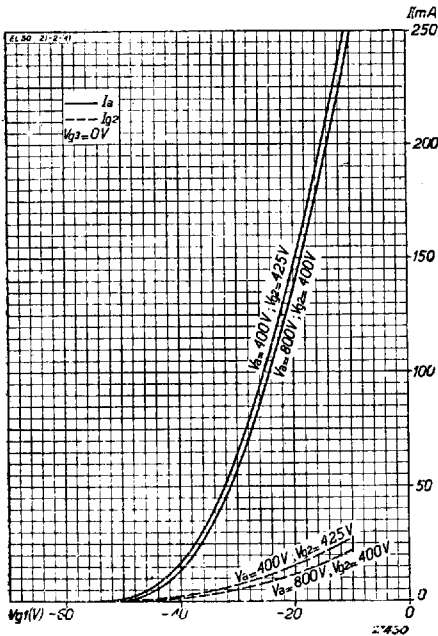

Fig. 2
Arrangement of electrodes and contacts.



HEATER RATINGS

Heater feed: indirect, A.C. parallel feed.
 Heater voltage $V_f = 6.3$ V
 Heater current $I_f = 1.35$ A

CAPACITANCES

Anode-control grid capacitance
 $C_{ag1} < 0.8$ pF

Fig. 3
Anode and screen voltage as a function of grid bias at $V_a = 400$ V, $V_{g2} = 425$ V and $V_a = 800$ V, $V_{g2} = 400$ V.

STATIC RATINGS

Anode voltage	$V_a = 400 \text{ V}$	800 V
Screen grid voltage	$V_{g2} = 425 \text{ V}$	400 V
Suppressor grid voltage	$V_{g3} = 0 \text{ V}$	0 V
Anode current	$I_a = 45 \text{ mA}$	22.5 mA
Screen grid current	$I_{g2} = 5.5 \text{ mA}$	2.5 mA
Grid bias	$V_{g1} = -33 \text{ V}$	-37 V
Mutual conductance	$S = 6 \text{ mA/V}$	4 mA/V
Internal resistance	$R_i = 30,000 \text{ Ohms}$	50,000 Ohms

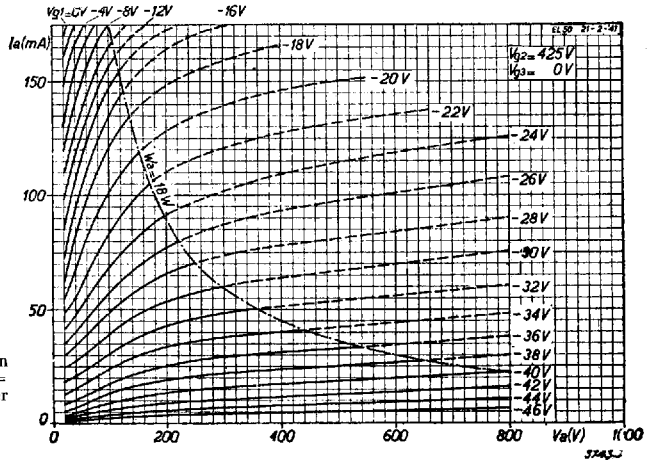

Fig. 4
Anode current as a function of anode voltage at $V_{g2} = 425 \text{ V}$, with V_{g1} as parameter (400 V operation).

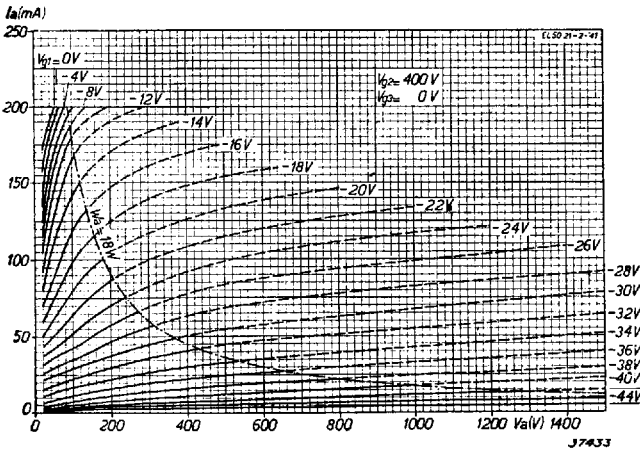

Fig. 5
Anode current as a function of anode voltage at $V_{g2} = 400 \text{ V}$, with V_{g1} as parameter (800 V operation).

DYNAMIC DATA for two EL 50 valves in class AB adjustment with automatic negative grid bias

Anode voltage	V_a	= 400 V
Screen grid voltage	V_{g2}	= 425 V
Intercepting grid voltage	V_{g3}	= 0 V
Cathode resistance	R_k	= 315 Ohms
Anode rest current	$I_{a0} (V_{g1\text{eff}} = 0)$	= 2×45 mA
Anode current at max. modulation	$I_a (W_o = \text{max})$	= 2×52.5 mA
Screen grid rest current	$I_{g20} (V_{g1\text{eff}} = 0)$	= 2×5.5 mA
Screen grid current at max. modulation	$I_{g2} (W_o = \text{max})$	= 2×19 mA
Optimum matching resistance between the two anodes	$R_{aa'}$	= 9000 Ohms
Max. output	$W_o \text{ max}$	= 30 W
Total distortion	d_{tot}	= 10 %
Grid a.c. voltage required	$V_{g1\text{eff}}$	= 25 V

DYNAMIC DATA for two EL 50 valves in class AB adjustment with fixed negative grid bias

Anode voltage	V_a	= 400 V	800 V
Screen grid voltage	V_{g2}	= 425 V	400 V
Intercepting grid voltage	V_{g3}	= 0 V	0 V
Negative grid bias	V_{g1}	= -35 V	-37.5 V
Anode rest current	$I_{a0} (V_{g1\text{eff}} = 0)$	= 2×25 mA	2×15 mA
Anode current at max. modulation	$I_a (W_o = \text{max})$	= 2×95 mA	2×70 mA
Screen grid rest current	$I_{g20} (V_{g1\text{eff}} = 0)$	= 2×2.5 mA	2×1.25 mA
Screen grid current at max. modulation	$I_{g2} (W_o = \text{max})$	= 2×22 mA	2×20 mA
Optimum matching resistance between the two anodes	$R_{a'a'}$	= 5000 Ohms	16,000 Ohms
Max. output	$W_o \text{ max}$	= 50 W	84 W
Total distortion	d_{tot}	= 3.4 %	6.6 %
Grid a.c. voltage required	$V_{g1\text{eff}}$	= 25 V	23 V

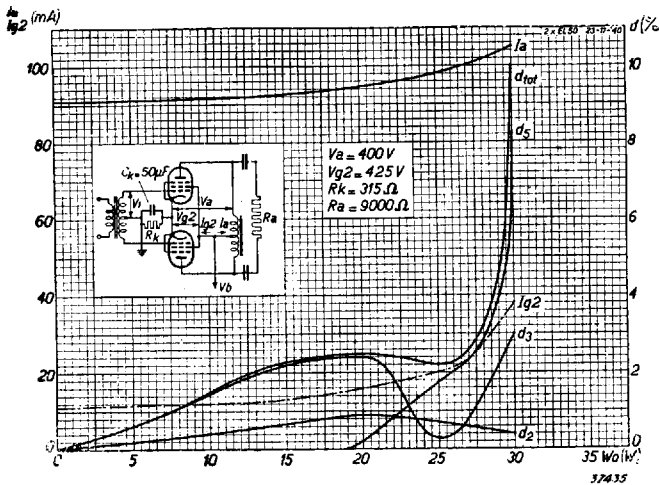

Fig. 6
Anode current I_a , screen grid current I_{g2} , and distortion d as a function of output power W_o of two EL 50 valves in push-pull circuit, with automatic grid bias at $V_a = 400$ V, $V_{g2} = 425$ V and $R_{aa'} = 9000$ ohms.

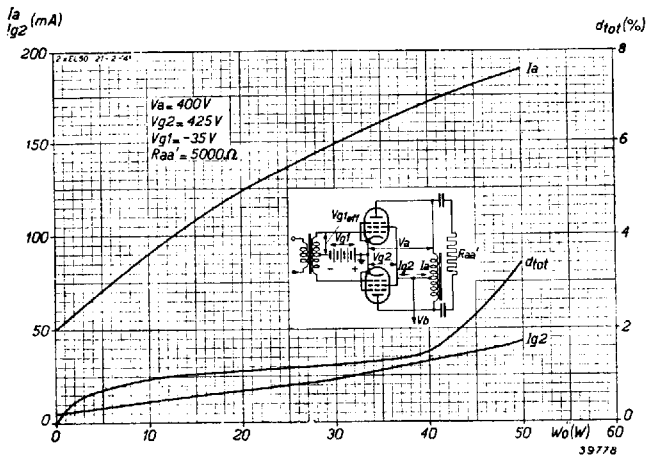

Fig. 7
Anode current I_a , screen grid current I_{g2} and distortion d as function of output power W_o of two EL 50 valves in push-pull circuit with fixed grid bias, at $V_a = 400V$, $V_{g2} = 425V$, $V_{g1} = -35V$ and $R_{aa'} = 5000$ Ohms.

Fig. 8
Maximum output W_o as a function of load resistance $R_{aa'}$ of two EL 50 valves in push-pull circuit with fixed grid bias, at $V_a = 400V$, $V_{g2} = 425V$ and $V_{g1} = -35V$. The broken line $W_{o\max} (+ I_{g1})$ represents the limit to which the valves can be modulated without grid current flowing; in this case, however, the maximum anode dissipation is exceeded.

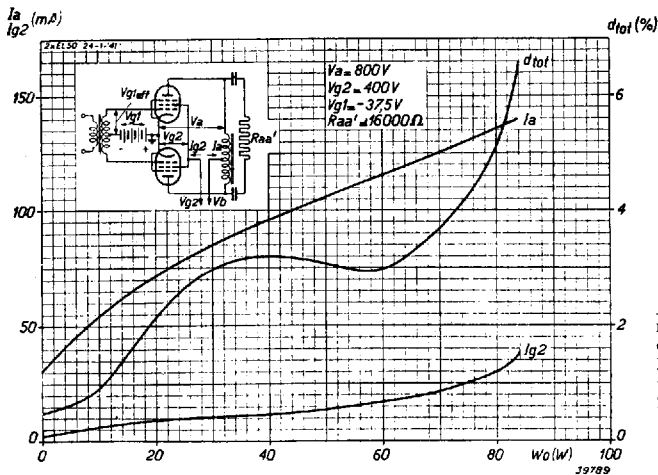
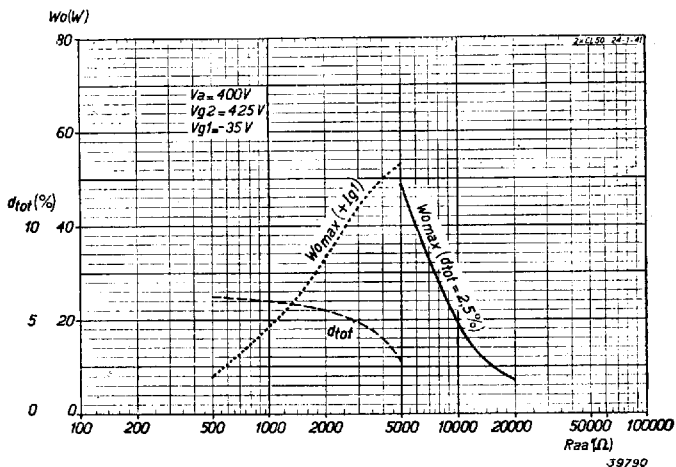

Fig. 9
Anode current I_a , screen current I_{g2} and total distortion d_{tot} as function of the output power W_o of two push-pull EL 50 valves, with fixed grid bias, at $V_a = 800V$, $V_{g2} = 400V$ and $V_{g1} = -37.5V$; $R_{aa'} = 16,000$ Ohms.

EL 50

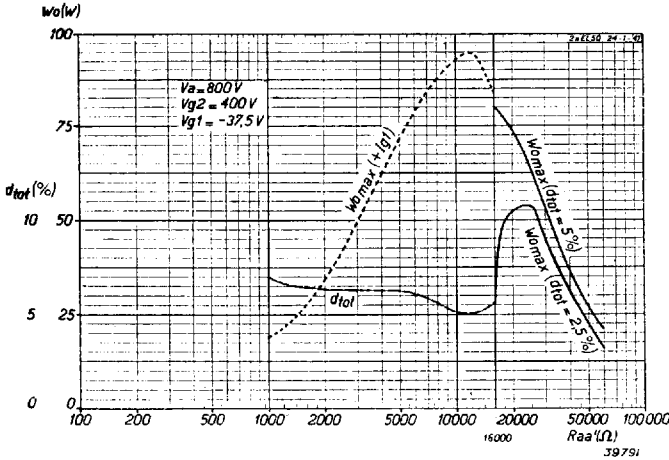

Fig. 10
Maximum output power W_o as a function of load resistance $R_{aa'}$ for two push-pull EL 50 valves with fixed grid bias, at $V_a = 800$ V, $V_{g2} = 400$ V, $V_{g1} = -37.5$ V. The broken line $W_{o\max} (+ I_{g1})$ represents the limit to which the valves can be modulated without grid current flowing, in which case, however, the maximum anode dissipation is exceeded.

MAXIMUM RATINGS

Anode voltage in cold condition	V_{a0} = max. 1600 V
Anode voltage	V_a = max. 800 V
Anode dissipation	W_a = max. 18 W
Anode dissipation, on test	W_{at} = max. 22 W
Screen grid voltage in cold condition	V_{g20} = max. 1000 V
Screen grid voltage	V_{g2} = max. 425 V
Screen grid dissipation ($V_{g1\text{eff}} = 0$ V)	W_{g2} = max. 3 W
Screen grid dissipation ($W_o = \text{max.}$)	W_{g2} = max. 10 W
Cathode current	I_k = max. 120 mA
Grid current commences ($I_{g1} = +0.3 \mu A$)	V_{g1} = max. -1.3 V
Max. external resistance in grid circuit	R_{g1k} = max. 0.7 M Ohms ¹⁾
Max. external resistance in grid circuit	R_{g1k} = max. 0.5 M Ohms ²⁾
Max. external resistance between filament and cathode	R_{fk} = max. 5000 Ohms
Max. voltage between filament and cathode.	V_{fk} = max. 100 V ³⁾

¹⁾ With automatic grid bias.
²⁾ With fixed grid bias.
³⁾ D.C. voltage or effective value of alternating voltage.

APPLICATIONS

Since this valve is employed almost exclusively in push-pull output stages, only the results obtained in this type of circuit will now be discussed.

In this, distinction is made between circuits with fixed grid bias supplied by a separate rectifier and circuits having automatic grid bias. In the latter category no separate rectifier need be employed, but against this there is the disadvantage that the maximum obtainable output power is usually lower than when fixed bias is applied, this drawback becoming all the more manifest according as the anode voltage is increased. If a very high power output is required, of 50 or even 80 W, automatic grid bias will not therefore be used, the explanation of this being as follows.

The highest possible efficiency, that is, the greatest obtainable output power, is furnished by Class A/B, or to a still greater extent, by Class B circuits. In both types of circuit the valves work at the lower bend of the dynamic characteristic which means that the average anode current varies in accordance with the magnitude of the signal. In the case of automatic bias by means of a cathode resistance, the grid bias then

also varies; to avoid exceeding the value of bias relative to the maximum output power, it therefore would be necessary to start from a lower grid bias setting on zero signal. It would then be found, however, that the resultant standing current, whose value depends on the size of the cathode resistance, would become intolerably high, having regard to the maximum anode dissipation. On the other hand, if a start be made from the permissible operating conditions at zero signal strength, the grid bias increases so rapidly with the signal strength that the anode current is interrupted before the valve is even fully modulated.

The maximum power to be delivered is then limited not by the occurrence of grid current, but by distortion of anode current, which becomes the more marked according as the original operating point is taken lower, with the application of a higher anode voltage. Consequently, automatic grid bias is not practicable at anode voltages of more than 400 V.

When automatic bias is incorporated in a push-pull circuit the starting point for zero signal strength must be such that the maximum anode dissipation can be realised. At 400 V anode, the two valves are made to operate at a level where the total anode current will be 90 mA, when they can be modulated to a depth that will not cause the bias to exceed the permissible limit.

Anode current amplitudes are very much smaller than in the case of a fixed bias, permitting of a higher impedance in the anode circuit without thereby reducing the anode voltage too much and, in this way, the delivered output power is not curtailed so much as would otherwise be the case. The slope of the dynamic characteristic is, however, reduced in consequence of the high resistance in the anode circuit, so that when automatic bias is employed, practically the whole of the grid swing is required for maximum modulation.

At 400 V anode voltage, with fixed bias and an anode load of 5000 Ohms, an output of 50 W is obtained, whereas with automatic bias and a load of 9000 Ohms, the output is only 30 W. In both instances the required alternating grid voltage is about 25 V.

Automatic grid bias

Provided the anode voltage does not exceed 400 V, the screen grid voltage can be taken directly from the feed circuit, the maximum screen potential being 425 V. Allowing for a voltage drop of 25 V in the speaker transformer¹⁾, the rectifier circuit should therefore be capable of delivering 425 V.

The distortion, anode current and screen grid current as a function of output power in respect of these values are shown in Fig. 6. Apart from the total distortion, the individual harmonic distortion values have also been measured. For the output power, the actual output of the valve itself has been taken and in practice, therefore, this value must be reduced to the extent of the losses in the output transformer. From the curves it will be seen that the distortion remains only slight up to an output of 27 W ($d_{tot} = 2.6\%$), but increases appreciably above that figure, up to about 10% at 30 W. As already mentioned, the grid bias sets a limit to the power delivered. Fig. 6 shows that for an output of 30 W the average anode current totals 105 mA with a screen current of 38 mA.

A cathode resistance of 315 Ohms will produce a voltage of 45 V which is sufficient to quench the anode current; at still greater modulation depths both valves would then cease to pass anode current and the speech current would be correspondingly interrupted. The marked increase in 5th harmonic in Fig. 6 already points in this

¹⁾ This approximation is arrived at in the following manner. The matching resistance of the primary side of the speaker transformer is usually in the neighbourhood of 10,000 Ohms. Assuming the losses in the winding to be 10% of the output power, the total loss-resistance will be about 1000 Ohms. As a rule this resistance is distributed gradually throughout both primary and secondary windings, so that the loss in the primary alone is about 500 Ohm, corresponding to at least one half of the winding, seeing that the current alternates between the two halves of the transformer. Now, if the current of the one valve averages 50 mA, there will be a voltage drop of 25 V across the transformer winding.

direction. This type of distortion is very troublesome and limits the maximum obtainable output power just as much as the effect of grid current.

Fixed grid bias

A fixed grid bias will commence to show an advantage only at an anode voltage of at least 400 V; whereas Fig. 6, shows that an output power of 30 W is obtainable with automatic bias this becomes 50 W at that anode voltage.

Operating details for the EL 50 in a Class A/B circuit with fixed grid bias are given on page 184.

Fig. 7 shows the anode and screen voltage curves as well as the distortion at $V_a = 400$ V, as function of the output power. The most satisfactory value for the grid bias is -35 V, in which case the best matching resistance between the two anodes is 5000 Ohms. At maximum modulation, the output is 50 W with a total distortion of 3.4%, at which level the screen grid current runs to a value that is just within the permissible limits. The relation between optimum output and the most satisfactory matching resistance for a given setting of the valve is given in Fig. 8.

For values of the anode voltage other than 400 V, details are given in Fig. 11. At voltages above 400 V, the screen grid voltage must be dropped to the maximum rated value by means of a potentiometer; owing to the increase in screen grid current when the valves are modulated, the supply voltage will be reduced by the resistance of the potentiometer itself, this limiting the maximum available output power. This limiting effect becomes the more marked as the anode voltage is raised and at higher voltages it is therefore desirable to stabilise the screen voltage as much as possible, as borne out by the figures given for an anode potential of 800 V.

When the output valves are modulated to the point where grid current flows, an output of 84 W can be attained, provided the screen grid voltage is kept constant at 400 V, with -37.5 V bias and $R = 16000$ Ohms. The curves relative to these operating conditions are shown in Fig. 9; the total distortion is 6.6 %.

If the screen grids are fed from a potentiometer which itself absorbs 40 mA, the screen

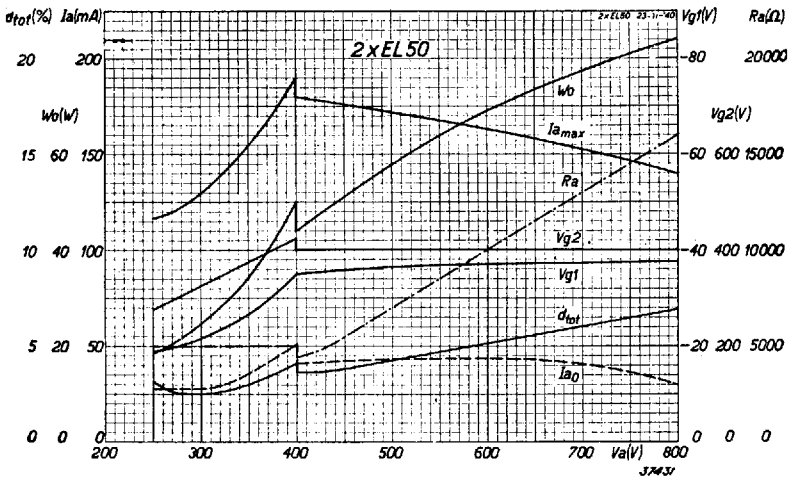

Fig. 11
 Maximum anode current I_{amax} , standing current I_{a0} , screen voltage V_{g2} , grid bias V_{g1} , output power W_o , total distortion d_{tot} and optimum output impedance R_a as a function of available anode voltage V_a of two EL 50 valves in a push-pull circuit with fixed grid bias.

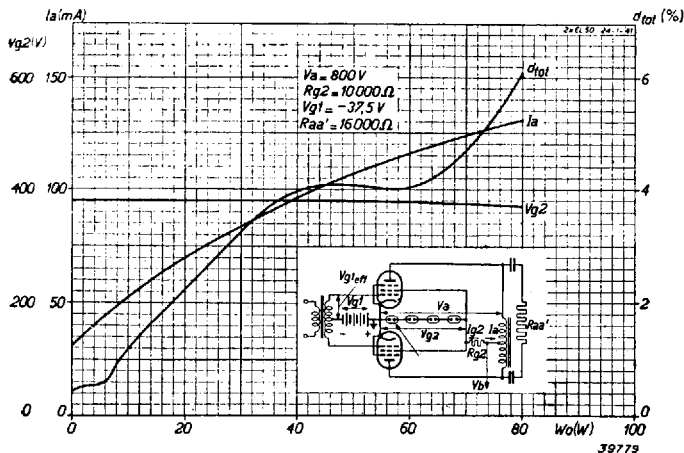

Fig. 12
 The same curves as in Fig. 9, but with respect to the case where the screen voltage is taken from the 800 V supply line across a resistance of 8000 Ohms, being maintained at a constant value by 4 stabiliser tubes type 13201.

grid voltage falls to such an extent under modulation conditions that the maximum output obtainable is only 50 W, due to the displacement of the dynamic characteristic, and this output can also be obtained on an anode voltage of 400 V. It is therefore very necessary to stabilise the screen grid voltage and this may be done by tapping the voltage from the 800 V supply across a resistance of 8000 Ohms and placing four series-connected stabiliser tubes, Type 13201, in parallel with the screen grids. This will keep the voltage sufficiently constant at 380 V and ensure an output of 80 W at maximum modulation. The relative curves are shown in Fig. 12 and it will be seen that they are not very different from these in Fig. 9. Fig. 10 illustrates the relation between the maximum output and the load resistance.

Feeding the amplifier

A push-pull output stage with automatic grid bias will generally not give rise to so many difficulties as the same circuit with fixed bias. The screen grids are then fed directly from the power section and the average anode current is practically independent of the power delivered; the rectifier need not therefore conform to any special requirements. At 400 V anode, the output stage, on maximum modulation, consumes $105 + 40 = 145$ mA which can be supplied by a Type AX 50 rectifier valve, this having a D.C. output of 250 mA which is sufficient for the preceding amplifier valves as well.

For stages with fixed bias in which the average anode current varies considerably with the amplitude of the signal, it is preferable to employ a rectifier circuit having the lowest possible internal resistance, more especially when applicable to 400/425 V operation, in view of the fact that the screen grid voltage is then not stabilised and both anode and screen grid voltages decrease on a rising amplitude. The feed voltage must not be increased in advance, as the maximum screen grid potential would then be exceeded on weak signals.

The gas-filled valve AX 50 is very suitable for the power supply, by reason of its very low internal resistance, provided the smoothing filter does not include a reservoir condenser. The total internal resistance is then equal to that of the choke coil plus the resistance of half the transformer winding: assuming that this is not more than 200 Ohms, an increase of 200 mA in the total current will produce a voltage drop of 40 V. Fig. 11 shows that in this case the optimum output power will be 36 W instead of 50 W, so efforts should be made to reduce the internal resistance still further. On

800 V anode, with stable screen grid voltage, the internal resistance causes a drop of 30 V, yielding an output of 82 W, instead of 84 W.

The AX 50 is inadequate for these operating conditions and the output stage should then be fed from 2 types DCG 2/500 rectifiers of which details are as follows:

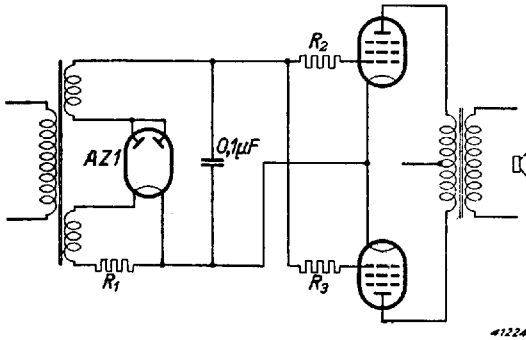

Fig. 13

Circuit employed to obtain fixed grid bias for two push-pull output valves EL 50.

Heater voltage $V_f = 2.0$ V
 Heater current $I_f = 4.5$ A.

Full-wave rectification, on an alternating anode voltage of 1050 V_{eff} gives a maximum D.C. output of 950 V at a maximum of 300 mA.

The method of obtaining screen grid voltage in this instance has already been given: four stabiliser tubes 13201 connected in series are placed in parallel with the screen grids. This combination of 4 tubes ensures a constant working voltage of 380 V over a relatively wide current range. The voltage drop across

the series resistance is then 420 V and, if a resistance of 8000 Ohms is used, the screen grids and stabilisers together must take a current of 52 mA.

In the absence of an input signal the total screen grid current will be about 2 mA, in which case the stabilisers dispose of the remaining 50 mA. At maximum modulation, the screen grids pass a current of 38 mA, leaving 14 mA for the stabilisers, which is just sufficient for efficient stabilisation.

For the grid bias, the arrangement shown in Fig. 13 is recommended, for which purpose the mains transformer should have a separate winding to provide a voltage of

$$V_{eff} = \frac{V_g}{\sqrt{2}}$$

The AZ 1 is suitable as rectifier, the filament being connected in series with a resistance R_1 and in parallel with the heaters of the other valves. In practice this circuit will give rise to no difficulties whatsoever.