

EL731 MANUAL
AC/DC SENSITIVE
EARTH-LEAKAGE RELAY

February 28, 2012

REVISION 2



Copyright © 2012 by Littelfuse Startco

All rights reserved.

Factory default password is 1111

New Password

See Section 3.2.4.

TABLE OF CONTENTS

	PAGE
1. Introduction	1
1.1 General.....	1
1.2 EL731 Features.....	1
1.2.1 Metering.....	1
1.2.2 Data Logging.....	1
1.2.3 Inputs and Outputs.....	1
1.2.4 Operator Interface.....	1
1.2.5 Communications Interface.....	1
2. Installation	2
2.1 System Wiring.....	2
2.1.1 Supply Voltage.....	2
2.1.2 Current Transformer Connections.....	2
2.1.3 Analog Output.....	2
2.1.4 PTC or RTD Input.....	2
2.1.5 Ethernet/IP Communications (optional).....	2
2.1.6 Remote Reset.....	2
2.1.7 Relay Outputs.....	2
2.2 Calibration.....	2
3. Operation and Setup	7
3.1 Display and Indication.....	7
3.1.1 Front-Panel LED Indication.....	7
3.1.1.1 Trip.....	7
3.1.1.2 CT Status.....	7
3.1.1.3 Alarm.....	7
3.1.2 Ethernet/IP Module LED Indication.....	7
3.2 Main Menus.....	8
3.2.1 Metering.....	8
3.2.2 Messages.....	8
3.2.3 Setup.....	8
3.2.3.1 Earth-Fault-CT Input.....	8
3.2.3.2 Temperature Protection.....	8
3.2.3.3 Output Relay Assignments.....	8
3.2.3.4 Analog Output.....	8
3.2.3.5 Miscellaneous Configuration.....	9
3.2.3.5.1 Password.....	9
3.2.3.5.2 Menu Timeout.....	9
3.2.3.5.3 Maintenance.....	9
3.2.4 Password.....	9
3.3 Trip Reset.....	9
4. Theory of Operation	13
4.1 CT1 Theory of Operation.....	13
4.2 CT2 Theory of Operation.....	13
5. Personal Computer Interface	13
5.1 Flash Memory Update.....	13
6. Technical Specifications	14
6.1 EL731.....	14
6.2 Current Sensors.....	15
7. Ordering Information	15
8. Warranty	15
9. Performance Test	16
10. Appendix A	18
11. Appendix B	20

LIST OF FIGURES

	PAGE
1 EL731 Outline and Mounting Details.....	3
2 AC700-SMK Outline and Mounting Details.....	4
3 Panel and Surface Mounting Connections.....	4
4 Connection Diagram.....	5
5 EL731 with installed Anybus Communications Module (AC-700-CUA-0X).....	6
6 EL731 with installed Firmware Upgrade Module (AC-700-CUA-00).....	6
7 EFCT-1 Outline and Mounting Details.....	10
8 EFCT-2 Outline and Mounting Details.....	11
9 EFCT-26 Outline and Mounting Details.....	12
10 Earth-Fault-Test Circuit.....	16

LIST OF TABLES

	PAGE
1. Trip Flash Codes.....	7
2. Network Status LED (NS).....	7
3. Module Status LED (MS).....	7
4. Link/Activity LED (LINK).....	7
5. CT2 Input Filters.....	8
6. Relay Functions.....	8
7. Earth-Fault-Test Record.....	16

DISCLAIMER

Specifications are subject to change without notice. Littelfuse Startco is not liable for contingent or consequential damages, or for expenses sustained as a result of incorrect application, incorrect adjustment, or a malfunction.

This page intentionally left blank.

1 INTRODUCTION

1.1 GENERAL

The EL731 is a microprocessor-based earth-leakage relay for AC, DC, combined AC/DC, and variable-frequency power circuits supplied by solidly or resistance-grounded systems that require earth-leakage detection as low as 30 mA. Earth-leakage metering and two setting levels (alarm and trip) are provided. A temperature-sensor input provides metering and protection for a motor or drive. It is uniquely suited for sensitive earth-fault protection for adjustable-speed drive (ASD) circuits that often operate at low speeds.

Settings and configuration selections provide frequency-response ranges of 0 to 90 Hz, 20 to 90 Hz, 190 to 15,000 Hz, 20 to 15,000 Hz, and 0 to 15,000 Hz. In each case, alarm- and trip-setting ranges are 30 to 5,000 mA.

Three output relays with normally closed and normally open contacts can be programmed for various functions and can be set to operate in the fail-safe or non-fail-safe mode for undervoltage or shunt-trip applications.

Additional features include a 2 x 16-character OLED display, current and temperature metering, programming and menu-navigation push buttons, password security, LED trip and alarm indication, auto-reset alarms and latching trips with front-panel and remote reset, trip memory, 4- to 20-mA analog output, CT verification with LED indication, and conformal coated circuits.

Earth-leakage current is sensed by one or two EFCT-series core-balance zero-sequence current transformers. The trip level range of the earth-leakage circuit is 30 to 5,000 mA. With two CT's connected, the EL731 performs independent metering. Trip-time delay is configurable from instantaneous to two seconds in millisecond increments.

An optional Ethernet/IP communications interface is available. Contact the factory for other communication interface options.

1.2 EL731 FEATURES

- AC Ground Overcurrent (50G/51G)
- DC Ground Overcurrent (79G)
- PTC Overtemperature (49)
- RTD Temperature (38, 49)

1.2.1 METERING

- Earth-Leakage Current
- RTD Temperature or PTC Overtemperature

1.2.2 DATA LOGGING

- Trip Counters
- Alarm Counters

1.2.3 INPUTS AND OUTPUTS

- AC Earth-Leakage Current Transformer (CT2)
- AC/DC Earth-leakage Current Transformer (CT1)
- Remote Reset Input (one shot operation)
- Network Communications (Ethernet/IP – Optional)
- 4-20-mA Analog Output (programmable, loop powered)
- Temperature-Sensor input (RTD or PTC)
- Three output relays, programmable

1.2.4 OPERATOR INTERFACE

- 2 x 16 OLED display
- Display control and programming keys
- LED status indication

1.2.5 COMMUNICATIONS INTERFACE

An optional Ethernet/IP interface is available.

An optional update adapter is available for firmware updates. For ordering information, see Section 7.

2. INSTALLATION

Outline and details for panel-mounting an EL731 are shown in Fig. 1. Insert the EL731 through the cutout and slip the panel-mount clamp over the EL731 body. Slide the panel-mount clamp forward to engage the latch tabs with the mating body retainer grooves. Lock the unit in place by tightening the four clamp screws against the panel.

NOTE: Do not over tighten the clamp screws as this might deform the clamp and release the latch tabs.

Outline and details for surface-mounting the EL731 are shown in Figs. 2. A detailed instruction sheet is included with the optional AC700-SMK Surface-Mounting Hardware Kit.

2.1 SYSTEM WIRING

A typical connection diagram for the EL731 is shown in Fig. 4 and terminal-layout diagrams are shown in Fig. 3.

2.1.1 SUPPLY VOLTAGE

Provide supply voltage from the line side of the controller or from an independent source. Connect supply voltage to terminals 14 and 15 (L1, L2/N) as shown in Fig. 4. In 120-Vac systems, L2/N is designated as the neutral conductor. For direct-current power supplies, use L1 for the positive terminal and L2/N as the negative terminal. Connect terminal 16 (⊕) to ground.

2.1.2 CURRENT TRANSFORMER CONNECTIONS

This earth-leakage relaying system consists of an EL731 earth-leakage relay and one or two EFCT-series current sensors connected as shown in Fig. 4. The system can use CT1 or CT2 individually or combined.

Pass the phase conductors through the CT window(s) and position them in the centre of the opening (for 4-wire and single-phase systems, also pass the neutral conductor through the CT window). Do not pass earth conductors through the CT window. In applications that require shields or drain wires to pass through the CT window, return them through the CT window before connecting them to earth.

Using shielded twisted-pair cable, connect CT1 to terminals 8 and 7 and connect the shield to terminal 6. Current-sensor connections are not polarity sensitive. See Figs. 7, 8 and 9 for current-sensor dimensional drawings. Each EFCT-series sensor includes 6 m (19.2') cable.

Using shielded twisted-pair cable, connect CT2 to terminals 11 and 10, connect the shield to terminal 9. Current-sensor connections are not polarity sensitive. See Figs. 7, 8 and 9 for current-sensor dimensional drawings. Each EFCT-series sensor includes 6 m (19.2') cable.

2.1.3 ANALOG OUTPUT

The 4-20-mA analog output is loop powered. The connection is shown in Fig. 4. The analog output is isolated to 120 Vac from all other EL731 terminals.

2.1.4 PTC OR RTD INPUT

The temperature-sensor input can be configured for either RTD or PTC operation. Connect as shown in Fig. 4.

Select the sensor type in the *Setup | Hardware | Temp Sensor* menu

2.1.5 ETHERNET/IP COMMUNICATIONS (OPTIONAL)

The EL731 supports an Ethernet/IP communications interface. The communications interface module installs through the side of the enclosure as shown in Fig. 5.

To field-install an AC-700-CUA Communications Upgrade Adapter, remove the supply voltage, remove the adapter access cover, insert the adapter, and retain with the supplied screws. Apply the supply voltage.

With the communications module installed, a standard RJ45 network cable can be used to connect the EL731 to an Ethernet/IP network. Configure the interface using the IP config software available at www.startco.ca. The software requires Microsoft Windows operating system. The Ethernet interface supports 10/100-Mbit, full- or half-duplex operation.

2.1.6 REMOTE RESET

If required, connect a normally open switch to the remote-reset input (terminals 12 & 13) as shown in Fig. 4.

2.1.7 RELAY OUTPUTS

The EL731 has three programmable Form-C relay outputs. Program choices are trip, alarm, watchdog or current detected. See Section 3.2.3.3.

2.2 CALIBRATION

If the low-frequency CT1 input is used, the EL731 must be calibrated in order to ensure an accurate current measurement.

To calibrate, connect an EFCT-series current sensor to the EL731 and ensure that no CT-primary current is present. Apply EL731 supply voltage and navigate to menu item *Setup | Protection | CT1 Earth Fault | Calibrate*. Press Enter to begin the calibration process. The CT LED will flash, during the calibration process, which takes about 30 seconds.

If the CT is ever replaced, this procedure must be repeated to maintain current-measurement accuracy.

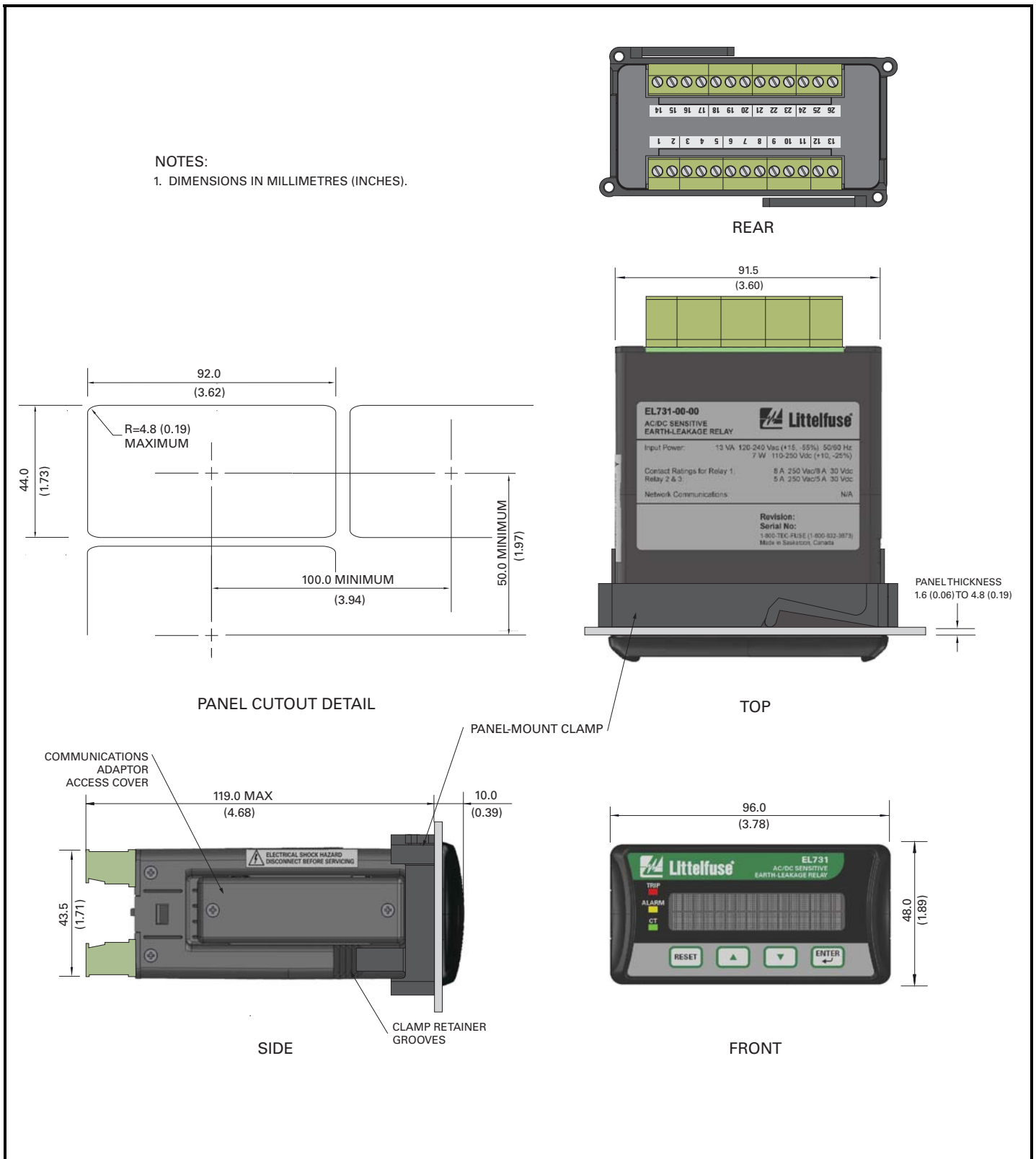

Figure 1. EL731 Outline and Mounting Details.

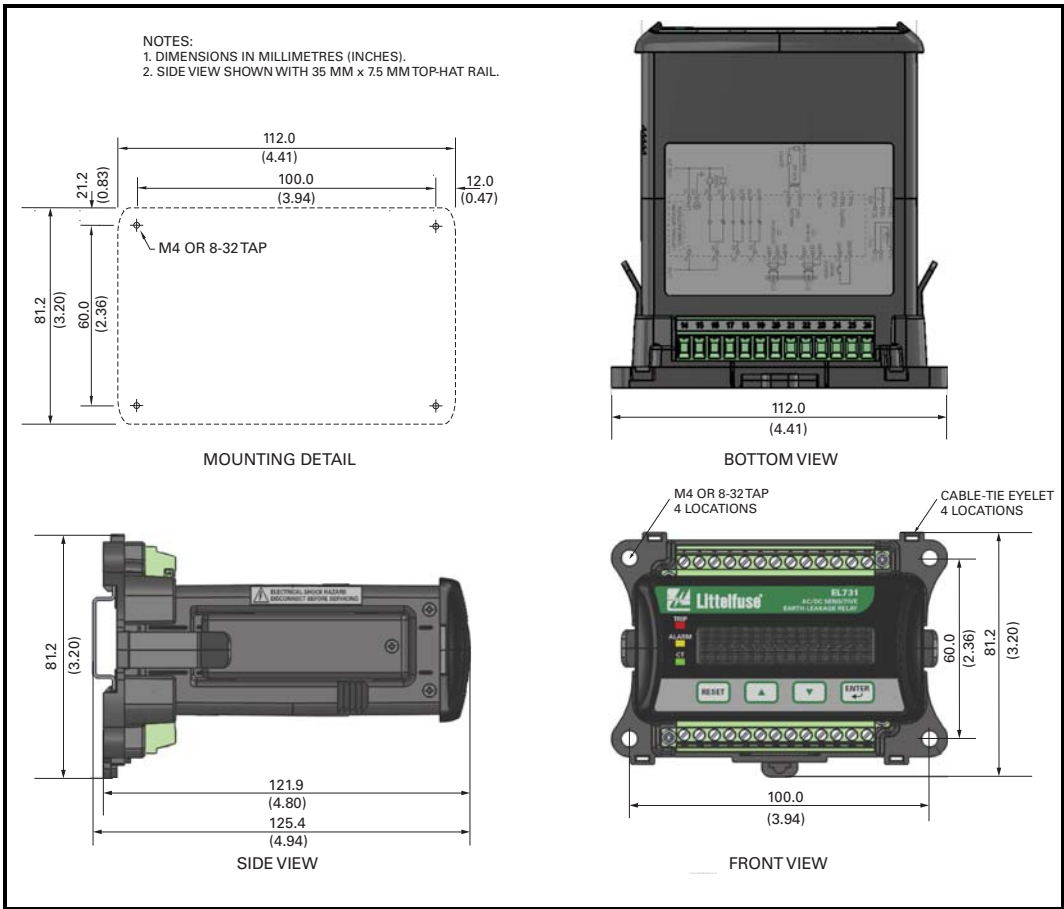

Figure 2. AC700-SMK Outline and Mounting Details.

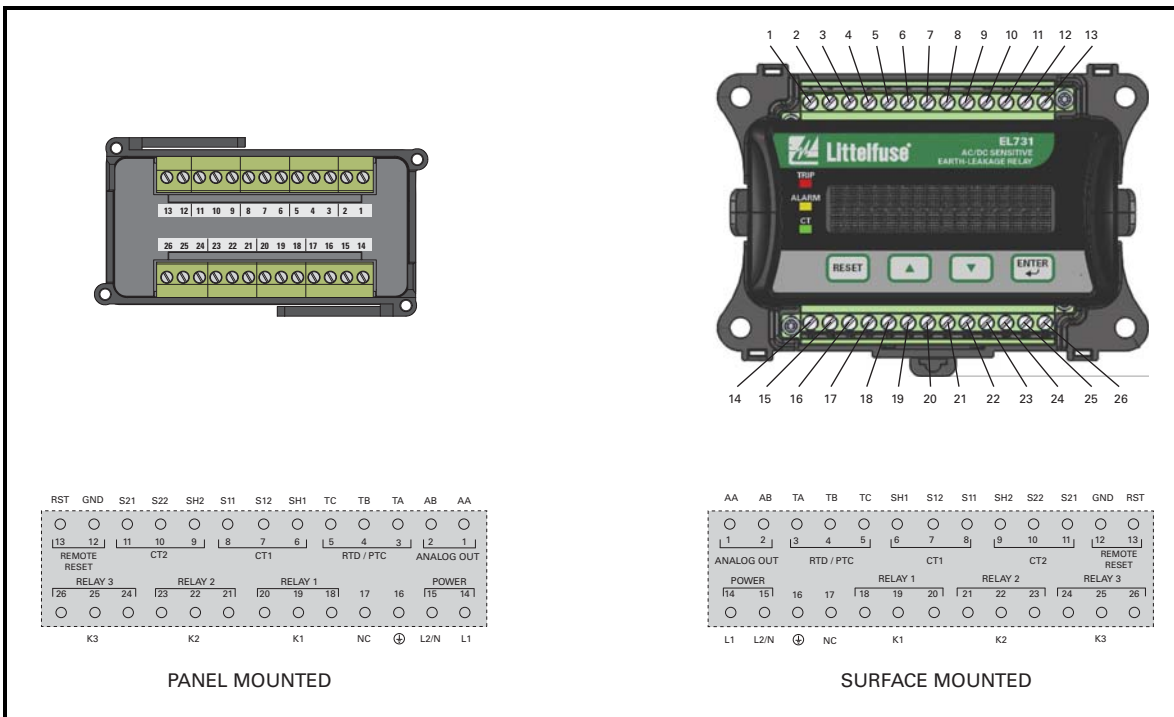

Figure 3. Panel and Surface Mounting connections

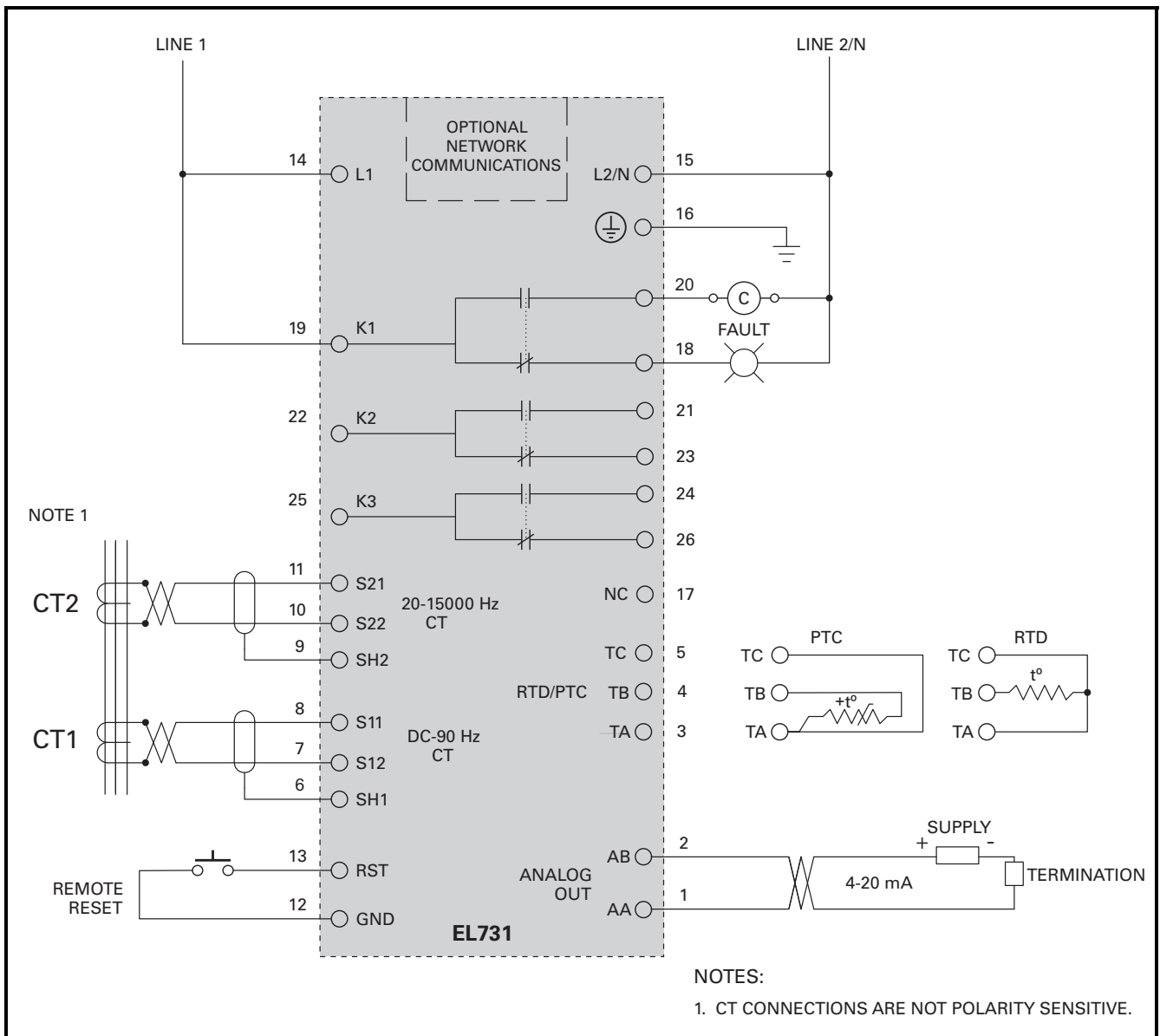

Figure 4. Connection Diagram.



Figure 5. EL731 with installed Anybus Communications Module (AC-700-CUA-03).



Figure 6. EL731 with Firmware Upgrade Module (AC-700-CUA-00).

3. OPERATION AND SETUP

3.1 DISPLAY AND INDICATION

The EL731 front panel has three LED's, a 2-line x 16-character alphanumeric OLED display and four push buttons to navigate through programming, status, and system-information menus. The display will revert to screen-saver mode after 15 minutes. Press any key to exit the screen saver.

The RESET key is used to clear an earth-leakage-fault or overtemperature trip. The fault condition must no longer be present to allow a reset. Continually pressing the reset key will not prevent a trip.

The up and down arrow keys (▲▼) are used to navigate the menu system.

The ENTER key is used to select menu items and to choose settings.

All EL731 settings can be accessed using the EL731 menu system or the optional network communications interface. In the following sections, menu items and setup parameters are listed in italics and are shown in the format displayed on the OLED display.

Menu selection is in the following format:

Menu 1 | Sub Menu 1 | Sub Menu 2 | Sub Menu 3 |...

When browsing a selection list, an asterisk (*) indicates the active item. If the intent is to exit the list and not to change the setting, press ENTER on the selection that has the asterisk (*).

If the item is a string (or numerical) input and no change is desired, press ENTER until the display returns to the menu system. To exit a main-menu list, scroll and select *Exit*.

A menu map is provided in Appendix A at the end of this manual.

3.1.1 FRONT-PANEL LED INDICATION

3.1.1.1 TRIP

The red LED labeled TRIP indicates a trip condition when flashing. Refer to Table 1 for applicable flash codes.

TABLE 1: TRIP FLASH CODES

FAULT	CODES
Overcurrent CT1	1 short, 1 long
Overcurrent CT2	2 short, 1 long
CT1 Detection	3 short, 1 long
CT2 Detection	4 short, 1 long
NVRAM Error	5 short, 1 long
CT1 Calibration Failure	6 short, 1 long
RTD/PTC Trip	7 short, 1 long
User Test	8 short, 1 long
Watchdog	Fast flash

Trip cause is also available on the OLED display through the | *Messages* | *State* menu item.

3.1.1.2 CT STATUS

The green LED labeled CT will flash during CT1 calibration. It will be solid green when CT connections are correct, and off when a CT is connected incorrectly.

3.1.1.3 ALARM

The yellow LED labeled ALARM will be on when measured current is above an alarm setting.

3.1.2 ETHERNET/IP MODULE LED INDICATION

There are three LED's on the optional AC700-CUA-03 Ethernet/IP communications module. Their purpose and indication are shown in Tables 2, 3, and 4.

TABLE 2: NETWORK STATUS LED (NS)

LED STATE	DESCRIPTION
Off	No power or no IP address
Green	On-line, one or more connections established
Green, flashing	On-line, no connections established
Red	Duplicate IP address, FATAL error
Red, flashing	One or more connections timed out

TABLE 3: MODULE STATUS LED (MS)

LED STATE	DESCRIPTION
Off	No power
Green	Controlled by a Scanner in Run State
Green, flashing	Not configured, or Scanner in Idle state
Red	Major fault (EXCEPTION-state, FATAL error)
Red, flashing	Recoverable fault(s)

TABLE 4: LINK/ACTIVITY LED (LINK)

LED STATE	DESCRIPTION
Off	No link, no activity
Green	Link established
Green, flickering	Activity

3.2 MAIN MENUS

The “top” menu item (select Exit in the main menu) displays earth-leakage current(s) as a numeric percent of full scale (5A) and as a bar graph.

3.2.1 METERING

Menu: *Metering*

With *Metering* selected in the main menu, press the ENTER key to display a list of metering options. Use the Up and Down arrow keys to scroll through the options list. Press the ENTER key to display the selected information.

Information available: CT1 primary current (mA), CT2 primary current (mA), combined CT1 and CT2 current (mA), internal EL731 temperature (°C and °F), PTC status, and RTD temperature (°C and °F).

3.2.2 MESSAGES

Menu: *Messages*

Selecting this menu item allows the trip state, alarm state, trip counter, alarm counter, and EL731 running time to be viewed.

3.2.3 SETUP

See Appendix B for a Setup Summary and Setting Record.

3.2.3.1 EARTH-FAULT PROTECTION

Menu: *Setup / Protection / CTx Earth Fault*

The Earth Fault *Enable/Disable* menu enables or disables current monitoring through the selected CT input. When enabled, the system checks to ensure the CT is connected properly. A trip will occur if an EFCT is not connected. See section 3.1.1.1.

The *Trip Time* menu sets the trip delay. The range for this menu item is 0 – 2 seconds in millisecond increments where 0 indicates that as soon as current is detected above the Trip Level, a trip occurs.

The *Trip Level* menu sets the trip level. The setting range is 30 mA to 5 A. The *Alarm Level* setting range is the same as the *Trip Level* range. Trips are latched, requiring a local or remote reset input, and alarms auto-reset.

The *Calibrate* menu applies to CT1 (0 to 100 Hz). When CT1 is used, the EL731 must be calibrated after installation, with CT1 connected and power removed from the load. The CT LED flashes during calibration.

The *Input Filter* menu applies to CT2 (20 to 15,000 Hz) and allows selection of different input filters. The available filters and their descriptions are shown in Table 5.

TABLE 5: CT2 INPUT FILTERS

FILTER	FREQUENCY RESPONSE
No Filter	20 Hz to 15 kHz
Low Pass Filter at 90Hz	20 to 90 Hz
High Pass Filter at 190Hz	190 Hz to 15 kHz

For full-spectrum protection, use CT1 and CT2 and select the High Pass Filter to avoid frequency overlap between the inputs.

3.2.3.2 TEMPERATURE PROTECTION

Menu: *Setup / Protection / PTC Local Temp*

Menu: *Setup / Protection / RTD Local Temp*

Menu: *Setup / Hardware / Temp Sensor*

The temperature-sensor input, at terminals 3, 4, and 5, can be configured as a PTC thermistor or a 100-ohm-platinum RTD (or disabled) in the *Setup / Hardware / Temp Sensor* menu. PTC Overtemperature alarm and trip actions can be selected in the *Setup / Protection / PTC Temperature* menu, or alarm and trip temperature settings and actions can be programmed in the *Setup / Protection / RTD Temperature* menu.

3.2.3.3 OUTPUT RELAY ASSIGNMENTS

Menu: *Setup / Relay Outputs / Relay x*

Each of the three output relays can be assigned to one of the functions listed in Table 6. More than one relay can be assigned the same function.

The default assignments are Trip (fail-safe) for Relay 1, Alarm (fail-safe) for Relay 2, and Watchdog for Relay 3.

TABLE 6: RELAY FUNCTIONS

FUNCTION	ASSIGNMENT OR ACTION
Trip	Relay operates when a trip occurs. Fail-safe or non-fail-safe mode selection is active.
Alarm	Relay operates when an alarm occurs. Fail-safe or non-fail-safe mode selection is active.
Watchdog	Relay is energized when the supply voltage is applied and the EL731 is operating properly.
Current	Relay is energized when current is detected

The fail-safe mode setting for each relay allows the individual relay to be configured as fail-safe (normally energized) or non-fail-safe (normally de-energized).

The *Test* function performs a test of the specified relay’s operation.

3.2.3.4 ANALOG OUTPUT

Menu: *Setup / Analog Output*

A 4-20 mA programmable current output is provided.

Analog % Level enables the output to be configured such that 20 mA corresponds to full scale of the selected CT (5 A) or corresponds to the trip level for the selected CT.

CT Select selects which CT measurement will be represented by the analog output. The selections are *CT1*, *CT2*, or both.

3.2.3.5 MISCELLANEOUS CONFIGURATION

Menu: *Setup / System Config*

Used to access additional system configuration elements described in the following sections.

3.2.3.5.1 PASSWORD

Menu: *Setup / System Config / Change Password*

Menu: *Setup / System Config / Password Enable*

Used to enable and change the EL731 password (four-character numeric field). When enabled, the password must be entered to change a set point. The default password is 1111.

3.2.3.5.2 MENU TIMEOUT

Used to set the time before the system times out due to lack of activity and the menu system returns to the main menu display (See Section 3.2). In *password* mode the password entered will be cleared. The timeout is measured from the last key press.

3.2.3.5.3 MAINTENANCE

Used to clear trip and alarm counters, load defaults, restart the system, and display the firmware version, build date, and serial number.

3.2.4 PASSWORD

Menu: *Password*

With password security active, all set points are locked. To enable programming, the password must be entered through the *Password* menu.

While navigating through the menus when a valid password has been entered, an asterisk (*) is shown at the beginning of the first line of the display.

3.3 TRIP RESET

The RESET button will clear a trip when pressed for two and a half seconds. The trip will only clear if the fault is no longer present. Keeping RESET pressed will not prevent an alarm or trip. If password is enabled, reset will not function until the password has been entered.

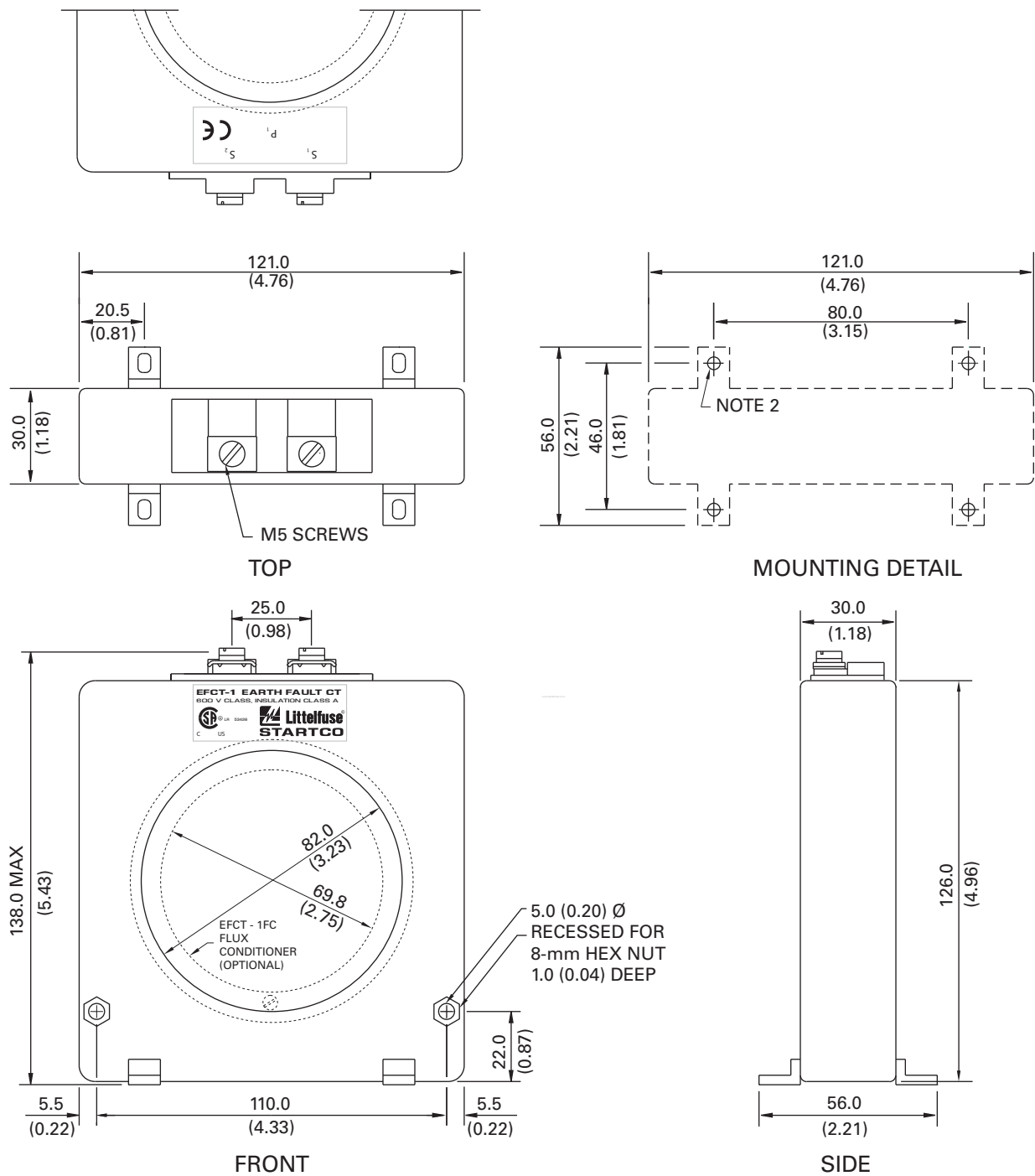

NOTES:

1. DIMENSIONS IN MILLIMETRES (INCHES).
2. MOUNTING SCREWS: M4 OR 8-32.
3. PRESS MOUNTING FEET IN PLACE USING INSTALLATION TOOL PROVIDED.

Figure 7. EFCT-1 Outline and Mounting Details.

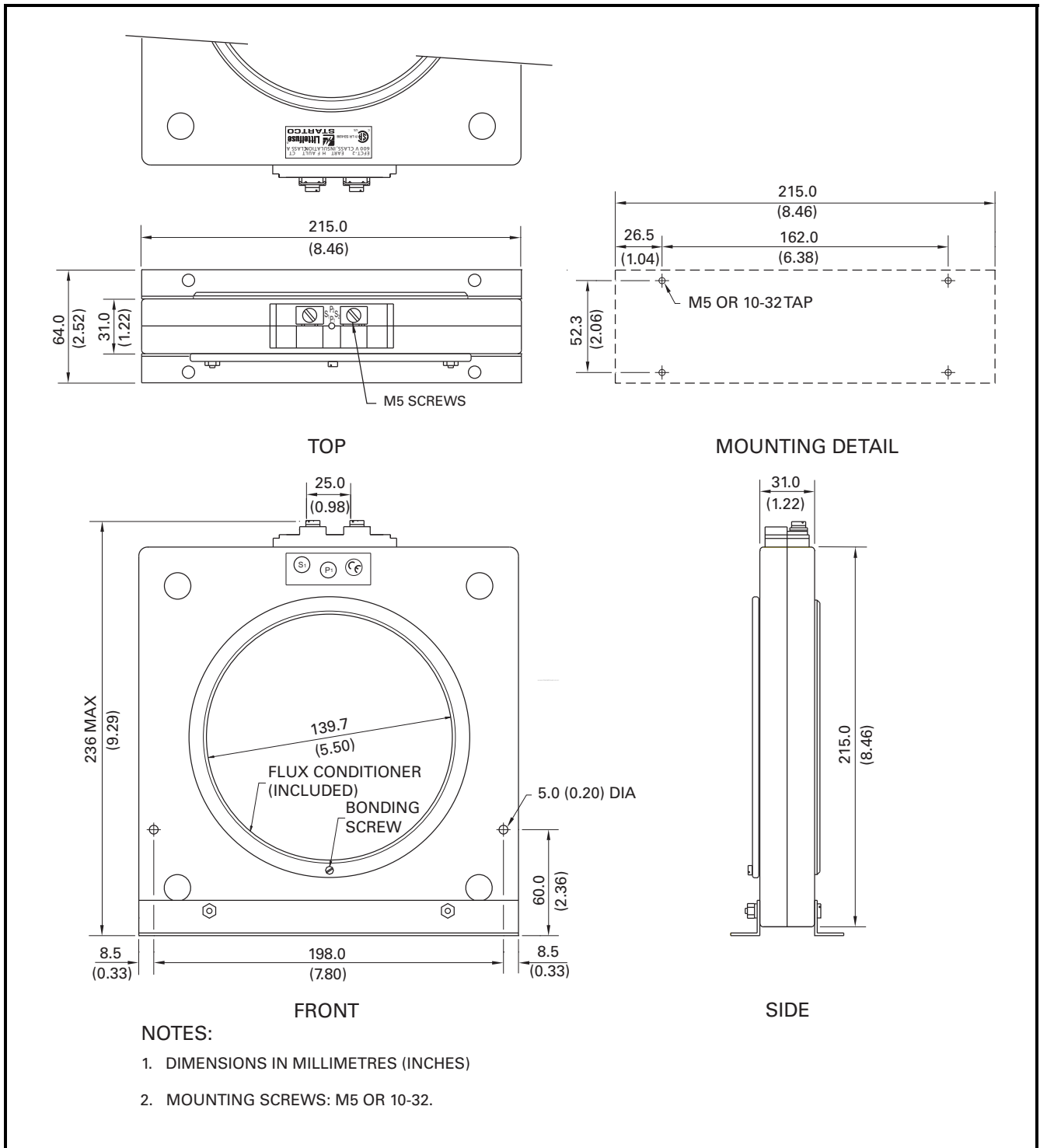

Figure 8. EFCT-2 Outline and Mounting Details.

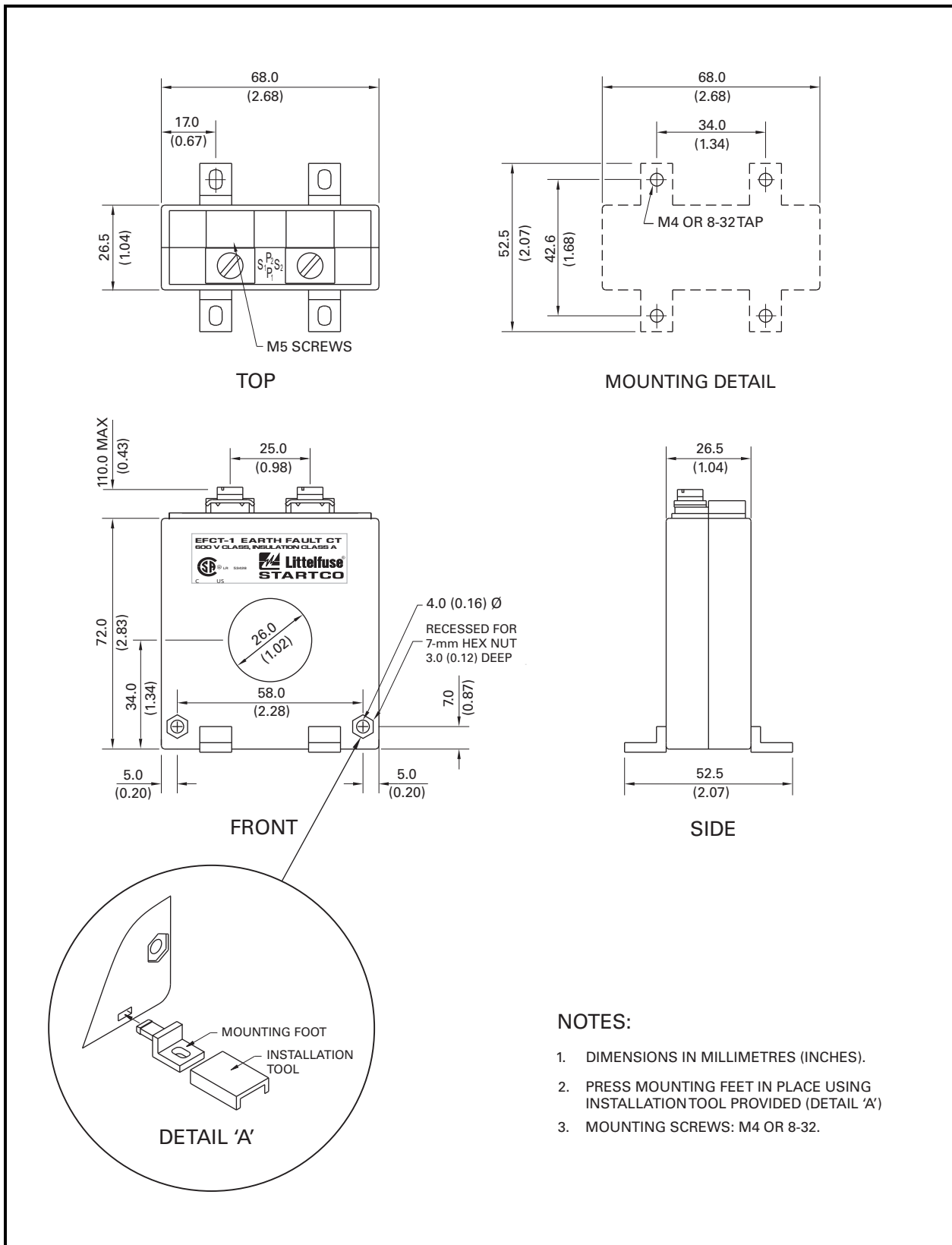

Figure 9 EFCT-26 Outline and Mounting Details.

4. THEORY OF OPERATION

CT1 and CT2 have independent Trip and Alarm current-level and time-delay set points and independent metering. This enables different protection levels and separate metering for the high- and low-frequency ranges.

Full-current metering, summing CT1 and CT2 metering, is provided as an OLED metering selection, an analog output selection, and in optional network communications. To improve full-current-metering accuracy by avoiding band overlap, select the CT2 high-pass filter.

4.1 CT1 THEORY OF OPERATION

The EL731 applies a known signal to the secondary winding of the EFCT-series sensor connected to input CT1. Current flowing in the EFCT primary affects this signal, and its magnitude can be accurately measured across a wide frequency range. The EL731 can measure current as low as 30 mA in a frequency range of 0 to 90 Hz. Open and short EFCT connections are detected.

4.2 CT2 THEORY OF OPERATION

CT2 is a core-balance zero-sequence current-transformer application, with digital filtering to enable a wide spectrum of analysis. There are three digital-filter ranges: Full Range, Low Pass, and High Pass. CT2 includes detection of open or short EFCT-series current sensor wiring.

4.2.1 CT2 FULL RANGE FILTER

The Full Range frequency selection configures the EL731 to respond to the entire frequency spectrum that CT2 is capable of monitoring – 20 to 15,000Hz.

4.2.2 CT2 LOW PASS FILTER

The low pass frequency selection configures the EL731 to respond to only the low end of its frequency range – 20 to 90 Hz.

4.2.3 CT2 HIGH PASS FILTER

The high pass frequency selection configures the EL731 to respond to only the high end of its frequency range – 190 to 15,000 Hz.

5. PERSONAL COMPUTER INTERFACE

5.1 FLASH MEMORY UPDATE

The EL731 control program is stored in flash memory. This allows field upgrades to be made through the upgrade module (optional). The following are required:

- A Windows PC with a USB interface and the SE-Flash program installed. SE-Flash is available at www.startco.ca.
- A file containing the EL731 code (.s19 file)
- A USB cable or TIA232 through CA-945 converter with Ethernet cable.
- An AC700-CUA-00 Upgrade Module

6. TECHNICAL SPECIFICATIONS

6.1 EL731

Supply:

Option 0.....	13 VA, 120 to 240 Vac (+10, -45%) 50/60 Hz; 7 W, 100 to 250 Vdc (+10, -25%)
Option 1.....	7 W, 32 to 60 Vdc (+20, - 25%) 9 VA, 24 to 44 Vac (±10%), 50/60 Hz
Option 2.....	7 W, 16 to 30 Vdc (+20, -25%)

DC and Low Frequency (Current Transformer 1)

Frequency Response.....	DC to 90 Hz
Measurement Method.....	True RMS
Detection Method.....	CT Driven Oscillator
Trip-Level Setting.....	30 to 5,000 mA
Alarm-Level Setting.....	30 to 5,000 mA
Trip-Time Settings.....	0 to 2 s
Trip Accuracies:	
Trip Level.....	-10% at 60 Hz
Time Delay.....	- 5% (Minimum of 35 ms at 60 Hz)

CT EFCT series

Thermal Withstand

Continuous	25 A Earth-Fault Current
1 second.....	400 A Earth-Fault Current
Detection	CT Open & Short

AC/Carrier (Current Transformer 2)

Frequency Response:	
Filter 1	20 to 15,000 Hz
Filter 2	20 to 90 Hz
Filter 3	190 to 15,000 Hz
Measurement Method.....	True RMS
Detection	CT Open & Short
Trip-Level Setting.....	30 to 5,000 mA
Alarm-Level Setting.....	30 to 5,000 mA
Trip Time Settings.....	0 to 2 s

Trip Accuracies:

Trip-Level.....	-10% at 60 Hz
Trip-Time.....	- 5% (minimum 25 ms at 60 Hz)

CT EFCT series

Thermal Withstand

Continuous	25 A Earth-Fault Current
1 second.....	400 A Earth-Fault Current

Output Relays:

Relay 1:

Contact configuration	N.O. and N.C.
Operating Mode.....	Fail-Safe/Non-Fail-Safe
CSA/UL Rating	8 A Resistive, 250 Vac, 8 A Resistive, 30 Vdc

Supplemental Contact Ratings

Make/Carry 0.2 s	30 A
Rating Code.....	B300

Break:

dc.....	50 W Resistive, 150 Vdc
ac.....	2500 VA (PF=1.0) 360 VA (PF=0.4)

Subject to maximums of 8 A and 250 V (ac or dc)

Relays 2 & 3:

Contact configuration	N.O. and N.C.
Operating Mode.....	Fail-Safe/Non-Fail-Safe
CSA/UL Rating	5 A Resistive, 250 Vac, 5 A Resistive, 30 Vdc

Supplemental Contact Ratings

Make/Carry 0.2 s	30 A
Rating Code.....	B300, R300

Break:

dc.....	28 W Resistive
ac.....	1500 VA (PF=1.0) 360 VA (PF=0.4)

Subject to maximums of 5 A and 250 V (ac or dc)

—Terminals.....	Wire Clamping, 24 to 12 AWG (0.2 to 2.5 mm ²) conductors
-----------------	--

4–20 mA-Analog Output:

Type	Loop Powered
Range	4 to 22 mA
Full Scale (20 mA).....	5 A Primary
Loop Voltage.....	8 to 26 Vdc
Load	500 Ω (maximum with 24-Vdc supply)
Isolation	120 Vac
Parameter	CT1, CT2, or Combined Current

Communication Options

Network Protocol	Ethernet/IP
------------------------	-------------

Display Type	2x16 OLED
--------------------	-----------

Dimensions: (Body)

Height	44 mm (1.7")
Width	92 mm (3.6")
Depth	100 mm (3.9")

Dimensions: (Bezel)

Height	48 mm (1.9")
Width	96 mm (3.8")
Projection.....	13.7 mm (0.54")

Shipping Weight.....	0.45 kg (1 lb)
----------------------	----------------

PTC-Thermistor Input:

Cold Resistance 1500 Ω maximum at 20°C
 Trip Level 2800 Ω ± 100 Ω
 Reset Level 1500 Ω ± 100 Ω
 Sensor Current 1 mA maximum

RTD Input:

RTD Type 3 wire Pt100
 Range -40 to 200°C with open
 and short detection
 Sensor Current 1 mA
 Lead Compensation 25 Ω maximum
 Accuracy 3°C

Environment:

Operating Temperature -40 to 60°C
 Storage Temperature -55 to 80°C
 Humidity 85% Non-Condensing

PWB Conformal Coating MIL-1-46058 qualified
 UL QMJU2 recognized

Certification CSA



CSA C22.2 No.14 Industrial Control Equipment
 UL 508 Industrial Control Equipment
 UL 1053 Ground Fault Sensing and Relaying
 Equipment

Surge Withstand ANSI/IEEE C37.90.1-2002
 (Oscillatory and Fast
 Transient)

6.2 CURRENT SENSORS

EFCT-1:

Current Ratio 5:0.05 A
 Insulation 600-V Class
 Window Diameter 82 mm (3.2")
 Shipping Weight 900 g (2.0 lb)

EFCT-2

Current Ratio 5:0.05 A
 Insulation 600-V Class
 Window Diameter 139.7 mm (5.5")
 Shipping Weight tbd

EFCT-26

Current Ratio 5:0.05 A
 Insulation 600-V Class
 Window Diameter 26 mm (1.0")
 Shipping Weight 450 g (1.0 lb)

7. ORDERING INFORMATION

EL731- -00

Future Use

Communications:
 0= None
 3= Ethernet/IP

Supply:
 0 – Universal AC/DC Supply
 1 – 48Vdc/24Vac Supply
 2 – 24Vdc Supply

EFCT-1 Earth-Fault Current Transformer,
 82-mm (3.2") window
 EFCT-2 Earth-Fault Current Transformer,
 with Flux Conditioner
 139-mm (5.5") window
 EFCT-26 Earth-Fault Current Transformer,
 26-mm (1.0") window
 EFCT-1FC Flux Conditioner, 70 mm (2.7") Window

PGA-0500 Analog Percent Current Meter

AC700-SMK DIN Rail and Surface-Mount Adapter

AC700-CUA-0

Communications
 Upgrade
 Adapter

Adapter Type
 0 – Firmware Upgrade
 Module
 3 – Ethernet/IP

8. WARRANTY

The EL731 Earth-Leakage Relay is warranted to be free from defects in material and workmanship for a period of 5 years from the date of purchase.

Littelfuse Startco will (at Littelfuse Startco's option) repair, replace, or refund the original purchase price of an EL731 that is determined by Littelfuse Startco to be defective if it is returned to the factory, freight prepaid, within the warranty period. This warranty does not apply to repairs required as a result of misuse, negligence, an accident, improper installation, tampering, or insufficient care. Littelfuse Startco does not warrant products repaired or modified by non-Littelfuse Startco personnel.

This page intentionally left blank.

Menu Level
1 2 3 4 5 6

APPENDIX A
EL731 MENU MAP

Earth Leakage Current→	{CT1 and/or CT2 current in percent as value and bar graph}	
Metering ▶		
CT1 Current→	{CT1 Current in Milliamperes}	
CT2 Current→	{CT2 Current in Milliamperes}	
Full Current→	{CT1+CT2 Current in Milliamperes}	
Internal Temp→	{EL731 Temperature Measurement}	
PTC Status→	{PTC state}	
RTD Temperature→	{RTD Temperature in Celsius & Farenheit}	
Exit→	{Return to Previous Menu}	
Messages ▶		
Trip State→	{Trip Status}	
Alarm State→	{Alarm Status}	
Trip Counter→	{Trip Counter}	
Alarm Counter→	{Alarm Counter}	
Running Time→	{Running Hours}	
Exit→	{Return to Previous Menu}	
Setup ▶		
Protection ▶		
CT1 Earth Fault ▶		
Enable/Disable→	[E/D]	
Trip Time→	[X]	
Trip Level→	[X]	
Alarm Level→	[X]	
Calibrate→	[P]	
Exit→	{Return to Previous Menu}	
CT2 Earth Fault ▶		
Enable/Disable→	[E/D]	
Trip Time→	[X]	
Trip Level→	[X]	
Alarm Level→	[X]	
Input Filter→	[E]	
Exit→	{Return to Previous Menu}	
PTC Local Temp ▶		
Trip Action→	[E/D]	
Alarm Action→	[E/D]	
RTD Local Temp ▶		
Trip Action→	[E/D]	
Trip Level→	[X]	
Alarm Action→	[E/D]	
Alarm Level→	[X]	
Exit→	{Return to Previous Menu}	
Relay Outputs ▶		
Relay 1 ▶		
Function→	[E]	
Fail-safe Mode→	[E/D]	
Test→	[P]	

Menu Level		3	4	5	6
1	2				
			Relay 2 ▶	Exit→ {Ret. to Prev Menu}	
				Function→ [E]	
				Fail-safe Mode→ [E/D]	
				Test→ [P]	
				Exit→ {Ret. to Prev. Menu}	
			Relay 3 ▶	Function→ [E]	
				Fail-safe Mode→ [E/D]	
				Test→ [P]	
				Exit→ {Ret. to Prev. Menu}	
		Exit→	{Return to Previous Menu}		
		Analog Output ▶	Analog % Level→ [E]		
			CT Select→ [E]		
		Exit→	{Return to Previous Menu}		
		Hardware ▶	Temp. Sensor→[PTC Sensor / RTD Sensor / Disabled]		
		System Config ▶	Change Password→[S]		
			Password Enable→ [E/D]		
			Menu Timeout→ [X]		
			Maintenance→		
				Clear Counters→ [P]	
				Load Defaults→ [P]	
				Restart System→ [P]	
				Firmware Ver.→ [P]	
				System Version→ [P]	
				ROM Version→[S]	
				Build Date→ [S]	
				Serial Number→ [S]	
				Exit→ {Ret. to Prev Menu}	
		Exit→	{Return to Previous Menu}		
		Exit→ {Return to Previous Menu}			
		Password→[S]			
		Exit→ {Return to Main Menu}			

LEGEND

- ▶ : This menu item has a sub menu, press enter view sub menu.
- : Last menu, press enter key to view data.
- [P]: Prompt for response from user
- [Y/N]: Yes/No.
- [X]: Numeric.
- [S]: String. Specific string format may be required.
- [E]: Selection is from a list of values.
- [EA]: Ethernet Address (xxx.xxx.xxx.xxx).
- [E/D]: Enable/Disable.

**APPENDIX B
SYSTEM PARAMETERS**

PARAMETER AND SETTINGS	MIN	DEFAULT	MAX	UNIT	PROGRAM SELECTION
Protection					
CT1 Earth Fault					
Enable/Disable		Enable			<input type="checkbox"/> Enable <input type="checkbox"/> Disable
Trip Time	0	30	2,000	ms	
Trip Level	30	60	5,000	mA	
Alarm Level	30	30	5,000	mA	
CT2 Earth Fault					
Enable/Disable		Enable			<input type="checkbox"/> Enable <input type="checkbox"/> Disable
Trip Time	0	30	2,000	ms	
Trip Level	30	60	5,000	mA	
Alarm Level	30	30	5,000	mA	
Input Filter		Full Range			<input type="checkbox"/> Full Range, <input type="checkbox"/> 190 Hz High Pass <input type="checkbox"/> 90 Hz Low Pass
PTC Local Temp					
Trip Action		Disabled			<input type="checkbox"/> Enabled <input type="checkbox"/> Disabled
Alarm Action		Disabled			<input type="checkbox"/> Enabled <input type="checkbox"/> Disabled
RTD Local Temp					
Trip Action		Disabled			<input type="checkbox"/> Enabled <input type="checkbox"/> Disabled
Trip Level	40	150	200	Degree Celsius	
Alarm Action		Disabled			<input type="checkbox"/> Enabled <input type="checkbox"/> Disabled
Alarm Level	40	125	200	Degree Celsius	
Relay Outputs					
Relay 1: Function		Trip	—		<input type="checkbox"/> Trip <input type="checkbox"/> Current <input type="checkbox"/> Watchdog <input type="checkbox"/> Alarm
Mode		Failsafe			
Relay 2 Function		Alarm			<input type="checkbox"/> Trip <input type="checkbox"/> Current <input type="checkbox"/> Watchdog <input type="checkbox"/> Alarm
Mode		Failsafe			
Relay 3 Function		Watchdog			<input type="checkbox"/> Trip <input type="checkbox"/> Current <input type="checkbox"/> Watchdog <input type="checkbox"/> Alarm
Mode		Failsafe			
RY Pulse Time					
Analog Output					
CT Select		CT1 Current			<input type="checkbox"/> CT1 Current <input type="checkbox"/> CT2 Current <input type="checkbox"/> Full Current
Analog % Level		Disabled			<input type="checkbox"/> Enabled <input type="checkbox"/> Disabled
Hardware					
Temp Sensor		Disabled			<input type="checkbox"/> Disabled <input type="checkbox"/> PTC Sensor <input type="checkbox"/> RTD Sensor
System Config					
Change Password	0000	1111	9999		
Password Enable		Disabled			<input type="checkbox"/> Enabled <input type="checkbox"/> Disabled
Menu Timeout	1	10	60	minutes	<input type="checkbox"/> Enabled <input type="checkbox"/> Disabled