

EL

Model EL7768MS 640 X 480 Pixel Electroluminescent Display

Operations Manual

Product Profile

The EL7768MS is a compact, rugged, high-resolution electroluminescent (EL) display which replaces the bulky CRT for virtually all microcomputer-based product designs. Its compact dimensions keep overall system size to an economical minimum. It is designed to function in extreme environments, and its crisp display is viewable under most lighting conditions at wide viewing angles. It is easy to install and reduces system integration costs.

The EL7768MS is a 640 column by 480 row flat panel display. The display format is VGA compatible, with sixteen patterned gray scale levels, and supports all standard VGA modes. Input required is CRT-type and TTL-compatible. The pixel aspect ratio is 1:1.

The EL7768MS display requires DC power and five basic types of signals to operate:

1. Video Data or pixel information (D0, D1, D2, D3, D4, D5)
2. Video Clock, pixel clock, or dot clock (VCLK)
3. Horizontal Sync (HSYNC)
4. Vertical Sync (VSYNC)
5. Blanking (BLANK)

Technology

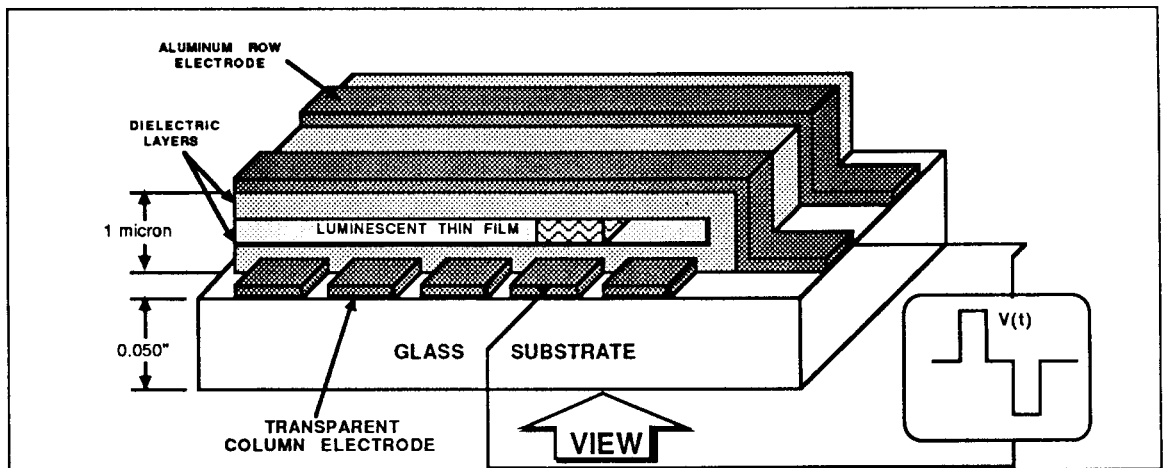

The display consists of an electroluminescent glass panel and a mounted circuit board with control electronics.

The EL glass panel is a solid-state device with a thin film luminescent layer sandwiched between transparent dielectric layers and a matrix of row and column electrodes. The row electrodes, in back, are aluminum; the column electrodes, in front, are transparent. The entire thin film device is deposited on a single glass substrate. A circuit board is connected to the back of the glass substrate. Components are mounted on this circuit board within the same area as the electroluminescent viewing area on the glass panel. The circuit board is connected to the glass with conductive silicone rubber interconnect technology. The result is a flat, compact, reliable and rugged display device.

In the EL7768MS, the 640 column electrodes and 480 active row electrodes are arranged in an X-Y formation with the intersecting areas performing as pixels. Voltage must be applied to both the correct row electrode and the correct column electrode to cause a lit pixel. Operating voltages required are provided by a DC/DC converter. The converter may be either mounted to the display or mounted elsewhere in the final assembly.

PLANAR[®]
The Definition of Quality

Modes

Mode Selection

The 7768MS display is timing and pin compatible with the feature connector on IBM's® XT/AT style VGA board. Pins 1-26 on the feature connector connect to pins 1-26 on the EL7768MS. Pins 27-34 may be left disconnected. The display is compatible with all VGA modes. It reads the polarity of HSYNC and VSYNC at the rising edge of BLANK and determines if there are 480, 400 or 350 non-interlaced displayed rows in the selected mode. The display automatically centers the image vertically, and if the mode requires 720 displayed pixels, every ninth pixel is automatically deleted.

Mode Characteristics

MODE NUMBER	TYPE	TEXT FORMAT	BOX SIZE	VSYNC FREQ.	PIXELS (SOFTWARE)	DOUBLE SCAN†	BORDER SIZE (HxV)††
0,1	text	40 x 25	8 x 8	70 Hz	320 x 200	yes	8/7
2,3	text	80 x 25	8 x 8	70 Hz	640 x 200	yes	8/7
0*, 1*	text	40 x 25	8 x 14	70 Hz	320 x 350	no	8/6
2*, 3*	text	80 x 25	8 x 14	70 Hz	640 x 350	no	8/6
0+, 1+	text	40 x 25	9 x 16	70 Hz	360 x 400	no	9/7
2+, 3+	text	80 x 25	9 x 16	70 Hz	720 x 400	no	9/7
4,5	graphics	40 x 25	8 x 8	70 Hz	320 x 200	yes	8/7
6	graphics	80 x 25	8 x 8	70 Hz	640 x 200	yes	8/7
7	text	80 x 25	9 x 14	70 Hz	720 x 350	no	9/6
7+	text	80 x 25	9 x 16	70 Hz	720 x 400	no	9/7
D	graphics	40 x 25	8 x 8	70 Hz	320 x 200	yes	8/7
E	graphics	80 x 25	8 x 8	70 Hz	640 x 200	yes	8/7
F	graphics	80 x 25	8 x 14	70 Hz	640 x 350	no	8/6
10	graphics	80 x 25	8 x 14	70 Hz	640 x 350	no	8/6
11	graphics	80 x 30	8 x 16	60 Hz	640 x 480	no	8/8
12	graphics	80 x 30	8 x 16	60 Hz	640 x 480	no	8/8
13	graphics	40 x 25	8 x 8	70 Hz	320 x 200	yes	4/7

Modes 0 through 6 emulate the support provided by the IBM® Color Graphics Adapter (CGA). Mode 7 emulates the support provided by the IBM® Monochrome Display Adapter (MDA). Modes D, E, F, 0*, 1*, 2*, 3*, and 10 emulate the support provided by the IBM® Enhanced Graphics Adapter (EGA).

† Double Scan is an IBM®-compatible VGA card feature.

†† Borders are not displayed by the 7768MS, but are properly compensated for in the timing diagram. See T5 and T10 on the timing diagram.

Additional Features

16-Level Gray Scale: The display is capable of displaying sixteen levels of gray. Color software is displayed in the same gray scale sequence as an IBM® monochrome CRT. This gray scale circuitry manipulates video data to achieve three true levels of gray and 13 patterned levels of gray. The three true (single pixel) gray levels are: off, half intensity, and full (on) intensity. The 13 dithered gray levels are achieved by using a 2x2-pixel pattern. All character attributes are readable. All 640x480 pixels are individually addressable. The true gray level of any pixel is determined by the color video data-to-pixel pattern mapping as shown on page 9. The designer may select monochrome (non-gray, on and off only) operation by inputting identical data to D0, D1, D2 and D3. See page 9. To maintain long term symmetric voltage balance, the half intensity polarity is reversed periodically resulting in a slight, single-frame flash once every 2 hours.

Normal Operation: Normal display operation provides a minimum pixel luminance of 30 fL. The power requirements for a typical full screen of VGA text (when all "E's" are displayed) is about 12 watts.

Self Test Mode: The display is capable of performing self-scan functions whereby all pixels are illuminated. Only DC power need be applied to activate self-scan.

IBM® is a registered trade mark of International Business Machines Corp.

For ordering information of el7768ms and other EL Displays, please visit <http://www.eldisplays.com/el7768ms/> or call +1-888-394-4998.

Electrical Characteristics

The EL7768MS consists of a display, DC/DC converter, and interconnecting cable as shown below:

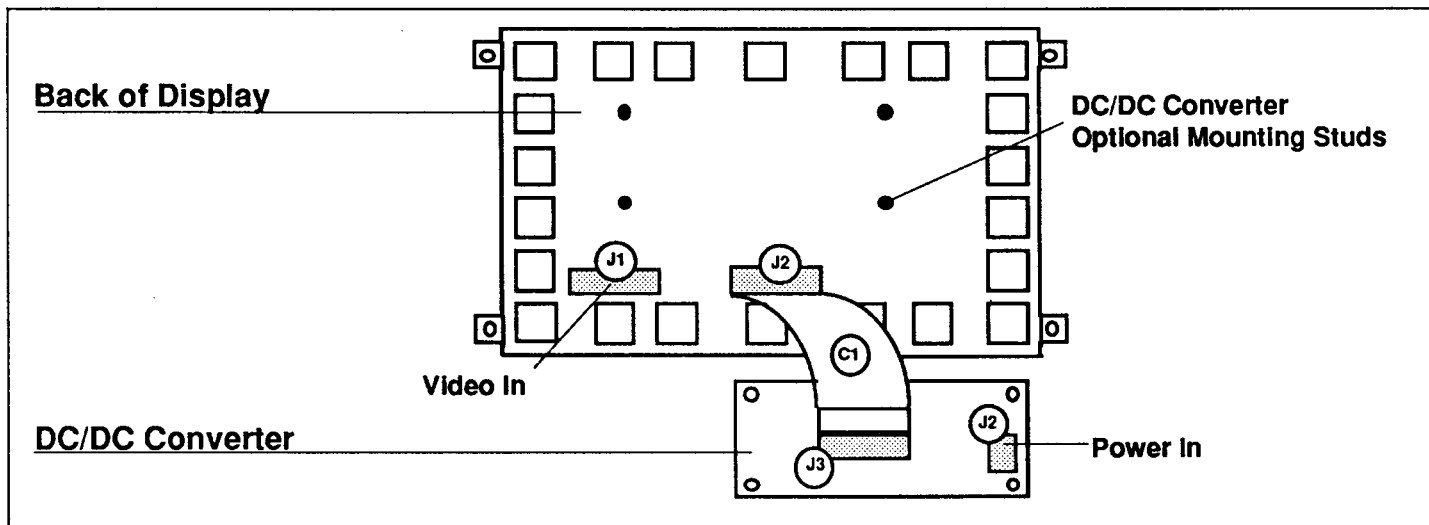

Display Video Input at J1

Pin(s)	Signal	Symbol	Description
1 3 5 15 17 19 21	Ground	GND	Signal return.
7 9 11 11 13 14 16 23 25 27 29 30 31 32	Not Used	n/c	These pins are reserved.
2	Video Data	D0	D0 is LSB.
4	Video Data	D1	
6	Video Data	D2	
8	Video Data	D3	D3 is MSB.
10	Video Data	D4	D4 and D5 are presently unused but are reserved for future use.
12	Video Data	D5	D4 and D5 are presently unused but are reserved for future use.
18	Data Clock	VCLK	Provides the necessary signal to latch in the information present on the data signal. All control signals are referenced to the data clock.
20	Blanking	BLANK	A low input level blanks the display. The trailing edge of blanking is used to position the display horizontally and sense the display mode.
22	Horizontal Sync	HSYNC	One of the signals used to determine display modes. Each row of video data is ended by the HSYNC signal. See timing diagrams.
24	Vertical Sync	VSYNC	One of the signals used to determine display mode. A new frame is initiated by the leading edge of the VSYNC signal. See timing diagrams.
26	Self-Test		Performs self-test when high. Normal operating mode is low. Internally pulled high.
28	Display Enable		Internally pulled high. Default is enabled, ground to disable.
33	Test	/TEST	Reverses drive polarity. Used for factory test. Internally pulled high if left disconnected.
34	Reserved		Reserved for future use. Internally pulled high if left disconnected.

Pins 1 through 26 are mechanically, electrically and timing compatible with the feature connector on IBM's® XT/AT VGA card. A 26-conductor mass terminated ribbon cable can be connected between the feature connector and pins 1-26.

For ordering information of el7768ms and other EL Displays, please visit <http://www.eldisplays.com/el7768ms/> or call +1-888-394-4998.

350 rows x 640 columns (IBM® modes 2*, 3*; F; 10)**350 rows x 720 columns (IBM® mode 7)**

Columns	320	640	720	units	Columns	320	640	720	units				
T1 Vertical Border†	6	6	6	tHSYNC	T6 Horizontal Border†	8	8	9	tVCLK				
T2 Vertical Front Porch†	32	32	32	tHSYNC	T7 Horizontal Front Porch†	4	11	9	tVCLK				
T3 VS Pulse Width†	2	2	2	tHSYNC	T8 HSYNC Pulse Width	≤49	≥64≤99	≥100	tVCLK				
T4 Vertical Back Porch†	53	53	53	tHSYNC	T9 Horizontal Back Porch	≤15	40†	45†	tVCLK				
T5 Vertical Border	6	6	6	tHSYNC	T10 Horizontal Border	8	8	9	tVCLK				
Sync polarity: + HSYNC, -VSYNC					VCLKs per HSYNC					400	800	900	tVCLK
350 mode determination at first rising edge of BLANK after the rising edge of VSYNC: HSYNC low, VSYNC high					HSYNCs per VSYNC					449	449	449	tHSYNC

† Ignored by the display controller, values are for typical system timing.

400 rows x 640 columns (IBM® modes 2, 3; 6; D; E)**400 rows x 720 columns (IBM® modes 2+, 3+; 7+)****400 rows x 320 columns (IBM® modes 0,1; 4,5; 13)****400 rows x 360 columns (IBM® modes 0+, 1+)**

Columns	320	320(13)	360	640	720	units	Columns	320	320(13)	360	640	720	units					
T1 Vertical Border†	7	7	7	7	7	tHSYNC	T6 Horizontal Border†	8	4	9	8	9	tVCLK					
T2 Vertical Front Porch†	6	6	6	6	6	tHSYNC	T7 Horizontal Front Porch†	3	6	4	8/11	9/13	tVCLK					
T3 VSYNC Pulse Width†	2	2	2	2	2	tHSYNC	T8 HSYNC Pulse Width	≤49	≤49	≥50≤63	≥64≤99	≥100	tVCLK					
T4 Vertical Back Porch†	27	27	27	27	27	tHSYNC	T9 Horizontal Back Porch	≤15	≥16	≤15	37/40†	40/45†	tVCLK					
T5 Vertical Border	7	7	7	7	7	tHSYNC	T10 Horizontal Border	8	4	9	8	9	tVCLK					
Sync polarity: - HSYNC, +VSYNC							VCLKs per HSYNC						400	400	450	800	900	tVCLK
400 mode determination at first rising edge of BLANK after the rising edge of VSYNC: HSYNC high, VSYNC low							HSYNCs per VSYNC						449	449	449	449	449	tHSYNC

† Ignored by the display controller, values are for typical system timing.

480 rows x 640 columns (IBM® modes 11; 12)

Columns	640	units	Columns	640	units		
T1 Vertical Border†	8	tHSYNC	T6 Horizontal Border†	8	tVCLK		
T2 Vertical Front Porch†	3	tHSYNC	T7 Horizontal Front Porch†	8/11	tVCLK		
T3 VSYNC Pulse Width†	2	tHSYNC	T8 HSYNC Pulse Width	≥64≤99	tVCLK		
T4 Vertical Back Porch†	24	tHSYNC	T9 Horizontal Back Porch	40	tVCLK		
T5 Vertical Border	8	tHSYNC	T10 Horizontal Border	8	tVCLK		
Sync polarity: - HSYNC, -VSYNC			VCLKs per HSYNC			800	tVCLK
480 mode determination at first rising edge of BLANK after the rising edge of VSYNC: HSYNC high, VSYNC high			HSYNCs per VSYNC			525	tHSYNC

† Ignored by the display controller, values are for typical system timing.

350 Row Display Mode

• Control

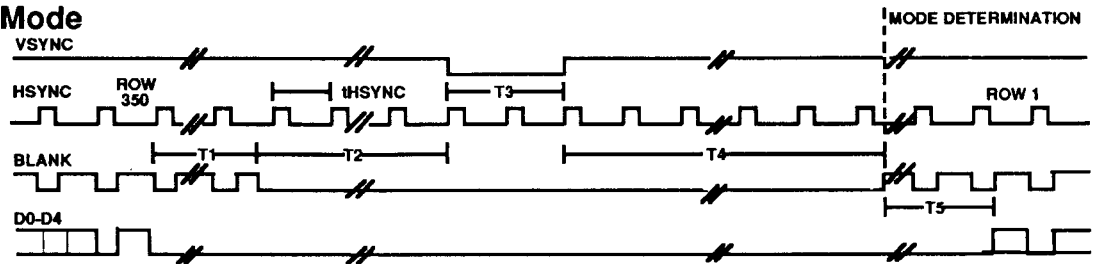

• Data

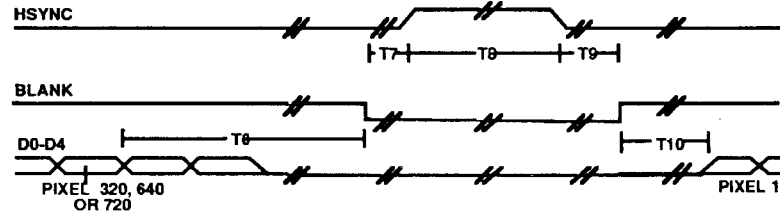

400 Row Display Mode

• Control

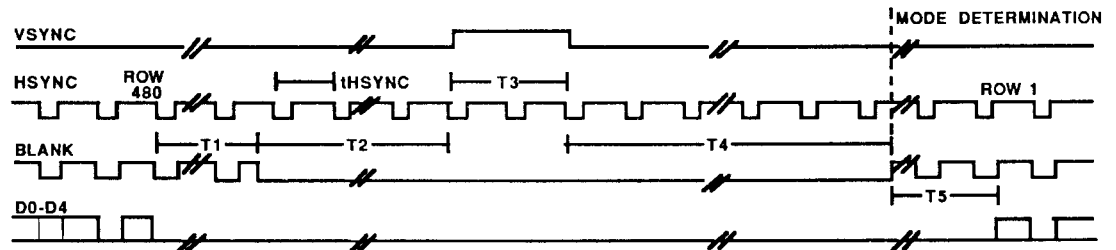

• Data

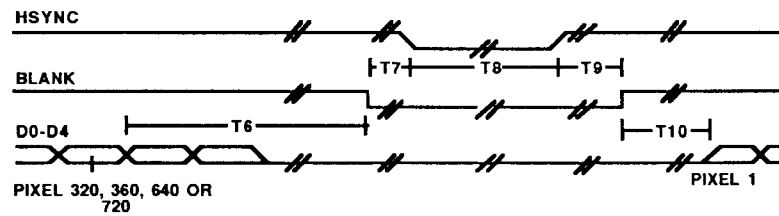

480 Row Display Mode

• Control

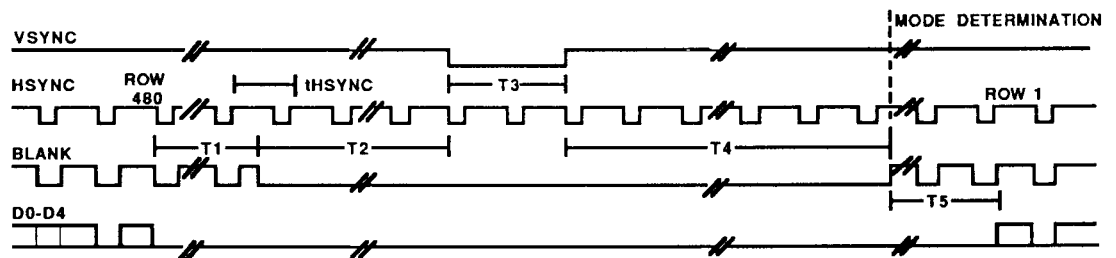

• Data

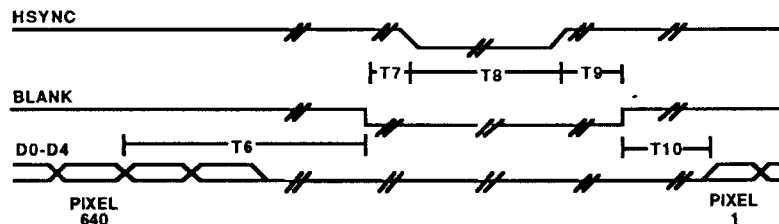

Setup and Hold Timing

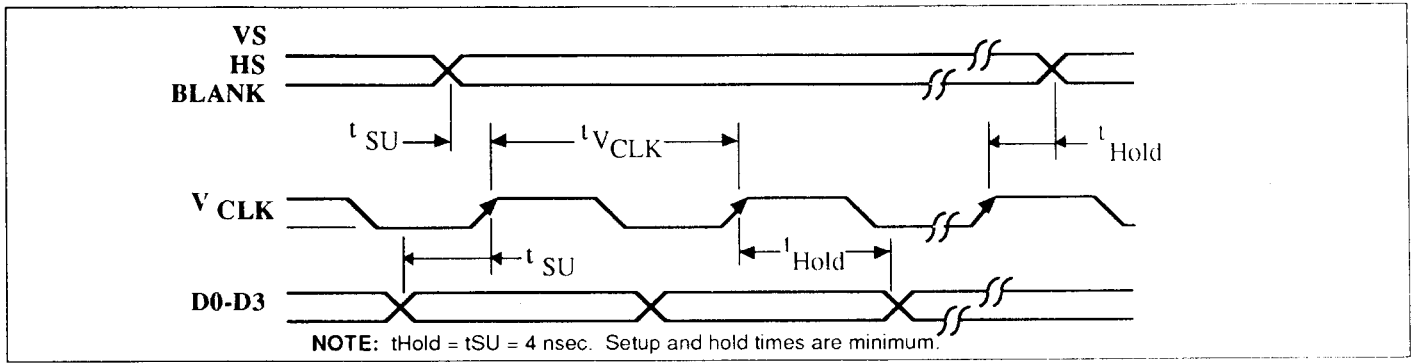

Mode	t_{VCLK}	f_{VCLK}
2+, 3+, 7, 7+	35.31 nsec	28.322 MHz
2,3,2*, 3*, 6, E, F,10,11,12	39.72 nsec	25.175 MHz

Mode	t_{VCLK}	f_{VCLK}
0+, 1+	70.62 nsec	14.161 MHz
0, 1, 0*, 1*, 4, 5, D, 13	79.44 nsec	12.588 MHz

Video Electrical Specifications

(TTL compatible)

	Min	Max	Units
V_{imax} maximum input voltage	-0.5	$V_L+0.5$	V
$I_{in \ max}$ maximum input current	-20	+20	mA
V_{il} low-level input voltage	-0.3	0.8	V
V_{ih} high-level input voltage	2.0	5.0	V
I_{in} input current		± 1	μA

$T_a = 0^\circ C$ to $55^\circ C$ unless otherwise stated

Input Terminations

All data, sync and clock signal inputs are terminated as shown in the schematic below. Control signals are terminated with a $3K\Omega$ resistor pull-up to +5V. Video input signals must be "74ACT" TTL level compatible.

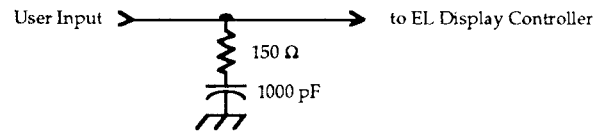

Interconnections

Connector	Manufacturer	Model Number
Display		
J1 connector:	T&B Ansley	609-3407 or equivalent
J1 mating connector: (customer supplied)	T&B Ansley	609-3430 or equivalent
26-pin VGA feature connector mate: (customer supplied)	3M	3462-0001 or equivalent
J2 connector:	T&B Ansley	609-2607 or equivalent
DC/DC Converter		
J3 connector:	T&B Ansley	609-2627 or equivalent
J2 connector:	Amp	640456-4 or equivalent
J2 mating connector: (customer supplied)	Amp	643814-4 or equivalent
Cable		
C1 connectors (both):	T&B Ansley	609-2630
Note: C1 is a Planar supplied cable which facilitates mounting the DC/DC converter on the display.		
Note: In most cases, an AT power supply has sufficient excess capacity to drive the EL7768MS and its DC/DC converter if no modem is in the system. Molex body 15-24-4047 and Molex pins 02-08-1206 will connect to the AT power supply.		

Mounting and Connector Locations

The display has four mounting tabs, two located on each side of the display. When mounting, use all four of these tabs; failure to do so will invalidate the product warranty. The vibration and shock specifications listed are accurate only if all four mounting tabs are used. To avoid breaking the glass, use appropriate length standoffs and do not deflect the mounting tabs out of the plane of the display when tightening the mounting hardware. The EL7768MS has optional mounting studs for the DC/DC converter which can be mounted separately or directly to the rear of the display. Vibration specifications assume the DC/DC converter is mounted separately.

EL7768MS Display

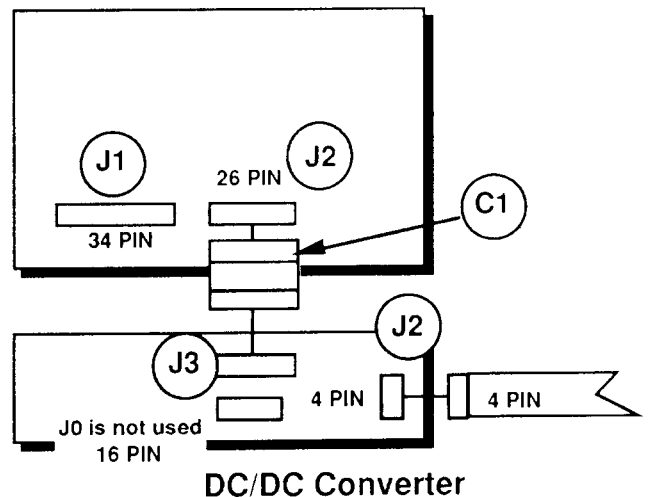

DC/DC Converter

DC Power Input Specifications

Description	Min	Nom	Max	Units
Input voltage (VH)	11.4	12.0	12.6	VDC
Input voltage absolute max (VHmax)	--	--	15.0	VDC
Input current (IH) (VH=Min)	--	1.0	2.0	A
Input current if VL is internal	--	1.2	2.2	A
Input voltage (VL)	4.8	5.0	5.25	VDC
Input voltage absolute max (VLmax)	--	--	7.00	VDC
Input current (IL) (VL=min)	--	120	200	mA
Input current if VL is internal	--	0	--	mA

The DC/DC Converter can be configured to accept +5 and +12V input (VL and VH) or +12V (VH) only input by using J4. It is set for +12V only operation when shipped from the factory so that VL is generated internally by the DC/DC converter. The display and DC/DC converter are matched at the factory.

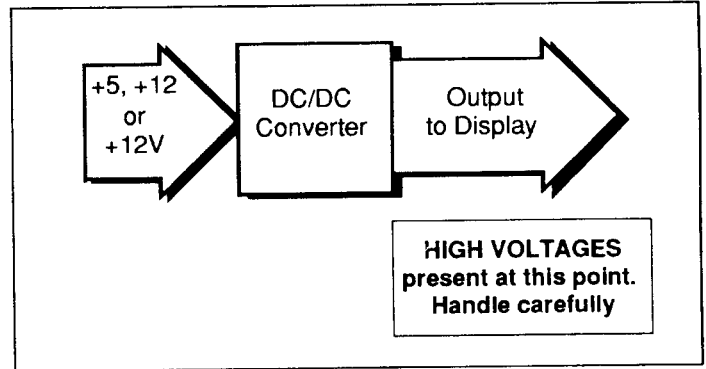

DC/DC Converter Calibration

The DC/DC converter cannot be tested separately. It requires an active low enable signal from the display to activate the high voltage section. The display provides this signal after detecting the presence of video signals at its input.

The DC/DC converter has been properly calibrated at the factory to the EL display by means of a voltage output adjustment. The converter should not need adjustment in the field. If the DC/DC converter and display become separated, the following procedure can be used to verify the proper voltage setting.

1. Ensure power to the DC/DC converter is off.
2. Turn the trimpot on the DC/DC converter fully counterclockwise (ccw).
3. Connect the DC/DC converter to the display using the 26 pin flat cable.

4. Apply a full on video pattern to the display (full white field). At the factory, calibration is done with all pixels on.
5. Set the DVM to measure a 235 VDC voltage.
6. Connect the positive lead of the DVM to the V(ALL ON) test point on the display. Connect the ground lead of the DVM to GND test point on the display.
7. Apply power to the DC/DC converter.
8. Note the voltage statement on the display. A sample is shown at right:
9. Adjust the trimpot on the DC/DC converter clockwise (cw) until the voltage reading of the DVM is equal to the V(ALL ON) voltage $\pm 1V$, as specified on the display. Do not exceed 235V.
10. Calibration is complete.

PS SN: _____
V (ALL ON):+ _____

DC/DC Converter - PS512-2

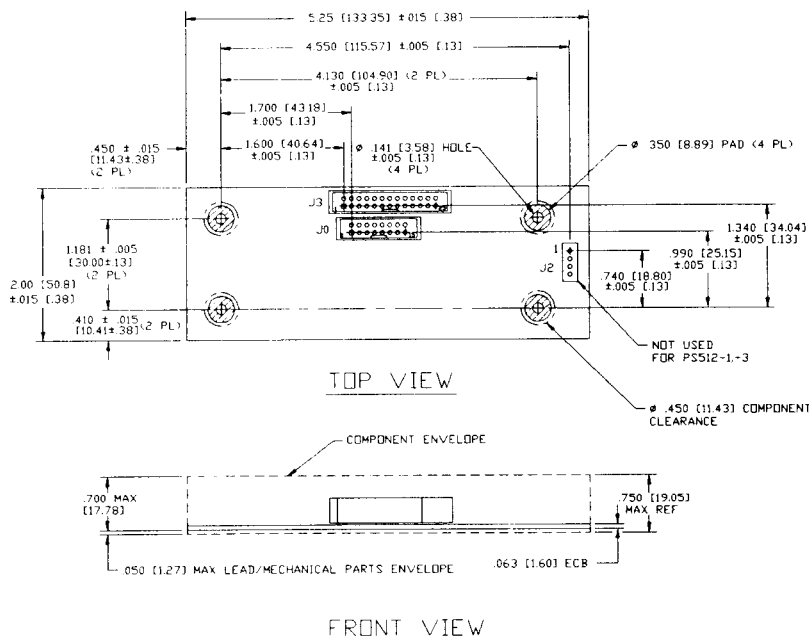

DC/DC Converter Voltage Input at J2

Pin(s)	Symbol	Description
1	VH	+12V DC
2 3	GND	ground
4	VL	+5V DC

J4 Configuration on DC/DC Converter

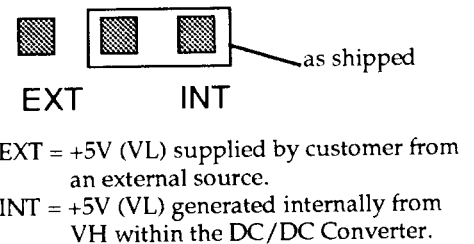

Operational Specifications

Environmental

Temperature

Operating	0°C to +55°C
Operating Survival	-20°C to +70°C
Non-Operating	-40°C to +75°C

The EL display will function at operating survival temperatures for a 24-hour period and incur no damage but may not meet some specifications above the +55°C operating limit.

Humidity

93% relative humidity (non-condensing) as verified by standard IEC 68-2-3.

Altitude

Operating	0 to 16,000 ft. above sea level
Non-Operating	16,000 to 58,000 ft. above sea level

Per standard IEC 68-2-13.

Vibration (Random)

20–500 Hz:	
ASD Level	0.02 g ² /Hz (3.1 g rms)

Measured without DC/DC Converter mounted.
Per standard IEC 68-2-36 Test Fd.

Shock

Magnitude	50 g peak acceleration
Duration	11 ms (half sine wave)
Number of tests	3 on each of 6 surfaces

Measured with DC/DC Converter mounted.
Per standard IEC 68-2-27 Test Ea.

Mean Time to Failure

Greater than 30,000 hours

Electromagnetic Compatibility

The display is capable of being operated in a final product that complies with FCC Docket, Part 15, Subpart J, Class B and VDE 0871 Level B when enclosed in a suitable package.

The display bezel is not connected to the display power, ground or logic signals. The bezel plating may not guarantee connection to the steel bezel unless special hardware is utilized by the customer. Generally, regulatory compliance can be obtained without use of an ITO or mesh EMI filter. The greatest source of EMI in the display system is the 28.322 MHz clock.

Optical

Display Color

Peak emission wavelength	585 nm (Yellow-Orange)
--------------------------	------------------------

Pixel Luminance

ON luminance	Typical 35 fL (120 cd/m ²) pixel Minimum 30 fL (103 cd/m ²) pixel
--------------	--

Luminance measured at center of display screen, 60 Hz frame rate, full ON pattern 15 (see page 9), 25°C ambient temperature.

OFF luminance	0.3 fL maximum (1.0 cd/m ²) pixel
---------------	--

Luminance measured at center of display screen, 60 Hz full OFF pattern, 25°C ambient temperature.

ON luminance uniformity	Maximum difference 26%
-------------------------	------------------------

Measured using pattern 15 (see page 9) between any two of five points, corners and center:
Non-uniformity % = (1 - min luminance/max luminance) x 100.

ON luminance variation (temp.)	Maximum variation ±15% from 25°C over 0°C to +55°C range.
--------------------------------	--

ON luminance variation (time)	Maximum difference ±10% at 25°C within 10,000 hours.
-------------------------------	---

Fill Factor

40.5% (luminance area/total active area.)

Viewing Angle

Greater than 160° viewing cone (80° viewing angle from the axis normal to the display face).

Optional Filter

For best performance in high light levels, an amber or neutral gray circular polarizing filter with anti-reflective coating or etch is the usual choice. In lower light levels, good performance can be achieved with a less expensive non polarized gray filter. These filters will make the reflective electrodes of the display darker and will improve the contrast ratio. The etched or anti-reflective coating on the filter should face the user, and the taped side of the filter should face the display.

Safety and Health

Safety

The display will not inhibit the end product from obtaining any of the following certifications: UL114/478, CSA 154, IEC 380.

Health

An inert, non-toxic, silicon-based oil is used in the construction of the electroluminescent panel.

Installation and Handling

Unpacking

Electrostatic Caution

The display and DC/DC converter assemblies use CMOS and power MOS-FET devices. These components are electrostatic sensitive. Unpack, assemble and examine these assemblies in a static-controlled area only. When shipping either assembly, use packing materials designed for protection of electrostatic-sensitive components.

Unpack and check contents of shipping container against invoice in a static-controlled area. Use anti-static bags for storage of displays and DC/DC converters awaiting assembly processes. Any discrepancies in materials received and invoiced should be noted to Planar within 10 days.

Cleaning

Display Face	Any non-abrasive mild glass cleaner can be used.
Filter	Do not clean a Planar-supplied acrylic filter with alcohol.
Circuit Boards	Only isopropyl alcohol should be used on the ECB assemblies.

Avoiding Burn-in

As with any other display, it is prudent to use screen-saver software to avoid burn-in of images that remain on the screen for extended periods.

16-Level Patterned Gray Scale

D3	D2	D1	D0	COLOR	IBM® VALUE*	PATTERN
0	0	0	0	Black	0	0
0	0	0	1	Blue	5	1
0	0	1	0	Green	17	5
0	0	1	1	Cyan	28	8
0	1	0	0	Red	8	2
0	1	0	1	Magenta	11	3
0	1	1	0	Brown**	20	6
0	1	1	1	White	40	11
1	0	0	0	Gray	14	4
1	0	0	1	Lt. Blue	24	7
1	0	1	0	Lt. Green	45	12
1	0	1	1	Lt. Cyan	50	13
1	1	0	0	Lt.Red	32	9
1	1	0	1	Lt. Magenta	36	10
1	1	1	0	Yellow	56	14
1	1	1	1	White(Hi Inten)	63	15

* IBM® Gray Scale Value is a color summing to monochrome algorithm (30% red, 59% green, 11% blue) identical to that implemented in the IBM® BIOS.

** Brown is implemented differently in some modes and the pattern may differ from that shown.

See also page 2 for more information on the implementation of the 16-level gray scale.

Mechanical Characteristics

Display External Dimensions

Height	7.64 in.	194 mm
Width, exclusive of mounting tabs	9.70 in.	246 mm
Width	10.35 in.	263 mm
Depth	0.7 in.	17.8 mm
Weight	21 oz. max	595 grams

Mounting DC/DC converter to display makes total depth 1.49". See drawings for detailed dimensions and tolerances.

DC/DC Converter Characteristics

Height	2.00 in.	51 mm
Width	5.25 in.	133 mm
Depth	0.75 in.	19 mm
Weight	4 oz. max	113 grams

Display Viewing Area Characteristics

Active area	Height	6.093 in.	154.76 mm
	Width	8.125 in.	206.40 mm
Pixel pitch	Height	0.0127 in.	0.3226 mm
	Width	0.0127 in.	0.3226 mm
Pixel size	Height	0.009 in.	0.2286 mm
	Width	0.009 in.	0.2286 mm
Pixel matrix	640 pixels horizontal by 480 pixels vertical		

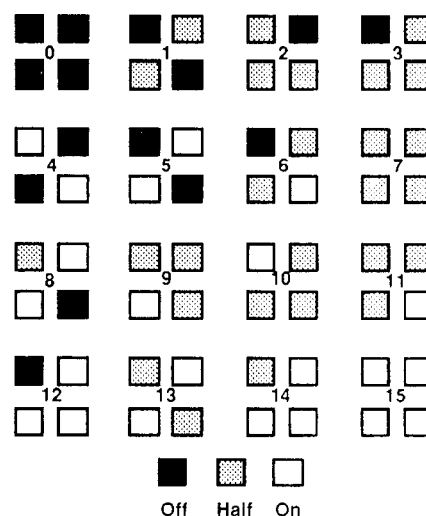

Pixel Patterns for 16-Level Gray Scale

Although patterns 9 & 10 (Lt.Red, Lt. Magenta) have the same area luminance levels, boundaries between filled areas will be discernible. In the 720x400 default text mode (mode 3+) and also in text modes 2+, 3+, and 7, the default text brightness level (white) is mapped to full on (pattern 15) and high intensity white is mapped to pattern 11, not as shown in the table at left.

Display (front view)

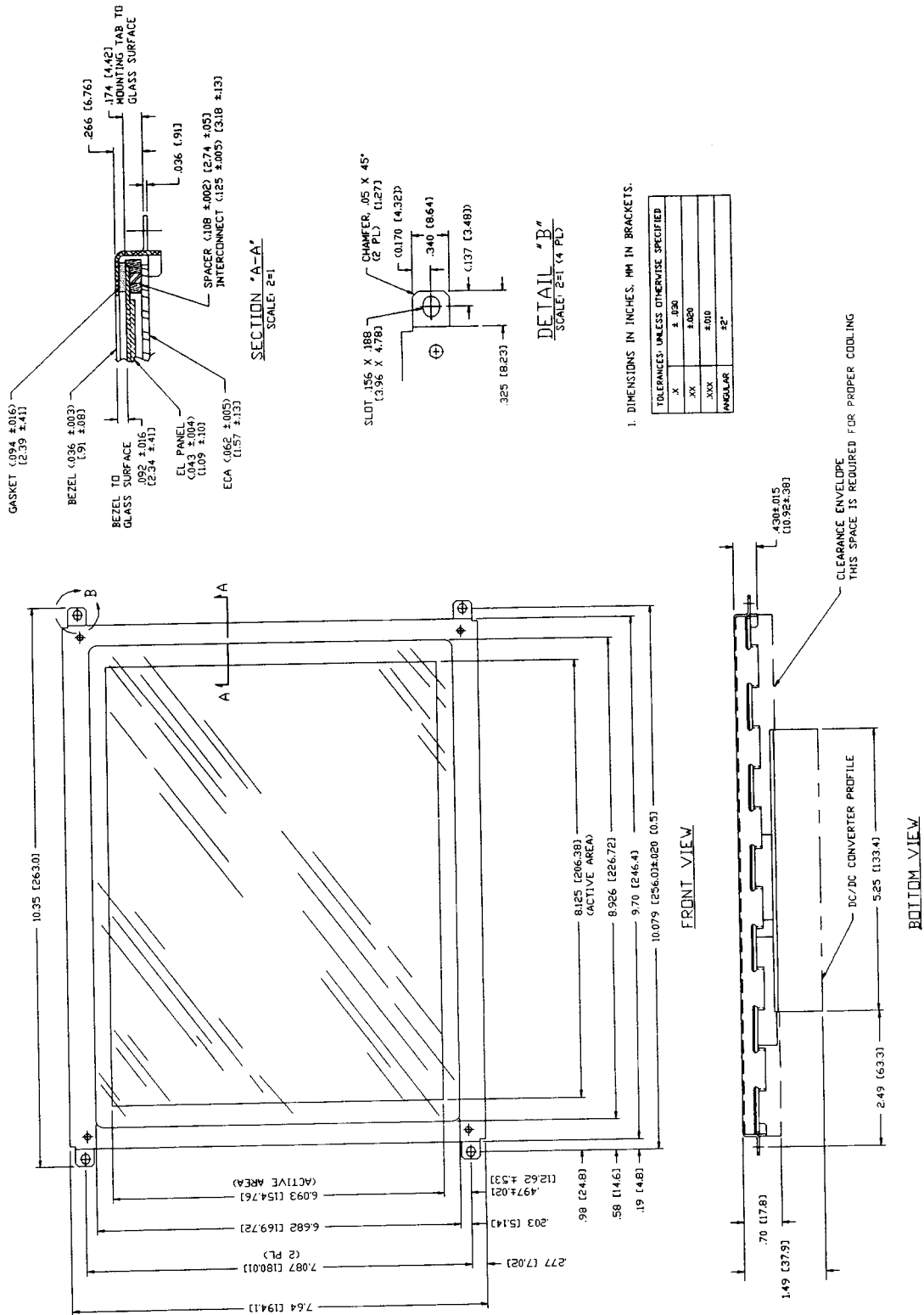

■ Display (rear view)

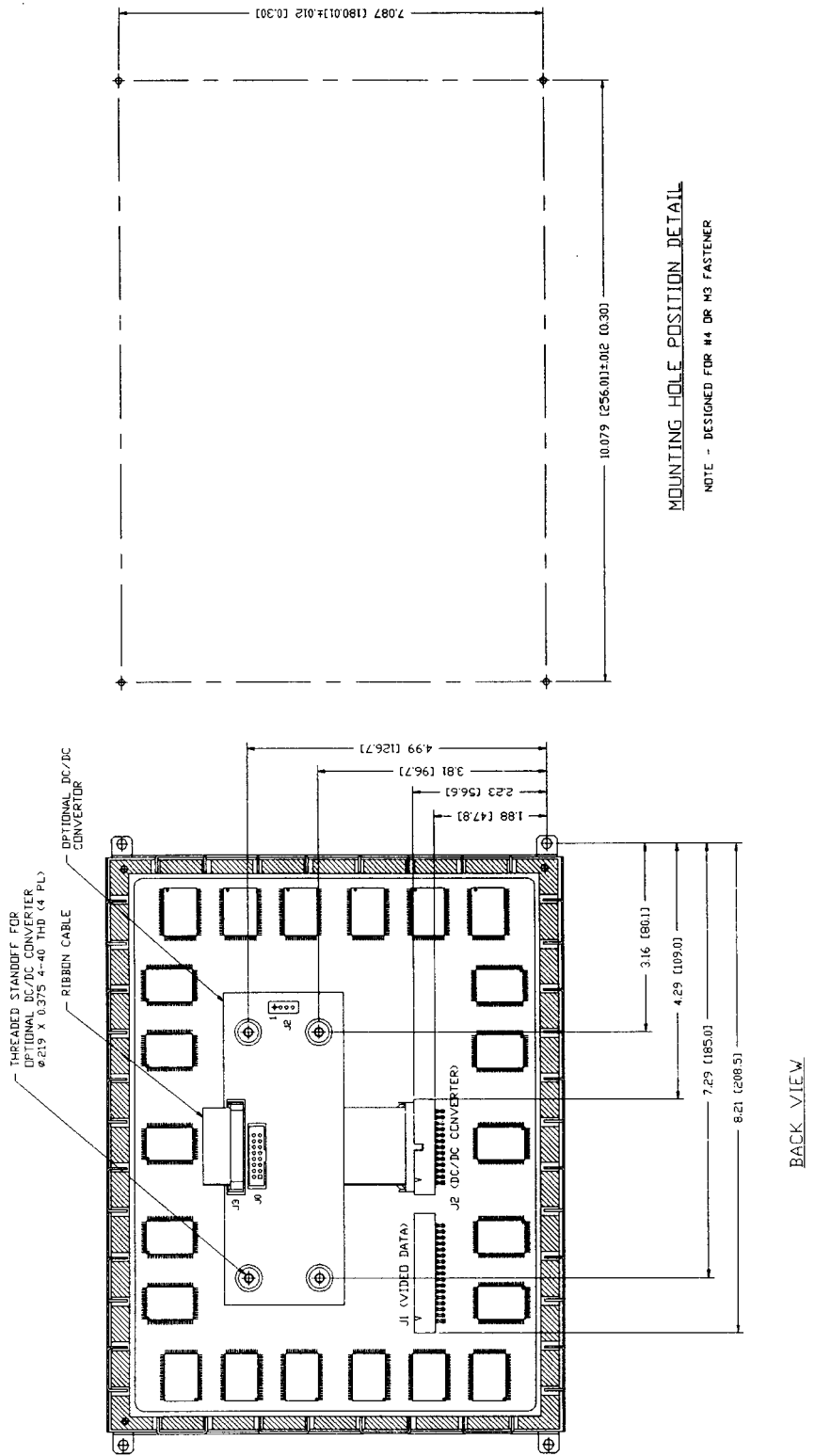

Note - Connector and threaded standoff locations are accurate to ± 0.090 (2.3)

Description of Warranty

This description is not the full warranty, and should not be construed as a substitute for the full warranty. A copy of the full warranty is available upon request.

Planar warrants that the goods it sells will be free of defects in materials and workmanship, and that these goods will substantially conform to the specifications furnished by Planar, and to any drawings or specifications furnished to the Seller by the Buyer if approved by the Seller. This warranty is effective only if Planar receives notice of such defect or nonconformance during the period of warranty, which begins the day of delivery.

The goods Planar sells are warranted for a period of one year unless otherwise agreed to by Planar and the Buyer. The Buyer must return the defective or nonconforming goods, upon request, to Planar not later than 30 days after Planar's receipt of notice of the alleged defect or non-compliance. Buyer shall prepay transportation charges, and Planar shall pay for return of the goods to the Buyer. No goods are to be returned to Planar without prior written permission.

The warranty does not apply in cases of improper or inadequate maintenance by the Buyer, unauthorized modification of the goods, operation of the goods outside their environmental specifications, neglect or abuse of the goods, or modification or integration with other goods not covered by a Planar warranty when such modification or integration increases the likelihood of damage of the goods.

Represented by:

North American sales contact
Planar Systems, Inc.
 1400 N.W. Compton Drive
 Beaverton, Oregon 97006 USA
Phone: (503) 690-1100
Fax: (503) 690-1493



European and Far East sales contact
Planar International Ltd.
 Olarinluoma 9
 P.O. Box 46
 FIN-02201 Espoo, Finland
Phone: 358 0 420 01
Fax: 358 0 422 143

Easy to Use

There are many options available which make Planar EL displays easy to use, easy to interface and easy to package. Examples of options which are typically available include RS232 Interface Adapter, IBM® XT/AT Interface Adapter, IBM® PS/2 Interface Adapter, Touch Bezels, Metallic Enclosures and AC Power Supplies. Call Planar for complete information and availability.

Support and Service

Planar is a U.S. company based in Beaverton, Oregon and Espoo, Finland with a world-wide sales distribution network. Full application engineering support and service are available to make the integration of Planar displays as simple and quick as possible for our customers.

RMA Procedure: For a Returned Material Authorization number, please contact Planar Systems, Inc. or Planar International's Customer Service Department with the model number(s) and original purchase order number(s). When returning goods for repair, please include a brief description of the problem, and mark the outside of the shipping container with the RMA number.