

ELM612DA 3A 36V PWM step down DC/DC converter

■ General description

ELM612DA is a of step-down switching regulator with PWM control, reference voltage source, oscillation circuit, error amplifier, internal PMOS, etc. ELM612DA provides low-ripple power, high efficiency, and excellent transient characteristics; PWM control circuit is able to vary the duty ratio linearly from 0 up to 100%. ELM612DA also contains error amplifier circuit as well as soft-start circuit that prevents overshoot at during startup. Internal enable function, over current protect function and short circuit protect function will reduce the operation frequency from 150kHz to 30kHz when overmuch current or short circuit occurs. Meanwhile, internal compensation block is able to minimize the quantity of required external component. With internal P-channel Power MOS, and externally connected coil, capacitor, and diode, ELM612DA is able to function as step-down switching regulator. By the small package of SOP-8, ELM612DA is capable of working as ideal power supply units for many devices while providing outstanding features such as low current consumption. Since this converter accommodates input voltage up to 36V, ELM612DA is also suitable for AC adapter applications.

■ Features

- Input voltage : 5.5V to 36V
- Output voltage : 0.8V to V_{in}
- Output current : 3.0A
- Duty ratio : 0% to 100%
- Constant frequency : Typ.150kHz
- Soft-start
- Thermal shutdown protection
- Short circuit protection
- Built-in internal P-channel MOS
- Package : SOP-8

■ Application

- PC motherboard
- LCD monitor
- Graphic card
- DVD, Blu-ray player
- Telecom equipment
- ADSL modem
- Printer and other peripheral equipment
- Microcomputer power supply
- Network power supply

■ Maximum absolute ratings

Parameter	Symbol	Limit	Unit
VIN power supply voltage	V_{in}	-0.3 to +40	V
Apply voltage to FB	V_{fb}	GND-0.3 to V_{in}	V
Apply voltage to EN	V_{en}	GND-0.3 to $V_{in}+0.3$	V
Apply voltage to SW	V_{sw}	GND-0.3 to $V_{in}+0.3$	V
Apply voltage to VC	V_c	$V_{in}-20$ to $V_{in}+0.3$	V
Power dissipation	P_d	300	mW
Operating temperature range	T_{op}	-40 to +85	°C
Storage temperature range	T_{stg}	-65 to +150	°C

Caution: Permanent damage to the device may occur when ratings above maximum absolute ones are used.

ELM612DA 3A 36V PWM step down DC/DC converter

■ Selection guide

ELM612DA-N

Symbol		
a	Package	D: SOP-8
b	Product version	A
c	Taping direction	N: Refer to PKG file

ELM612DA - N
 ↑↑ ↑
 a b c

* Taping direction is one way.

■ Pin configuration

SOP-8(TOP VIEW)

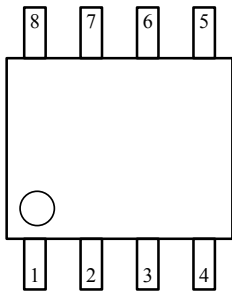

Pin No.	Pin name	Pin description
1	FB	Feedback(0.82V operation)
2	EN	Enable / Disable H: Normal operation mode.(Step-down operation) L: Shutdown mode.(All circuits deactivated)
3	VC	Add an external capacitor to VIN. The voltage is set to Vin -7V
4	VIN	IC power supply
5, 6	SW	Switch. Connect external inductor/diode to here. Minimize trace area at this pin to reduce EMI.
7, 8	GND	GND

■ Standard circuit

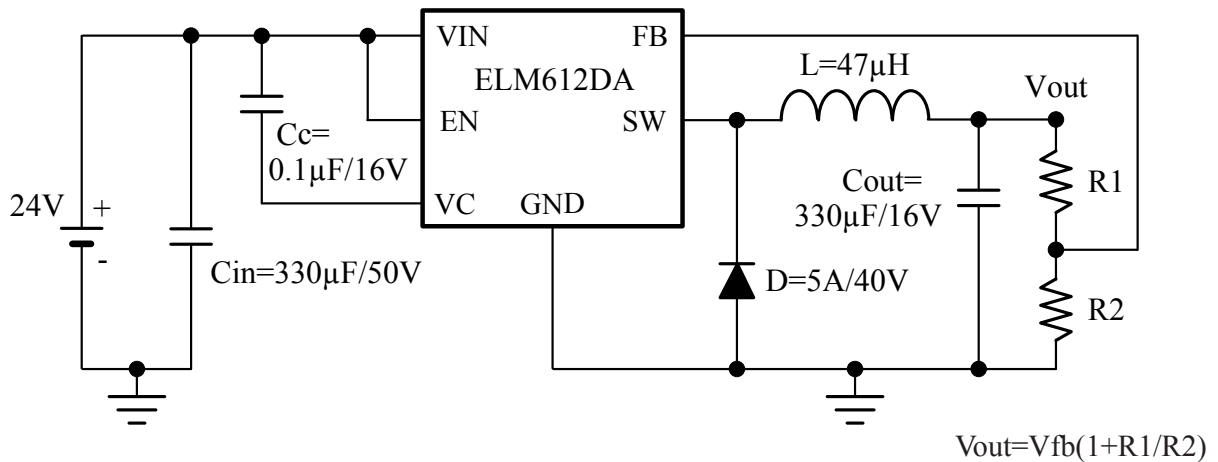

ELM612DA 3A 36V PWM step down DC/DC converter

■Block diagram

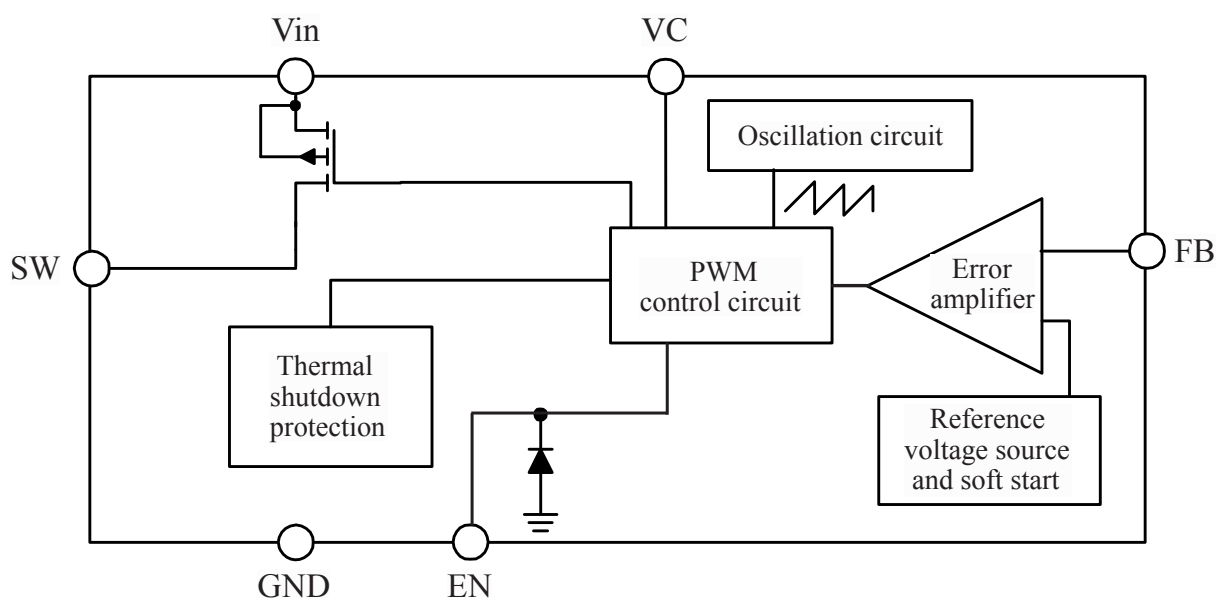

■Electrical characteristics

Vin=24V, Top=25°C, unless otherwise specified

Parameter	Symbol	Condition	Min.	Typ.	Max.	Unit
Input voltage	Vin		5.5		36.0	V
EN pin input voltage (*1)	Venh	Evaluate oscillation at SW pin	2.0			V
	Venl	Evaluate oscillation stop at SW pin	-		0.8	
Feedback voltage	Vfb	Iout=0.1A	0.803	0.820	0.836	V
Feedback bias current	Ifb	Iout=0.1A	-	0.1	0.5	μA
Current limit	Icl		2.0			A
Quiescent current (switch off)	Ignd	EN ≥ Ven_h, Vfb=1V		1	2	mA
Current consumption during power off	Ignd_off	EN ≤ Ven_l		1	10	μA
Voltage clamp	Vc	No load	Vin-6	Vin-7	Vin-8	V
Oscillation frequency	Fosc		120	150	180	kHz
Frequency of current limit or short circuit protect	Foscl		20	30	40	kHz
Line regulation	$\frac{\Delta V_{out}}{V_{out}}$	Vin=12V to 36V, Iout=0.2A		1	2	%
Load regulation	$\frac{\Delta V_{out}}{V_{out}}$	Iout=0.1 to 1.3A		0.2	0.5	%
Internal MOSFET Rds(on)	Rds(on)	Vfb=0V, Iout=1A		80	100	mΩ
Efficiency	η	Vin=24V, Vout=5V, Iout=3.0A		87		%
(*1) : Rise time and fall time of the EN pin use under the following conditions, please.						
EN pin rise time & fall time	tr, tf	Ven=Venl to VenH			50	μS

ELM612DA 3A 36V PWM step down DC/DC converter

■Application notes

PWM Control

ELM612DA is DC/DC converter which consists pulse-width modulation (PWM) system. In converters of ELM612DA, the pulse width varies according to the load current, within the range from 0 to 100%. The ripple voltage produced by switching can easily be removed through the filter since switching frequency remains constant; ELM612DA is capable of providing low-ripple power within broad ranges of input voltage and load current.

■Test circuits

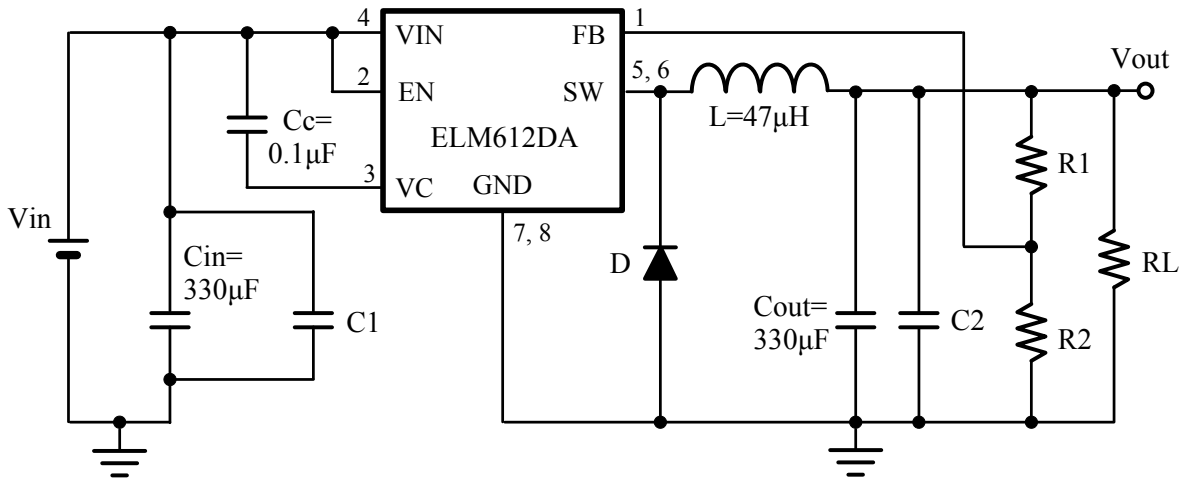

■Marking

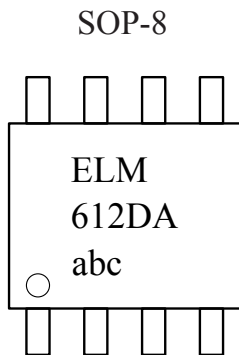

Mark	Content
ELM612DA	Product name
abc	Assembly lot No.: 000 to 999 repeated

ELM612DA 3A 36V PWM step down DC/DC converter

■ Typical characteristics

- $V_{out}=3.3V$:
 $C_{in}=330\mu F$, $C_{out}=330\mu F$, $R1=4k\Omega$, $R2=1.3k\Omega$, $C1=0.1\mu F$, $C2=0.1\mu F$, $L=47\mu H$,
 $D=5A/40V$, $T_{op}=25^{\circ}C$

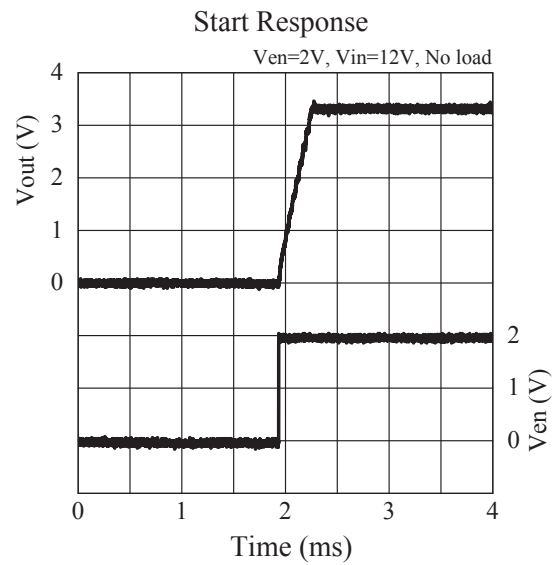
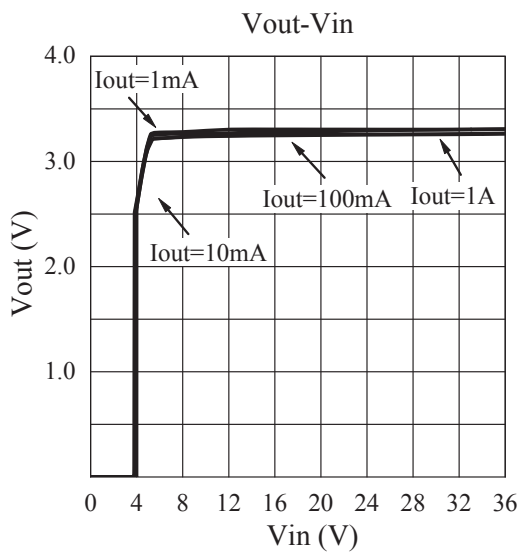
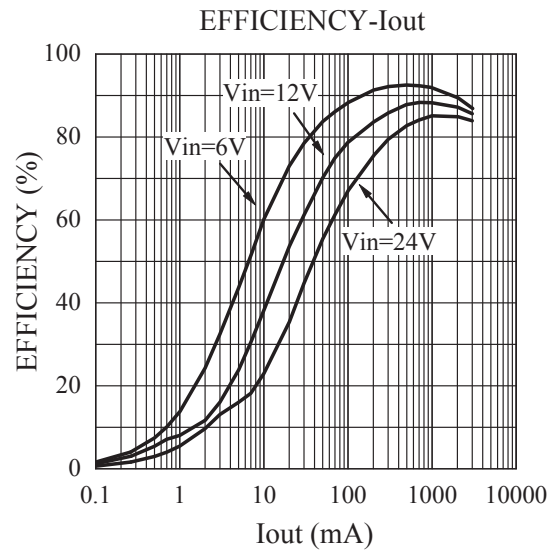
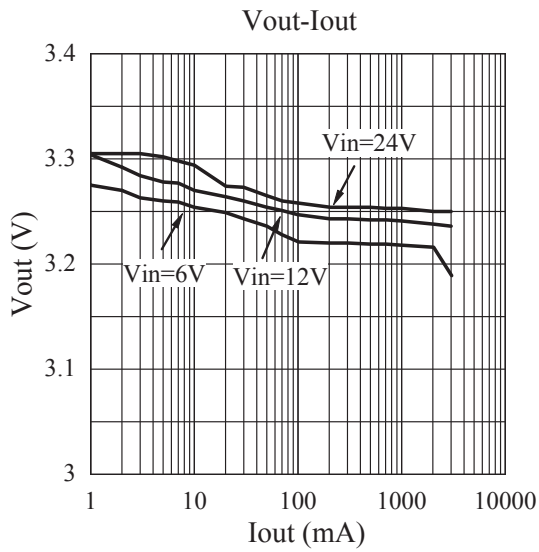

ELM612DA 3A 36V PWM step down DC/DC converter

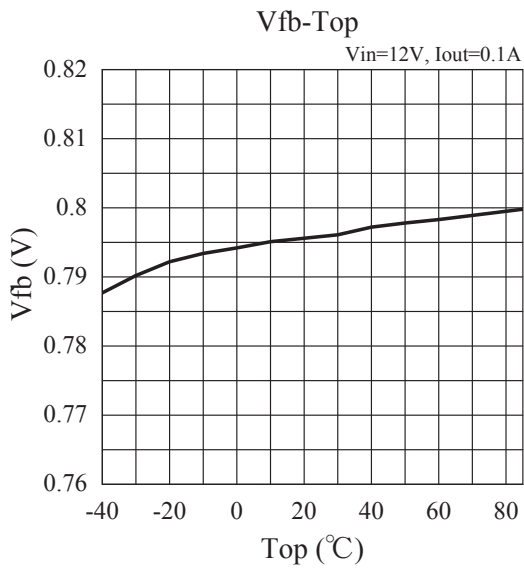
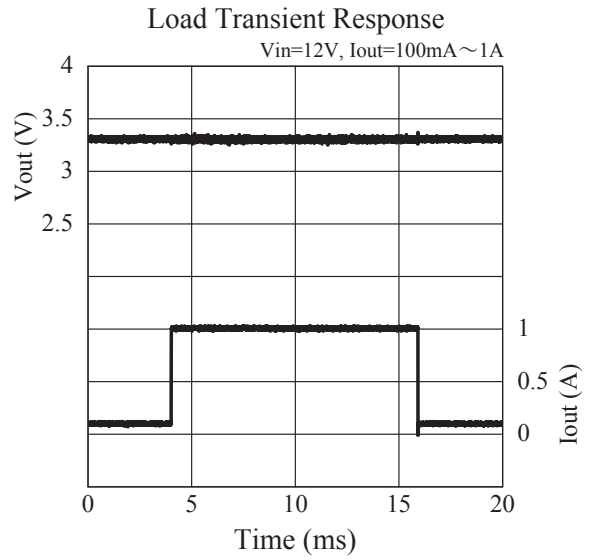
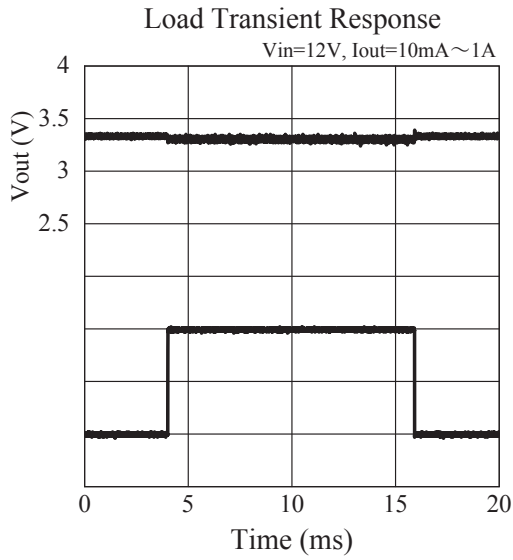

ELM612DA 3A 36V PWM step down DC/DC converter

- $V_{out}=5.0V$:
 $C_{in}=330\mu F$, $C_{out}=330\mu F$, $R1=6.8k\Omega$, $R2=1.3k\Omega$, $C1=0.1\mu F$, $C2=0.1\mu F$, $L=47\mu H$,
 $D=5A/40V$, $T_{op}=25^{\circ}C$

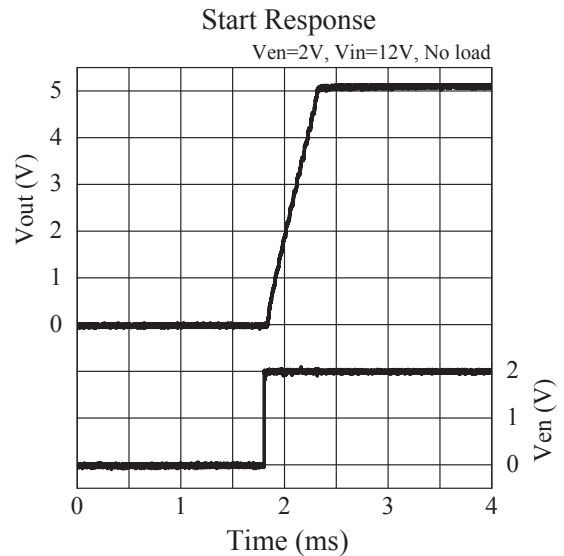
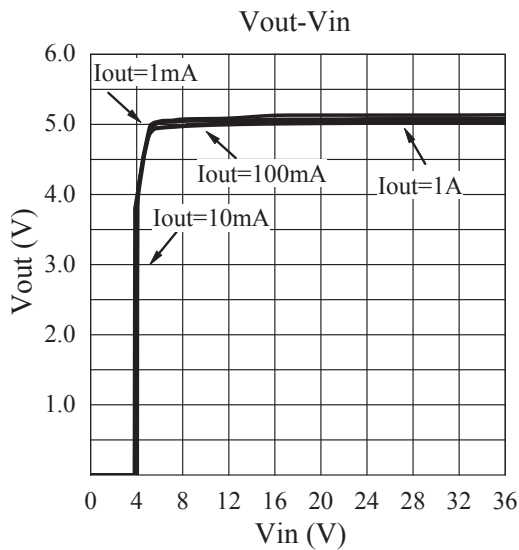
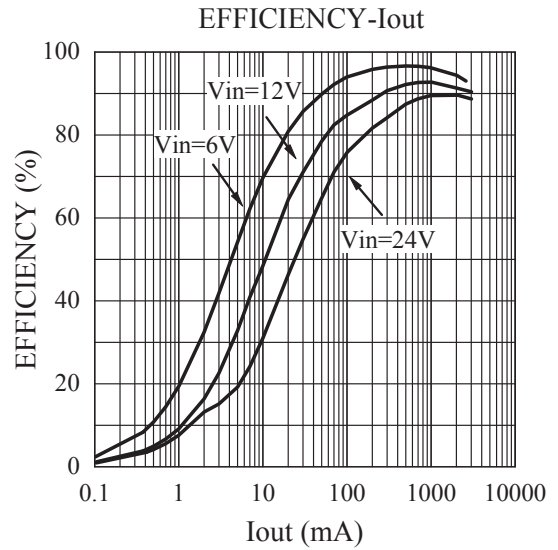
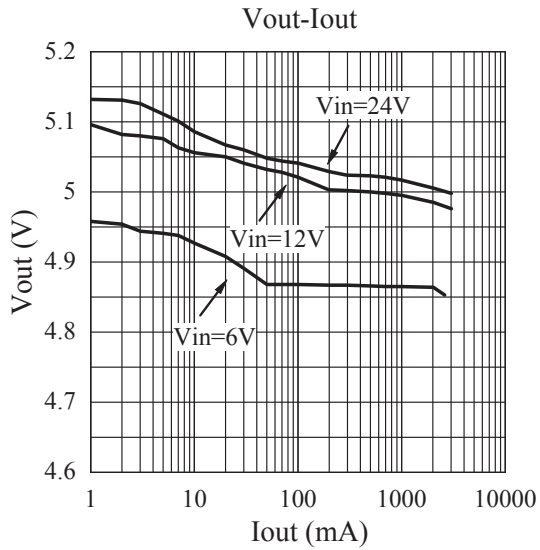

ELM612DA 3A 36V PWM step down DC/DC converter

