



ELM627

RS232 Break Detector

Description

The ELM627 is a complete circuit for detecting break signals on RS232 lines, in an 8 pin package. This is useful for remotely resetting circuits through a serial link. For convenience, this circuit also generates an output pulse on power-up.

The timing threshold for break signal detection is user selectable, allowing the circuit to respond to transmitted null characters, <ctrl>@, at various baud rates. This provides a convenient means for the remote triggering of this circuit by simply shifting to a lower baud rate and sending a null byte.

Two complementary high current outputs are provided by the ELM627, so that further buffering is not usually required. The output signal can be selected to be either a continuous one (following the TxD input line) or else a 100ms pulse output.

No external components are required for circuit operation other than possibly a current limiting resistor, as all timing references are generated internally.

Applications

- Remote resetting of RS232 devices
- Edge triggered one-shot circuits
- Digitally controlled sequencing schemes
- Watchdog type signal monitors

Features

- Low power CMOS design - typically 1mA at 5V
- No external timing elements required
- Complementary outputs
- Digitally controlled threshold timing
- Selectable output duration
- High current drive outputs - up to 25 mA

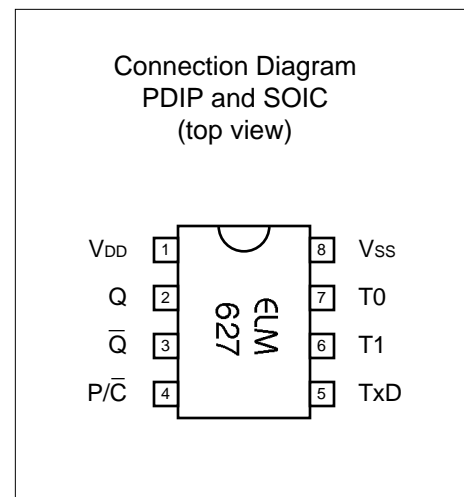

Block Diagram

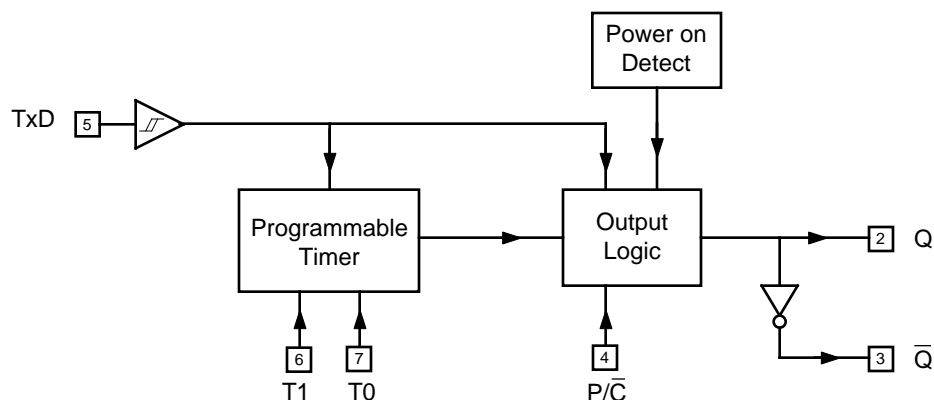



Pin Descriptions

VDD (pin 1)

This pin is the positive supply pin, and should always be the most positive point in the circuit. Internal circuitry connected to this pin is used to provide power on reset of the microprocessor, so an external reset signal is not required. Refer to the Electrical Characteristics section for further information.

Q (pin 2)

This signal is driven to a logical high level when a break signal is detected, and during powerup.

Q̄ (pin 3)

This output signal is normally held at a high level, and is driven low when a break signal is detected, as well as immediately after powerup.

P/C̄ (pin 4)

This is the pulse/continuous control input pin, used to modify the behavior of the circuit output. If at a logic high when a break signal is detected, the output will consist of a single 100ms pulse.

Otherwise, the output will remain active continuously until pin 5 returns to a logical low level. The output duration will always be a minimum of 10ms, and is 100ms on powerup.

TxD (pin 5)

This is the monitored signal input, usually connected directly to the RS232 Transmit Data line through a suitable current limiting resistor. This input employs Schmitt trigger logic so that input waveshaping circuitry is not normally required.

T1 (pin 6) and T0 (pin 7)

These are the threshold setting inputs. Logic levels on these pins at the rising edge of TxD are used to determine the required minimum duration of the break signal, as shown in Table 1 below.

Vss (pin 8)

Circuit common is connected to this pin. This is the most negative point in the circuit.

| Threshold Setting | | Min Break Signal (msec) | Baud rate, '00' character sent | |
|-------------------|----|-------------------------|--------------------------------|------------|
| T1 | T0 | | will trigger at | but not at |
| L | L | 5.0 | 1200 | 2400 |
| L | H | 11 | 600 | 1200 |
| H | L | 22 | 300 | 600 |
| H | H | 120 | - | 110 |

Table 1. Threshold Settings

Ordering Information

These integrated circuits are available in either the 300 mil plastic DIP format, or in the 200 mil SOIC surface mount type of package. To order, add the appropriate suffix to the part number:

300 mil Plastic DIP..... ELM627P

200 mil SOIC..... ELM627SM

All rights reserved. Copyright ©1998 Elm Electronics.

Every effort is made to verify the accuracy of information provided in this document, but no representation or warranty can be given and no liability assumed by Elm Electronics with respect to the accuracy and/or use of any products or information described in this document. Elm Electronics will not be responsible for any patent infringements arising from the use of these products or information, and does not authorize or warrant the use of any Elm Electronics product in life support devices and/or systems. Elm Electronics reserves the right to make changes to the device(s) described in this document in order to improve reliability, function, or design.



Absolute Maximum Ratings

Storage Temperature..... -65°C to +150°C
 Ambient Temperature with
 Power Applied..... -40°C to +85°C
 Voltage on V_{DD} with respect to V_{SS}..... 0 to +7.5V
 Voltage on any other pin with
 respect to V_{SS}..... -0.6V to (V_{DD} + 0.6V)

Note:
 Stresses beyond those listed here will likely damage the device. These values are given as a design guideline only. The ability to operate to these levels is neither inferred nor recommended.

Electrical Characteristics

All values are for operation at 25°C and a 5V supply, unless otherwise noted. For further information, refer to note 1 below.

| Characteristic | Minimum | Typical | Maximum | Units | Conditions |
|---|-----------------------|---------|----------------------|-------|--------------------------|
| Supply Voltage, V _{DD} | 4.5 | 5.0 | 5.5 | V | |
| V _{DD} rate of rise | 0.05 | | | V/ms | see note 2 |
| Average Supply Current, I _{DD} | | 1.0 | 2.4 | mA | see note 3 |
| Input low voltage | V _{SS} | | 0.15 V _{DD} | V | |
| Input high voltage | 0.85 V _{DD} | | V _{DD} | V | |
| Output low voltage | | | 0.6 | V | Current (sink) = 8.7mA |
| Output high voltage | V _{DD} - 0.7 | | | V | Current (source) = 5.4mA |
| Output Pulse Width | 95 | 100 | 105 | msec | see notes 4 and 5 |
| Maximum Timing Error | | 5 | | % | see note 4 |
| Input Current | -0.5 | | +0.5 | mA | see note 6 |

Notes:

1. This integrated circuit is produced with a Microchip Technology Inc.'s PIC12C5XX as the core embedded microcontroller. For further device specifications, and possibly clarification of those given, please refer to the appropriate Microchip documentation.
2. This spec must be met in order to ensure that a correct power on reset occurs. It is quite easily achieved using most common types of supplies, but may be violated if one uses a slowly varying supply voltage, as may be obtained through direct connection to solar cells, or some charge pump circuits.
3. Device only. Does not include any LED or drive currents.
4. Pulse timing is generated internally, and is affected by both temperature and supply voltage. Although the limits cannot be absolutely guaranteed, these are generally the widest variation that would normally be encountered.
5. This pulse is also generated immediately after circuit powerup.
6. This specification represents current flowing through the protection diodes when applying large voltages to the TxD input (pin 5) through a current limiting resistance. Currents quoted are the maximum continuous.

Example Application

Figure 1 shows the ELM627 installed in a remotely connected, RS232 linked device. This is typical of many connections used today - a 9600 baud serial connection is made between a PC and a remote device. Serial data is continually sent between the two devices, but control of the remote system is by software only.

It is often quite desirable in such a case to be able to reset the remote system to a known state under software control. This can be either at startup, or if the remote system fails to respond to signals for any reason.

The circuit shown below represents all that is typically required to provide remote as well as power on resetting capability. The ELM627 continuously monitors the transmit data line for a high level (3-25V) through the 100K current limiting resistor. The second 100K resistor is only used to provide a pull-down to V_{ss}, should the data link become open circuited. Depending on what other devices are connected, this resistor may not be required.

Pins 6 and 7 are shown shorted to V_{ss}, setting the circuit to trigger on any high level that exceeds 5msec in duration. This allows for triggering of the circuit on a null character ('00') at 1200 baud, easily accomplished with most systems.

The final connection to note is that the pulse/continuous control (pin 4) has been tied to a high level so that the generated reset pulse will always be of 100msec duration. This pulse width isn't normally necessary for the circuitry, but may be desirable if one wants to connect an LED or a buzzer to the circuit for feedback.

Several variations on this type of circuit are possible. By noting that the 'reset' output can be used for other control purposes, and possibly adding a toggle type latch, the circuit can be expanded to remotely turn on and off devices, leading to several automation possibilities...

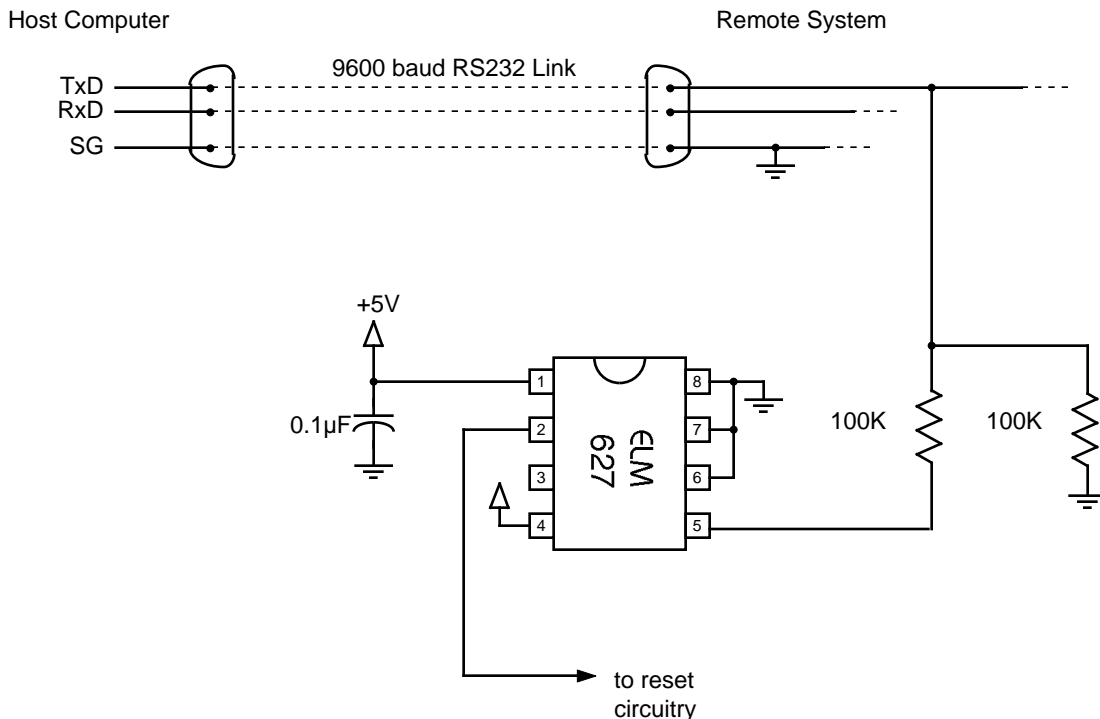

Figure 1. Remote Reset Control