

FEATURES

High Output Power: P_{1dB}=36.0dBm (Typ.)
 High Gain: G_{1dB}=10.5dB (Typ.)
 High PAE: η_{add}=35% (Typ.)
 Broad Band: 7.1 to 7.9GHz
 Internally matched
 Plastic Package for SMT applications

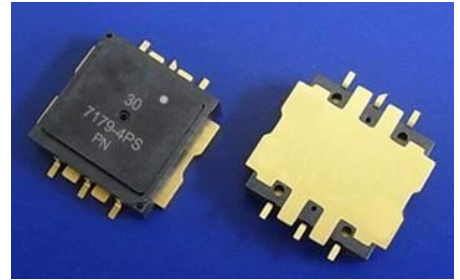

DESCRIPTION

The ELM7179-4PS is a power GaAs FET that is internally matched for standard communication bands to provide optimum power and gain.

ABSOLUTE MAXIMUM RATING (Case Temperature T_c=25 deg.C)

Item	Symbol	Rating	Unit
Drain-Source Voltage	V _{DS}	15	V
Gate-Source Voltage	V _{GS}	-5	V
Total Power Dissipation	P _T	27.3	W
Storage Temperature	T _{STG}	-40 to +125	deg.C
Channel Temperature	T _{CH}	175	deg.C

RECOMMENDED OPERATING CONDITION (Case Temperature T_c=25 deg.C)

Item	Symbol	Condition	Limit	Unit
DC Input Voltage	V _{DS}		<10	V
Forward Gate Current	I _{GF}	R _G =100 ohm	<+16	mA
Reverse Gate Current	I _{GR}	R _G =100 ohm	>-2.2	mA
Channel Temperature	T _{CH}		155	deg.C

ELECTRICAL CHARACTERISTICS (Case Temperature T_c=25 deg.C)

Item	Symbol	Condition	Limit			Unit
			Min.	Typ.	Max.	
Drain Current	I _{DSS}	V _{DS} =5V, V _{GS} =0V	-	1700	2600	mA
Trans conductance	gm	V _{DS} =5V, I _{DS} =1100mA	-	1700	-	mS
Pinch-off Voltage	V _P	V _{DS} =5V, I _{DS} =85mA	-0.5	-1.5	-3.0	V
Gate-Source Breakdown Voltage	V _{GSO}	I _{GS} =85uA	-5.0	-	-	V
Output Power at 1dB G.C.P.	P _{1dB}	V _{DS} =10V I _{DS(DC)} =0.65I _{DSS} (typ.) f=7.1 to 7.9 GHz	35.0	36.0	-	dBm
Power Gain at 1dB G.C.P.	G _{1dB}		9.0	10.5	-	dB
Drain Current	I _{dsr}		-	1100	1300	mA
Power Added Efficiency	η _{add}		-	35	-	%
Gain Flatness	ΔG		-	-	1.2	dB
3 rd Order Inter Modulation Distortion	IM ₃	f=7.9GHz Δf=10MHz, 2-tone Test P _{out} =25.5dBm (S.C.L.)	-40	-43	-	dBc
R _{th}	R _{th}	Channel to Case	-	4.5	5.5	deg.C/W
ΔT _{ch}	ΔT _{ch}	10V x I _{dsr} x R _{th}	-	-	71.5	deg.C

CASE STYLE: I2C

ESD	Class 3 A	4000 to 8000V
MSL	2A	4 weeks after open the package
RoHS COMPLIANCE	Yes	

Ordering Information

Model Type	MOQ	MOU	Packing Style
ELM7179-4PS	15pcs	15pcs	15pcs Tray
ELM7179-4PST	500pcs	500pcs	24mm width Tape (500pcs/Reel)

*MOQ stands for Minimum Order Quantity.

*MOU stands for Minimum Order Unit size.

Note

- This device will not be delivered with test data but tested pass/fail 100% against DC and RF specifications.
- NO liquid cleaning process is suitable for this device. (including de-ionized water or solvent)

● RF Characteristics

Power Derating Curve

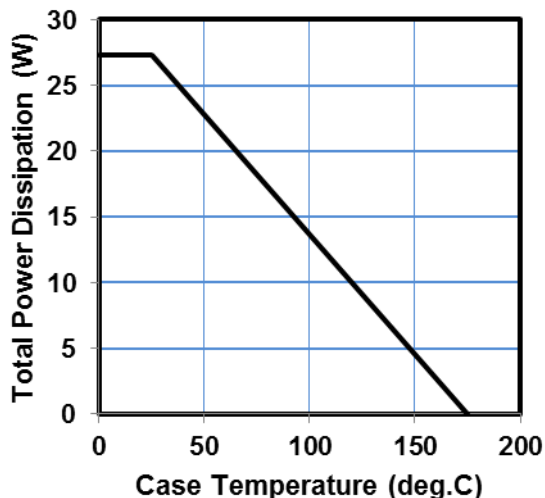

Input Power vs. Output Power, Power Added Efficiency

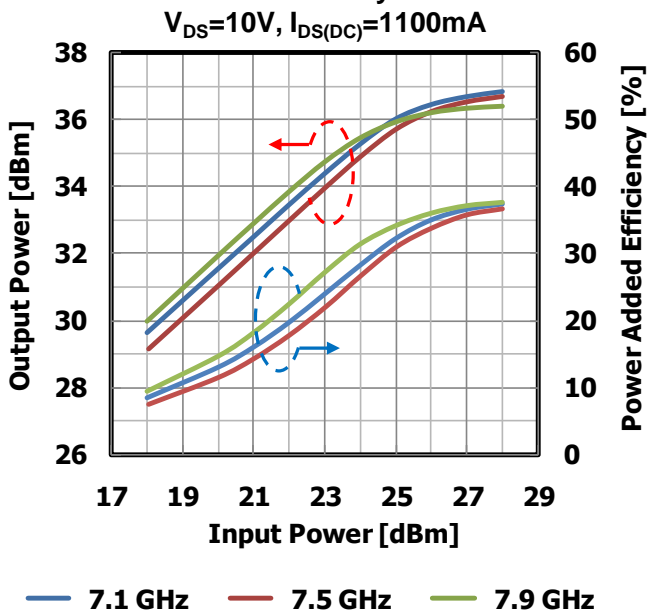

Output Power vs. Frequency

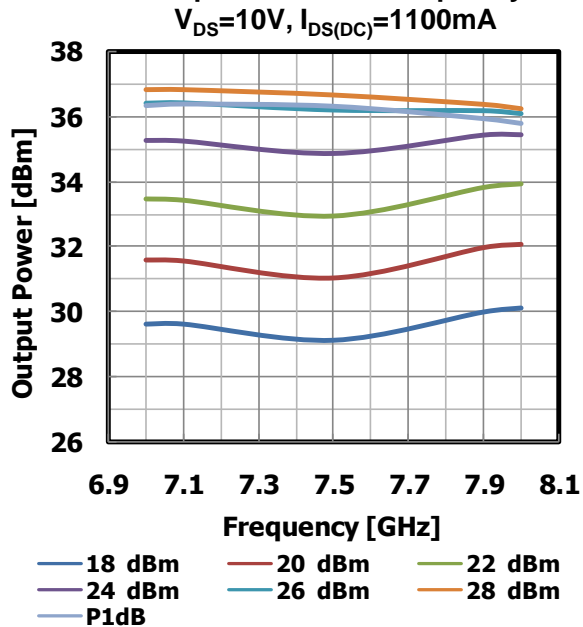

IMD vs. Output Power

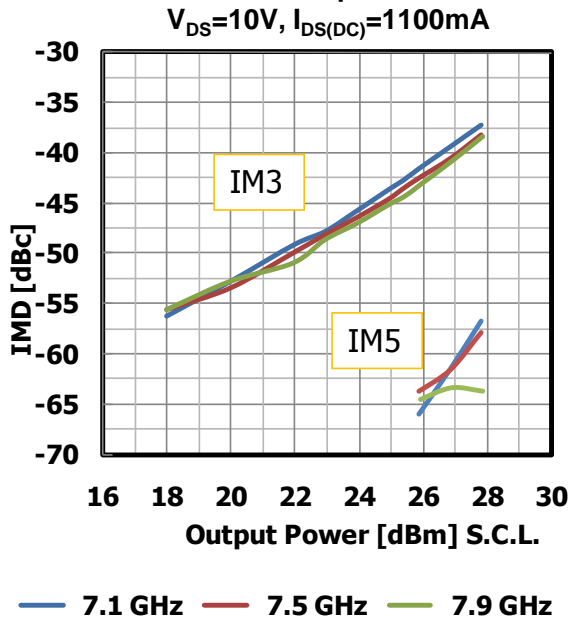

Input Power vs. Output Power, Power Added Efficiency by Drain Voltage
 $I_{DS(DC)}=1100\text{mA}$ @7.1GHz

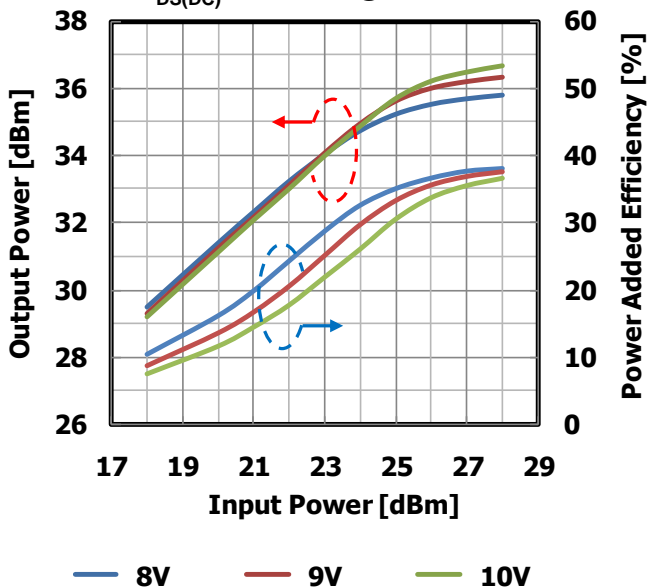

Input Power vs. Output Power, Power Added Efficiency by Drain Voltage
 $I_{DS(DC)}=1100\text{mA}$ @7.5GHz

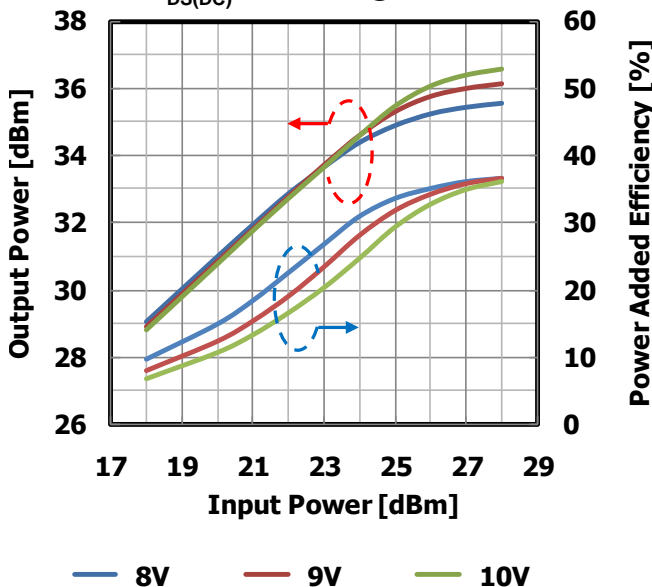

Input Power vs. Output Power, Power Added Efficiency by Drain Voltage
 $I_{DS(DC)}=1100\text{mA}$ @7.9GHz

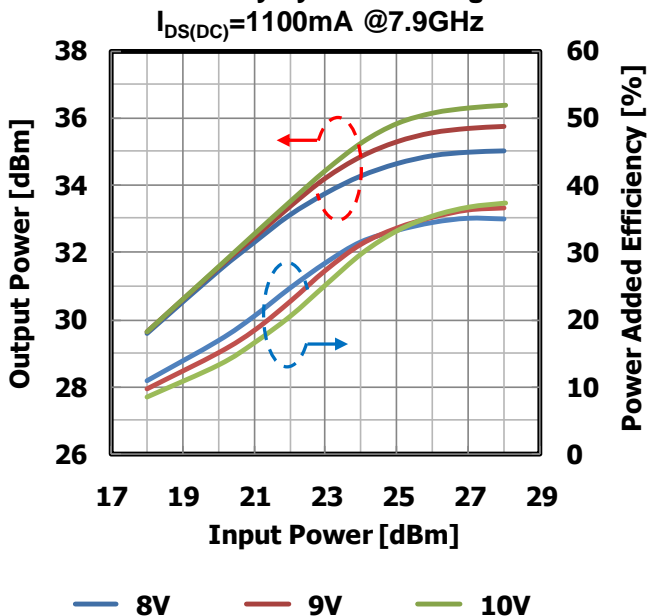

Input Power vs. Output Power, Power Added Efficiency by Quiescent Drain Current
 $V_{DS}=10V$ @7.1GHz

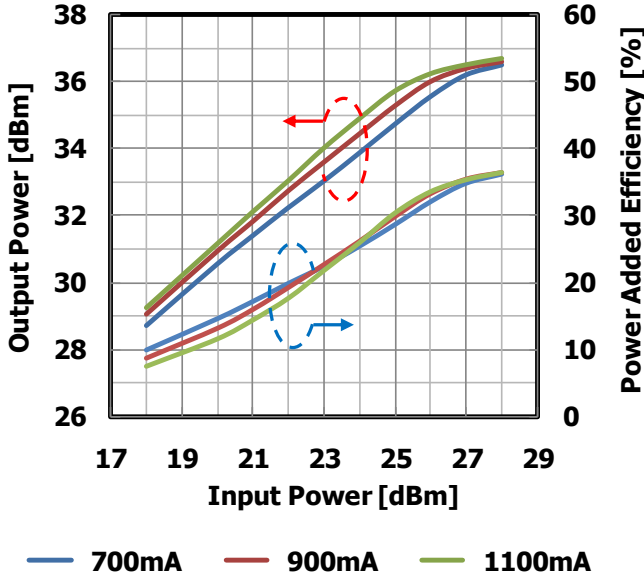

Input Power vs. Output Power, Power Added Efficiency by Quiescent Drain Current
 $V_{DS}=10V$ @7.5GHz

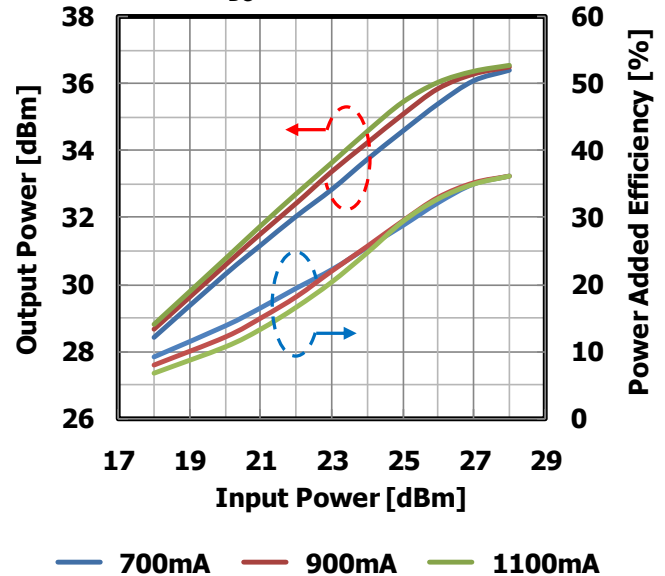

Input Power vs. Output Power, Power Added Efficiency by Quiescent Drain Current
 $V_{DS}=10V$ @7.9GHz

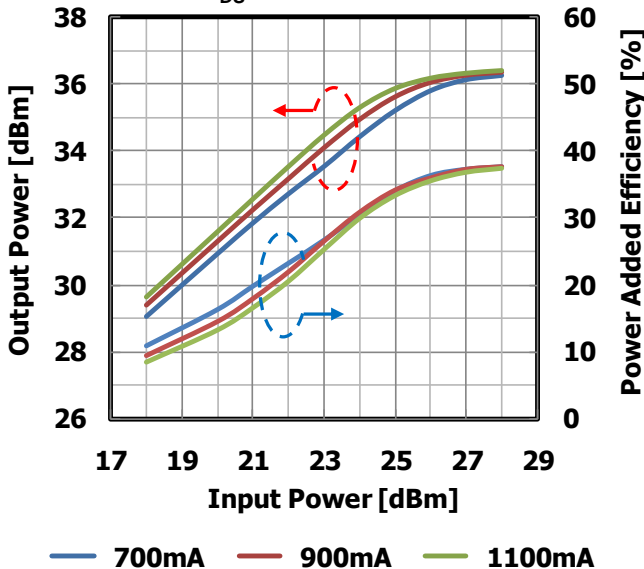

Input Power vs. Output Power, Power Added Efficiency by Temperature

$V_{DS}=10V$ @7.1GHz

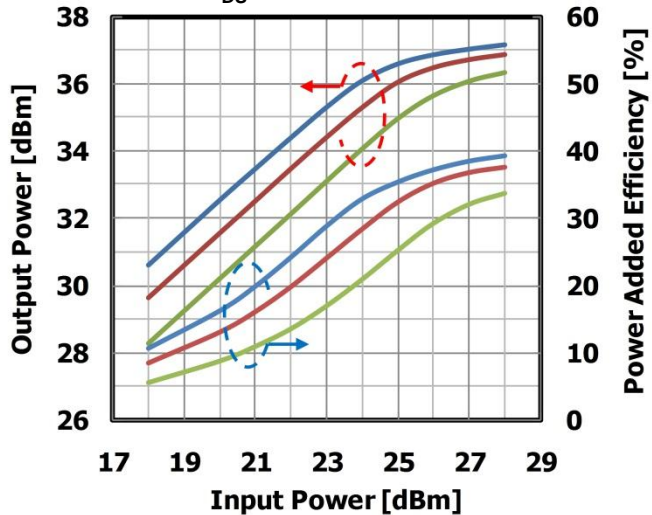

— Tc=-40deg.C — Tc=20deg.C
— Tc=80deg.C

Input Power vs. Output Power, Power Added Efficiency by Temperature

$V_{DS}=10V$ @7.5GHz

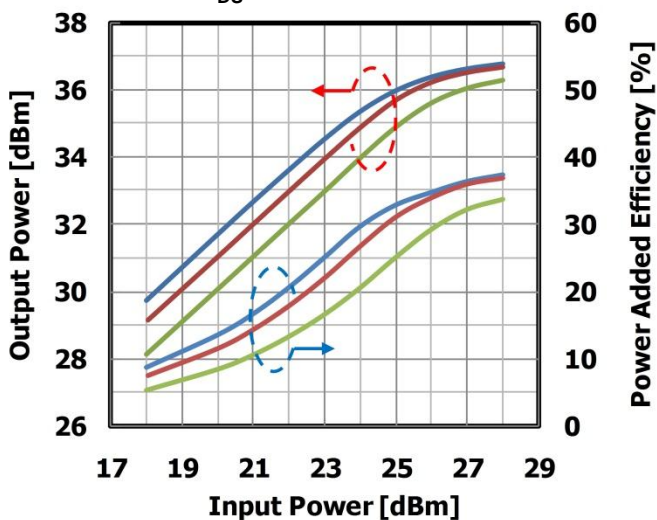

— Tc=-40deg.C — Tc=20deg.C
— Tc=80deg.C

Input Power vs. Output Power, Power Added Efficiency by Temperature

$V_{DS}=10V$ @7.9GHz

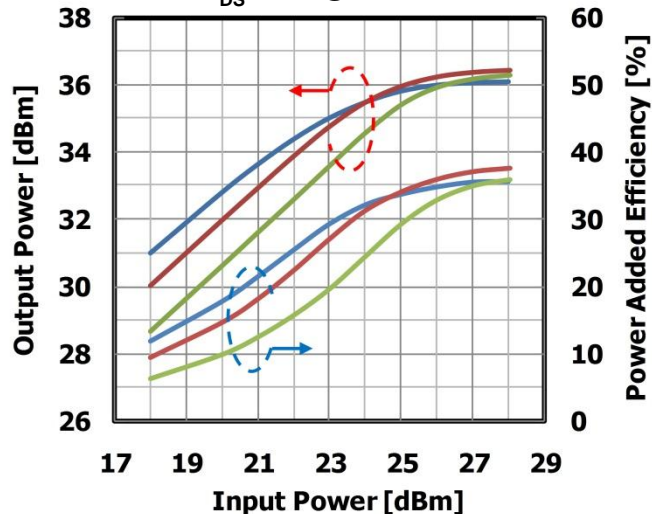

— Tc=-40deg.C — Tc=20deg.C
— Tc=80deg.C

IMD Performance vs. Output Power by Drain Voltage

$I_{DS(DC)}=1100\text{mA}$ @7.1GHz

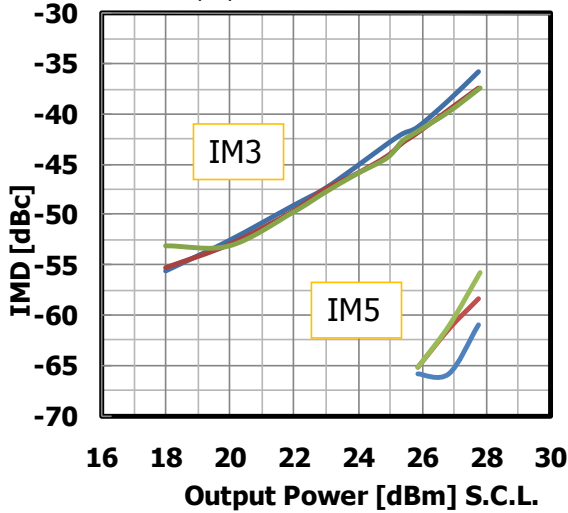

8V 9V 10V

IMD Performance vs. Output Power by Drain Voltage

$I_{DS(DC)}=1100\text{mA}$ @7.5GHz

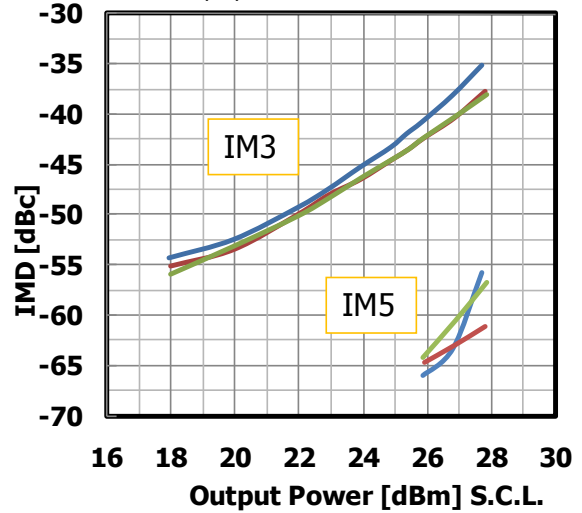

8V 9V 10V

IMD Performance vs. Output Power by Drain Voltage

$I_{DS(DC)}=1100\text{mA}$ @7.9GHz

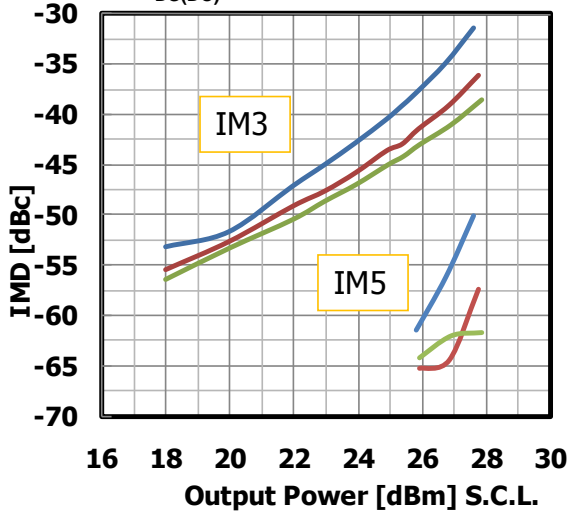

8V 9V 10V

IMD Performance vs. Output Power by Quiescent Drain Current
 $V_{DS}=10V$ @7.1GHz

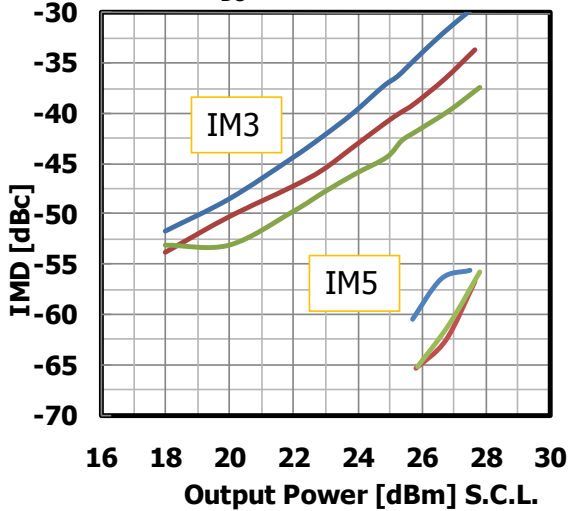

IMD Performance vs. Output Power by Quiescent Drain Current
 $V_{DS}=10V$ @7.5GHz

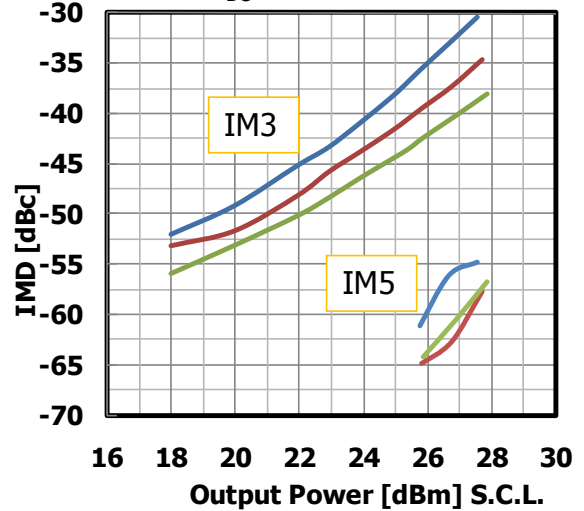

— 700mA — 900mA — 1100mA

— 700mA — 900mA — 1100mA

IMD Performance vs. Output Power by Quiescent Drain Current
 $V_{DS}=10V$ @7.9GHz

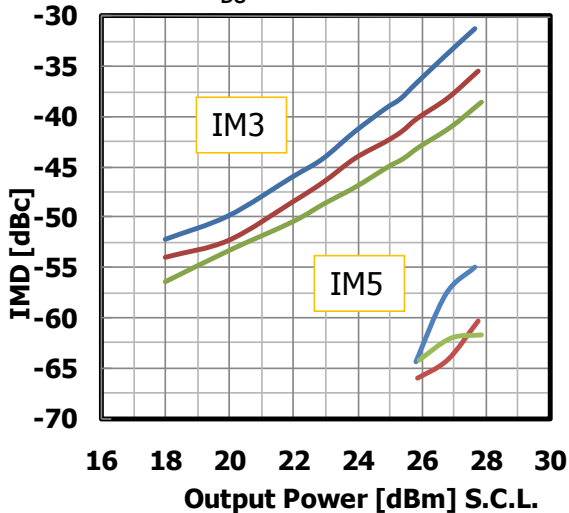

— 700mA — 900mA — 1100mA

IMD Performance vs. Output Power by Temperature
 $V_{DS}=10V$ @7.1GHz

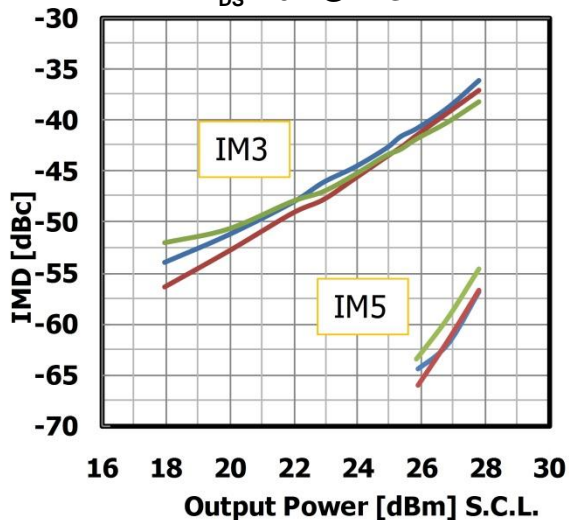

IMD Performance vs. Output Power by Temperature
 $V_{DS}=10V$ @7.5GHz

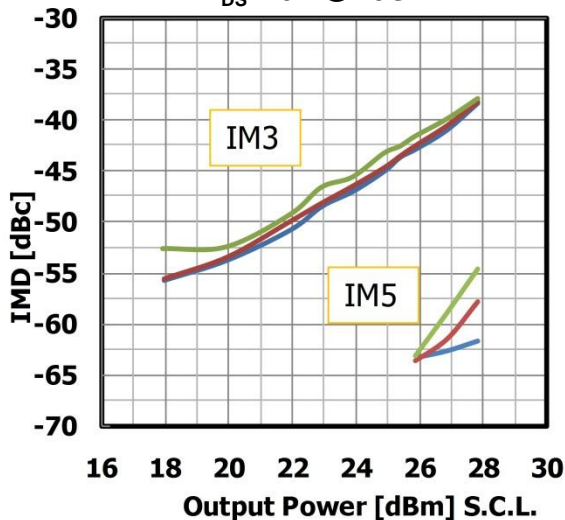

IMD Performance vs. Output Power by Temperature
 $V_{DS}=10V$ @7.9GHz

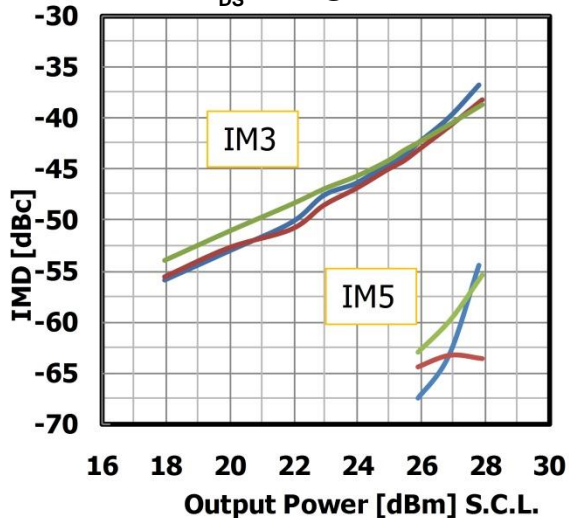

● S-Parameter

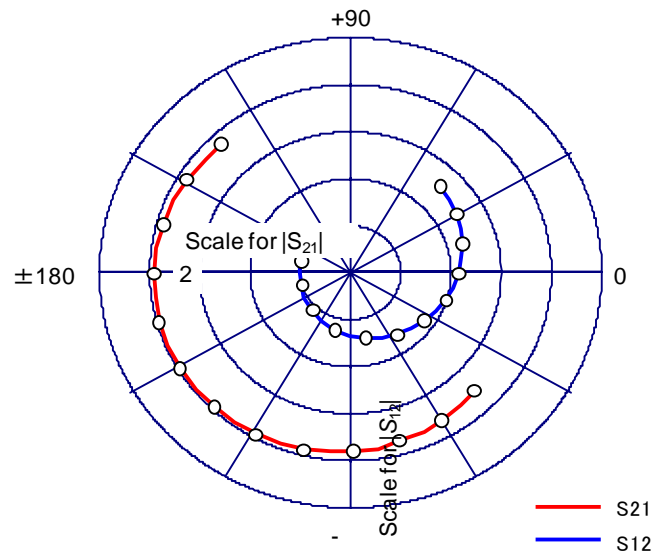
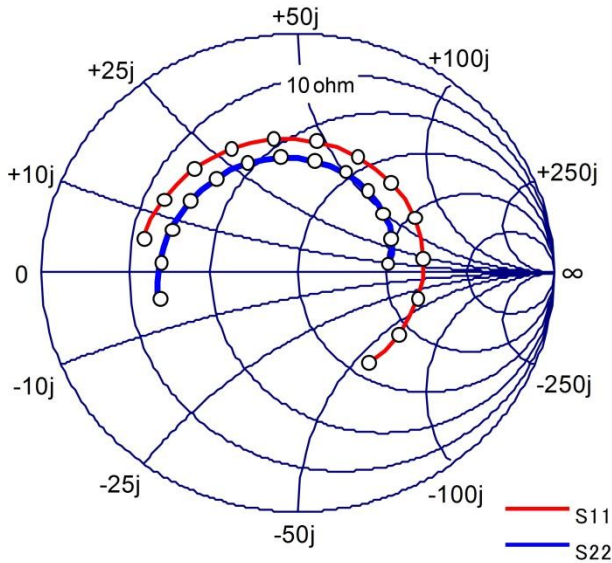

Frequency (MHz)	S11		S21		S12		S22	
	MAG	ANG	MAG	ANG	MAG	ANG	MAG	ANG
6900	0.689	173.1	3.012	-36.9	0.043	54.0	0.593	-168.4
7000	0.678	162.1	3.041	-49.1	0.040	41.5	0.592	179.9
7100	0.662	151.1	3.081	-60.8	0.038	29.3	0.597	169.4
7200	0.644	140.3	3.176	-72.3	0.035	16.3	0.597	159.5
7300	0.621	129.4	3.316	-84.2	0.033	2.5	0.596	150.1
7400	0.589	117.5	3.448	-96.5	0.030	-13.4	0.589	140.3
7500	0.552	104.0	3.614	-109.7	0.028	-31.1	0.575	130.7
7600	0.506	87.9	3.820	-123.9	0.027	-53.2	0.553	120.0
7700	0.450	68.4	4.038	-139.0	0.025	-80.7	0.519	108.4
7800	0.389	43.5	4.204	-155.2	0.023	-112.7	0.466	96.6
7900	0.344	11.5	4.311	-173.0	0.022	-145.5	0.398	83.2
8000	0.341	-24.7	4.336	168.5	0.023	-177.0	0.314	67.5
8100	0.380	-58.8	4.212	149.9	0.026	152.6	0.217	50.4

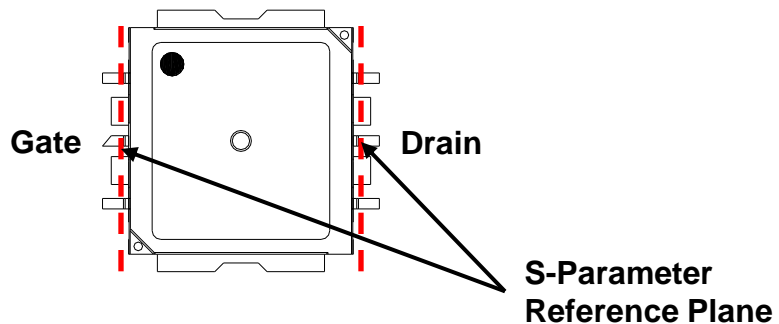

● Package Outline

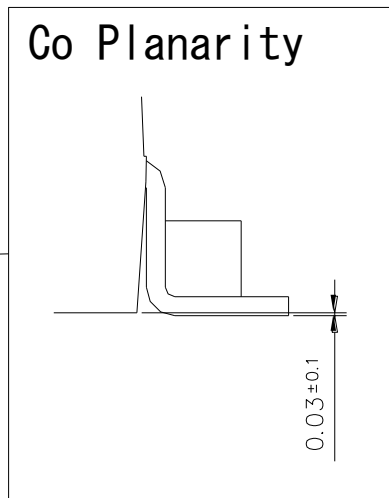
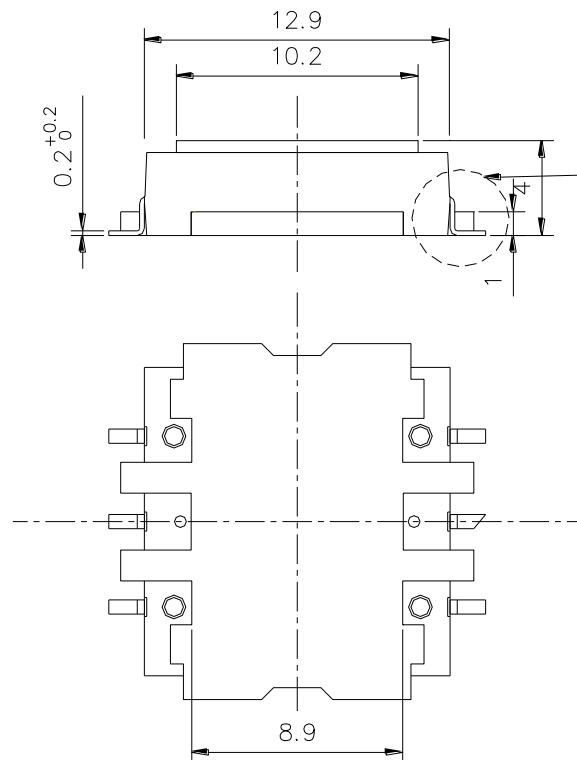
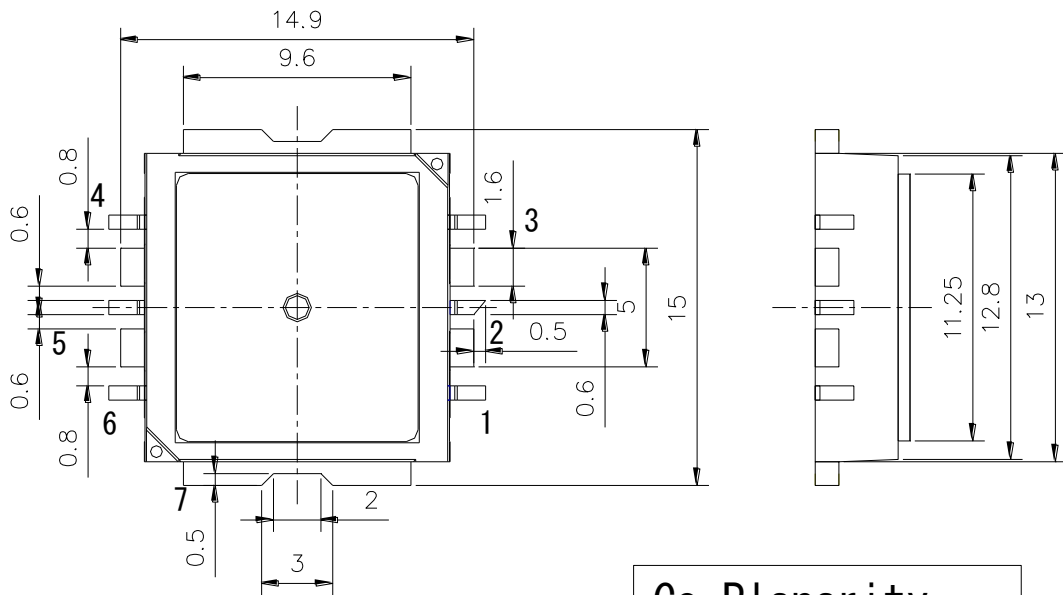

Pin Assignments

1	: NC
2	: Gate
3	: NC
4	: NC
5	: Drain
6	: NC
7	: Source

● PCB Pads and Solder-Resist Pattern

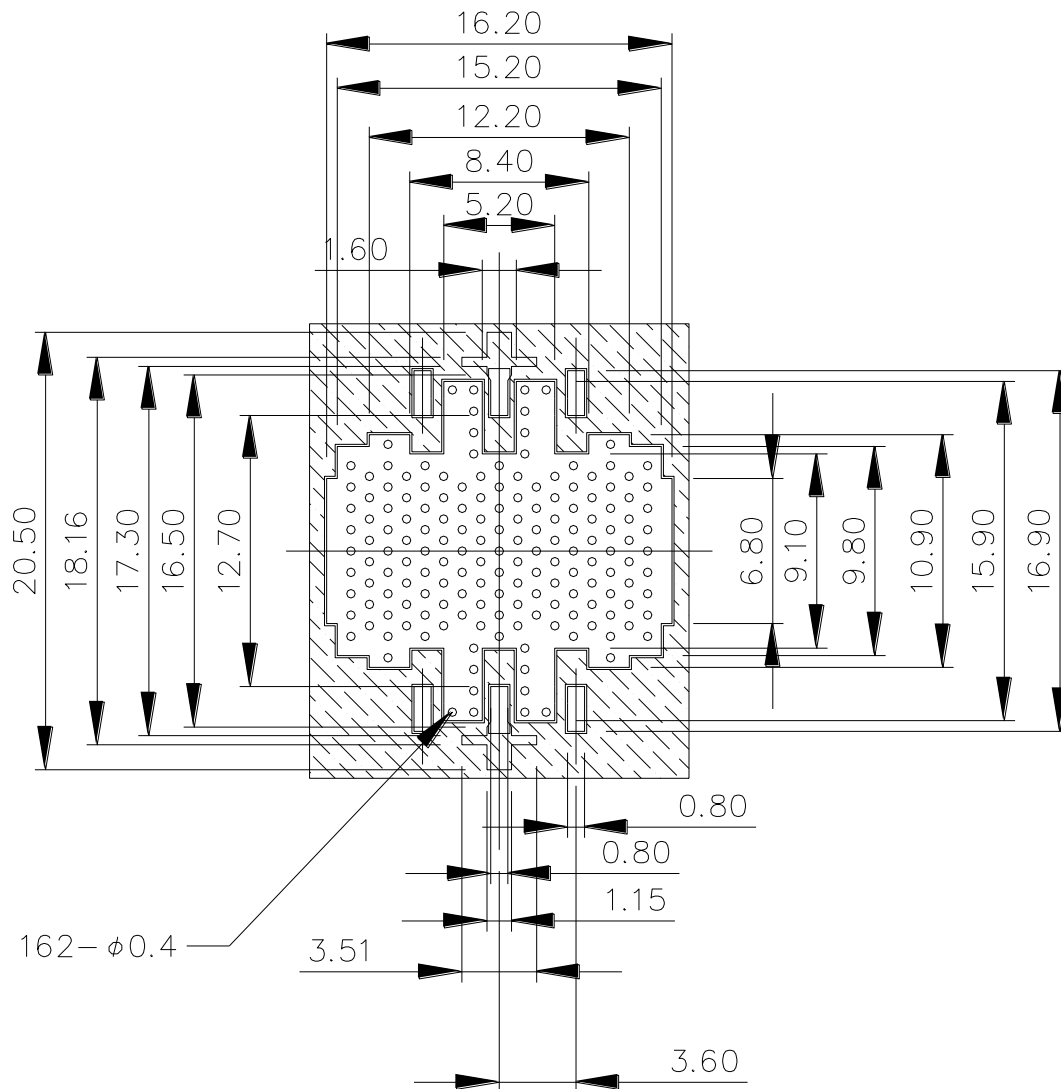

Notes :

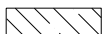
1. Laminate : Rogers Corporation R04003, Thickness $t=0.508\text{mm}$, Cu Foil $18\mu\text{m}$.
Finish to copper foil : Ni $0.1\mu\text{m}$ min. / Au $0.1\mu\text{m}$ (Both side).
2.  : Resist

● Marking and Tape/Reel Configuration

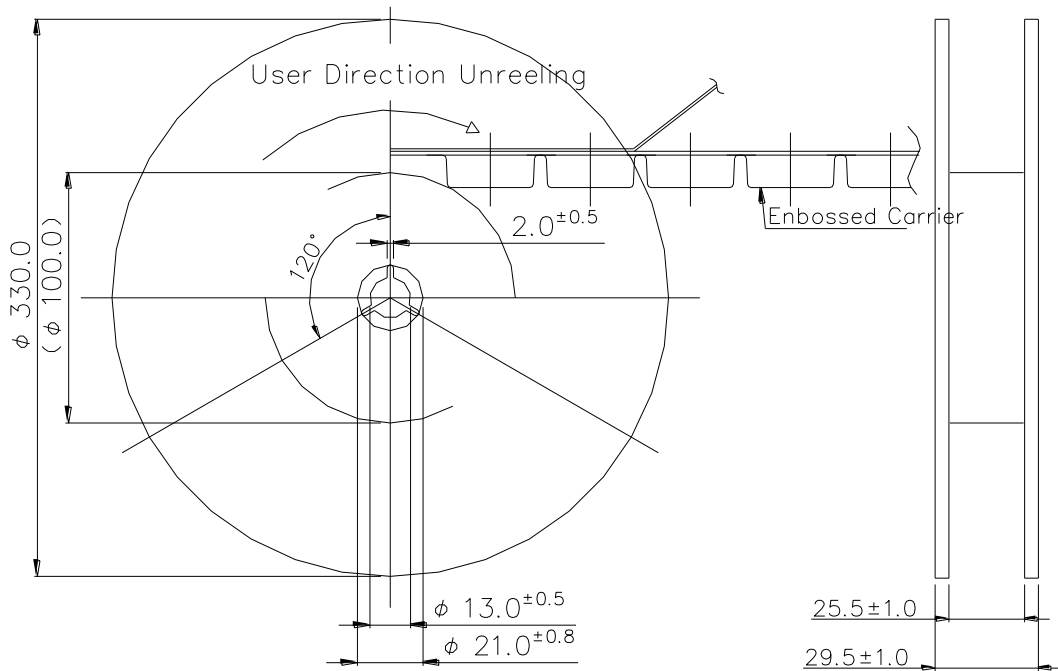
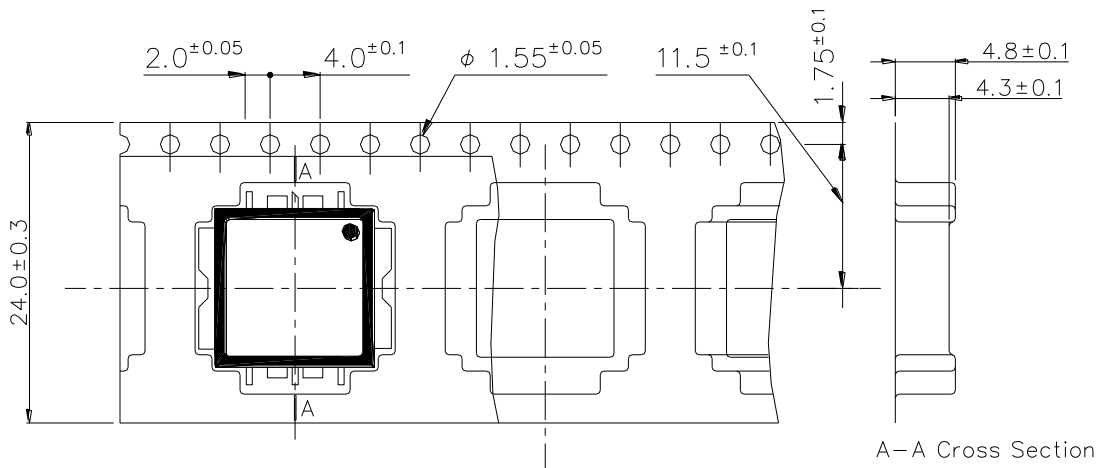

Quantity: 500pcs/tape
Tape Material: Conductive PS

(unit in mm)

● Mounting Instructions for Package for Lead-free solder

Mounting Condition

For soldering, Lead-free solder (Sn-3.0Ag-0.5Cu)*1 or equivalent shall be used.

1. The example solder is a tin-rich alloy with 3.0% silver and 0.5% copper, often called Sn 96 for its approximate Tin content.
2. A rosin type flux with chlorine content of 0.2% or less shall be used. The rosin flux with low halogen content is recommended. When soldering, use the following time/ temperature profile with any of the methods listed for acceptable solder joints.
3. Make sure the devices have been properly prepared with flux prior soldering.

* Reflow soldering method (Infrared reflow / Heat circulation reflow / Hot plate reflow);

Limit solder to 3 reflow cycles because resin is used in the modules manufacturing process.

Excessive reflow will effect the resin resulting in a potential failure or latent defect.

The recommended reflow temperature profile is shown below. The temperature of the reflow profile must be measured at the device lead.

● Reflow temperature profile and condition:

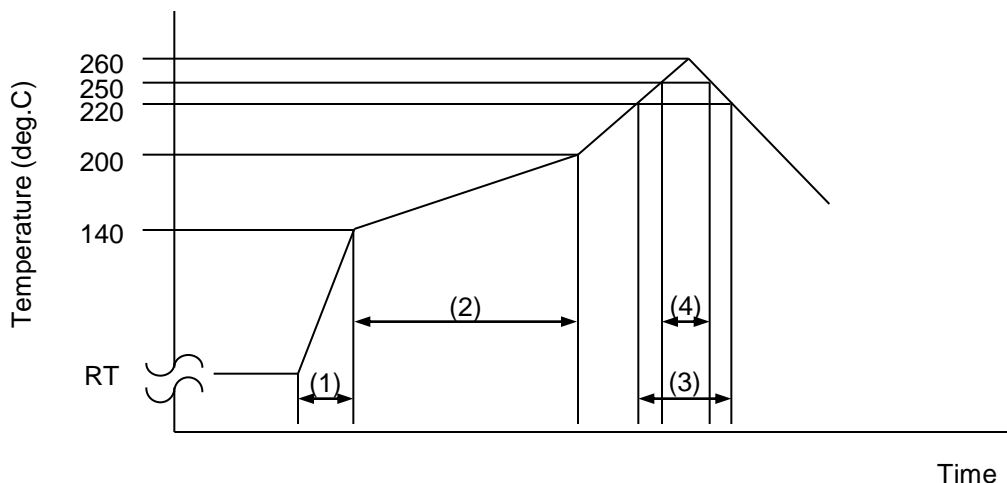

- (1). Temperature rise: 3 deg.C/seconds.
- (2). Preheating: 150 to 200 deg.C, 60 to 180seconds.
- (3). Main heating: 220 deg.C, 60 seconds max.
- (4). Main heating: 260 deg.C max., more than 250 deg.C, 20 to 40 seconds max.

* Measurement point: Device Heat-sink (Source Pin).

1. The above-recommended conditions were confirmed using the manufacturer's equipment and materials. However, when soldering these products, the soldering condition should be verified by customer using their own particular equipment and materials.

● Cleaning

Avoid washing of the device after soldering by reflow method due to the risk of liquid absorption by the resin used in this part.

Humidity Lifetime for ELMxxxx-4PST

The following graph shows the effect of moisture on lifetime (moisture resistance) for the ELMxxxx-4PST. Each graph indicates the MTTF and failure rate prediction (Confidential Level = 90 %) which calculated from the results of highly accelerated temperature and humidity stress test (HAST).

Representative of device type : ELM7179-4PST

Subject of device type : ELMxxxx-4PST

Field environmental conditions for operation

If the **ELMxxxx-4PST** is installed in a non-hermetic environment, please refer to the following recommendations and notes for design with, and assembly and use of our products.

- Note 1. When drain current cuts off, it should be cut off by drain bias, and not cut off by gate bias only. The humidity lifetime becomes shorter in case of the gate-only cut off operation due to electric field strength interacting with humidity.
- Note 2. **ELMxxxx-4PST** should be used under the environment conditions of no dew condensation. These plots do not apply in the case of liquid absorbed into the resin, whether applied to the part in assembly or as condensate in the application.

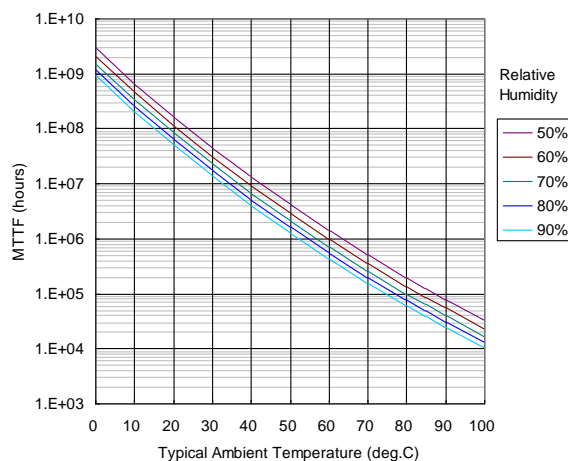
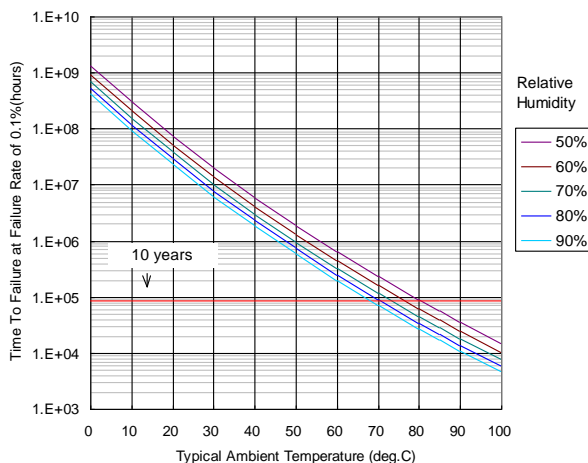

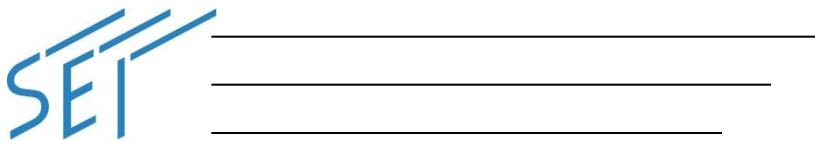

ELM7179-4PS

C-Band Internally Matched FET

For further information please contact:

<http://global-sei.com/Electro-optic/about/office.html>

CAUTION

This product contains **gallium arsenide (GaAs)** which can be hazardous to the human body and the environment. For safety, observe the following procedures:

- Do not put these products into the mouth.
- Do not alter the form of this product into a gas, powder, or liquid through burning, crushing, or chemical processing as these by-products are dangerous to the human body if inhaled, ingested, or swallowed.
- Observe government laws and company regulations when discarding this product. This product must be discarded in accordance with methods specified by applicable hazardous waste procedures.