

300mA High PSRR Low Noise, Adjustable LDO Regulator

General Description

The EM1101 performs ultra low drop voltage, high power supply rejection ratio (PSRR), fast response, low noise linear regulator, and designed to continuously deliver up to 300mA output current. The EM1101 has wide adjustable output voltage range and high feedback voltage accuracy to 1.5%.

No by-pass capacitor is needed for this device and only 1uF ceramic capacitor is required for stability in any loading conditions. It reduces the amount of board space necessary for power applications.

The other features include soft start, current limit protection, Power-On-Reset function, and over temperature protection. The EM1101 is available in SOT-23-5 package.

Ordering Information

Part Number	Package	Remark
EM1101J	SOT-23-5L	

Features

- Ultra Fast Response in Line/Load Transient
- Wide V_{IN} Range from 2.5V to 5.5V
- Adjustable Output Voltage from 0.8V to 4.5V
- Ultra Low Dropout Voltage: 200mV @300mA
- High Power Supply Rejection Ratio
 - 70dB at 1kHz
 - 60dB at 10kHz
- Ultra Low Output Noise Voltage 100uV_(RMS)
- Low Shutdown Current < 1uA
- Only 1uF Ceramic Capacitor required for stability
- Over Temperature Protection
- Current Limit Protection
- RoHS Compliant and 100% Lead (Pb)-Free

Applications



- Cellular Handsets
- Battery-Powered Equipment
- Laptop, Palmtops, Notebook Computers
- Hand-Held Instruments
- PCMCIA Cards
- Portable Information Applications

Pin Configuration

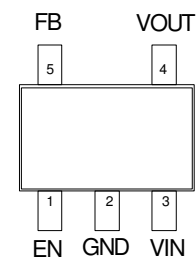

Typical Application Circuit

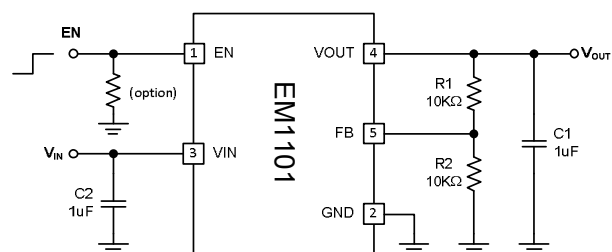

Pin Assignment

Pin Name	Pin No.	Pin Function
EN	1	Chip Enable Input (Active high).
GND	2	Ground.
VIN	3	Input Voltage. This is the source input to the power device that supplies current to the output pin.
VOUT	4	Output Voltage. VOUT is power output pin. An internal pull low resistance exists when the device is disabled. Minimum 1uF low ESR ceramic capacitor is required at this pin for stabilizing VOUT voltage.
FB	5	Feedback Voltage. FB is the non-inverting input to the error amplifier. A resistor divider from the output to GND is used to set the regulation voltage as $V_{OUT} = 0.8 * (1 + R_1/R_2)(V)$. This pin has high impedance and should be kept from noisy source to guarantee stable operation.

Function Block Diagram

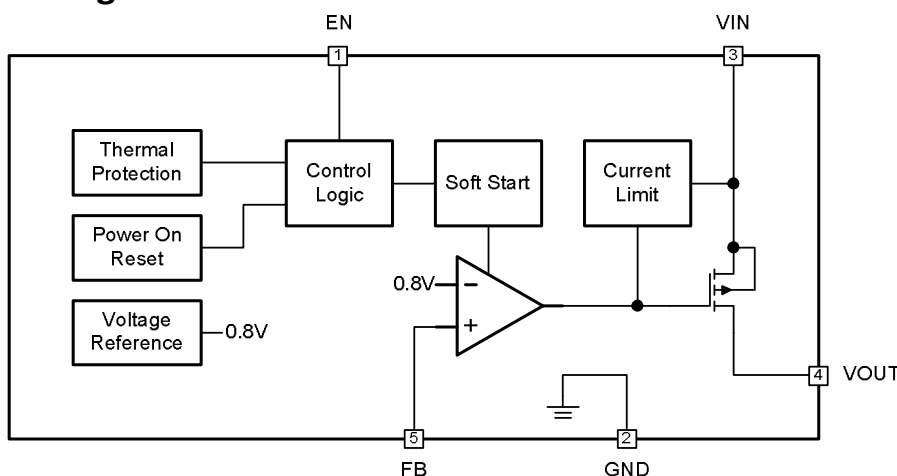

Absolute Maximum Ratings (Note1)

- V_{IN} ----- -0.3V to +6.0V
- Other Pins ----- -0.3V to ($V_{IN}+0.3V$)
- Power Dissipation, $P_D @ T_A = 25^{\circ}C$, SOT23-5 ----- 0.4W
- Package Thermal Resistance, θ_{JA} , SOT23-5 (Note 2) ----- 250°C/W
- Junction Temperature ----- 150°C
- Lead Temperature (Soldering, 10 sec.) ----- 260°C
- Storage Temperature ----- -65°C to 150°C
- ESD susceptibility (Note3)
 - HBM (Human Body Mode) ----- 2KV
 - MM (Machine Mode) ----- 200V

Recommended Operating Conditions (Note4)

- Supply Input Voltage, V_{IN} ----- +2.5V to +5.5V
- Junction Temperature ----- -40°C to 125°C
- Ambient Temperature ----- -40°C to 85°C

Electrical Characteristics
 $V_{IN}=5V$, $T_A=25^{\circ}C$, unless otherwise specified

Parameter	Symbol	Test Conditions	Min	Typ	Max	Units
Supply Input Section						
Power Input Voltage	V_{IN}	$V_{OUT}=V_{REF}$	2.5	-	5.5	V
POR Threshold	V_{PORTH}		-	2.0	2.4	V
POR Hysteresis	V_{PORHYS}		-	0.2	-	V
Quiescent Current	I_Q	$V_{IN}=V_{EN}=5V$, $I_{OUT}=0A$	-	90	130	μA
Shutdown Current	I_{SD}	$V_{IN}=5V, V_{EN}=0V$	-	0.1	1	μA
Output Voltage						
Feedback Voltage	V_{FB}	$V_{IN}=V_{EN}=5V$, $I_{OUT}=1mA$	0.788	0.8	0.812	V
Line Regulation	$V_{OUT(LINE)}$	$2.5V < V_{IN} < 5.0V$, $I_{OUT}=1mA$, $V_{OUT}=V_{REF}$	-	-	0.2	%/V
Load Regulation	$V_{OUT(LOAD)}$	$1mA < I_{OUT} < 300mA$, $V_{IN}=V_{OUT}+0.5V$	-	0.5	1	%/A
Output Voltage Noise		10Hz to 100kHz, $C_{OUT}=1\mu F$	-	100	-	$\mu V_{(RMS)}$
Power Supply Rejection Ratio	PSRR	$I_{OUT}=10mA, 1kHz$	-	70	-	dB
		$I_{OUT}=10mA, 10kHz$	-	60	-	
		$I_{OUT}=10mA, 100kHz$	-	40	-	
Dropout Voltage	V_{DROP}	$I_{OUT}=300mA$, $2.5V < V_{OUT} < 3.3V$	-	200	300	mV
Enable						
Enable High Level	V_{EN}		1.4	-	-	V
Disable Low Level	V_{SD}		-	-	0.38	V
Enable Input Current	I_{EN}	$V_{EN}=5V$ or $0V$	-1	0	1	μA
Output Voltage Ramp Up Time			-	600	-	us
Over Current Protection						
OCP Threshold Level	I_{OCP}	$V_{IN}=V_{EN}=5V$, $V_{OUT}=V_{REF}$	360	600	-	mA
Thermal Protection						
Thermal Shutdown Temperature	T_{SD}	$V_{IN}=V_{EN}=5V$, $I_{OUT}=0A$, $V_{OUT}=V_{REF}$	-	160	-	$^{\circ}C$
Thermal Shutdown Hysteresis	T_{SDHYS}	$V_{IN}=V_{EN}=5V$, $I_{OUT}=0A$, $V_{OUT}=V_{REF}$	-	30	-	$^{\circ}C$

Note 1. Stresses listed as the above "Absolute Maximum Ratings" may cause permanent damage to the device. These are for stress ratings. Functional operation of the device at these or any other conditions beyond those indicated in the operational sections of the specifications is not implied. Exposure to absolute maximum rating conditions for extended periods may remain possibility to affect device reliability.

Note 2. θ_{JA} is measured in the natural convection at $T_A=25^{\circ}C$ on a low effective thermal conductivity test board (Single layout, 1S) of JEDEC 51-3 thermal measurement standard.

Note 3. Devices are ESD sensitive. Handling precaution is recommended.

Note 4. The device is not guaranteed to function outside its operating conditions.

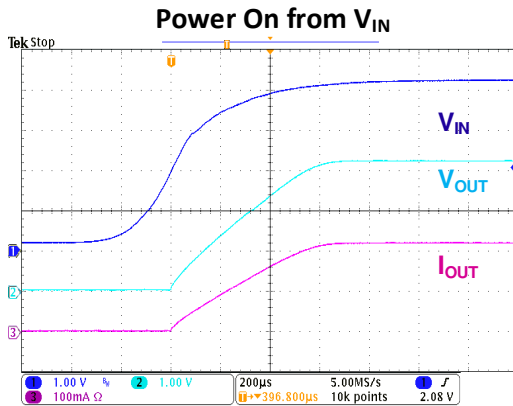

$V_{OUT}=3.3V$, $C_{IN}=C_{OUT}=1\mu F$, $R_{OUT}=15\Omega$

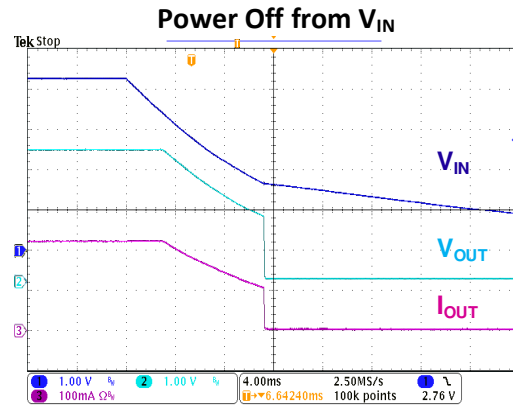

$V_{OUT}=3.3V$, $C_{IN}=C_{OUT}=1\mu F$, $R_{OUT}=15\Omega$

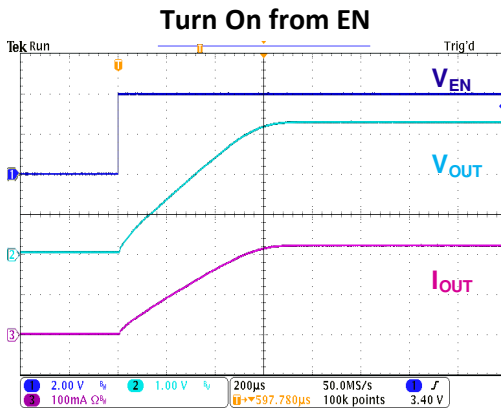

$V_{OUT}=3.3V$, $C_{IN}=C_{OUT}=1\mu F$, $R_{OUT}=15\Omega$

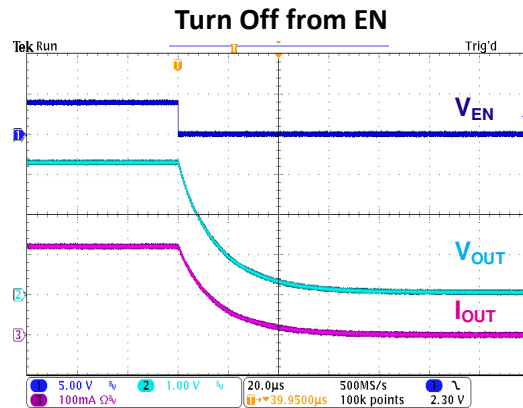

$V_{OUT}=3.3V$, $C_{IN}=C_{OUT}=1\mu F$, $R_{OUT}=15\Omega$

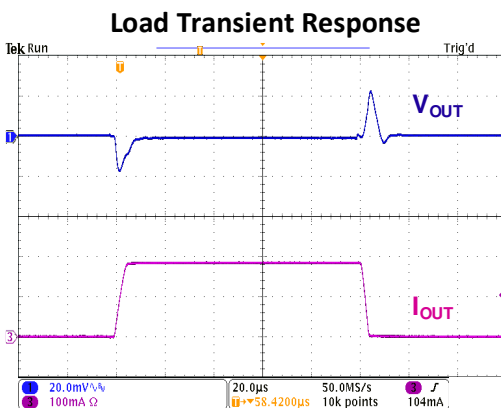

$V_{OUT}=3.3V$, $C_{IN}=C_{OUT}=1\mu F$

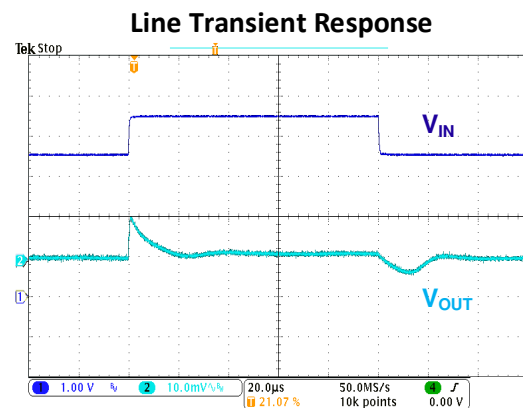

$V_{OUT}=2.5V$, $C_{IN}=C_{OUT}=1\mu F$, $V_{IN}=3.5V$ to $4.5V$.

Dropout Voltage v.s. Output Current

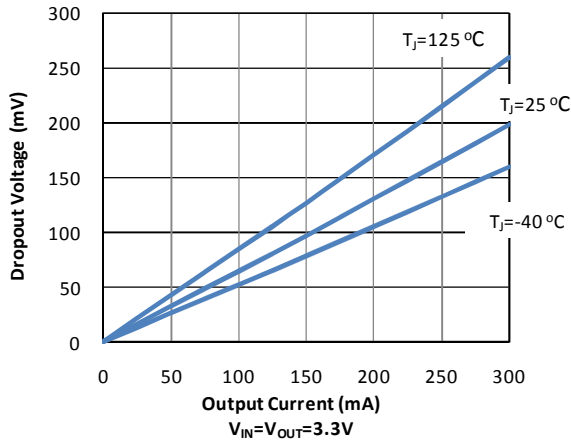

Quiescent Current v.s. Input Voltage

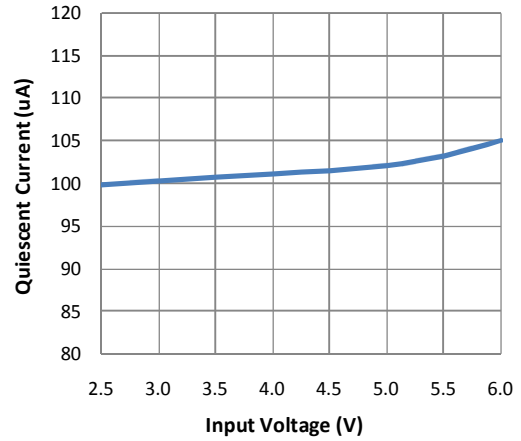

On Resistance v.s. Input Voltage

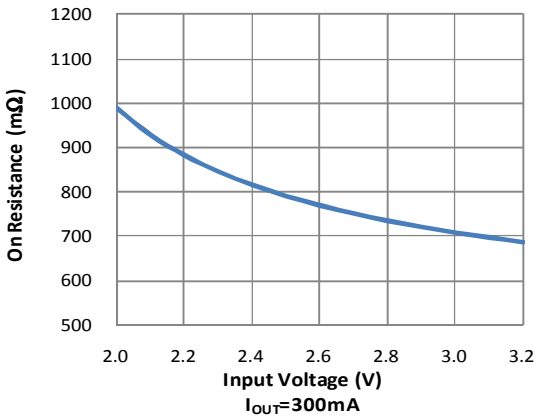

Output Voltage Line Regulation

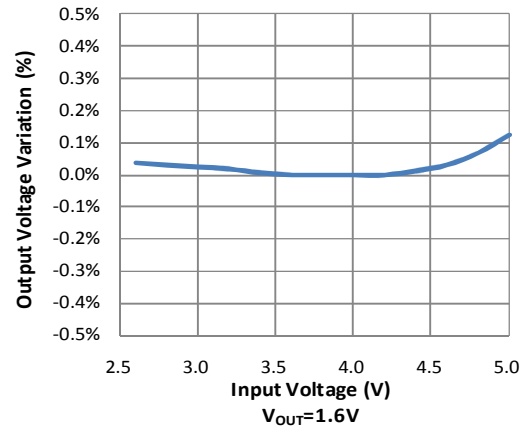

Pull Low Resistance v.s. Input Voltage

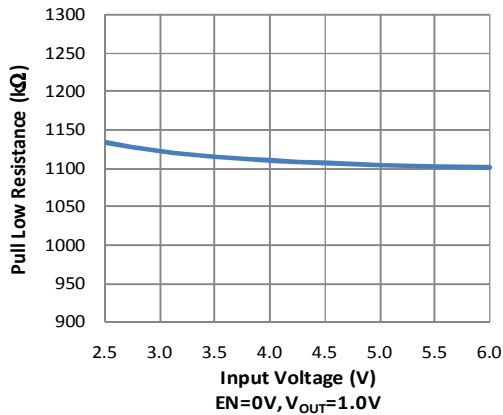

Enable/Disable v.s. Input Voltage

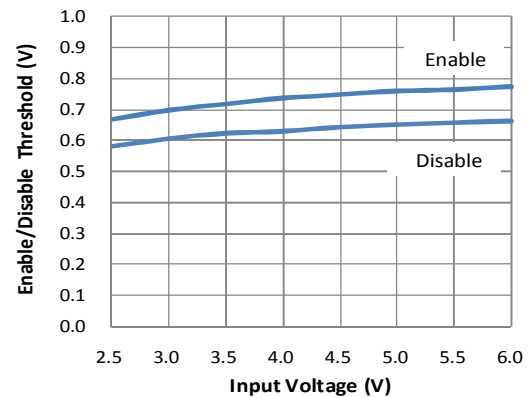

Output Voltage v.s. Temperature

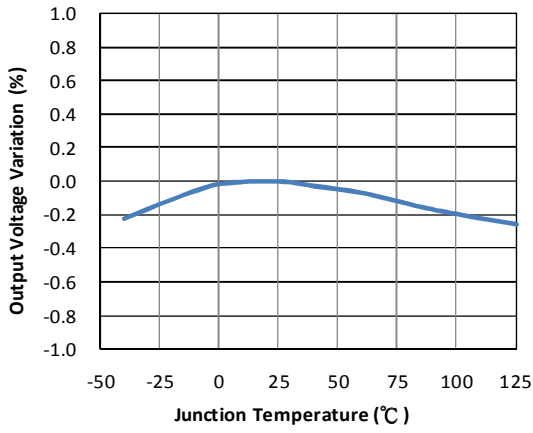

Quiescent Current v.s. Temperature

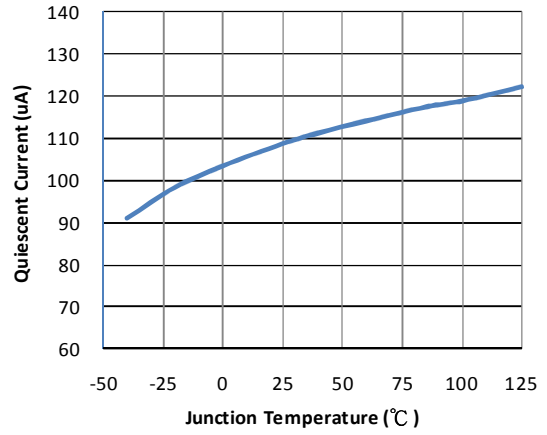

Shutdown Current v.s. Temperature

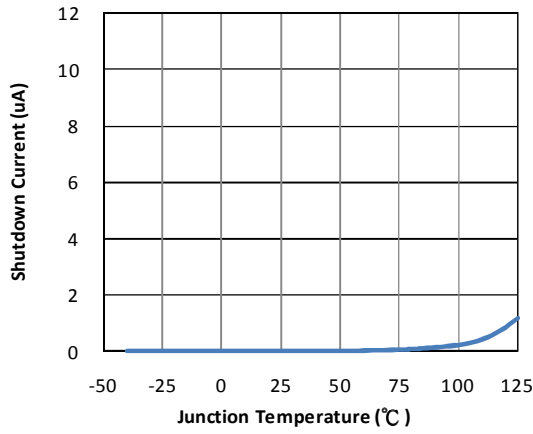

On Resistance v.s. Temperature

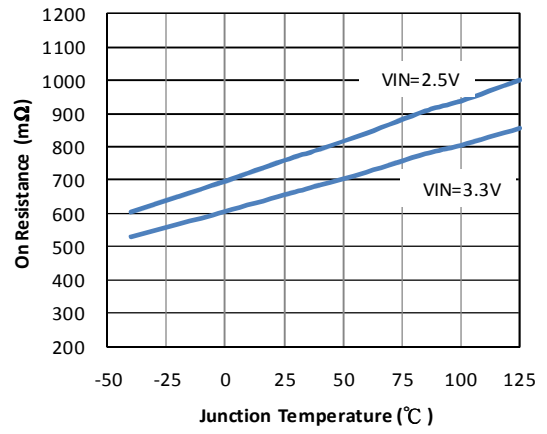

Enable/Disable v.s. Temperature

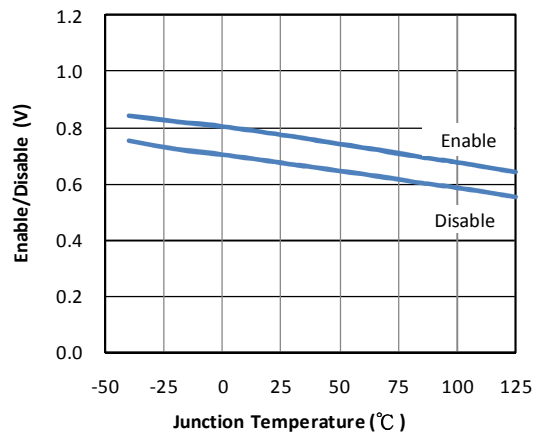

PSRR

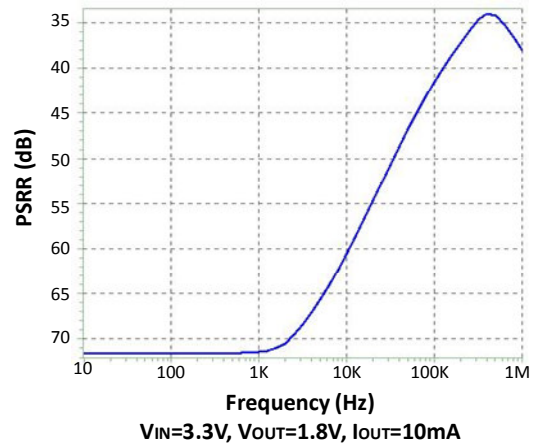

Functional Description

Enable Function

EM1101 is enabled if the voltage of the EN pin is greater than 1.4V. If the voltage of the EN pin is less than 0.38V, the IC will be disabled.

POR – Power ON Reset

To let EM1101 start to operation, input voltage must be higher than its POR voltage even when EN voltage is pulled higher than enable high voltage. Typical POR voltage is 2.0V.

VOUT Voltage Adjustment

The VOUT voltage of EM1101 can be adjusted by external voltage divider. Refer to typical application circuit, VOUT voltage is calculated by the following equation,

$$V_{OUT} = \left(1 + \frac{R_1}{R_2}\right) \times 0.8V$$

Over Current Limit Function

EM1101 features over current limiting function which can limit its output current to 600mA.

Input and Output Capacitor Selection

For VIN pin, 1uF or larger ceramic capacitor is required to provide bypass path in transient current demand. VOUT pin is also recommended to have 1uF or larger ceramic capacitor to be stable and reduce the VOUT voltage dip when fast loading transient is happened.

Power Dissipation

The max power depends on some conditions, including of thermal impedance, PCB layout, airflow, and so on. The max power dissipation can be calculated by the formula as below

$$P_{D(max)} = (T_{J(max)} - T_A) / \theta_{JA}$$

$T_{J(max)}$ is the max junction temperature; θ_{JA} is the thermal impedance from junction to ambient. The thermal impedance θ_{JA} of SOT23-5 is package design and PCB design dependent.

For recommended specification of EM1101, the

max junction temperature is 125 degree C. The θ_{JA} of SOT23-5 is 250°C/W on the standard JEDEC 51-3 thermal test board. The max power dissipation (at 25°C ambient) can be calculated as below:

$$P_{D(max \text{ at } 25^\circ C)} = (125^\circ C - 25^\circ C) / (250^\circ C/W) = 0.4W$$

Ordering & Marking Information

Device Name: EM1101J for SOT-23-5

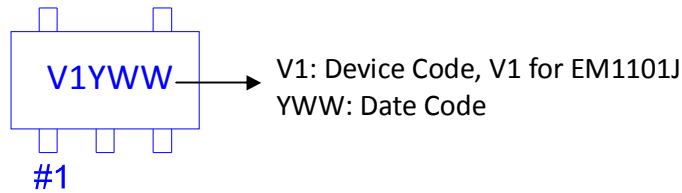

Outline Drawing

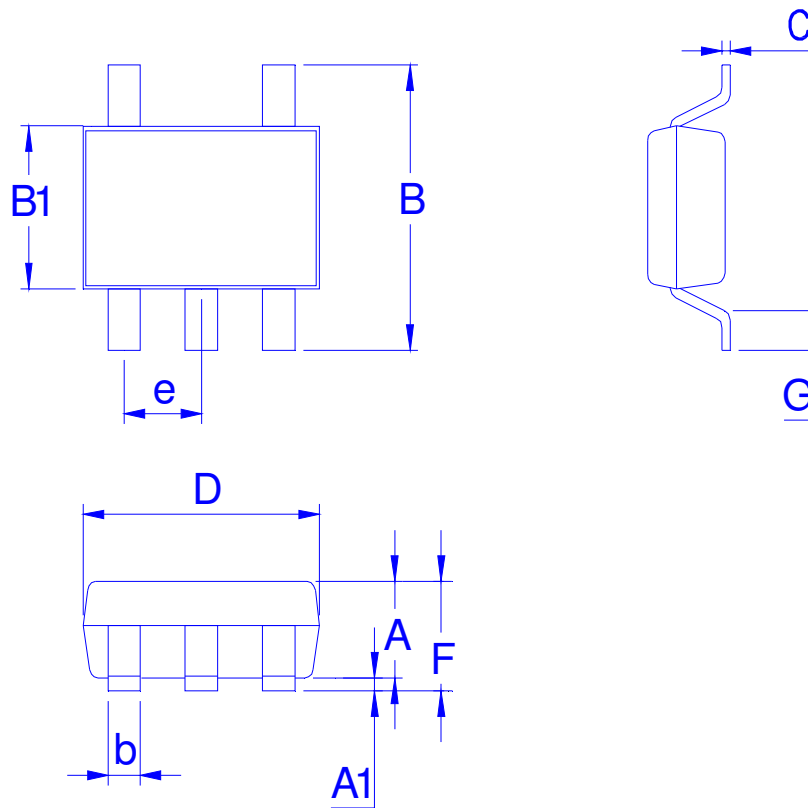

Dimension in mm

Dimension	A	A1	B	B1	b	C	D	e	F	G
Min.	0.90	0.00			0.30	0.08				0.30
Typ.	1.15		2.80	1.60			2.90	0.95		0.45
Max.	1.30	0.15			0.50	0.22			1.45	0.60