

## ***EM2860***

### ***USB Video Capture Device***

EM2860 Supports Video Decoder, Audio Decoder, and VBI

SUPREME

### ***Hardware Specification***

---

## **DISCLAIMER**

EMPIA Technology reserves the right to make changes in the device data identified in this publication without further notice. EMPIA Technology advises its customers to obtain the latest version of all device data to verify that any information being relied upon by the customer is current and accurate.

EMPIA Technology does not assume any liability arising out of or associated with the application or use of any product or integrated circuit or component described herein. EMPIA Technology does not convey any license under its patent rights or the patent rights of others described herein. In the absence of a written or prior stated agreement to the contrary, the terms and conditions stated on the back of the EMPIA Technology order acknowledgment obtain.

EMPIA Technology makes no warranty of any kind with regard to this material, including, but not limited to the implied warranties of merchantability and fitness for a particular purpose.

EMPIA Technology products are not designed, intended, or authorized for use as components in systems intended for surgical implant into the body, or other applications intended to support or sustain life, or for any nuclear facility application, or for any other application in which the failure of the EMPIA Technology product(s) could create a situation where personal injury or death may occur. EMPIA Technology will not knowingly sell its products for use in such applications, and the buyer shall indemnify and hold harm-less EMPIA Technology and its officers, employees, subsidiaries, affiliates, representatives, and distributors against all claims, costs, damages, expenses, tort, and attorney fees arising out of directly or indirectly, any claim of personal injury or death associated with such unintended or unauthorized use, even if such claim alleges that EMPIA Technology was negligent regarding the design or manufacture of the part.

## **Features**

### **No external memory required**

### **Flexible Video Input Port**

- 8-bit video input port
- Support up to 1.3 M pixel CMOS sensor in Bayer RGB format
- Interlace and non-interlace video
- CCIR-601 4:2:2 YUV with external sync and field ID
- CCIR-656 YUV with embedded sync and field ID

### **Programmable Video Timing Generator**

- Generate clock, H-sync and V-sync for CMOS sensor

### **Bayer RGB Color Processor**

- Black clamping
- Gamma correction
- Bayer pattern filtering
- Gain and offset adjustment in RGB space
- 9-window image statistics collection for auto exposure and auto white balance
- Defect pixel compensation

### **YUV Color Processor**

- Gain and offset adjustment in YUV space
- Sharpness enhancement

### **Video Scaler**

- Random-ratio down scaling in X and Y directions
- High fidelity color reproduction by the scaler

### **VBI Capture**

- Raw VBI capture
- Sliced VBI capture

### **Audio Interface**

- Support AC97 CODEC
- Support I<sup>2</sup>S device
- Software direct access to AC97 CODEC registers
- Support audio sample rates of 48K, 44.1K, 32K, 16K, and 8K.
- Support USB Audio Class control and streaming

### **Remote Controller Infrared Sensor Interface**

- Support NEC and RC5 remote control protocols

### **USB Port**

- Integrated USB 2.0 PHY with High-Speed and Full-Speed Transceivers
- Second generation USB 2.0 PHY with reduced power
- USB 2.0 and 1.1 compliant

Support Iso-chronous audio pipe up to 0.2 MB/sec  
Support Iso-chronous video pipe up to 30 MB/sec  
Support Iso-chronous transport stream pipe up to 3 MB/sec

### **EEPROM Interface**

Support 256, 512, 1024 or 2048-byte 2-wire serial EEPROM  
Use EEPROM to store chip configurations and USB descriptors  
Customized Vendor ID and Product ID  
Customized Vendor String, Product String, and Serial Number String  
Software may use EEPROM to store board configurations  
Software may use EEPROM to store defect pixel coordinates

### **Miscellaneous**

2-wire serial bus to program front-end video/audio devices  
Power-down control to front-end video/audio devices  
8 general-purposed I/O ports  
Snap shot button input  
LED control output  
0.22 micron, 2.5V Core, 3.3V I/O CMOS process  
64-pin LQFP package

SUPREME

## Functional Block Diagram

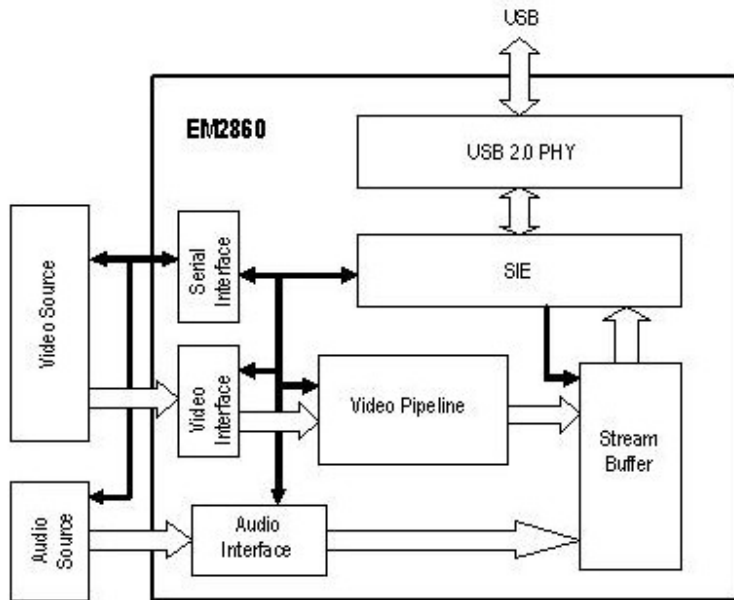

## Pin Assignments

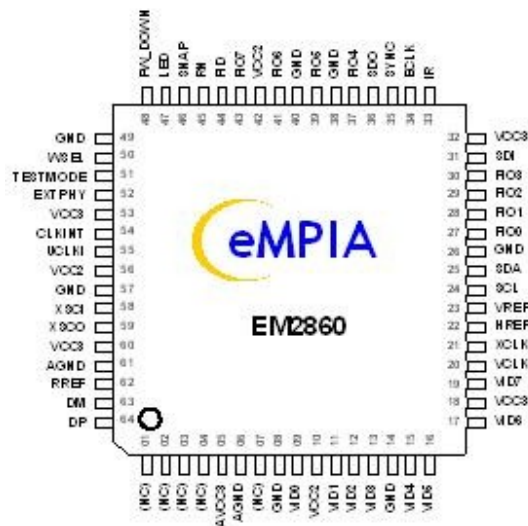

## **General Description**

EM2860 USB Video Capture Device (UVCD) is a highly integrated VLSI that provides a cost-effective solution for video capture applications on USB 2.0. Typical applications of this device are:

- *CMOS PC-Camera*
- *NTSC/PAL Video Capture*

As illustrated in the functional block diagram, an USB video subsystem consists of the UVCD, a video source, and optionally an audio source. The video source can be a CMOS sensor or an NTSC/PAL video decoder. The audio source can be an AC97 codec or an I<sup>2</sup>S stereo decoder. The USB host configures (programs) the video/audio source via the 2-wire serial bus or the AC97-link. Source video stream is transferred to the UVCD via the 8-bit video bus. Source audio stream is transferred to the UVCD via the AC97-link or the I<sup>2</sup>S bus.

As shown in the functional block diagram, the UVCD consists of 7 main blocks.

- *Video Interface*
- *Video Pipeline*
- *Audio Interface*
- *Stream Buffer*
- *Serial Interface Engine*
- *USB 2.0 PHY*
- *2-Wire Serial Interface*

### **Video Interface**

The Video Interface Block receives video data from external video source. Video clock (VCLK) and reference signals (VREF, HREF) from the video source are used to strobe incoming video data. CCIR-656 with embedded FID, VREF and HREF is also supported.

From the incoming video, a rectangular video sub-block is selected for feeding the next block, Video Pipeline.

The Video Interface Block also includes a video timing generator that generates HREF and VREF for slave-mode CMOS sensor.

### **Video Pipeline**

The Video Pipeline Block performs the following operations.

- *Black Clamping*
- *Gamma Correction*
- *RGB Gain and Offset*
- *Defect Pixel Compensation*
- *Up-Sampling 8-bit Bayer to 24-bit RGB,*
- *Color Space Conversion to YUV,*
- *Pixel Accumulation for AE and AWB*
- *Down Scaling*
- *Sharpness Enhancement*
- *Contrast, Brightness, and Saturation Adjustments*
- *UV Offset Adjustments*
- *Output Formatting*

- *Image Compression*

After the above operations, the compressed video is stored into the Stream Buffer.

## Audio Interface

The Audio Interface Block contains an AC97 controller and an I<sup>2</sup>S slave. Only one is enabled by configuration settings in EEPROM.

The AC97 controller interfaces with an external AC97 codec via 4-wire AC97-link. Supported audio sample rates are 48K, 44.1K, 32K, 16K, and 8K.

The I<sup>2</sup>S slave interfaces with an external I<sup>2</sup>S master via 3-wire I<sup>2</sup>S bus. The master is typically a stereo decoder. Supported audio sample rates are 48K, 44.1K, and 32K.

The Audio Interface Block converts the serial audio input to PCM16 format and stores into the Stream Buffer.

## Stream Buffer

The Stream Buffer stores the final audio and video data and delivers the data to the SIE upon request. The Stream Buffer is designed to sustain 24 MB/sec iso-chronous video transfer and 0.2 MB/sec iso-chronous audio transfer.

## Serial Interface Engine

The Serial Interface Engine can be divided into 2 sub-blocks: the SIE Controller on the front end and the Endpoint Logic on the back end. The SIE Controller manages USB packets and transactions. The Endpoint Logic implements endpoint specific logic required for video capture application. The SIE communicates with the USB 2.0 PHY via UTMI bus.

The UVCD complies with USB power management standard. When the USB bus stays idle for 3 mini seconds, the chip enters suspend mode and shuts down all internal clocks. The chip also sends out a power-down signal to external devices.

## USB 2.0 PHY

The USB 2.0 PHY includes 12-MHz Full-Speed transceivers, 480-MHz High-Speed transceivers, a PLL, and an UTMI controller. The transceivers are compliant to the USB 2.0 electrical specification. The PLL supplies clocks to the entire chip. The UTMI controller communicates with the SIE. The PHY has been optimized for low power. Furthermore, the PHY can be suspended by the SIE to conserve power.

## Serial Port and General I/O Port

The UVCD uses a two-wire serial bus to communicate with CMOS sensor or NTSC decoder. The serial port consists of SCL (clock) and SDA (data). Both are open-collector bi-directional ports. External pull-up resistors are required on both lines.

There are 8 general I/O ports. All general I/O ports are open-collector bi-directional pins. If a port is intended for output, it must be tied to external pull-up resistors.

## Pin Descriptions

### Video Interface

Symbol	Pin No.	Type	Description
XCLK	21	O	Video synchronous clock output
VCLK	20	I	Video reference clock from video source
VREF	23	B	Vertical reference (sync) signal from video source in input mode. Video timing generator vertical reference output in output mode.
HREF	22	B	Horizontal reference (sync) signal from video source in input mode. Video timing generator horizontal reference output in output mode.
FID	44	I	Field ID from video source
VID7	19	I	Video input data, bit 7
VID6	17	I	Video input data, bit 6
VID5	16	I	Video input data, bit 5
VID4	15	I	Video input data, bit 4
VID3	13	I	Video input data, bit 3
VID2	12	I	Video input data, bit 2
VID1	11	I	Video input data, bit 1
VID0	9	I	Video input data, bit 0

### Audio Interface

Symbol	Pin No.	Type	Description
BCLK	34	I	AC97/I <sup>2</sup> S bit clock
SDI	31	I	AC97/I <sup>2</sup> S serial data input
SYNC	35	O	AC97 48 KHz fixed rate sample sync
SDO	36	O	AC97 serial data output
WSEL	50	I	I <sup>2</sup> S word select at audio sample rate

### USB Interface

Symbol	Pin No.	Type	Description
DP	64	B	USB differential data positive
DM	63	B	USB differential data negative
RREF	62	Analo	Connect reference resistor (12.1 KOhm, 0.1%) to Analog Ground
XSCI	58	Analo	Crystal oscillator input 12 MHz
XSCO	59	Analo	Crystal oscillator output 12 MHz



**Serial Bus and Programmable I/O**

Symbol	Pin No.	Type	Description
SCL	24	B	Serial bus clock, require external pull-up resistor.
SDA	25	B	Serial data, require external pull-up resistor.
PIO7	43	B	General I/O port 7, require external pull-up resistor in output mode.
PIO6	41	B	General I/O port 6, require external pull-up resistor in output mode.
PIO5	39	B	General I/O port 5, require external pull-up resistor in output mode.
PIO4	37	B	General I/O port 4, require external pull-up resistor in output mode.
PIO3	30	B	General I/O port 3, require external pull-up resistor in output mode.
PIO2	29	B	General I/O port 2, require external pull-up resistor in output mode.
PIO1	28	B	General I/O port 1, require external pull-up resistor in output mode.
PIO0	27	B	General I/O port 0, require external pull-up resistor in output mode.

**Remote Control Infrared Sensor Interface**

Symbol	Pin No.	Type	Description
IR	33	I	Infrared sensor signal

## Miscellaneous

Symbol	Pin No.	Type	Description
RN	45	I	Chip reset input. Active low. Connect to power-up RC circuit.
SNAP	46	I	Connect to snapshot button
LED	47	O	Connect to LED
PW_DOW	48	O	Power down external devices.
TESTMO	51	I	Put the chip in test mode. Normally tie to GND
EXTPHY	52	I	Select and use external PHY. Normally tie to GND
CLKINT	54	I	Select and use internal PLL. Normally tie to 3.3V VCC
UCLKI	55	I	Chip clock input when CLKINT=0. Normally tie to GND

## Power and Ground

Symbol	Pin No.	Type	Description
AVCC3	5, 60	Power	3.3V Analog Power
AGND	6, 61	Ground	Analog Ground
VCC3	18, 32, 53	Power	3.3V Digital Power
VCC2	10, 42, 56	Power	2.5V Digital Power
GND	8, 14, 26, 38, 40, 49, 57	Ground	Digital Ground
(NC)	1, 2, 3, 4, 7		No connect to internal die

## EEPROM Data Structure

EEPROM contains hardware configuration information. After reset by RN, the UVCD reads the EEPROM and uses the information to configure the chip. The first four bytes of the EEPROM are Key to the EEPROM. If the EEPROM is absent or the Key is invalid, the UVCD is configured with a set of default values.

Addr.	Data Definition	Default
00H	Key Byte 0 = 1AH	-
01H	Key Byte 1 = EBH	-
02H	Key Byte 2 = 67H	-
03H	Key Byte 3 = 95H	-
04H	USB Vendor ID Low Byte	1AH
05H	USB Vendor ID High Byte	EBH
06H	USB Product ID Low Byte	*
07H	USB Product ID High Byte	*
08H	Chip Configuration Low Byte D[7] Class audio or vendor audio 0 – Inform the host that the chip is USB audio class device 1 – Inform the host that the chip is vendor specific audio device D[6] USB audio class volume control capability when audio source is I <sup>2</sup> S device. When audio source is AC97, the chip is always capable of volume control regardless of the state of this bit. 0 – Inform the host that the chip is not capable of volume control. 1 – Inform the host that the chip is capable of volume control. D[5:4] Audio Configuration 00 – No audio on board. 01 – AC97 audio on board with 5 sample rates: 48K, 44.1K, 32K, 16K, and 8K. 10 – I <sup>2</sup> S audio on board with 3 sample rate: 32K, 16K, and 8K. 11 – I <sup>2</sup> S audio on board with 5 sample rates: 48K, 44.1K, and 32K, 16K, and 8K. D[3] USB Remote Wakeup Capable when set to 1 D[2] USB Self Power Capable when set to 1. If the chip is configured to be Self Power Capable, PIO7 becomes self power status input. D[1:0] USB Max Power Select 00 – USB Max Power 500 mA 01 – USB Max Power 400 mA 10 – USB Max Power 300 mA 11 – USB Max Power 200 mA	**
09H	Chip Configuration High Byte D[7:5] Reserved. Set to 0. D[4] Transport stream on board 0 – Inform the host that the chip supports transport stream. 1 – Inform the host that the chip does not support transport stream. D[3:2] Transport stream iso-chronous request interval 00 – Inform the host that request interval is 0 (one request every micro-frame) 01 – Inform the host that request interval is 1 (one request every 2 micro-frames) 10 – Inform the host that request interval is 2 (one request every 4 micro-frames) 11 – Inform the host that request interval is 3 (one request every 8 micro-frames) D[1:0] Transport stream MaxPacketSize select 00 – Inform the host that MaxPacketSize is 188*1 bytes 01 – Inform the host that MaxPacketSize is 188*2 bytes 10 – Inform the host that MaxPacketSize is 188*3 bytes 11 – Inform the host that MaxPacketSize is 188*4 bytes	00H

0AH	Board Configuration Low Byte To be defined by Software Architect	00H
0BH	Board Configuration High Byte To be defined by Software Architect	00H
0CH	String 1 Descriptor Pointer Starting address of String 1 Descriptor in the EEPROM	00H
0DH	String 1 Descriptor Length Number of bytes of String 1 Descriptor in the EEPROM	00H
0EH	String 2 Descriptor Pointer Starting address of String 2 Descriptor in the EEPROM	00H
0FH	String 2 Descriptor Length Number of bytes of String 2 Descriptor in the EEPROM	00H
10H	String 3 Descriptor Pointer Starting address of String 3 Descriptor in the EEPROM	00H
11H	String 3 Descriptor Length Number of bytes of String 3 Descriptor in the EEPROM	00H
12H	String Index Table D[7:6] Reserved. Set to 0. D[5:4] Serial Number String Descriptor Index D[3:2] Product String Descriptor Index D[1:0] Vendor String Descriptor Index	00H
24H	Minimum Audio Volume (2's complement number) This is audio class minimum audio volume to report to the host so that the host will not set any volume smaller than this.	F0H
25H	Maximum Audio Volume (2's complement number) This is audio class maximum audio volume to report to the host so that the host will not set any volume bigger than this.	10H

**Note:**

- \* Default Product ID is listed below:

Chip Type	Product ID (w.o. audio)	Product ID (w. audio)
EM2860	2860H	2861H

- \*\* Default Chip Configuration Low Byte = 00H if PIO7 is pulled down with a resistor.  
Default Chip Configuration Low Byte = 10H if PIO7 is pulled up with a resistor.

## Electrical Specifications

### Absolute Maximum Ratings

Parameter	Min	Max	Unit
Power Supply Voltage	-0.3	$V_{CC}+0.3$	V
Voltage on any input	-0.3	5.5	V
Operating Temperature (Ambient)	0	70	°C
Storage Temperature	-40	150	°C

Note:

1. Stress beyond those listed may cause permanent damage to the device.
2. Input pins are 5V tolerant.

### DC Characteristics

Symbol	Parameter	Conditions	Min	Typ	Max	Unit
$V_{CC2}$	Core Supply Voltage		2.25	2.5	2.75	V
$V_{CC3}$	I/O Supply Voltage		3.0	3.3	3.6	V
$V_{CCA}$	Analog Supply Voltage		3.0	3.3	3.6	V
$V_{IH}$	Input High Voltage	$V_{CC3} = 3.3V$	2.0			V
$V_{IL}$	Input Low Voltage	$V_{CC3} = 3.3V$			0.8	V
$V_{OH}$	Output High Voltage		2.4			V
$V_{OL}$	Output Low Voltage				0.4	V
$I_{CC}$	Operating Supply Current				120	mA
$I_{CCS}$	Suspend Supply Current				250	μA
$C_{IN}$	Input Capacitance			3.5		pF
$C_{OUT}$	Output Capacitance			3.5		pF

### AC Characteristics

Symbol	Parameter	Min	Typ	Max	Unit
$f_{XTAL}$	Crystal Frequency at XSCI, XSCO		12		MHz

## Serial Bus Timing

Conditions: 100 KHz SCL; 4.7 KOhm pull up; 100 pF load;

Symbol	Parameter	Min	Typ	Max	Unit
$f_{SCL}$	SCL Frequency		100		KHz
$t_{SCL\_LOW}$	SCL Low Pulse Width	4.7			$\mu$ s
$t_{SCL\_HIGH}$	SCL High Pulse Width	4.0			$\mu$ s
$t_{OSC}$	SDA to SCL Output Delay at START and STOP	4.0		7.0	$\mu$ s
$t_{OSD}$	SCL to SDA Output Delay at START and STOP	4.0		7.0	$\mu$ s
$t_{SDA\_OD}$	SDA Output Delay	4.0		7.0	$\mu$ s
$t_{SDA\_SU}$	SDA Input Setup Time	0			ns
$t_{SDA\_HD}$	SDA Input Hold Time	100			ns

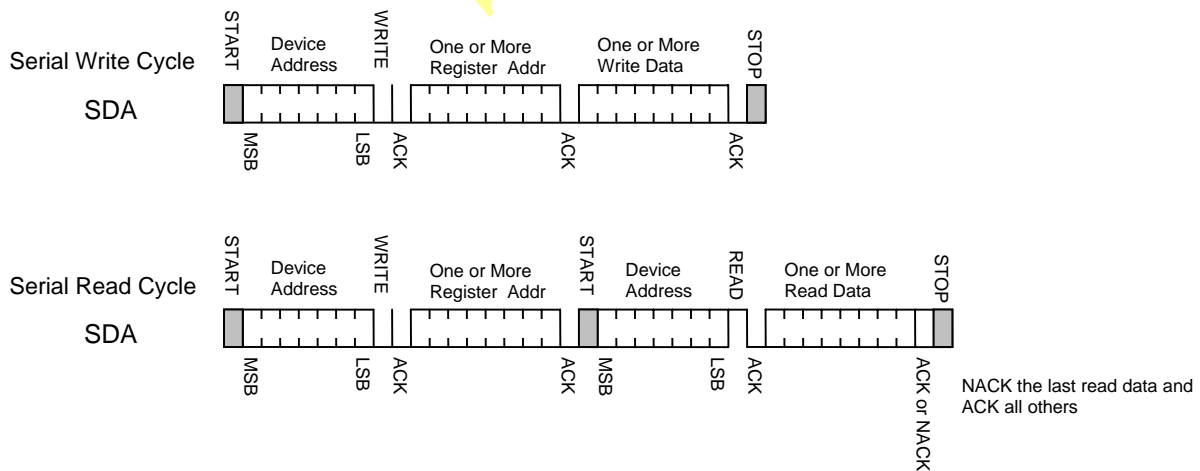
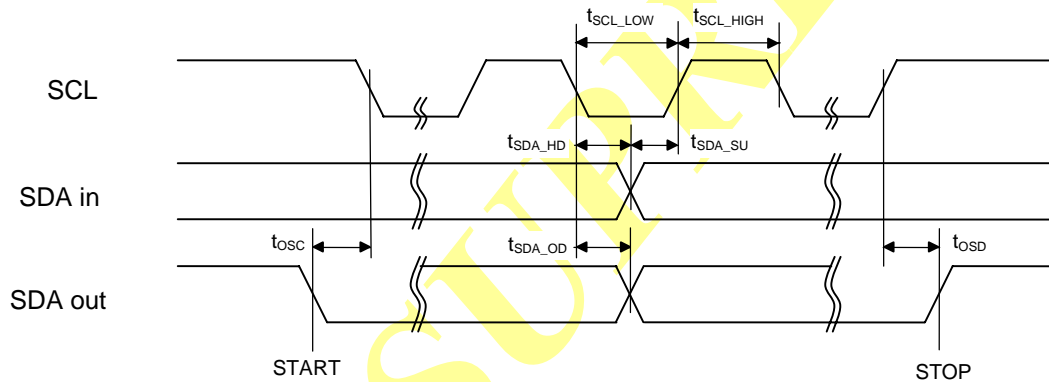

## Video Interface Timing

Conditions: 50 pF load

Symbol	Parameter	Min	Typ	Max	Unit
$f_{VCLK}$	VCLK Frequency			29	MHz
$t_{VC\_LOW}$	VCLK Low Pulse Width	15			ns
$t_{VC\_HIGH}$	VCLK High Pulse Width	15			ns
$t_{V\_OD}$	Video Output Delay	0		10	ns
$t_{V\_SU}$	Video Input Setup Time	10			ns
$t_{V\_HD}$	Video Input Hold Time	10			ns

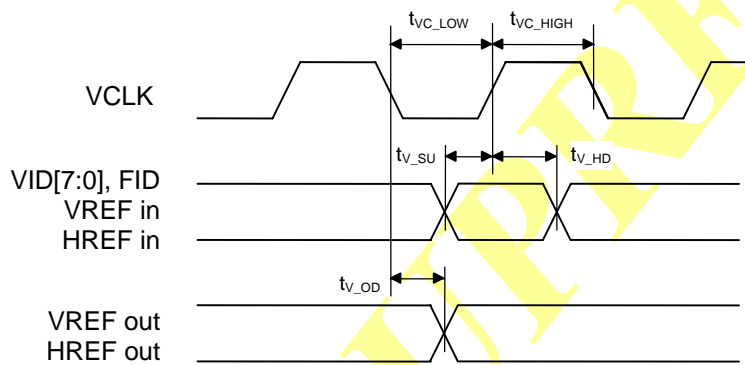

## AC97-Link Timing

Conditions: 50 pF load

Symbol	Parameter	Min	Typ	Max	Unit
$f_{\text{BCLK}}$	BCLK Frequency		12.288		MHz
$f_{\text{SYNC}}$	SYNC Frequency		48		KHz
$t_{\text{BC\_LOW}}$	BCLK Low Pulse Width	36		45	ns
$t_{\text{BC\_HIGH}}$	BCLK High Pulse Width	36		45	ns
$t_{\text{A\_OD}}$	AC97 Data Output Delay	0		15	ns
$t_{\text{A\_SU}}$	AC97 Data Input Setup Time	10			ns
$t_{\text{A\_HD}}$	AC97 Data Input Hold Time	10			ns

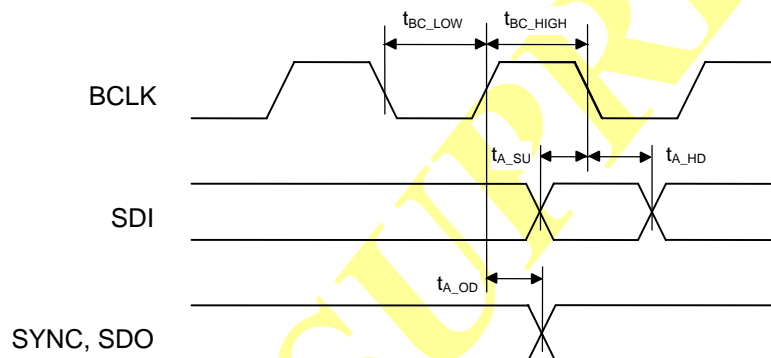



## I<sup>2</sup>S Timing

Conditions: 50 pF load

Symbol	Parameter	Min	Typ	Max	Unit
$f_{BCLK}$	BCLK Frequency			3072	KHz
$f_{WSEL}$	WSEL Frequency			48	KHz
	BCLK Duty Cycle		50		%
$t_{I\_SU}$	I <sup>2</sup> S Data Input Setup Time	10			ns
$t_{I\_HD}$	I <sup>2</sup> S Data Input Hold Time	10			ns

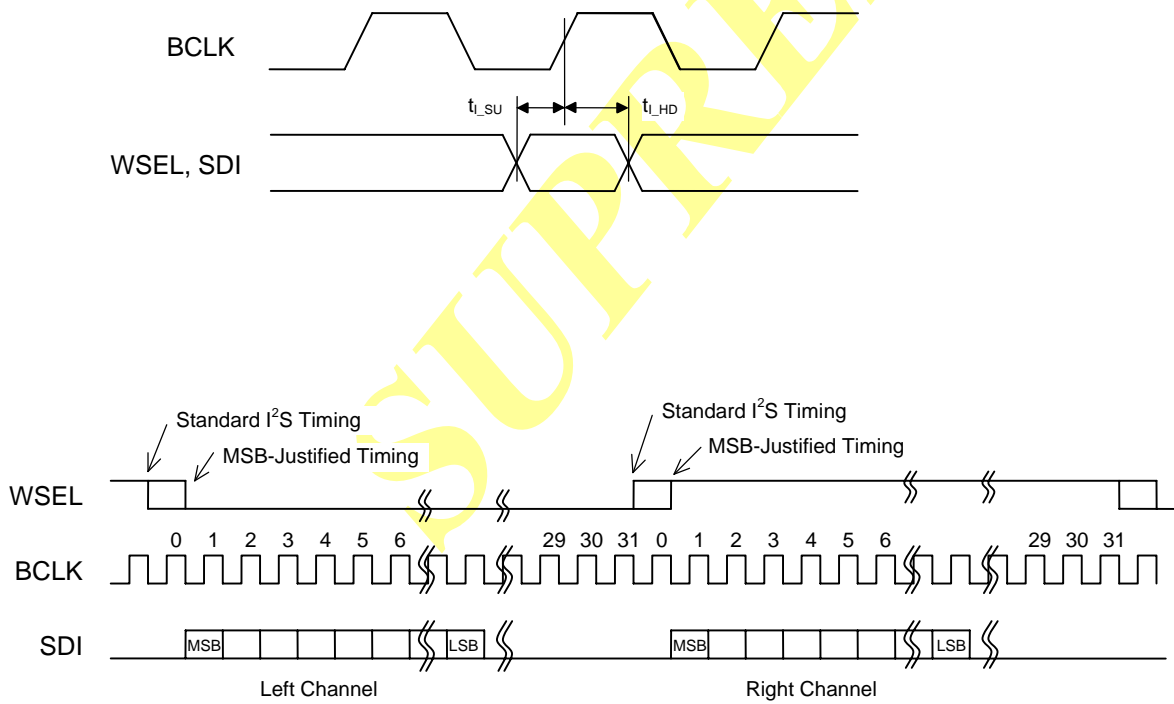

## Packaging Information

### 64-pin (10x10) QFP Mechanical Drawing

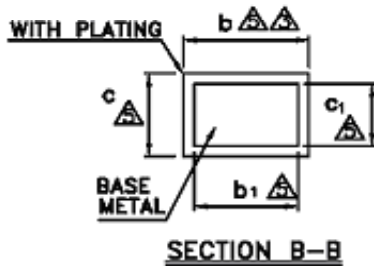
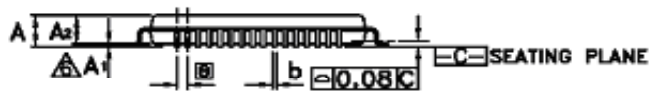
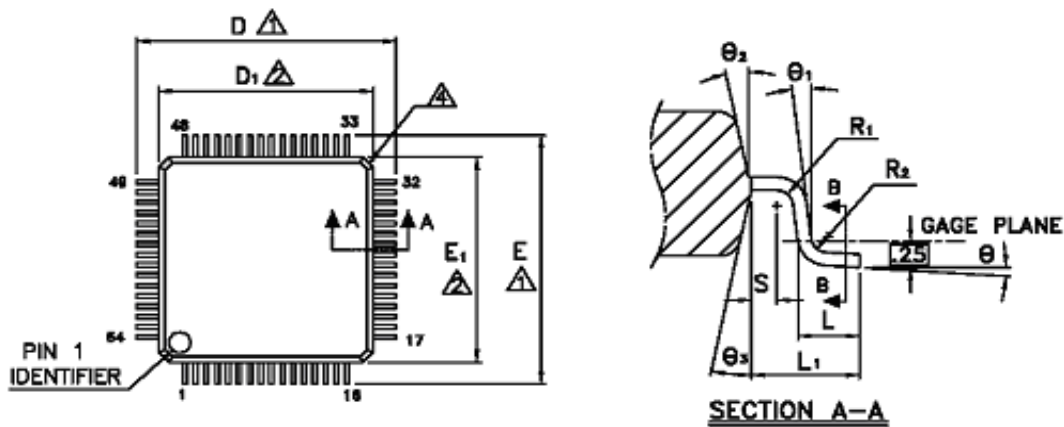

Symbol	Dimension in mm			Dimension in inch		
	Min	Nom	Max	Min	Nom	Max
A	—	—	1.60	—	—	0.063
A <sub>1</sub>	0.05	—	0.15	0.002	—	0.006
A <sub>2</sub>	1.35	1.40	1.45	0.053	0.055	0.057
b	0.17	0.22	0.27	0.012	0.015	0.018
b <sub>1</sub>	0.17	0.20	0.23	0.012	0.014	0.016
c	0.09	—	0.20	0.004	—	0.008
c <sub>1</sub>	0.09	—	0.16	0.004	—	0.006
D	12.00	BSC	—	0.472	BSC	—
D <sub>1</sub>	10.00	BSC	—	0.394	BSC	—
E	12.00	BSC	—	0.472	BSC	—
E <sub>1</sub>	10.00	BSC	—	0.394	BSC	—
⊠	0.50	BSC	—	0.020	BSC	—
L	0.45	0.60	0.75	0.018	0.024	0.030
L <sub>1</sub>	1.00	REF	—	0.039	REF	—
R <sub>1</sub>	0.08	—	—	0.003	—	—
R <sub>2</sub>	0.08	—	0.20	0.003	—	0.008
S	0.20	—	—	0.008	—	—
θ	0°	3.5°	7°	0°	3.5°	7°
θ <sub>1</sub>	0°	—	—	0°	—	—
θ <sub>2</sub>	12°	TYP	—	12°	TYP	—
θ <sub>3</sub>	12°	TYP	—	12°	TYP	—

### 64-pin LQFP (7X7) Mechanical Drawing

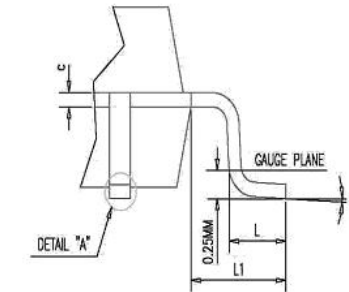
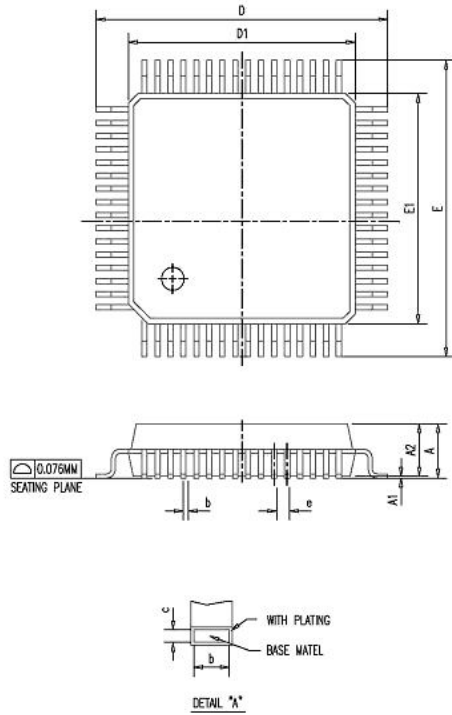

SYMBOL	DIMENSION IN MM			DIMENSION IN INCH		
	MIN.	NOM.	MAX.	MIN.	NOM.	MAX.
A			1.60			0.063
A1	0.05		0.15	0.002		0.006
A2	1.35	1.40	1.45	0.053	0.055	0.057
D	8.90	9.00	9.10	0.350	0.354	0.358
D1	6.90	7.00	7.10	0.272	0.276	0.280
E	8.90	9.00	9.10	0.350	0.354	0.358
E1	6.90	7.00	7.10	0.272	0.276	0.280
e	0.40 BSC.			0.016 BSC.		
b	0.16 BSC.			0.006 BSC.		
c	0.127 TYP.			0.005 TYP.		
L	0.50	0.60	0.70	0.020	0.024	0.028
L1	1.00 REF.			0.039 REF.		
theta	0	3.5	7	0	3.5	7
JEDEC						

SUN