



3A Current-Limited Power Distribution Switches

General Description

The EM5203N is an N-channel MOSFET high-side power switch without parasitic body diode between drain and source. The EM5203N provides very low on-resistance as 58mΩ and continuously delivers up to 3A output current. The fault flag output function indicates fault conditions to the local USB controller. The other features include soft start, current limit protection, Power-On-Reset function, and over temperature protection. The EM5203N is available in MSOP-8 package.

Ordering Information

Part Number	Package	Remark
EM5203AN-20	MSOP-8	3A/Active High
EM5203N-20	MSOP-8	3A/Active Low

Features

- Wide Input Range 2.5V to 5.5V
- Low MOSFET On Resistance (58mΩ)
- Low Quiescent (65uA) & Shutdown Current
- Deglitched Open-Drain Fault Flag Output
- Reverse Current Flow blocking
- Power On Reset Function
- Current Limit Protection
- Reverse Voltage Protection
- Over Temperature Protection
- Soft Start and Fast turn off
- Enable Active High or Active Low
- UL Recognized, File No.E468218-A1-CB1

Applications

- USB
- Notebook & Netbook & MB

Pin Configuration

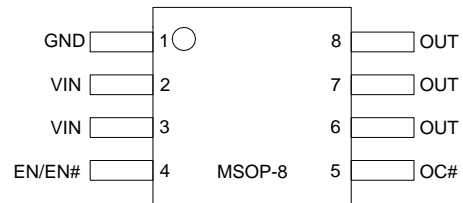

Typical Application Circuit

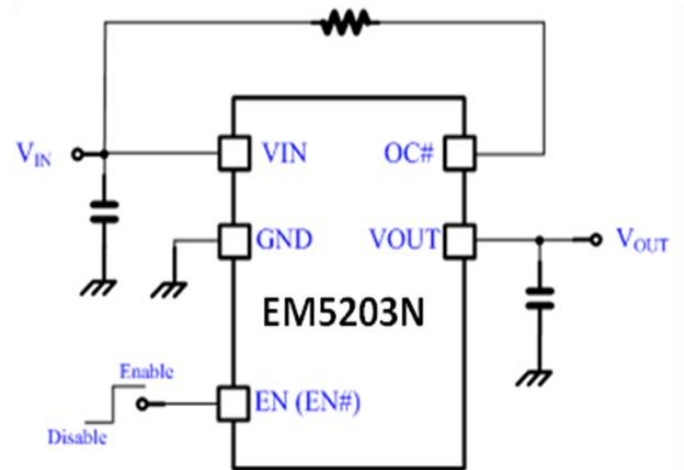

Note: A low ESR 150uF capacitor between VOUT & GND is recommended.

Pin Assignment

Pin Name	Pin No.	Pin Function
GND	1	Ground.
VIN	2,3	Input Voltage. This is the drain input to the power device that supplies current to the output pin. Minimum 1uF low ESR ceramic capacitor is recommended at this pin.
EN / EN#	4	Chip Enable Input (Active high for EN, Active low for EN#)
OC#	5	Fault Flag Output. This is an open-drain output and is set low impedance once current limit or over temperature protection enabled.
VOUT	6,7,8	Output Voltage. VOUT is power output pin.

Function Block Diagram

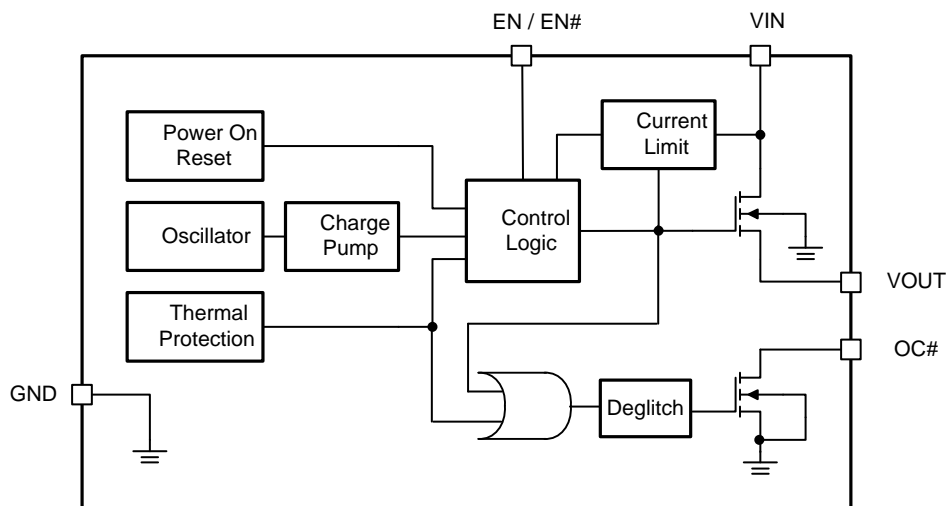

Absolute Maximum Ratings (Note1)

- V_{IN} ----- -0.3V to +6.0V
- Other Pins----- -0.3V to ($V_{IN}+0.3V$)
- Power Dissipation, P_D @ $T_A = 25^\circ C$, MSOP-8 -----0.66W
- Package Thermal Resistance, θ_{JA} , MSOP-8 (Note 2)----- 150°C/W
- Junction Temperature----- 150°C
- Lead Temperature (Soldering, 10 sec.)----- 260°C
- Storage Temperature ----- -65°C to 150°C
- ESD susceptibility (Note3)
 - HBM (Human Body Mode)----- 2KV
 - MM (Machine Mode)----- 200V

Recommended Operating Conditions (Note4)

- Supply Input Voltage, V_{IN} ----- +2.5V to +5.5V
- Junction Temperature ----- -40°C to 125°C
- Ambient Temperature ----- -40°C to 85°C

Electrical Characteristics
 $V_{IN}=5V, T_A=25^{\circ}C$, unless otherwise specified

Parameter	Symbol	Test Conditions	Min	Typ	Max	Units
Supply Input Section						
POR Threshold	V_{PORTH}		-	2.2	2.5	V
Quiescent Current	I_Q	$I_{OUT}=0A$	-	65	95	μA
Shutdown Current	I_{SD}	$EN\#=5V$	-	0.1	1	μA
Output Voltage						
On Resistance	R_{ON}	$I_{OUT}=0.5A$	-	58	65	$m\Omega$
Reverse Leakage Current	I_{REV}	$V_{OUT}=5V, V_{IN}=0V$	-	0.1	2	μA
Soft-Start Time		Rising from 10% to 90%	-	1.5	2	ms
Enable						
Enable High Level	V_{EN}		1.2	-	-	V
Disable Low Level	V_{SD}		-	-	0.5	V
EN Input Current	I_{EN}		-	0.1	1	μA
OC# Flag Output						
OC# Output Resistance	R_{FLGB}	$I_{SINK}=1mA$	-	20	80	Ω
OC# Off Current	I_{FLGB_OFF}	$V_{FLGB}=5V$	-	0.1	1	μA
OC# Delay Time	T_D		8	15	22	ms
OUT Shutdown Discharge Resistance	R_{DIS}			100		Ω
Protection						
OCP Threshold Level	I_{OCP}		3.3	-	4.3	A
Output Short Circuit Current	I_{SC}		1.7		3	A
Thermal Shutdown Temperature	T_{SD}		-	160	-	$^{\circ}C$
Thermal Shutdown Hysteresis	T_{SDHYS}		-	30	-	$^{\circ}C$

Note 1. Stresses listed as the above "Absolute Maximum Ratings" may cause permanent damage to the device. These are for stress ratings. Functional operation of the device at these or any other conditions beyond those indicated in the operational sections of the specifications is not implied. Exposure to absolute maximum rating conditions for extended periods may remain possibility to affect device reliability.

Note 2. θ_{JA} is measured in the natural convection at $T_A=25^{\circ}C$ on a low effective thermal conductivity test board (Single layout, 1S) of JEDEC 51-3 thermal measurement standard.

Note 3. Devices are ESD sensitive. Handling precaution is recommended.

Note 4. The device is not guaranteed to function outside its operating conditions.

Typical Operating Characteristics

Turn on from VIN#

CH1: VIN, CH2:Vo, CH3:OC#

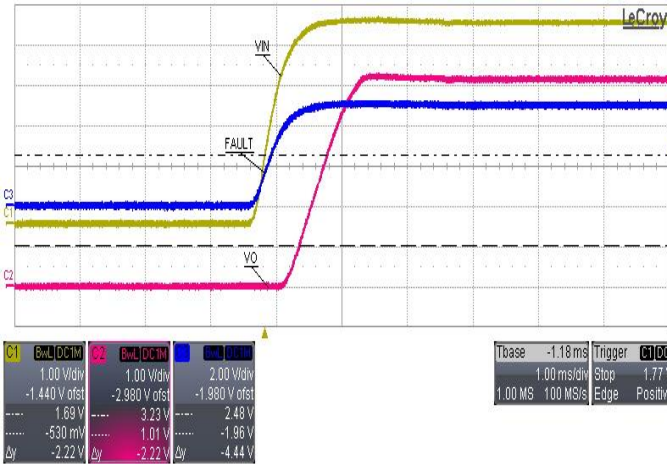

Turn off from VIN#

CH1: VIN, CH2:Vo, CH3:OC#



Reverse Voltage Protection

CH1:VIN, CH2:Vo, CH3: OC#, CH4:IREV

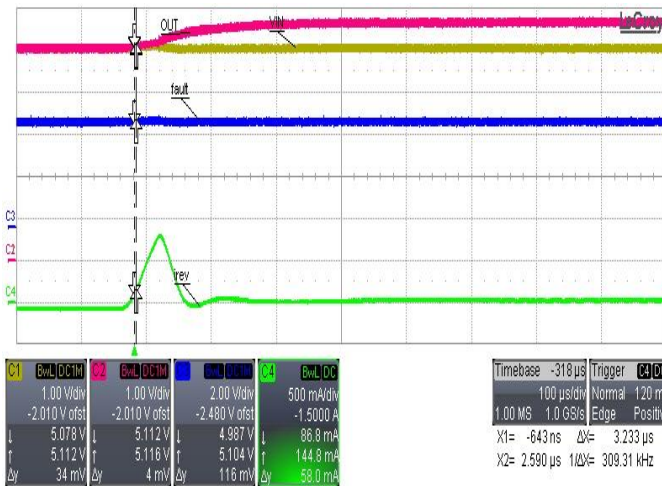

Short then power on into OT cycle

CH1:VIN, CH2:Vo, CH3:OC#



Fault Signal delay time

CH1:VIN, CH2:Vo, CH3:OC#,CH4:I_o



Fault Signal during OTP occurs

CH1:Vo, CH2:OC#, CH4:I_o

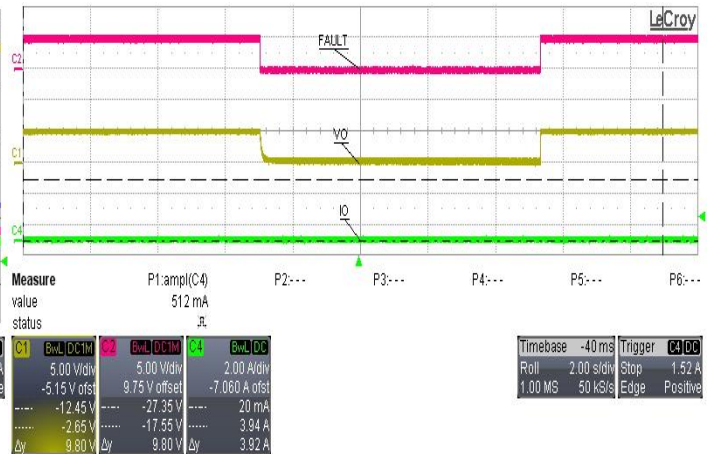

2uS Response for Output short Protection
CH1:VIN, CH2:Vo, CH3:OC#, CH4: IO

Normal operating 2A output current
CH1:Vo, CH2:Fault, CH4:Io

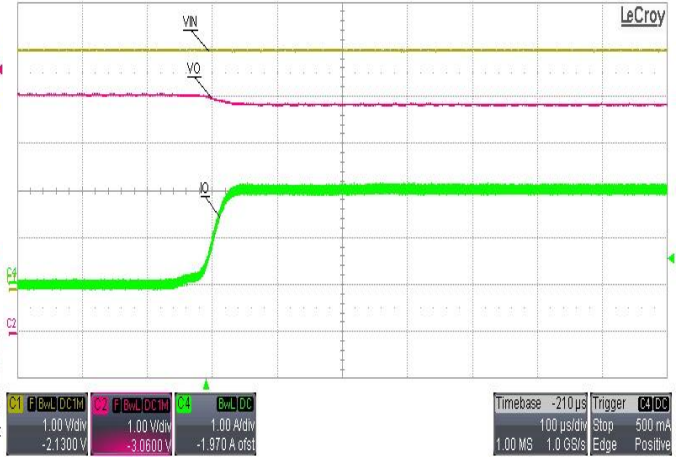
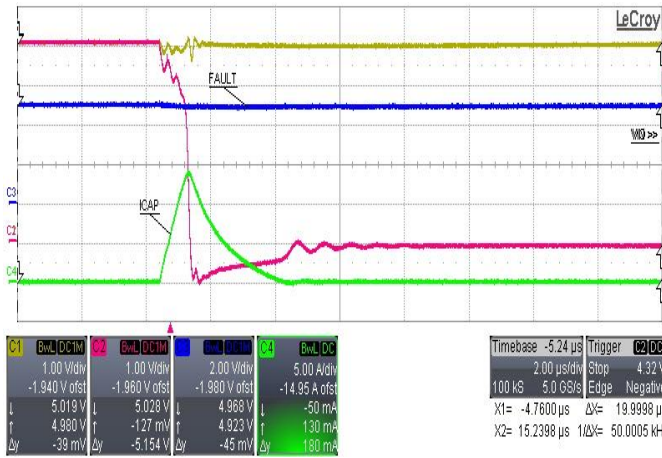

RON Performance VS Temperature

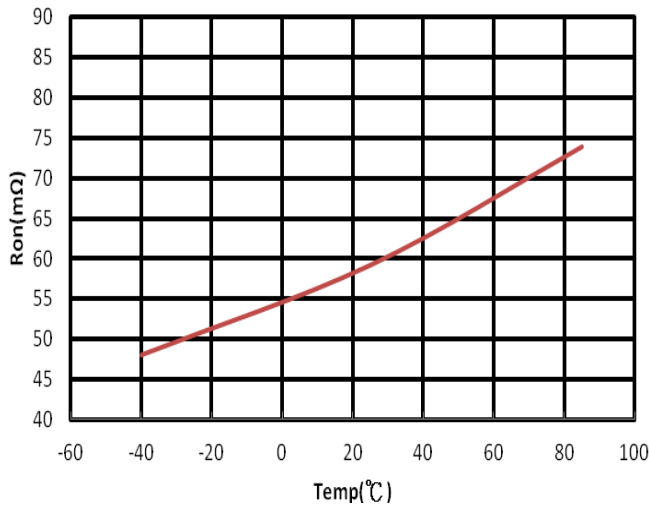

Supply current VS Input Voltage

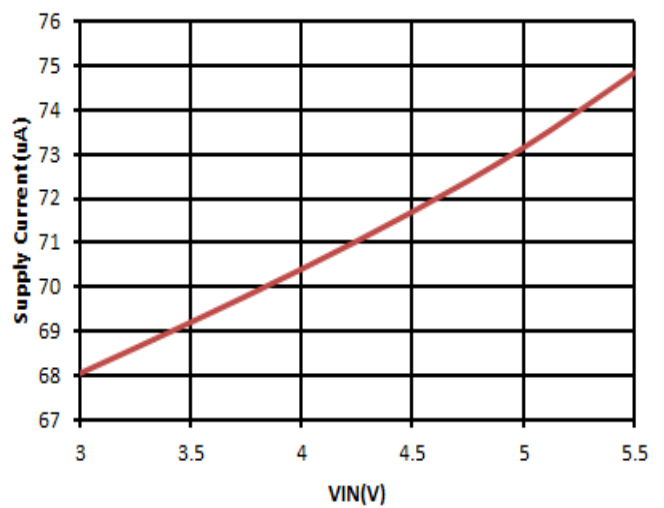

Shut down current VS Input Voltage

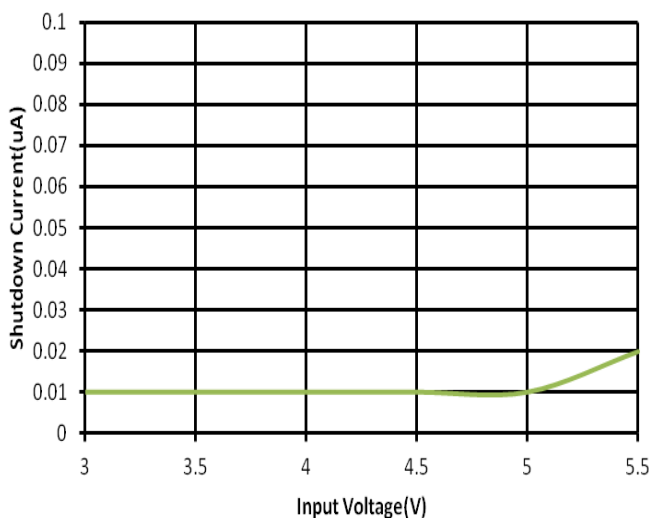

UVLO ON/OFF Voltage VS Temperature

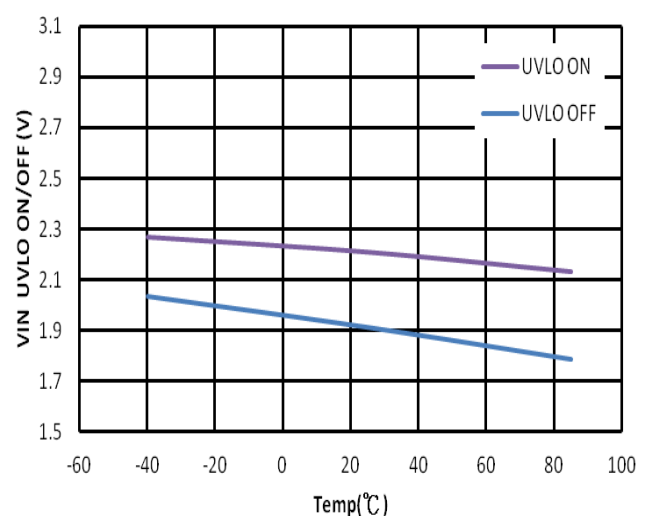



Enable Voltage VS Input Voltage

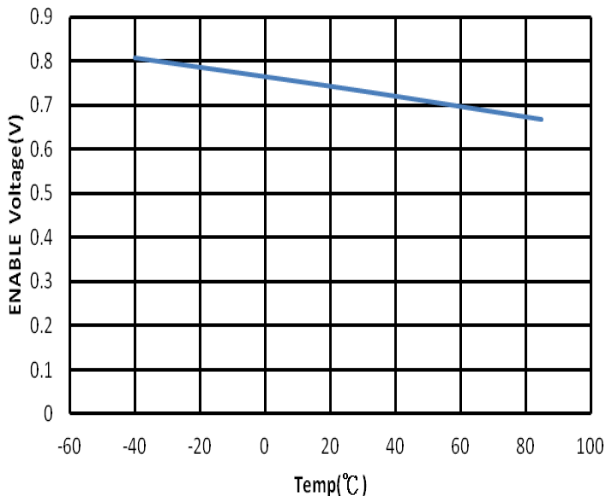

Fault Blanking Time VS Input Voltage

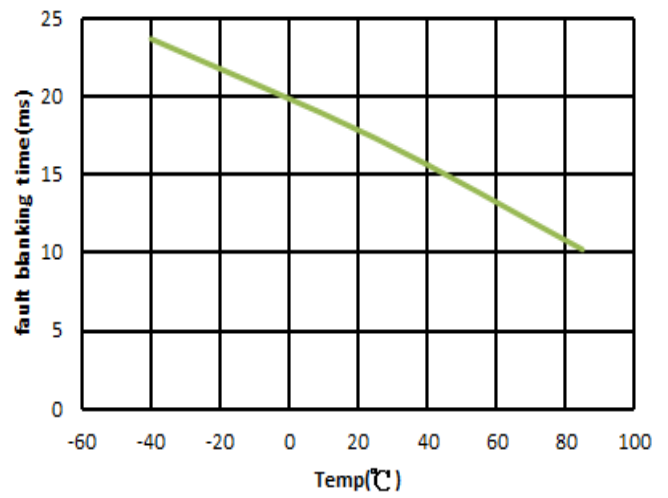

Output Rising Time VS Temperature

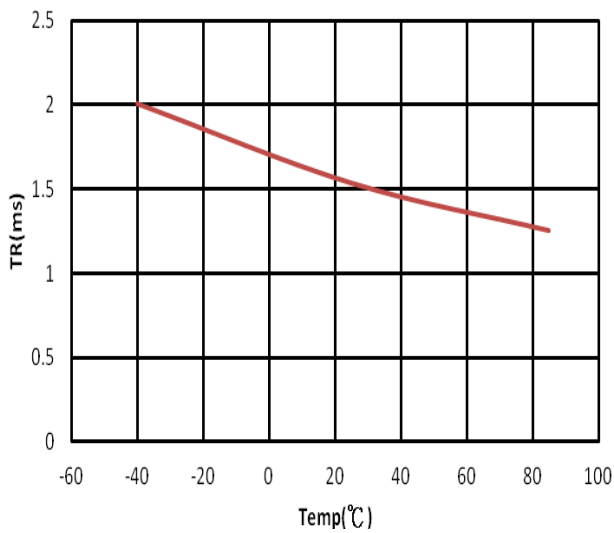

Over Current Protection VS Temperature

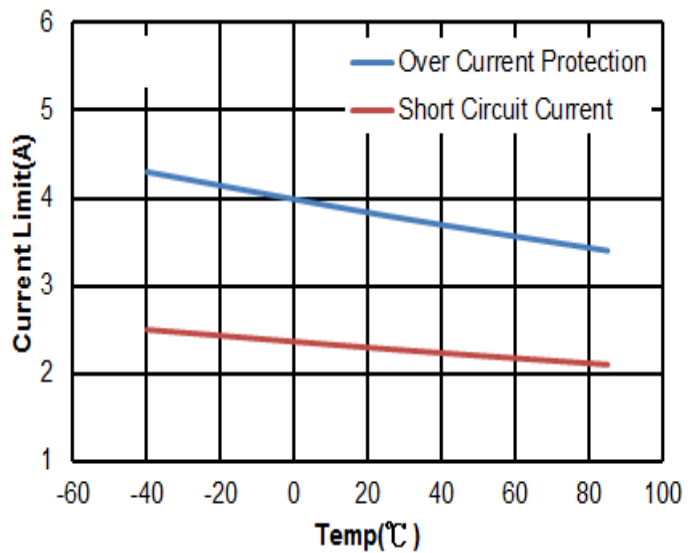

Ordering & Marking Information

Device Name: EM5203AN-20 for MSOP-8

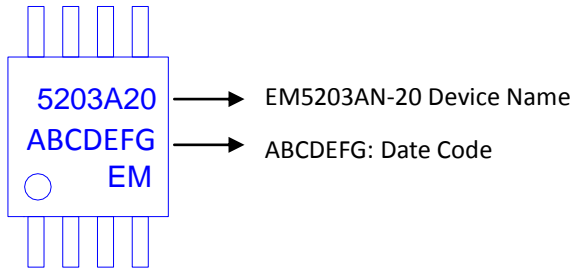

Device Name: EM5203N-20 for MSOP-8

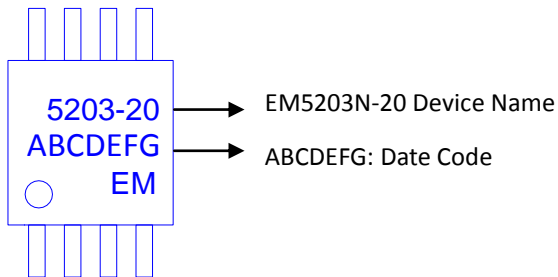

Outline Drawing

MSOP-8

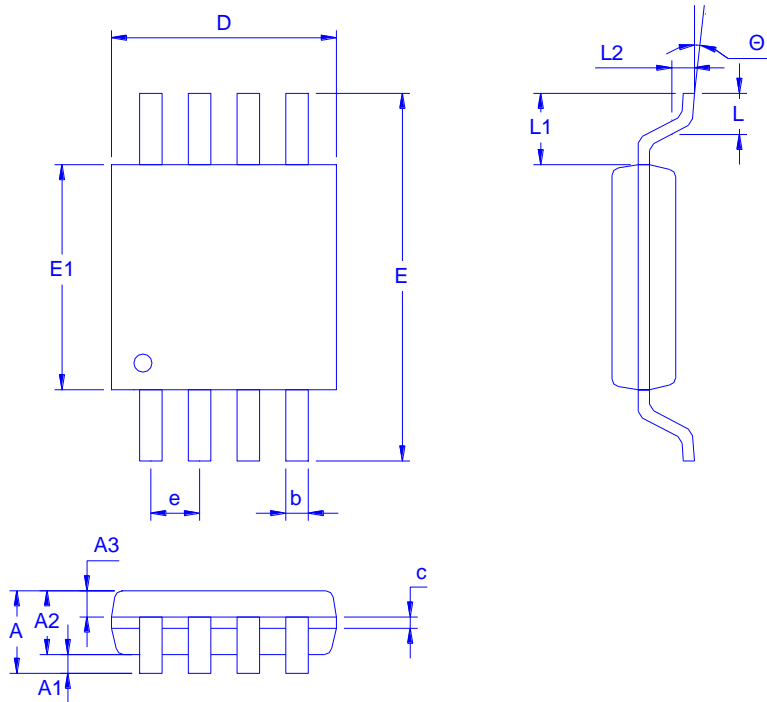

Dimension in mm

Dimension	A	A1	A2	A3	b	c	D	E	E1	e	L	L1	L2	Θ
Min.		0	0.75	0.25	0.25	0.15	2.9	4.7	2.9	0.55	0.4			0°
Typ.			0.85				3	4.9	3	0.65	0.6	0.95	0.25	
Max.	1.1	0.15	0.95	0.40	0.38	0.2	3.1	5.1	3.1	0.75	0.8			8°

Recommended minimum pads

