

12A 5V/12V Step-Down Converter

General Description

EM5812/A is a synchronous rectified PWM controller with a built in high-side power MOSFET operating with 5V or 12V supply voltage. It achieves 10A continuous output current with excellent load and line regulation. This device operates at 200/300kHz and provides an optimal level of integration to reduce size and cost of the power supply.

This part includes internal soft start, internal compensation networks, over current protection, under voltage protection, and shutdown function. This part is available in SOP-8 package.

Ordering Information

Part Number	Package	Frequency
EM5812GE	SOP-8 EP	200kHz
EM5812AGE	SOP-8 EP	300kHz

Features

- Operate from 5V to 12V Voltage Supply
- 15mΩ Internal Power MOSFET Switch
- 0.6V V_{REF} with 1.5% Accuracy
- Voltage Mode PWM Control
- 200/300kHz Fixed Frequency Oscillator
- 0% to 80% Duty Cycle
- Internal Soft Start
- Over Current Protection
- Integrated Bootstrap Diode
- Adaptive Non-Overlapping Gate Driver
- Under Voltage Protection
- Over Voltage Protection

Applications

- Notebook & Netbook
- Graphic Cards & MB
- Low Voltage Logic Supplies



Pin Configuration

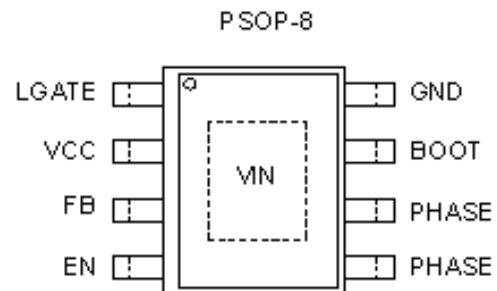

Typical Application Circuit

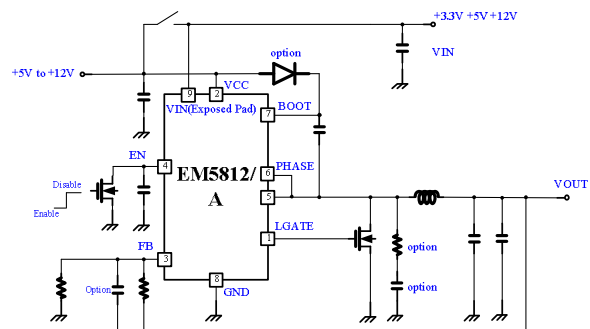

Pin Assignment

Pin Name	Pin No.	Pin Function
LGATE	1	Lower Gate Driver Output. Connect this pin to the gate of lower MOSFET. This pin is monitored by the adaptive shoot-through protection circuitry to determine when the lower MOSFET has turn off.
VCC	2	Bias Supply Voltage. This pin provides the bias supply for the EM5812/A and the lower gate driver. The supply voltage is internally regulated to 5VDD for internal control circuit. Connect a well-decoupled 4.5V to 13.2V supply voltage to this pin. Ensure that a decoupling capacitor is placed near the IC.
FB	3	Feedback Voltage. This pin is the inverting input to the error amplifier. A resistor divider from the output to GND is used to set the regulation voltage.
EN	4	Enable Pin. Pulling this pin lower than 0.3V disables the controller and causes the oscillator to stop.
PHASE	5,6	PHASE Switch Node. Connect this pin to the drain of the low-side MOSFET. This pin is used as the source for the high-side MOSFET, and to monitor the voltage drop across the low-side MOSFET for over current protection. This pin is also monitored by the adaptive shoot-through protection circuitry to determine when the high-side MOSFET has turned off. A Schottky diode between this pin and ground is recommended to reduce negative transient voltage which is common in a power supply system.
VIN	EP	Input Supply Voltage. This supplies power to the high-side MOSFET.
BOOT	7	Bootstrap Supply for the floating upper gate driver. Connect the bootstrap capacitor C_{BOOT} between BOOT pin and the PHASE pin to form a bootstrap circuit. The bootstrap capacitor provides the charge to turn on the upper MOSFET. Typical values for C_{BOOT} range from 0.1uF to 0.47uF. Ensure that C_{BOOT} is placed near the IC.
GND	8	Signal and Power Ground for the IC. All voltages levels are measured with respect to this pin. Tie this pin to the ground island/plane through the lowest impedance connection available.

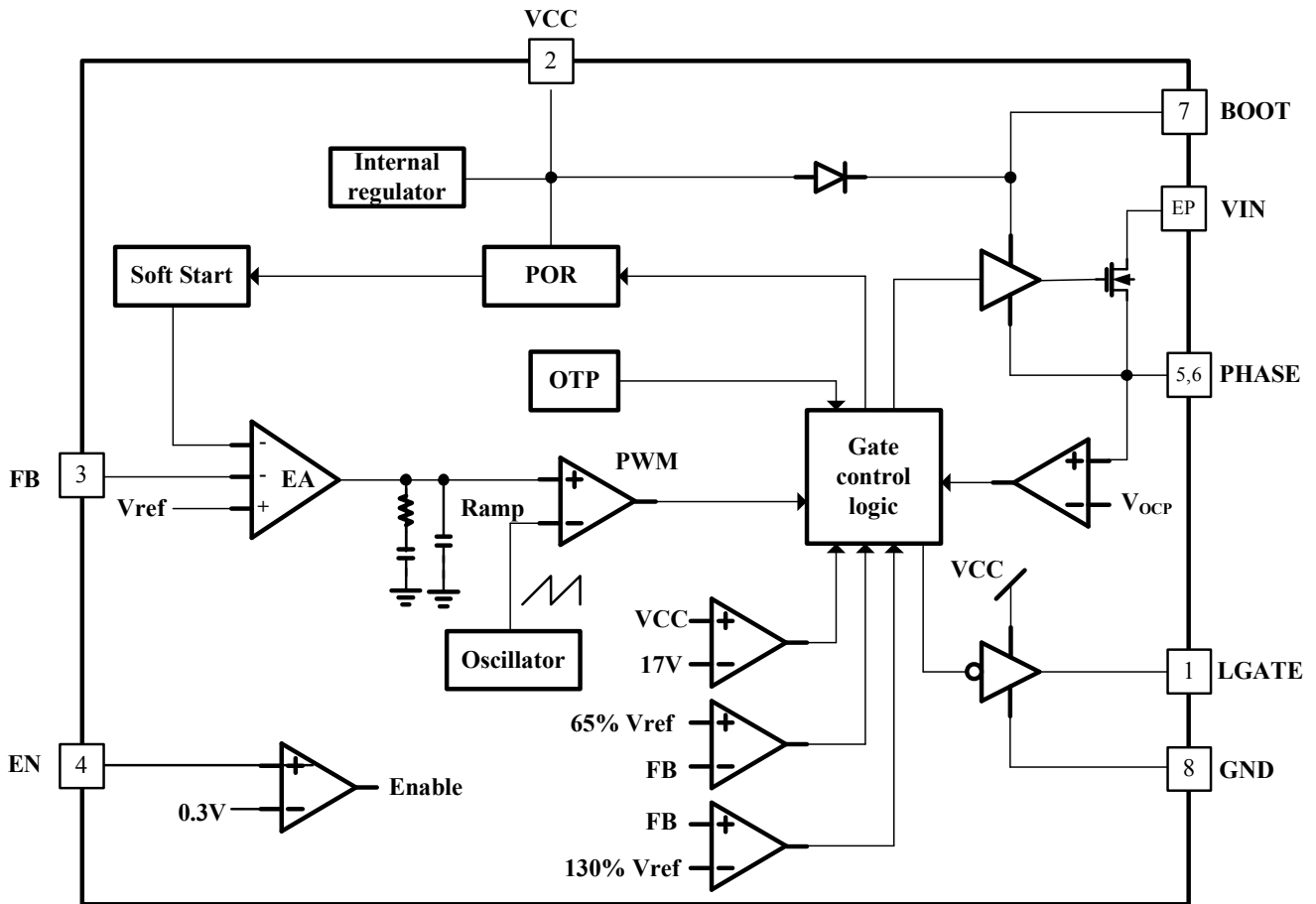

Absolute Maximum Ratings (Note 1)

● Supply voltage, VCC-----	-0.3V to 16V
● Supply voltage, VIN-----	-0.3V to 16V
● PHASE to GND	
DC-----	-5V to 16V
<200ns-----	-10V to 32V
● BOOT to PHASE-----	16V
● BOOT to GND	
DC-----	-0.3V to PHASE+16V
<200ns-----	-0.3V to 42V
● LGATE	
DC-----	-0.3V to VCC + 0.3V
<200ns-----	-5V to VCC+5V
● EN & FB-----	-0.3V to 6V
● Power Dissipation, PD @ TA = 25°C,	
PSOP-8 -----	1.33W
● Package Thermal Resistance, Θ_{JA} ,	
PSOP-8 (Note 2)-----	75°C/W
● Junction Temperature-----	150°C
● Lead Temperature (Soldering, 10 sec.)-----	260°C
● Storage Temperature Range-----	-65°C to 150°C
● ESD susceptibility (Note3)	
HBM (Human Body Mode)-----	2KV
MM (Machine Mode)-----	200V

Recommended Operating Conditions (Note4)

● Supply Voltage, V _{CC} -----	4.5V to 13.2V
● Supply Voltage, V _{IN} -----	2.5V to 13.2V
● Junction Temperature -----	-40°C to 125°C
● Ambient Temperature -----	-40°C to 85°C

Electrical Characteristics
 $V_{CC}=12V, T_A=25^{\circ}C$, unless otherwise specified

Parameter	Symbol	Test Conditions	Min	Typ	Max	Units
V_{CC} Supply Section						
V _{CC} Supply Voltage	V _{CC}		4.5		13.2	V
Supply Current	I _{CC}	LGATE open, Switching.		10		mA
Quiescent Supply Current	I _{CCQ}	No Switching.		2		mA
V _{CC} Power on Reset Threshold	V _{CCRTH}		4	4.2	4.4	V
V _{CC} Power on Reset Hysteresis	V _{CCHYS}			0.2		V
V_{IN} Supply Section						
V _{IN} Power on Reset Threshold	V _{INTH}			1.5		V
Internal Oscillator						
Free Running Frequency	F _{SW}	EM5812	170	200	230	KHz
		EM5812A	255	300	345	KHz
Ramp Amplitude	ΔV_{OSC}			1		V _{p-p}
Error Amplifier						
Open Loop DC Gain	A _O	Guaranteed by Design	55	70		dB
Gain-Bandwidth Product	GBW	Guaranteed by Design		10		MHz
Slew Rate	SR	Guaranteed by Design	3	6		V/us
Trans-conductance	g _m	Guaranteed by Design		0.2	0.7	mS
PWM Controller Gate Drivers						
Lower Gate Sourcing Current	I _{LG_SRC}	V _{CC} - V _{LGATE} = 6V		-1		A
Lower Gate Sinking Current	I _{LG_SNK}	V _{LGATE} = 6V		1.5		A
Lower Gate R _{DS(ON)} Sinking	R _{LG_SNK}	V _{LGATE} = 0.1V		2	4	Ω
PHASE Falling to LGATE Rising Delay		V _{CC} = 12V; V _{PHASE} < 1.2V to V _{LGATE} > 1.2V		30	90	ns
LGATE Falling to PHASE Rising Delay		V _{CC} = 12V; V _{LGATE} < 1.2V to V _{PHASE} > 1.2V		30	90	ns
High-Side MOSFET						
Switch ON Resistance	R _{DS(ON)}	V _{CC} = 12V			18	mΩ
Reference Voltage						
Nominal Feedback Voltage	V _{FB}		0.591	0.6	0.609	V
Enable Voltage						
EN Enable Threshold	V _{EN}			0.3	0.35	V
Protection section						
FB Under Voltage Protection	V _{FB_UVP}	FB falling	55	65	75	%
FB Over Voltage Protection	V _{FB_OVP}	FB rising	115	130	145	%
VCC Over Voltage Protection	V _{CC_OVP}		16	17	18	V
Over Current Threshold	V _{OCP}		-425	-375	-325	mV
Soft-Start Interval	T _{SS}		2.4	3.6	5.4	ms
Temperature Shutdown	T _{SD}	Guaranteed by Design	150	165		°C

Note 1. Stresses listed as the above "Absolute Maximum Ratings" may cause permanent damage to the device. These are for stress ratings. Functional operation of the device at these or any other conditions beyond those indicated in the operational sections of the specifications is not implied. Exposure to absolute maximum rating conditions for extended periods may remain possibility to affect device reliability.

Note 2. θ_{JA} is measured in the natural convection at TA = 25°C on a low effective thermal conductivity test board of JEDEC 51-3 thermal measurement standard.

Note 3. Devices are ESD sensitive. Handling precaution is recommended.

Note 4. The device is not guaranteed to function outside its operating conditions.

Power On Waveform

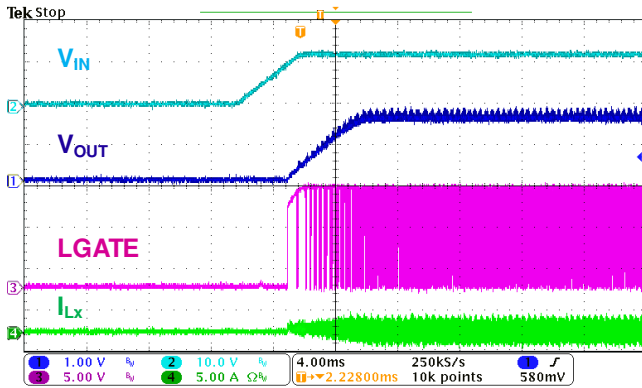

$V_{IN}=12V$, $V_{OUT}=1.5V$, $C_{OUT}=1000\mu F$, No Load.

Turn On from EN

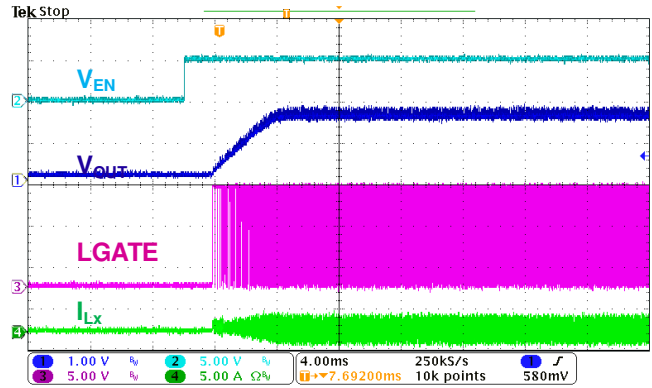

$V_{IN}=12V$, $V_{OUT}=1.5V$, $C_{OUT}=1000\mu F$, No Load.

Turn Off from EN

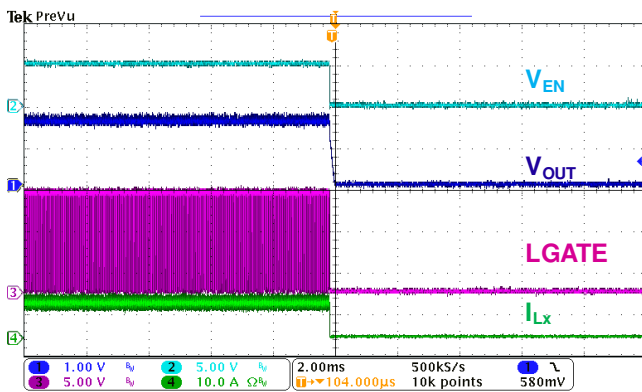

$V_{IN}=12V$, $V_{OUT}=1.5V$, $C_{OUT}=1000\mu F$, $I_{OUT}=8A$.

Load Transient Response (Turn on)

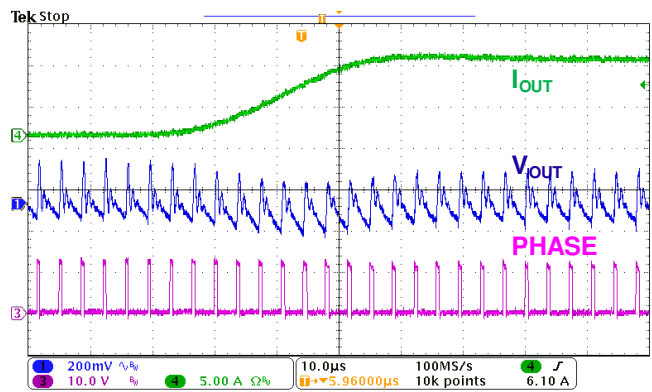

$V_{IN}=12V$, $V_{OUT}=1.5V$, $C_{OUT}=1000\mu F$, Load=0~9A

Load Transient Response (Turn off)

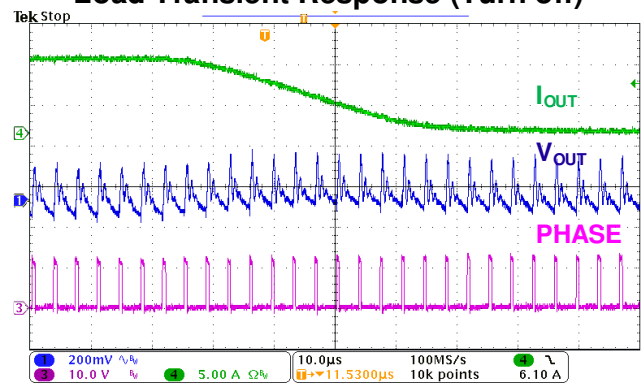

$V_{IN}=12V$, $V_{OUT}=1.5V$, $C_{OUT}=1000\mu F$,
Load=0~9A

Over Current Protection

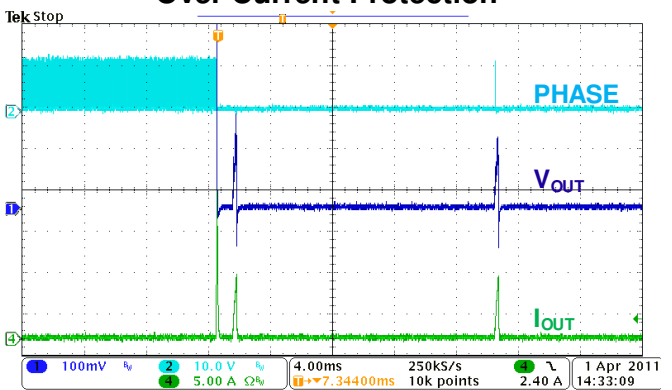

$V_{IN}=12V$, $V_{OUT}=1.5$, $C_{OUT}=1000\mu F$.
Output Short Ground

Over Current Protection

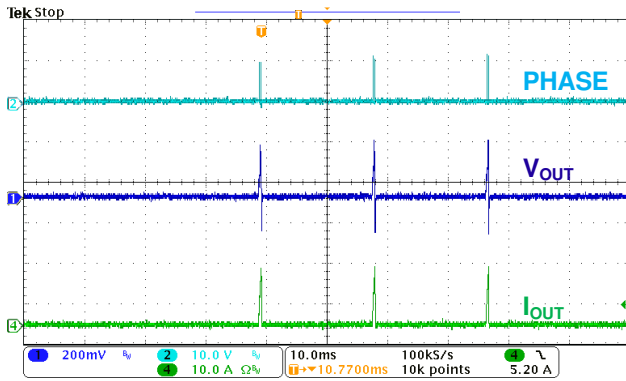

$V_{IN}=12V$, $V_{OUT}=1.5$, $C_{OUT}=1000\mu F$.
 Turn On to Short Circuit

Load Regulation

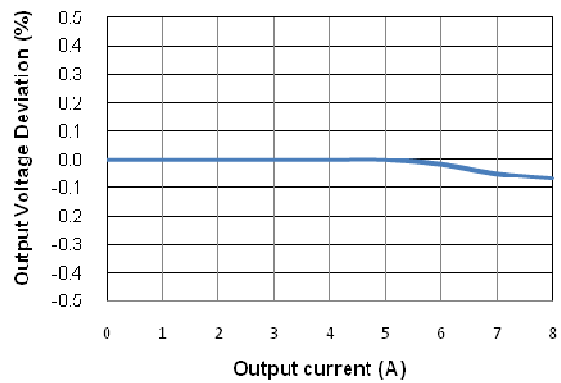

Line Regulation

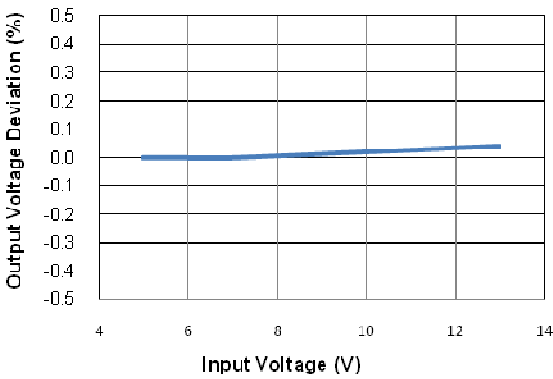

Switching Frequency vs. Input Voltage

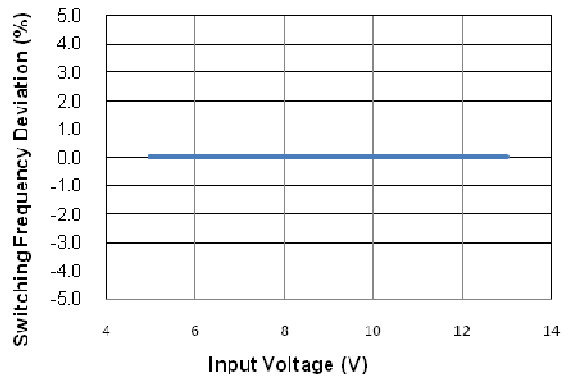

Efficiency VS Output Current

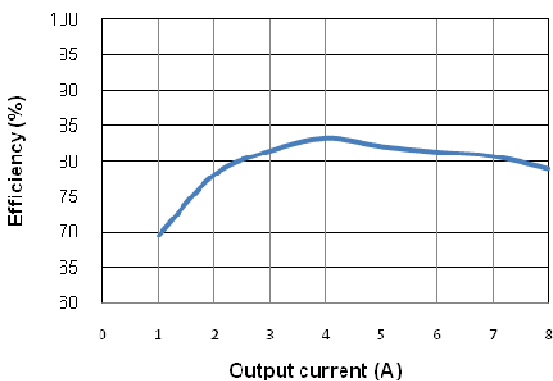

Temperature VS Output Current

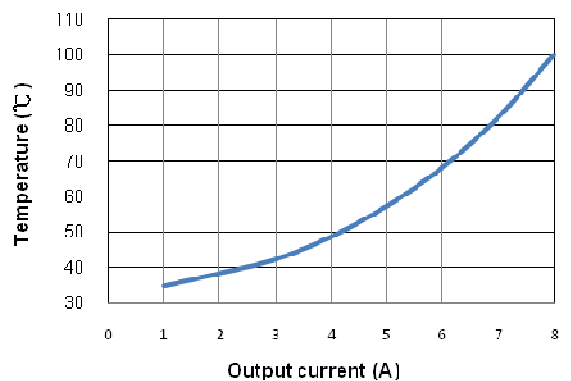

Functional Description

EM5812/A is a voltage mode synchronous buck PWM controller. The compensation circuit is implemented internally to minimize the external component count. This device provides complete protection function such as over current protection, under voltage protection and over voltage protection.

Supply Voltage

The V_{CC} pin provides the bias supply of EM5812/A control circuit, as well as lower MOSFET's gate and the BOOT voltage for the upper MOSFET's gate. A minimum 0.1uF ceramic capacitor is recommended to bypass the supply voltage.

Power ON Reset

To let EM5812/A start to operation, V_{CC} voltage must be higher than its POR voltage even when EN voltage is pulled higher than enable high voltage. Typical POR voltage is 4.2V.

Enable

To let EM5812/A start to operation, EN voltage must be higher than its enable voltage. Typical enable voltage is 0.3V.

Soft Start

EM5812/A provides soft start function internally. The FB voltage will track the internal soft start signal, which ramps up from zero during soft start period.

OCP, Over Current Protection

The over current function protects the converter from a shorted output by using lower MOSFET's on-resistance to monitor the current. The OCP level can be calculated as the following equation:

$$I_{OCP} = -\frac{V_{OCP}}{R_{DS(ON)}}$$

When OCP is triggered, EM5812/A will shut down the converter and cycles the soft start function in a hiccup mode. If over current condition still exist after 3 times of hiccup, EM5812/A will shut down the controller and latch.

UVP, Under Voltage Protection

The FB voltage is monitored for under voltage protection. The UVP threshold is typical 0.4V. When UVP is triggered, EM5812/A will shut down the converter and cycles the soft start function in a hiccup mode.

OVP, Over Voltage Protection

The FB voltage is monitored for over voltage protection. The OVP threshold is typical 0.8V. When OVP is triggered, EM5812/A will turn off upper MOSFET and turn on lower MOSFET.

Output Inductor Selection

The output inductor is selected to meet the output voltage ripple requirements and minimize the response time to the load transient. The inductor value determines the current ripple and voltage ripple. The ripple current is approximately the following equation:

$$\Delta I_L = \frac{V_{IN} - V_{OUT}}{L} * \frac{V_{OUT}}{V_{IN} * F_{SW}}$$

Output Capacitor Selection

An output capacitor is required to filter the output and supply the load transient. The selection of output capacitor depends on the output ripple voltage. The output ripple voltage is approximately bounded by the following equation:

$$\Delta V_{OUT} = \Delta I_L * (ESR + \frac{1}{8 * F_{SW} * C_{OUT}})$$

Input Capacitor Selection

Use a mix of input bypass capacitors to control the voltage overshoot across the MOSFET. Use small ceramic capacitors for high frequency decoupling and bulk capacitors to supply the current needed each time the upper MOSFET turn on. Place the small ceramic capacitors physically close to the MOSFETs and between the drain of the upper MOSFET and the source of the lower MOSFET. The important parameters of the input capacitor are the voltage rating and the RMS current rating. The capacitor voltage rating should be at least 1.25 times greater than the maximum input voltage and a voltage rating of 1.5 times is a conservative guideline. The RMS current rating requirement can be expressed as the following equation:

$$I_{RMS} = I_{OUT} \sqrt{D(1-D)}$$

For a through hole design, several electrolytic capacitors may be needed. For surface mount designs, solid tantalum capacitors can also be used but caution must be exercised with regard to the capacitor surge current rating. These capacitors must be capable of handling the surge current at power-up. Some capacitor series available from reputable manufacturers are surge current tested.

EM5812/A

Power MOSFET Selection

The EM5812/A requires a low-side N-Channel power MOSFETs. These should be selected based upon on-resistance, breakdown voltage, gate supply requirement, and thermal management requirements.

In high current applications, the MOSFET power dissipation, package selection and heat sink are the dominate design factor. The power dissipation includes two loss components: conduction loss and switching loss. The conduction losses are the largest component of power dissipation for both the upper and lower MOSFETs. These losses are distributed between the two MOSFETs according to duty factor.

The power dissipations in the two MOSFETs are approximately the following equation:

$$PD_{UPPER} = I_{OUT}^2 * R_{DS(ON)} * D + 0.5 * I_{OUT} * V_{IN} * F_{SW} * t_{SW}$$

$$PD_{LOWER} = I_{OUT}^2 * R_{DS(ON)} * (1-D)$$

Where D is the duty cycle, t_{SW} is the combined switch ON and OFF time.

Ordering & Marking Information

Device Name: EM5812GE for SOP-8 EP

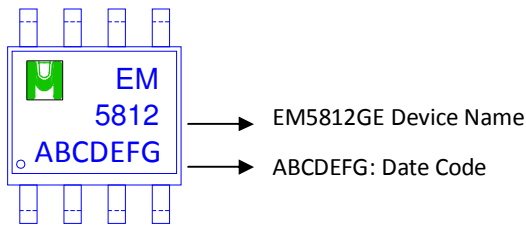

Device Name: EM5812AGE for SOP-8 EP

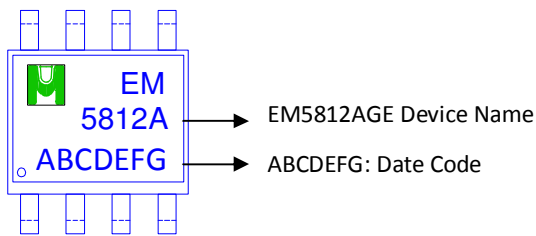

Outline Drawing

SOP-8 EP

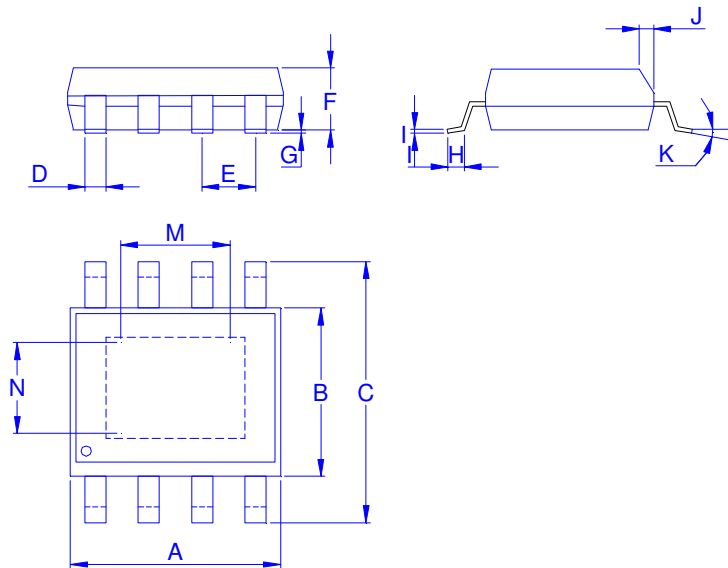

Dimension in mm

Dimension	A	B	C	D	E	F	G	H	I	J	K	M	N
Min.	4.70	3.70	5.80	0.33		1.20	0.08	0.40	0.19	0.25	0°	3.2	2.21
Typ.					1.27								
Max.	5.10	4.10	6.20	0.51		1.62	0.28	0.83	0.26	0.50	8°	3.6	2.61