

Product Specification

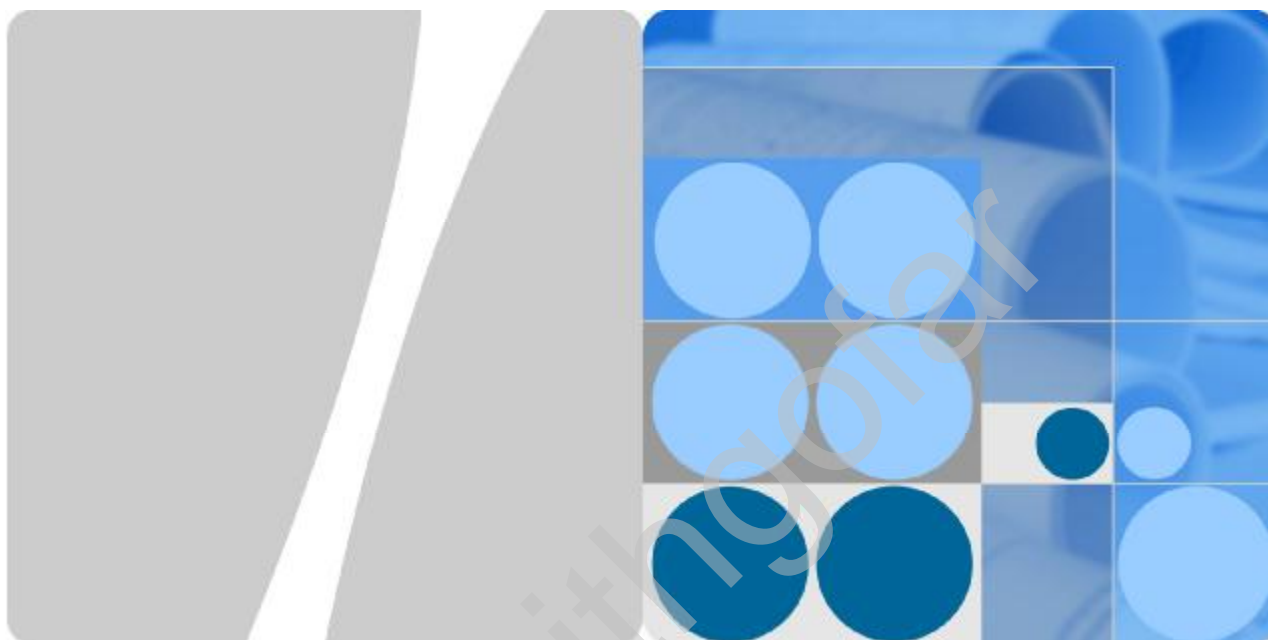

HUAWEI EM770 HSPA PC Embedded Module

V100R001

Issue 01
Date 2008-09-15



HUAWEI TECHNOLOGIES CO., LTD.

Huawei Technologies Co., Ltd. provides customers with comprehensive technical support and service. Please feel free to contact our local office or company headquarters.

Huawei Technologies Co., Ltd.

Address: Huawei Industrial Base
Bantian, Longgang
Shenzhen 518129
People's Republic of China

Website: <http://www.huawei.com>

Email: support@huawei.com

Copyright © Huawei Technologies Co., Ltd. 2008. All rights reserved.

No part of this document may be reproduced or transmitted in any form or by any means without prior written consent of Huawei Technologies Co., Ltd.

Trademarks and Permissions



and other Huawei trademarks are trademarks of Huawei Technologies Co., Ltd.

All other trademarks and trade names mentioned in this document are the property of their respective holders.

Notice

The information in this document is subject to change without notice. Every effort has been made in the preparation of this document to ensure accuracy of the contents, but all statements, information, and recommendations in this document do not constitute the warranty of any kind, express or implied.

About This Document

Summary

This document provides information about the major functions, supported services, system architecture, and technical references of HUAWEI EM770 HSPA PC Embedded Module.

The following table lists the contents of this document.

Chapter	Details
1 Overview	Describes the basic functions, key features, and hardware and software overview of the EM770.
2 Mechanical Specifications	Describes the mechanical specifications of the EM770.
3 Electrical Specifications	Describes the electrical specifications of the EM770.
4 RF Specifications	Describes the RF specifications of the EM770.
5 Software and Tools	Describes the software and tools of the EM770.
6. Technical Reference	Describes the technical references of the EM770.
A Acronyms and Abbreviations	Lists the acronyms and abbreviations mentioned in this document.



History

Issue	Details	Date	Author	Approved By
01	Creation	2008-09-15	Tan Xiao'an	Xie Conglong

for faithgofar

Contents

1 Overview	7
1.1 Introduction	7
1.2 Key Features.....	8
1.3 Hardware Overview.....	9
1.3.1 Hardware Logic Block Diagram	9
1.3.2 External Hardware Interfaces.....	10
1.4 Software Overview	12
2 Mechanical Specifications.....	14
2.1 Dimensions and interfaces.....	14
2.1.1 Dimensions and interfaces of the EM770	14
2.1.2 Dimensions of the Mini PCI Express Connector.....	15
2.1.3 Dimensions of the Antenna Connector.....	16
2.2 Reliability.....	18
2.3 Temperature	18
3 Electrical Specifications	19
3.1 Mini PCI Express Pin Definition	19
3.2 Pin Descriptions	22
3.2.1 Digital Signal DC Characteristics.....	22
3.2.2 Power Sources and Grounds	23
3.2.3 USB Signals.....	23
3.2.4 USIM Signals.....	23
3.2.5 W_DISABLE# Signal.....	26
3.2.6 LED_WWAN# Signal.....	27
3.2.7 PERST# Signal.....	28
3.2.8 NC Pins	29
3.3 Power Supply and Consumption.....	29
4 RF Specifications	32
4.1 Operating Frequencies	32
4.2 Conducted Rx sensitivity and Tx power	32
4.3 Antenna Design Requirements	33
4.3.1 Recommended Index of the Module Antennas.....	33
4.3.2 Design Recommendations	34



4.4 Offline Mode.....	35
5 Software and Tools	36
5.1 Firmware	36
5.1.1 Version Descriptions	36
5.2 Drivers	36
5.2.1 Windows Drivers.....	37
5.2.2 Linux Drivers.....	37
5.3 Dashboard	38
5.3.1 Windows Dashboard.....	38
5.3.2 Linux Dashboard.....	40
5.4 Tools	40
5.4.1 Firmware Update Tool	40
5.4.2 Module Label Print Tool-MLT	44
5.4.3 Engineering Tools	54
5.4.4 Debugging Board.....	54
6 Technical Reference.....	61
6.1 Layer 1 Specifications (Physical)	61
6.2 Layer 2 Specifications (MAC/RLC).....	61
6.3 Layer 3 Specifications (RRC).....	61
6.4 Layer 3 NAS/Core Network (MM/CM)	61
6.5 GSM Protocol Specifications.....	62
6.6 GPRS Protocol Specifications.....	62
6.7 General Specifications.....	62
6.8 Performance/Test Specifications.....	63
6.9 SIM Specifications.....	63

1 Overview

1.1 Introduction

HUAWEI EM770 HSPA PC Embedded Module (hereinafter referred to as the EM770) is a high-speed packet access (HSPA) Wireless Wide Area Network (WWAN) PC module. It is a multi-mode wireless terminal for business professionals.

The EM770 supports the following standards:

- | HSDPA/HSUPA
- | Universal Mobile Telecommunications System (UMTS)
- | Enhanced Data Rates for Global Evolution (EDGE)
- | General Packet Radio Service (GPRS)
- | Global System for Mobile Communications (GSM)

The EM770 provides the following services:

- | HSPA/UMTS packet data service
- | EDGE/GPRS packet data service
- | WCDMA/GSM short message service (SMS)

The EM770 can be connected to a PC via the Mini PCI Express interface. In the service area of the HSPA, UMTS, EDGE, GPRS or GSM network, you can surf the Internet, send messages and emails, and receive messages/emails cordlessly. The EM770 is fast, reliable, and easy to operate. Thus, mobile users can experience many new features and services with the EM770. These features and services will enable a large number of users to use the EM770 and the average revenue per user (ARPU) of operators will increase substantially.

Figure 1-1 shows the profile of the EM770.

Figure 1-1 Profile of the EM770



1.2 Key Features

Table 1-1 lists the key features of the EM770.

Table 1-1 Key features of the EM770

	EM770
HSPA/UMTS 2100 MHz	√
HSPA/UMTS 1900 MHz	√
HSPA/UMTS 1700 MHz	
HSPA/UMTS 900 MHz	
HSPA/UMTS 850 MHz	√
HSPA/UMTS 800 MHz	
GSM/GPRS/EDGE 850/900/1800/1900 MHz	√
HSPA equalizer and receive diversity	√
HSPA data service of DPA 7.2Mbit/s and UPA 2Mbit/s(5.76Mbit/s ready)	√
UMTS PS domain data service of up to 384 kbps	√
EDGE packet data service of up to 236.8 kbps	√
GPRS packet data service of up to 85.6 kbps	√

	EM770
CS domain data service based on UMTS and GSM	√
SMS based on the CS/PS domain of GSM and WCDMA	√
USSD	√
Personal computer/Smart card (PC/SC) driver	√
Mini PCI Express 1.2 interface	√
Windows 2000/Windows XP/Windows Vista/Linux 2.6.18 or later versions	√

1.3 Hardware Overview

The hardware of the EM770 consists of three sections: baseband section, power management (PM) section, and radio frequency (RF) section. External interfaces include the antenna interface and the Mini PCI Express interface.

1.3.1 Hardware Logic Block Diagram

The EM770 is completed on a single-board. Figure 1-2 shows the hardware functional block diagram.

Figure 1-2 Hardware functional block diagram

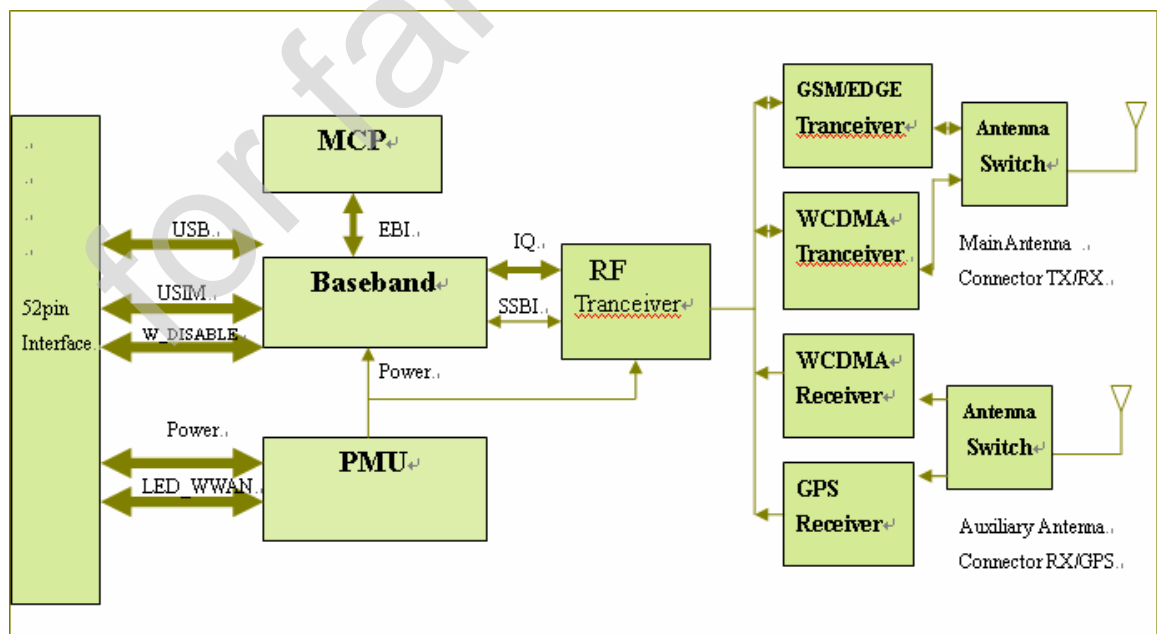

The circuitry of the EM770 consists of three sections: baseband section, RF section, and PM section.

- | The baseband section includes the baseband processor and SDRAM/flash MCP. It implements baseband signals processing, wireless protocols, and management of various peripheral devices.
- | The RF section includes the RF transceiver, PA, antenna switches, duplexer, and antenna interfaces, and it supports receive diversity.
- | The PMU section includes PM IC and DC-DC circuits, providing the power supply and power management for the whole module.
- | The GPS section is optional.

1.3.2 External Hardware Interfaces

1. Antenna interface

The EM770 has a main antenna connector and an auxiliary antenna connector.

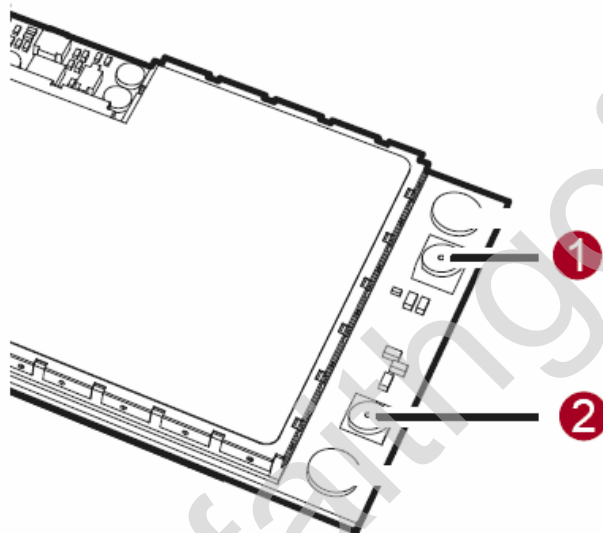

- ❶ Auxiliary antenna connector (labeled with **A** on the PCB)
- ❷ Main antenna connector (labeled with **M** on the PCB)

2. Mini PCI Express interface

The interface of the EM770 is a standard Mini PCI Express interface. The EM770 consists of several major signals, as shown in the following figure.

Figure 1-3 Mini PCI Express identification

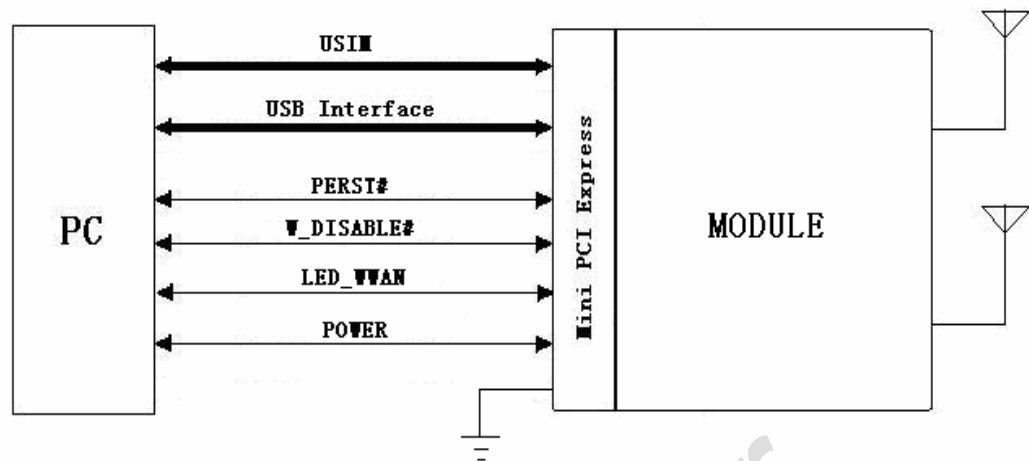

- USIM interface: The USIM interface provides the interface for a USIM card. The USIM card can be inserted into the PC.
- USB interface: The USB interface supports three modes of USB 2.0 (low speed, full speed, and high speed). Because there is not a separate USB-controlled voltage bus, USB functions implemented on EM770 which are expected to report as self-powered devices.
- Auxiliary signals: The auxiliary signals provide some other functions.
- Power sources and grounds: The PCI Express Mini Card provides two power sources, including the one at 3.3 V_{aux} (3.3V_{aux}) and the one at 1.5 V(+1.5 V). The EM770 uses the 3.3 voltage as the power supply.

1.4 Software Overview

Figure 1-4 Software logic block diagram

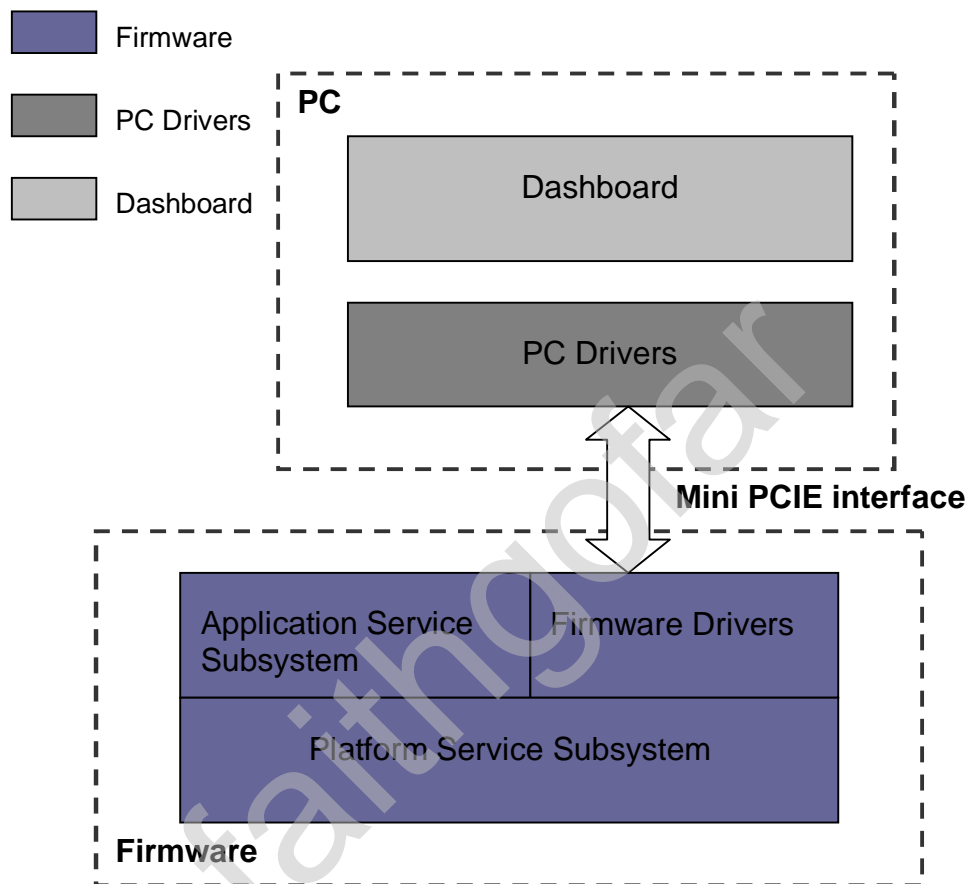

Descriptions of the functional modules in the system architecture are as follows.

Firmware Drivers

The firmware drivers include drivers of the RF module, flash, and all the peripherals such as the SIM card and USB device.

Platform Service Subsystem

The platform service subsystem initializes programs, diagnoses, downloads data, and serves as a watchdog.

Application Service Subsystem

The application service subsystem consists of various application services and a WCDMA-GSM dual mode protocol stack. Application services handle the commands and data sent from PC side according to service categories, and deliver them to

the protocol stack. The protocol stack communicates with the network side to process the commands and data, and returns response from network to application services. Finally, application services return responses to PC side.

The main application services are as follows:

- | Call management service
- | SMS service
- | CS/PS data service

PC Drivers

The PC drivers are used to implement functions such as the interaction between the dashboard and the firmware.

Dashboard

The dashboard enables the PC side to display the interfaces of initiating or answering a call, and sending and receiving messages. It provides the interface for CS/PS domain network accessing and periodically refreshes the interface of the current USB modem status. The interface is provided to the end users.

for faithgong

2 Mechanical Specifications

2.1 Dimensions and interfaces

2.1.1 Dimensions and interfaces of the EM770

The dimensions of the EM770 are 51 mm (length) × 30 mm (width) × 5 mm (height), which comply with the standard dimensions specified in the *PCI Express Mini Card Electromechanical Specification Revision 1.2*. Figure 2-1 shows the dimensions of the EM770 in details.

Figure 2-1 Dimensions of the EM770

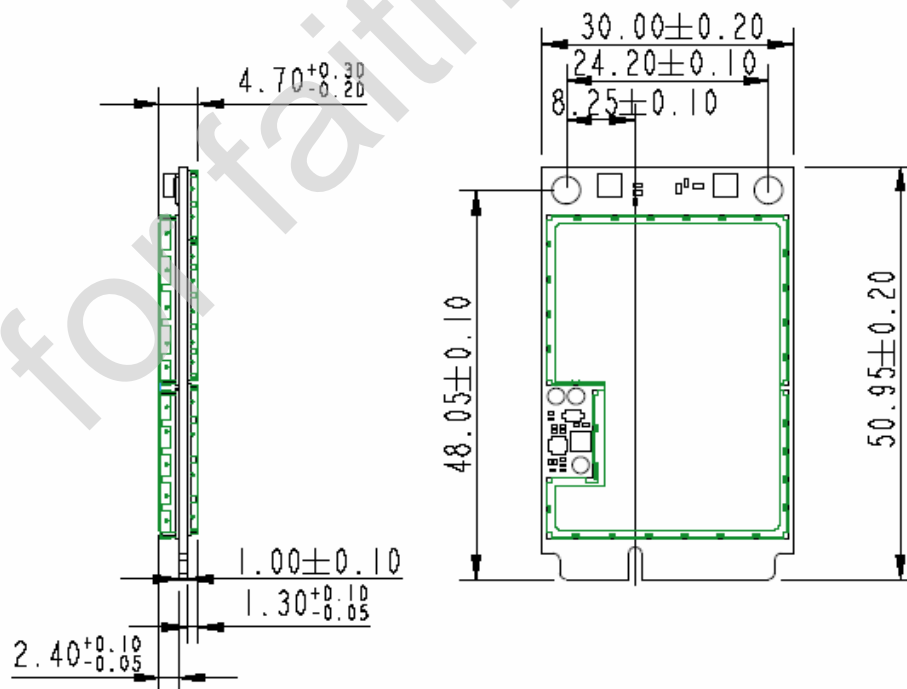
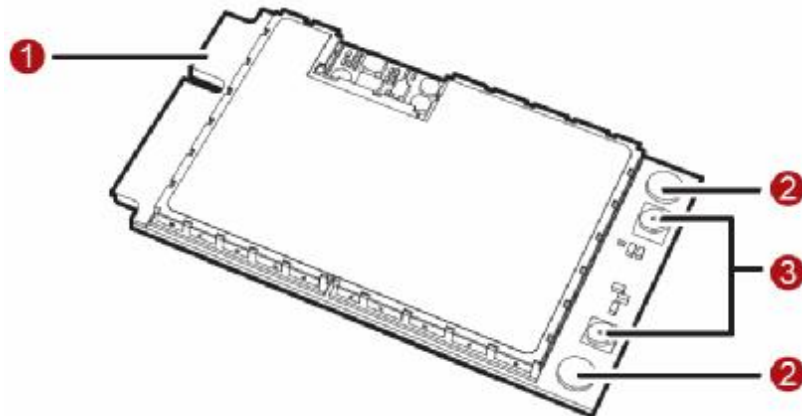

Figure 2-2 shows the appearance of the interfaces on the EM770.

Figure 2-2 Appearance of the interfaces on the EM770



① Mini PCI Express connector

It is used to connect the EM770 to the WWAN Mini PCI Express interface of the PC.

② Screw holes

They are used to fix the EM770 on the main board of the PC with screws.

③ Antenna interfaces

They are used to connect to antennas. Auxiliary antenna and main antenna are combined to support receive diversity. The receive diversity can strengthen the received RF signal quality and improve RF performance, and whether to open or close the receive diversity function can be controlled by software.

Note:

We strongly recommend adding auxiliary antenna when you design PC with the EM770.

2.1.2 Dimensions of the Mini PCI Express Connector

The EM770 adopts a standard Mini PCI Express connector that has 52 pins and complies with the *PCI Express Mini Card Electromechanical Specification Revision 1.2*.

Figure 2-3 shows a 52-pin Mini PCI Express connector (take the Molex 67910002 as an example).

Figure 2-3 Dimensions of the Mini PCI Express connector

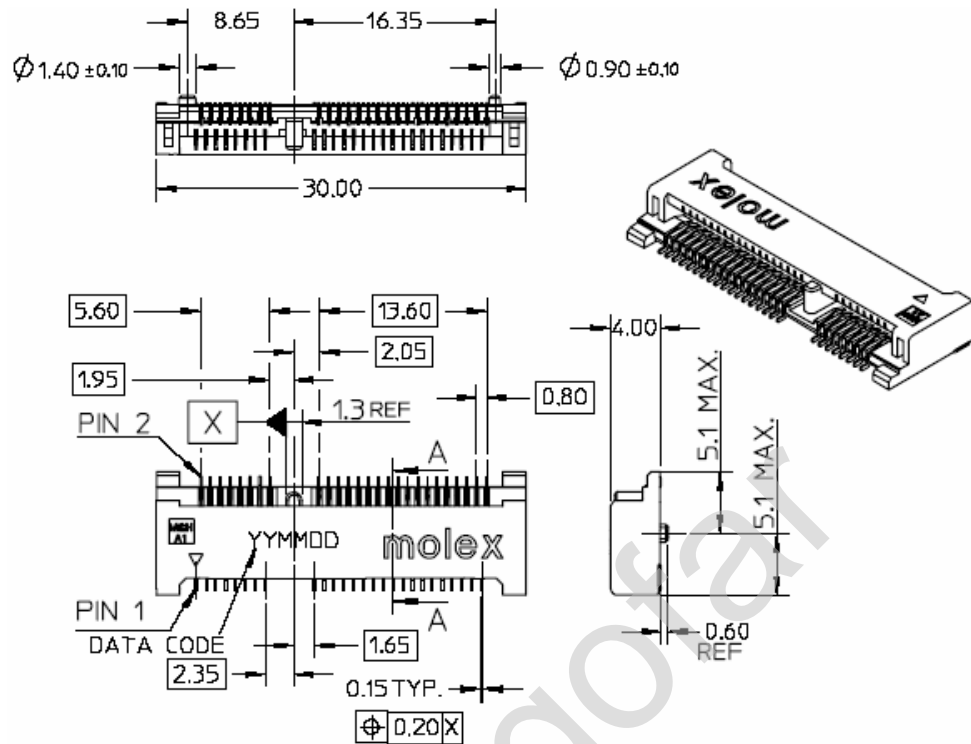

2.1.3 Dimensions of the Antenna Connector

The EM770 provides an interface for connecting an external antenna. The external antenna is connected to the module through the coaxial connector that is the Hirose U.FL-R-SMT-1(10) (you can get to know Hirose U.FL-R-SMT-1(10) by visiting the website http://www.hirose-connectors.com/products/U.FL_1.htm).

Figure 2-4 Dimensions of the antenna connector

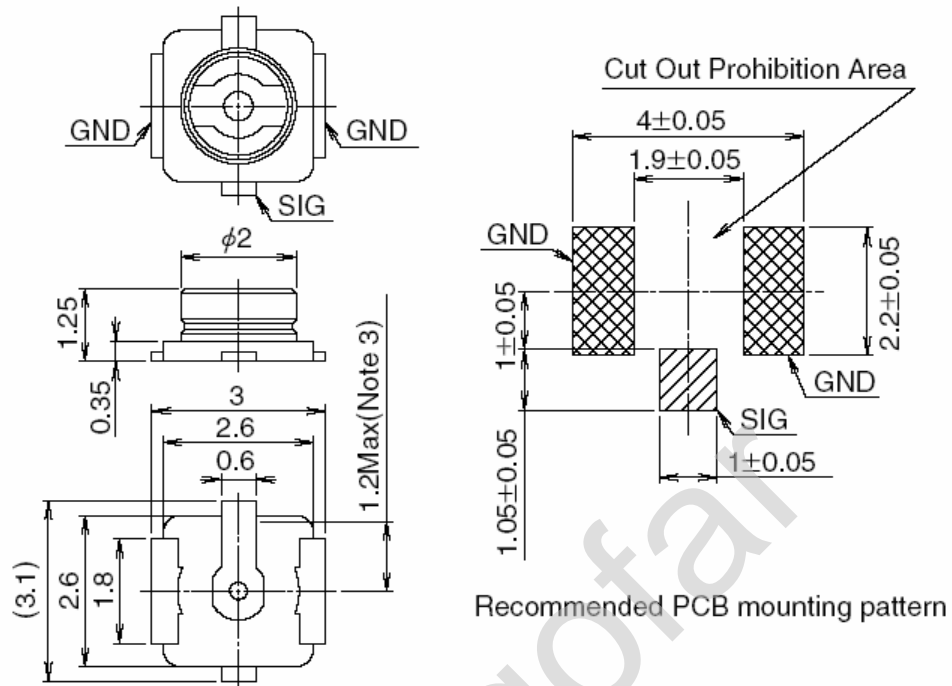

Figure 2-5 shows the specifications of the antenna mating connectors (take the ones with the Hirose part number as U.FL-LP as examples).

Figure 2-5 Specifications of the antenna mating connectors

Part No.	U.FL-LP-040	U.FL-LP-055	U.FL-LP(V)-040	U.FL-LP-062	U.FL-LP-088
Mated Height	2.5mm Max. (2.4mm Nom.)	2.5mm Max. (2.4mm Nom.)	2.0mm Max. (1.9mm Nom.)	2.4mm Max. (2.3mm Nom.)	2.4mm Max. (2.3mm Nom.)
Applicable cable	Dia. 0.81mm Coaxial cable	Dia. 1.13mm and Dia. 1.32mm Coaxial cable	Dia. 0.81mm Coaxial cable	Dia. 1mm Coaxial cable	Dia. 1.37mm Coaxial cable

For more information about Hirose Ltd., SMD connectors, and mating connectors, visit the website of Hirose <http://www.hirose-connectors.com>.

2.2 Reliability

Table 2-1 Requirements on the environment reliability

Test Case		Standard	
Environment reliability	Operational	High temperature	IEC60068-2-2
		High temperature	IEC60068-2-1
		Random vibration	MIL-STD-810F -METHOD 514.5
		Shock vibration	ANSI/TIA-603-C-2004 -3.3.5
		Sine sweep vibration	ANSI/TIA-603-C-2004 -3.3.4
	Non-operational	High temperature	IEC60068-2-2
		Low temperature	IEC60068-2-1
		Damp heat, cyclic	IEC60068-2-30
		Thermal shock	IEC60068-2-14
		Salt-fog	IEC60068-2-11
		Drop	IEC 60068-2-32
Durability	EIA-364-9		

2.3 Temperature

Description	Minimum	Maximum	Unit
Operating temperature	-10	+55	°C
Storage temperature	-40	+85	°C

3 Electrical Specifications

3.1 Mini PCI Express Pin Definition

The physical connections and signal levels of the EM770 comply with PCI Express Mini CEM specifications. Device operations comply with USB 2.0 specifications.

Table 3-1 lists the Mini PCI Express connector pins out of the EM770.

Table 3-1 Definition of mini PCI Express pins

Definition of the EM770 Mini PCI Express pins				
Pin No.	Mini PCI Express Standard Description	HUAWEI Pin Description	Additional Description	Direction to Module
1	WAKE#	NC	Not connected.	–
2	3.3Vaux	VCC_3V3	3.3 V DC supply rails from the PC side.	Input
3	COEX1	NC	Not connected.	–
4	GND	GND	Mini Card ground.	–
5	COEX2	NC	Not connected.	–
6	1.5 V	NC	Not connected.	–
7	CLKREQ#	Pull up	Pull up	–
8	UIM_PWR	UIM_PWR	Power source for the external UIM/SIM card.	Output
9	GND	GND	Mini Card ground.	–
10	UIM_DATA	UIM_DATA	External UIM/SIM data signal.	Input/Output
11	REFCLK-	NC	Not connected.	–
12	UIM_CLK	UIM_CLK	External UIM/SIM clock signal.	Output

Definition of the EM770 Mini PCI Express pins				
Pin No.	Mini PCI Express Standard Description	HUAWEI Pin Description	Additional Description	Direction to Module
13	REFCLK+	NC	Not connected.	–
14	UIM_RESET	UIM_RESET	External UIM/SIM reset signal.	Output
15	GND	GND	Mini Card ground.	–
16	UIM_Vpp	NC	Not connected.	–
17	Reserved	NC	Not connected.	–
18	GND	GND	Mini Card ground.	–
19	Reserved	NC	Not connected.	–
20	W_DISABLE#	W_DISABLE_N	For ending the wireless communications	Input
21	GND	GND	Mini Card ground.	–
22	PERST#	PERST#	For forcing a hardware reset on the card.	Input
23	PERn0	NC	Not connected.	–
24	3.3Vaux	NC	Not connected.	–
25	PERp0	NC	Not connected.	–
26	GND	GND	Mini Card ground.	–
27	GND	GND	Mini Card ground.	–
28	1.5 V	NC	Not connected.	–
29	GND	GND	Mini Card ground.	–
30	SMB_CLK	NC	Not connected.	–
31	PETn0	NC	Not connected.	–
32	SMB_DATA	NC	Not connected.	–
33	PETp0	NC	Not connected.	–
34	GND	GND	Mini Card ground.	–
35	GND	GND	Mini Card ground.	–
36	USB_D-	USB_D-	USB signal D-.	Input/Output
37	GND	GND	GND	–
38	USB_D+	USB_D+	USB signal D+.	Input/Output

Definition of the EM770 Mini PCI Express pins				
Pin No.	Mini PCI Express Standard Description	HUAWEI Pin Description	Additional Description	Direction to Module
39	3.3Vaux	VCC_3V3	3.3V DC supply rail from the PC side.	Input
40	CPUSB#	GND	GND	–
41	3.3Vaux	VCC_3V3	3.3V DC supply rail from the PC side.	Input
42	LED_WWAN#	LED_WWAN	Active-low LED signal for indicating the state of the card.	Output
43	GND	GND	GND	–
44	LED_WLAN#	NC	Not connected.	–
45	Reserved	NC	Not connected.	–
46	LED_WPAN#	NC	Not connected.	–
47	Reserved	NC	Not connected.	–
48	1.5 V	NC	Not connected	–
49	Reserved	NC	Not connected	–
50	GND	GND	Mini Card Ground	–
51	Reserved	NC	Not connected	–
52	3.3Vaux	VCC_3V3	3.3V DC supply rail from the PC side.	Input

3.2 Pin Descriptions

3.2.1 Digital Signal DC Characteristics

Table 3-2 Digital signal DC characteristics

Symbol	Description	Minimum	Maximum	Unit	Notes
V_{IH}	High-level input voltage, CMOS/Schmitt	$0.7 \cdot V_{DD_X}$	$V_{DD_X} + 0.3$	V	1
V_{IL}	Low-level input voltage, CMOS/Schmitt	-0.3	$0.3 \cdot V_{DD_X}$	V	1
V_{OH}	High-level output voltage, CMOS	$V_{DD_X} - 0.5$	V_{DD_X}	V	1
V_{OL}	Low-level output voltage, CMOS	0	0.4	V	1
I_{IH}	Input high leakage current	-	1	μA	1
I_{IL}	Input low leakage current	-1	-	μA	1
I_{IHPD}	Input high leakage current with pull-down	10	60	μA	1
I_{ILPU}	Input low leakage current with pull-up	-60	-10	μA	1
I_{OZH}	High-level, three-state leakage current	-	1	μA	1
I_{OZL}	Low-level, three-state leakage current	-1	-	μA	1
I_{OZHPD}	High-level, three-state leakage current with pull-down	10	60	μA	1
I_{OZLPU}	Low-level, three-state leakage current with pull-up	-60	-10	μA	1
C_{IN}	Input capacitance	-	7	pF	1, 2

Notes:

1. Table 3-2 lists the universal specifications of the signals. Any difference from the universal specifications is listed in the related chapter or section.
2. The input capacitance value is guaranteed by design and not completely tested.

3.2.2 Power Sources and Grounds

The PCI Express Mini Card provides two power sources: one is 3.3V_{aux} (3.3 V_{aux}) and the other is 1.5V (+ 1.5 V). For the EM770, +3.3V_{aux} is the only supply voltage available. The input voltage is 3.3 V ± 9%, as specified by PCI Express Mini CEM Specifications 1.2.

Table 3-3 Power and ground specifications

Name	Pins	Minimum	Type	Maximum
VCC	2, 39, 41, and 52	3.0 V	3.3 V	3.6 V
GND	4, 9, 15, 18, 21, 26, 27, 34, 35, 37, 43, and 50	0 V		

3.2.3 USB Signals

The EM770 is compliant with USB 2.0 specification. It supports full-speed and high-speed when acting as a peripheral and supports low-speed, full-speed, and high-speed when acting as a host. The USB 2.0 specifications allow peripherals to support any one or more of these speeds.

Table 3-4 USB pins

Name	Pin	Description	Direction to Module
USB D-	36	USB data signal D-	Input/Output
USB D+	38	USB data signal D+	Input/Output

The USB interface is powered directly from the 3.3 V supply. The USB input/output lines are compatible with the USB 2.0 3.3 V signal specifications.

Table 3-5 USB signal DC characteristics

V _{OHmin}	V _{OLmax}	V _{IHmin}	V _{ILmax}
2.8V	0.3V	2V	0.8V

3.2.4 USIM Signals

The USIM is a smart card for UMTS/GSM cellular applications. The USIM provides the required subscription information to allow the mobile equipment to attach to a GSM or UMTS network. The USIM also provides the subscriber's verification procedures as well as authentication methods for network authentication during the attach procedures.

Table 3-6 USIM pins

Pin	Name	Description	Direction to Module
8	UIM_PWR	Power source for the external UIM/SIM.	Output
10	UIM_DATA	External UIM/SIM data signal.	Input/Output
12	UIM_CLK	External UIM/SIM clock signal.	Output
14	UIM_RESET	External UIM/SIM reset signal.	Output
16	UIM_Vpp	Programming power connection used to program EEPROM of first generation ICCs, but not used now.	Not connected

Note:

It is recommended that the SIM card is inserted only after the power of the module is disconnected, otherwise the SIM card can be destroyed.

USIM interface schematic reference:

There is no SIM card interface circuit in the EM770 module, and users need to add the USIM interface circuit. The definition of interface signals and the typical USIM interface schematic are as follows.

Figure 3-1 USIM interface schematic on user's PC

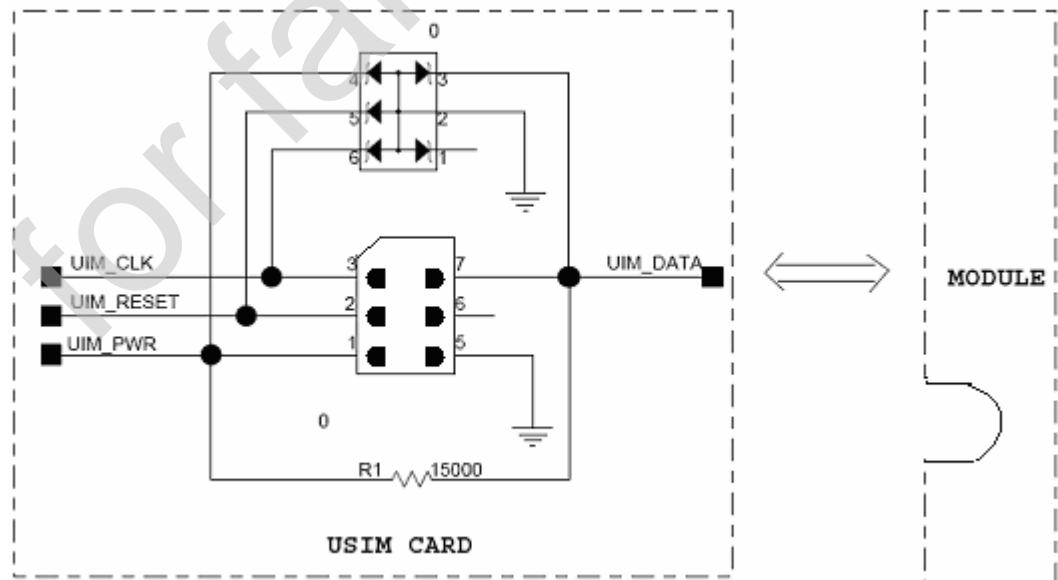

Design guide

The USIM signals are connected to the Mini PCI Express card connector (the card edge connector) and pass through an EMI filtering and ESD protection circuit on the module board before entering the EM770 processor. There is also an EMI filtering and ESD protection circuit between SIM card interface and Mini PCI interface on the user's board.

1. Power supply

The SIM interface is powered by an LDO regulator. The default value of this regulator is 2.85 V. The power of the regulator is programmable in the range of 1.5 V to 3.05 V and is expected to be set to 3.0 V or 1.8 V.

2. Modem signals

After a power-on or reset, the USIM signals are activated to detect if a SIM card is present and to initialize it if it exists. Once a card has been detected and initialized, the interface is always on. However, the clock signal is only activated when data is actually being transferred. The USIM signals from the MSM are connected to the level translators and then to the Mini Card host connector.

These levels exceed those required in ISO/IEC 7816-3.

3. SIM signals

The following data is taken from ETSI standard Specification of the 3 Volt Subscriber Identity Module - Mobile Equipment (SIM-ME) interface (GSM 11.12 version 4.3.1).

Table 3-7 SIM RST requirements

RST	Minimum	Maximum
V _{IL}	0	0.2V _{cc}
V _{IH}	0.7V _{cc}	V _{cc}

Table 3-8 SIM CLK requirements

CLK	Minimum	Maximum
V _{IL}	0	0.2V _{cc}
V _{IH}	0.7V _{cc}	V _{cc}

Table 3-9 SIM IO requirements

IO	Minimum	Maximum
V _{IL}	0	0.4
V _{IH}	0.7V _{cc}	V _{cc}
V _{OL}	-0.3	0.2V _{cc}

IO	Minimum	Maximum
V _{OH}	0.7V _{cc}	V _{cc} +0.3

The IO signal is bidirectional and is pulled up to VCC by a 20 kΩ resistor, as the standard recommends.

Note:

This pull-up resistor should be placed near to the SIM connector and it should be connected to the UIM PWR.

The V_{OL}max of 0.45 V for the outputs is specified at an output current of 3 mA whereas the V_{IL}max of 0.4 V for the SIM IO input is specified at an input current of 1 mA. With the smaller current drive, the output voltage would be driven lower than the stated maximum value.

4. ESD protection

Since the SIM is a CMOS device, ESD protection devices should be placed near to the SIM connector to provide protection. In addition, all the SIM interface signals should be bypassed with a 33 pF capacitor.

5. Clock frequency

The SIM must support clock frequencies between 1 MHz and 4 MHz. (The Mini Card can be programmed to generate a clock of 1.625 MHz, 2.6 MHz, or 3.25 MHz).

6. Routing recommendations

The SIM interface signals consist of four signals that are Vcc, RST, CLK, and IO (Vpp is also connected but not used in many applications). Due to the relatively low clock frequencies involved, the concern is not the degradation of the SIM signals themselves. The main concern is routing of the SIM interface signals through areas considered to be of high risk for RF noise coupling (crosstalk and RF contamination) which can desensitize the radio circuitry. The general guidelines that should be followed are listed as follows:

- I It is recommended that these signals should be routed over a contiguous ground plane.
- I SIM interface signals should not be routed near high transient signals (power supply chokes and DC/DC switching FETs).
- I Avoid routing of these signals near output connectors.
- I Keep SIM interface signals isolated from other signals. 2x width spacing (1.5x min) between SIM interface signals and all other signal routing is recommended.

3.2.5 W_DISABLE# Signal

The W_DISABLE# signal is provided to allow users to disable wireless communications add-in cards. When the W_DISABLE# signal is asserted, all radios should be disabled. When the W_DISABLE# signal is not asserted, the radio may transmit if not disabled by other means such as software.

The W_DISABLE# signal is an active low signal with internal 100 kΩ pull-up resistor that shall disable radio operation when being asserted (driven low) by the system.

Due to the potential of a software disable state, the combination of the software state and W_DISABLE# assertion state must be determined before the normal operation is

resumed. Table 3-11 lists this requirement on the function of W_DISABLE# and the software control setting. For example, the radio RF operation remains disabled unless both the hardware and software are set to enable the RF features of the card.

Table 3-10 W_DISABLE_N signal

Pins	Name	Description	Direction to Module
20	W_DISABLE_N	Close wireless communications	Input

Table 3-11 Radio operational states

W_DISABLE#	SW Control Setting*	Radio Operation
High	Enabled	Enabled
High	Disabled	Disabled
Low	Enabled	Enabled
Low	Disabled	Disabled

* This control setting is implementation specific; this column represents the collective intention of the host software to manage radio operation.

If PC uses a hardware switch or EC(Embedded Controller) control W_DISABLE#, 3.3V VCC Main Voltage and W_DISABLE# must meet Figure 3-2 power sequences.

Figure 3-2 power sequences timing diagram

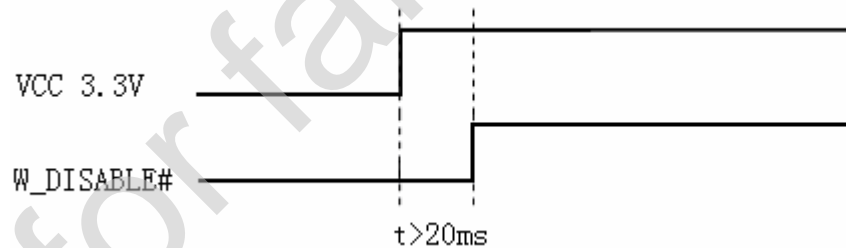

Note:

We strongly recommend controlling this pin via hot-keys or a hardware switch. There are three points as below:

1. If we don't turn off radio manually, radio will be on when module is powered on.
2. End users need turn off radio at some situation like on an airplane.
3. According to Mini-PCIE specification, we must turn off radio through hardware or software. Nearly all PC companies obey this specification.

3.2.6 LED_WWAN# Signal

The LED_WWAN signal of the EM770 can tolerate up to the voltage of 5 V and absorb the current up to 150 mA. According to the given circuit, in order to reduce the current of the LED, a resistance of 1 kΩ must be placed in series with the LED.

Table 3-12 LED_WWAN signal

Pins	Name	Description	Additional Description	Direction to Module
42	LED_WWAN	Active-low LED signal for indicating the status of the module.	L: Light on H: Light off	Output

This signal is used to display the state of WWAN. The reference circuit diagram is shown in the following figure.

Figure 3-3 LED_WWAN# signal reference circuit diagram

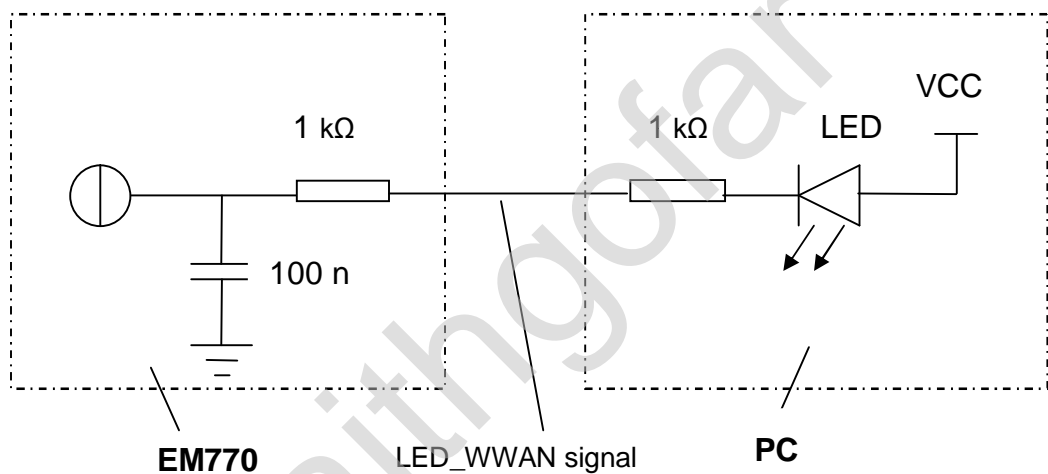

Note:

The wink mode of the LED can be customized by the demand of the client.

3.2.7 PERST# Signal

The PERST# signal has an internal pull-up. The active low input is used to hard reset the module.

The PERST# signal is de-asserted by the host to indicate that system power sources are within the specified voltage tolerance and are stable. PERST# can be asserted by the host when power is switched off and also can be used by the system to force a hardware reset on the card. However, a hardware reset is not required during normal operation and may only be used in case of module malfunction.

A hard reset of the module will result in a surprise removal of the module on the USB controller and cause the operating system to unload the device drivers. This will lead to a delay before the operating system discovers the device again. To avoid this delay, the PERST# pin should not be used in normal operation or in standby mode.

Table 3-13 PERST# signal

Pins	Name	Description	Additional Description	Direction to Module
22	PERST#	Force a hardware reset on the card.	H: normal or standby. L: Reset the EM770.	Input

3.2.8 NC Pins

The NC pins are not internally connected in the EM770.

3.3 Power Supply and Consumption

The EM770 is supplied by 3.3 V power source, which must satisfy all requirements of PCI Express Mini CEM specifications, such as voltage tolerance and peak and normal current. The detailed requirements are listed in Table 3-14.

Table 3-14 Power requirements

Power	Voltage Tolerance	Peak (Maximum)	Normal (Maximum)
3.3 V	±9%	2750 mA	1100 mA

Note:

- 1 In burst transmit mode of GSM/GPRS/EDGE, the peak current of the module will exceed 2 A, which will pull down the power voltage transitorily and perhaps result in the reset of the module or host. In order to avoid this case, you can add a large bulk capacitor beside the module on the host side.
- 1 To minimize the RF radiation through the PCI-E interface, you can add a 33 pF ceramic capacitor to ground on every pin of the PCI-E on the host side except USB D+/D-.

The power consumptions of the EM770 in different scenarios are respectively listed in Table 3-15.

Table 3-15 DC power consumption (HSPA/WCDMA/ GSM/GPRS/EDGE)

WCDMA/HSDPA data DC power consumption				
Description	Band	Test Value	Units	Power(dBm)
WCDMA	Band I(IMT2100)	291.3	mA	10dBm Tx Power
		661.3	mA	24dBm Tx Power
	Band II(PCS 1900)	312.6	mA	10dBm Tx Power
		723.5	mA	24dBm Tx Power
	Band V(850M)	299.8	mA	10dBm Tx Power
		645.2	mA	24dBm Tx Power



HSDPA	Band I(IMT2100)	337.2	mA	10dBm Tx Power
		707.3	mA	24dBm Tx Power
	Band II(PCS 1900)	358.5	mA	10dBm Tx Power
		769.4	mA	24dBm Tx Power
	Band V(850M)	345.7	mA	10dBm Tx Power
		691.2	mA	24dBm Tx Power
HSUPA	Band I(IMT2100)	347	mA	10dBm Tx Power
		717	mA	24dBm Tx Power
	Band II(PCS 1900)	366.3	mA	10dBm Tx Power
		777.2	mA	24dBm Tx Power
	Band V(850M)	353.5	mA	10dBm Tx Power
		698.9	mA	24dBm Tx Power

GSM/GPRS/EDGE talk/data DC power consumption				
Description	Test Value	Units	PCL	
GPRS900	446.74	mA	5	1 Up/1 Down
	728.7	mA	5	4 Up/1 Down
	256.7	mA	13	1 Up/1 Down
	476.9	mA	13	4 Up/1 Down

Description	Test Value	Units	PCL	
GPRS850	497.42	mA	5	1 Up/1 Down
	794.78	mA	5	4 Up/1 Down
	258	mA	13	1 Up/1 Down
	484.5	mA	13	4 Up/1 Down

Description	Test Value	Units	PCL	
GPRS1900	282.29	mA	0	1 Up/1 Down
	441.52	mA	0	4 Up/1 Down
	197.3	mA	10	1 Up/1 Down
	283.4	mA	10	4 Up/1 Down



Description	Test Value	Units	PCL	
GPRS1800	285.63	mA	0	1 Up/1 Down
	440.53	mA	0	4 Up/1 Down
	187.7	mA	10	1 Up/1 Down
	282.5	mA	10	4 Up/1 Down

Description	Test Value	Units	PCL	
EGPRS850	324.83	mA	5	1 Up/1 Down
	501.94	mA	5	4 Up/1 Down
	261.3	mA	13	1 Up/1 Down
	385.2	mA	13	4 Up/1 Down

Description	Test Value	Units	PCL	
EGPRS900	305.6	mA	5	1 Up/1 Down
	470.21	mA	5	4 Up/1 Down
	253.9	mA	13	1 Up/1 Down
	368.4	mA	13	4 Up/1 Down

Description	Test Value	Units	PCL	
EGPRS1800	244.61	mA	0	1 Up/1 Down
	352.41	mA	0	4 Up/1 Down
	227.5	mA	10	1 Up/1 Down
	315.34	mA	10	4 Up/1 Down

Description	Test Value	Units	PCL	
EGPRS1900	244.28	mA	0	1 Up/1 Down
	352.32	mA	0	4 Up/1 Down
	229.2	mA	10	1 Up/1 Down
	319.6	mA	10	4 Up/1 Down

4 RF Specifications

4.1 Operating Frequencies

Table 4-1 RF bands

EM770		
Operating Band	Tx	Rx
UMTS2100 (Band I)	1920–1980 MHz	2110–2170 MHz
UMTS 1900 (Band II)	1850–1910 MHz	1930–1990 MHz
UMTS 850 (Band V)	824–849 MHz	869–894 MHz
GSM850	824–849 MHz	869–894 MHz
GSM900	880–915 MHz	925–960 MHz
GSM1800	1710–1785 MHz	1805–1880 MHz
GSM1900	1850–1910 MHz	1930–1990 MHz

4.2 Conducted Rx sensitivity and Tx power

Table 4-2 EM770 conducted Rx sensitivity

Item	3GPP Protocol Claim	Test Value	Unit
GSM850 (CS, 2.43%)	<-102	-109	dBm
GSM900 (CS, 2.43%)	<-102	-109	dBm
DCS (CS, 2.43%)	<-102	-109	dBm
PCS (CS, 2.43%)	<-102	-109	dBm
BAND I (0.1%)	<-106.7	-110	dBm
BAND II (0.1%)	<-104.7	-109.5	dBm

Item	3GPP Protocol Claim	Test Value	Unit
BAND V (0.1%)	<-104.7	-109.5	dBm

Table 4-3 EM770 conducted Tx power

Item	3GPP Protocol Claim	Test Value	Unit
GSM850 (CS)	>31	32.5	dBm
GSM850 (PS)	>25	26.5	dBm
GSM900 (CS)	>31	32.5	dBm
GSM900 (PS)	>25	26.7	dBm
DCS (CS)	>28	29.5	dBm
DCS (PS)	>24	25.4	dBm
PCS (CS)	>28	29.5	dBm
PCS (PS)	>24	25.2	dBm
BAND I	>21	22.5	dBm
BAND II	>21	22	dBm
BAND V	>21	22	dBm

% = Bit Error Rate or Block Error Rate

4.3 Antenna Design Requirements

4.3.1 Recommended Index of the Module Antennas

Table 4-4 Recommended index of the main antenna

Working frequency	824–960 MHz and 1710–2170 MHz
Port impedance	50 Ohm
Port standing wave	< 2.5
Peak gain	> 0 dBi
Antenna efficiency	> 60%
Polarization	Linear polarization
Pattern	Omnidirectional

Table 4-5 Recommended index of the auxiliary antenna

Working frequency	869–894 MHz, 1930–1990 MHz, and 2110–2170 MHz
Port impedance	50 Ohm
Port standing wave	< 2.5
Peak gain	> -3 dBi
Antenna efficiency	> 30%
Polarization	Linear polarization
Pattern	Omnidirectional

Table 4-6 Recommended index of the isolation between the main antenna and the auxiliary antenna

Antenna isolation	< -10 dBi
-------------------	-----------

The recommended isolation between the module antennas and other PC antennas is as follows:

Because the PC has other internal antennas such as the WLAN antenna, to ensure the proper operation of each communication system, requirements on antenna isolation between different communication systems should be considered. Table 4-7 lists the recommended index of the antenna isolation.

Table 4-7 Recommended index of the isolation between the module antennas and other PC antennas

Antenna isolation	< -20 dBi
-------------------	-----------

4.3.2 Design Recommendations

Recommendations for Designing the Module Antennas

The design recommendations are as follows:

1. It is recommended that the module antennas are designed at the upper edge, left edge or right edge of the PC screen. Designing the antenna at the upper edge is better.
2. When designing the main antenna and the auxiliary antenna, the requirement on the antenna isolation should be considered (the recommended value is listed in Table 4-6). Meanwhile, try to keep the distance between the main antenna and the auxiliary antenna as large as possible for optimizing the space diversity. For example, you can place the main antenna at the upper left corner of the PC screen and place the auxiliary antenna at the upper right corner of the PC screen.

3. You are recommended to design the antenna pattern as the horizontal polarized omnidirectional pattern that facilitates the reception of strong signals especially in outdoor environments.
4. Besides the module antennas, a PC has other internal antennas, such as the WLAN antenna. Therefore, when designing the module antennas, the requirement on the isolation between module antennas and other PC antennas should be considered (the recommended value is listed in Table 4-7). Keep proper distance between antennas if possible. To reduce the interference between antennas, it is not recommended that an antenna is designed closely next to another one.
5. Carefully design the metallic components (such as the external frame of the metallic shell) in and near the antenna area with considering the effects on the antenna performance (such as whether the frequency offset of the antenna occurs and whether the antenna pattern is deformed).

Recommendations for Handling the Interference Sources

On a PC, there are various interference sources, such as the LCD, CPU, audio circuits, and power supply. All the interference sources emit interference signals that affect the normal operation of the module. For example, the module sensitivity can be decreased due to interference signals. Therefore, during the design, you need to consider how to lessen the effects of interference sources on the module. You can take the following measures: Use an LCD with optimized performance; shield the LCD interference signals; shield the signal cable of the PC; or design filter circuits.

4.4 Offline Mode

The offline mode can be enabled by the following methods:

- 1 Through hardware: The W_DISABLE pin can be used to control the RF circuit. When the pin is driven to the high level, the RF circuit works; when the pin is driven to the low level, the RF circuit does not work.
- 1 Through software: The AT command of AT^RFSWITCH can be used to control and query the status of the RF circuit.

For the offline mode, the following customizations can be realized on the firmware:

1. The RF circuit works each time the module is powered on.
2. The RF circuit does not work each time the module is powered on.
3. When the module is powered on for the first time, the RF circuit works, and then the module can remember the users' operations.
4. When the module is powered on for the first time, the RF circuit does not work, and then the module can remember the users' operations.

All the preceding customized states are set before the module is delivered and cannot be changed by the end users.

5 Software and Tools

Huawei can provide the firmware, PC driver, dashboard, and software. The firmware runs on the module; the PC driver and dashboard run on the PC and communicate with the firmware to realize all module functions. Huawei can also provide the software for upgrading the firmware and debugging the problems.

5.1 Firmware

The firmware is software on the module. It accepts commands and data from the host through USB. The host can send AT commands to enable the firmware to connect, disconnect, or query.

5.1.1 Version Descriptions

In the version number, the front digits is the firmware version that can differ which version is newer. The upper bits (except the last two bits) has boarder meaning in the version name. If the customer has special order to our common version, the order will be implemented in special version. The version is named by last two bits, but the front bits are still the common version.

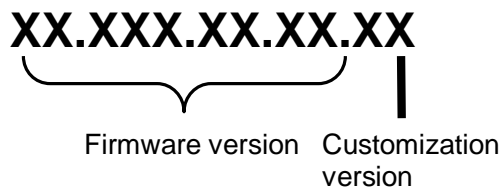

5.2 Drivers

A driver is a program running on the host system, which allows the host system to interact with the Huawei wireless module. The driver communicates with the firmware of the module by using the USB protocol.

The USB manufacturer ID for all Huawei USB devices is **0x12D1**.

The USB product ID for the EM770 device is **0x1001**. There are three USB interfaces in the USB product ID.

5.2.1 Windows Drivers

Huawei provides windows drivers to support Windows 2000/XP/Vista.

Huawei provides the following two ways to install the drivers:

- I The drivers are packed in the dashboard, and they will be installed during the dashboard installation.
- I The drivers are provided as an installer, which can be directly installed under Windows 2000/XP/Vista.

After the drivers are installed, when the EM770 is connected to the USB bus, it will be detected as a USB device and start enumerating. During this process, multiple drivers are loaded. These drivers expose a number of virtual COM ports.

In Windows OSs, you can check the enumerated devices and their configuration in the device manager. If you switch to **View by connection**, the device manager displays the main USB device and interfaces, as shown in Figure 5-1.

Figure 5-1 HUAWEI USB device and interfaces

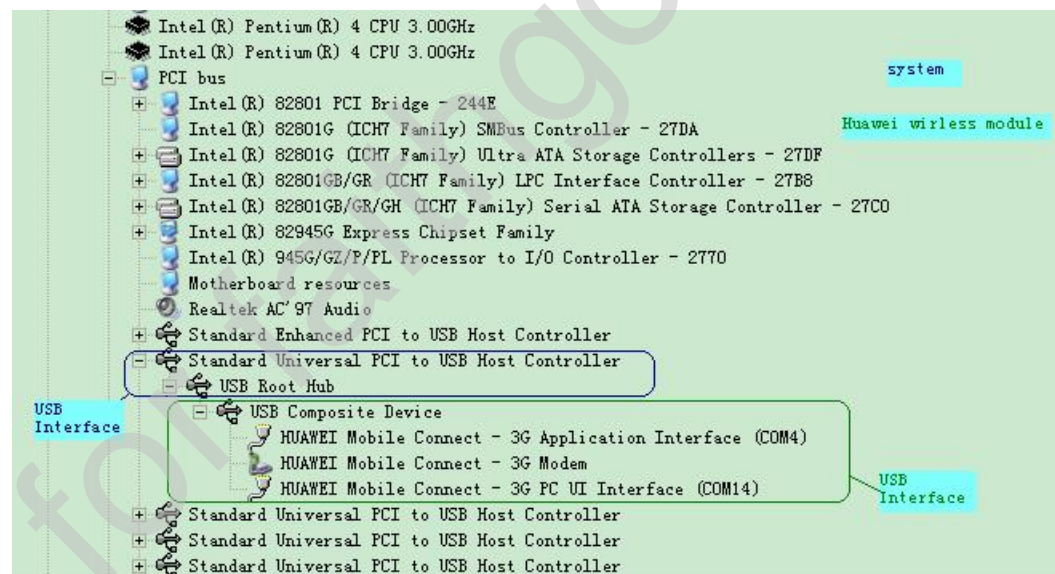

The following interfaces and port are displayed:

- I HUAWEI Mobile Connect – 3G Modem Port: used to set up a data connection
- I Huawei Mobile Connect – 3G Application Interface Port: used to write and read diagnostics data
- I HUAWEI Mobile Connect – 3G PC UI Interface: used to send AT commands and read their responses

5.2.2 Linux Drivers

The EM30V can be used in the Linux OS that the kernel version is 2.6.18 or later. If the kernel is a standard one, it means that the kernel is not customized and the driver

is already packed in the kernel; if the kernel is customized and the driver has been discarded, Huawei will provide the Linux driver for customers to merge the driver into the kernel again.

5.3 Dashboard

5.3.1 Windows Dashboard

Huawei can provide the dashboard to manage the connection and other functions under Windows 2000/XP/Vista.

Figure 5-2 shows the screenshot of Huawei common dashboard.

Figure 5-2 Screenshot of Huawei common dashboard

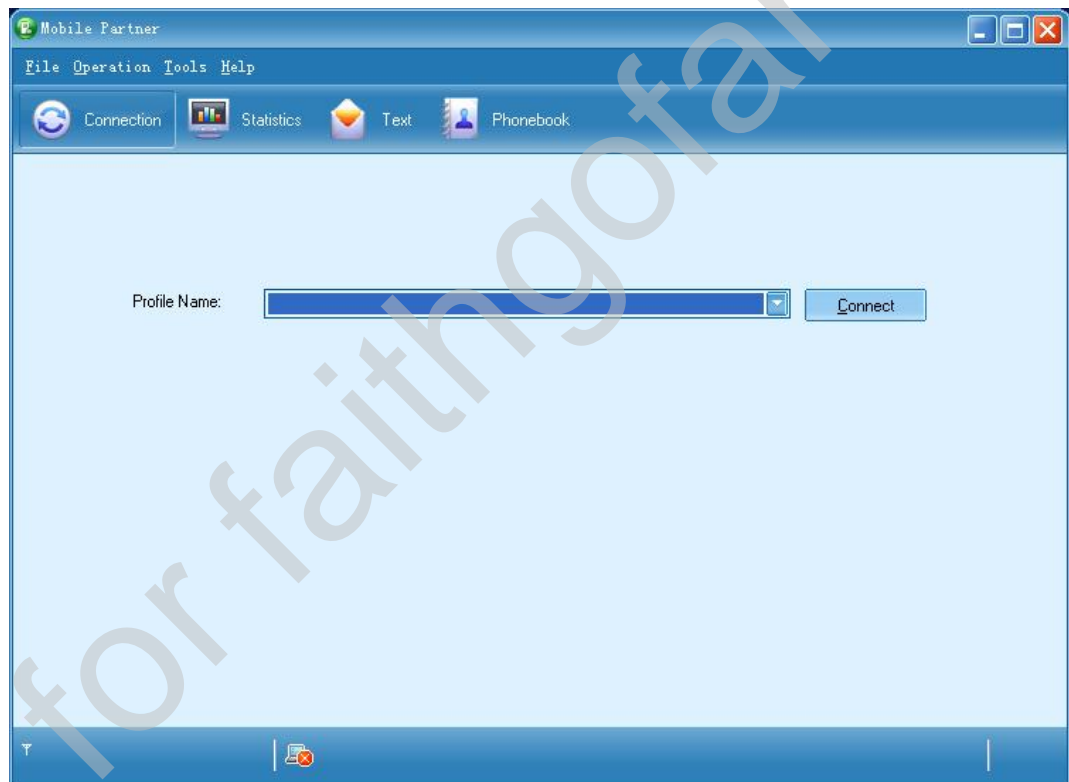

Table 5-1 lists the dashboard specifications.

Table 5-1 Dashboard specifications

Item	Description
SMS	Writing/Sending/Receiving
	Sending/Receiving extra-long messages
	Group sending

Item	Description
	Storage: The messages are saved in the hard disk of the PC.
	Sorting
	Importing: You can import messages from the SIM/USIM card to a PC.
	New message prompt (visual prompt/audio prompt)
Flow display and statistics (data services)	Current connection: <ul style="list-style-type: none"> ▫ Duration ▫ Send/Receive flow ▫ Send/Receive rate
	Traffic statistics: You can view the traffic information of the day, the month, or the year.
Phonebook	Capacity: It depends on the SIM/USIM card capacity or the hard disk space.
	Messages can be sent through the phonebook.
	Importing/Exporting: Import or export contacts between the SIM/USIM card and a PC or a file of supported formats.
Network connection setup	<ul style="list-style-type: none"> ▫ APN management: create, delete, edit, import, and export. ▫ Set up the network connection.
Network connection settings	<ul style="list-style-type: none"> ▫ Automatic network selection and registration ▫ Manual network selection and registration
Network status display	Signal status, operator name, system mode, and so on.
network connection types	Selection of network connection types, for example: <ul style="list-style-type: none"> ▫ 3G preferred ▫ GPRS preferred
PIN management	Activating or deactivating PIN, PIN lock, changing PIN, and unblocking PIN by using the PUK
System requirement	<ul style="list-style-type: none"> ▫ Windows 2000 SP4, Windows XP SP2, Windows Vista ▫ The hardware system on the PC should meet or exceed the recommended system requirements for the installed version of OS. ▫ Display resolution: 800 × 600 or above

Item	Description
Notes: CPU = central processing unit PIN = personal identification number PUK = PIN unblocking key	

5.3.2 Linux Dashboard

The Linux dashboard can be developed separately according to the customization requirements of customers.

5.4 Tools

5.4.1 Firmware Update Tool

The Windows-based update tool provided by Huawei is used to update the firmware of the EM770.

The following figures (from Figure 5-3 to Figure 5-9) show the procedure for using the EM770 update tool.

Figure 5-3 EM770 update tool



Figure 5-4 Screenshot of the EM770 update tool–Searching the device

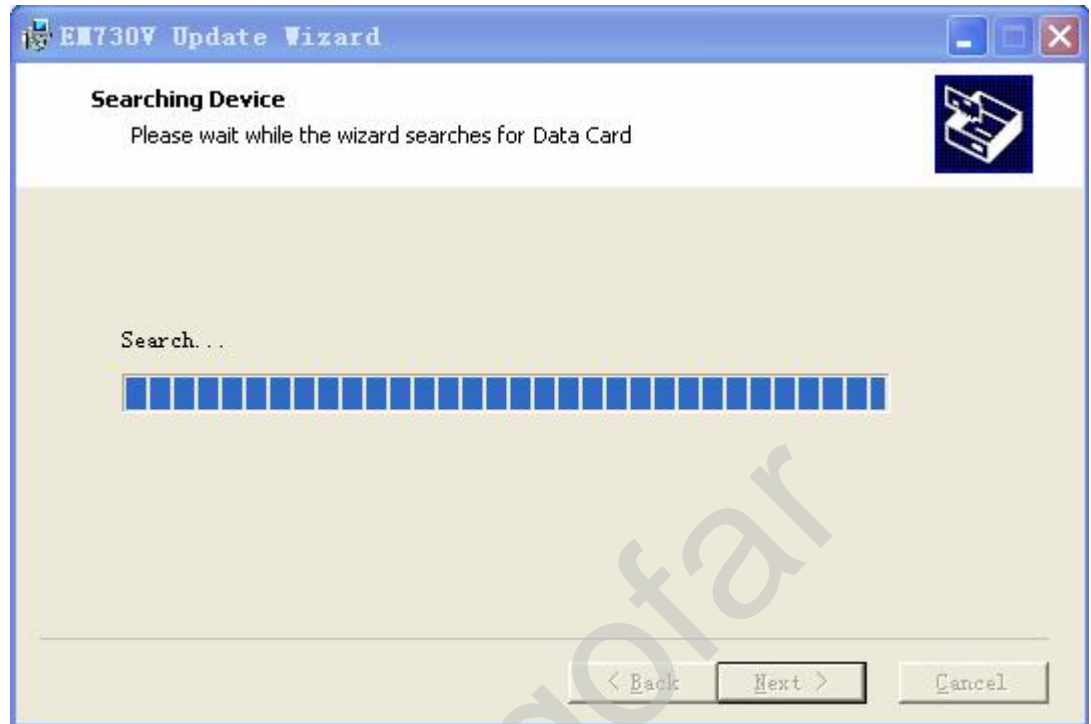

Figure 5-5 Screenshot of the EM770 update tool–Detected devices

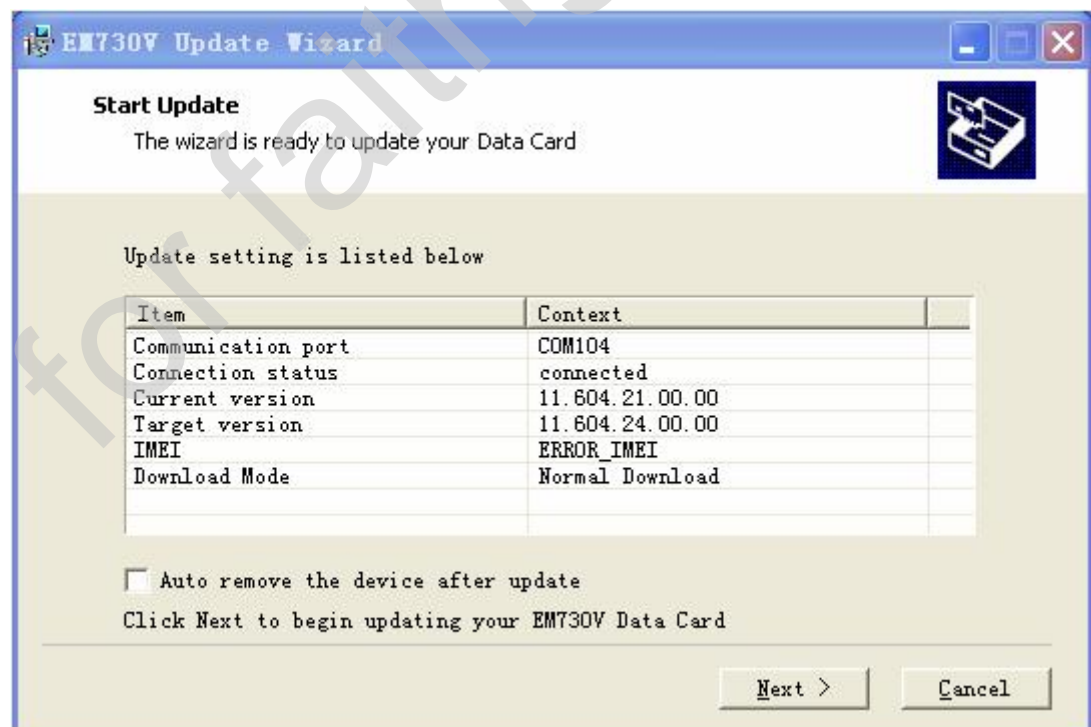

Figure 5-6 Screenshot of the EM770 update tool–Warning



Figure 5-7 Screenshot of the EM770 update tool–Downloading programs

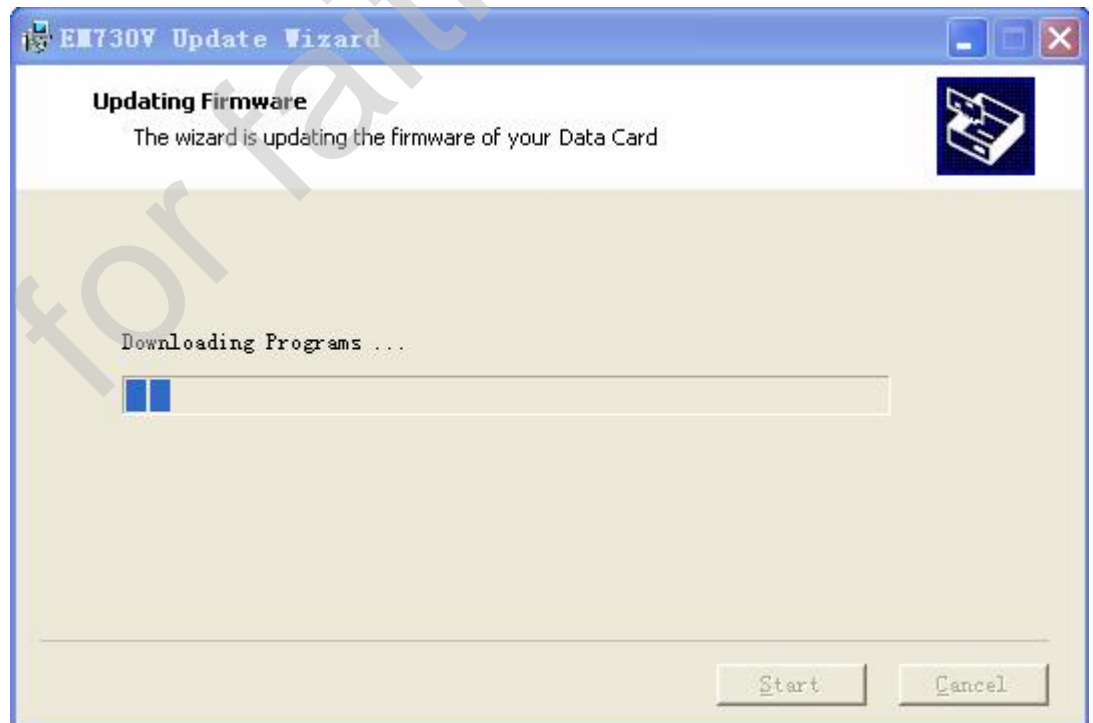

Figure 5-8 Screenshot of the EM770 update tool–Update succeeded



Figure 5-9 Screenshot of the EM770 update tool–To finish the update



5.4.2 Module Label Print Tool–MLT

The Windows-based MLT provided by Huawei can support the label print functions, check board information and check custom settings of the EM770.

5.4.2.1 MLT Installation

Figure 5-10 and Figure 5-11 show the procedure for installing the MLT.

You can choose installation location, and the default location is circled in red as shown in the following figure.

Figure 5-10 Starting to install the MLT

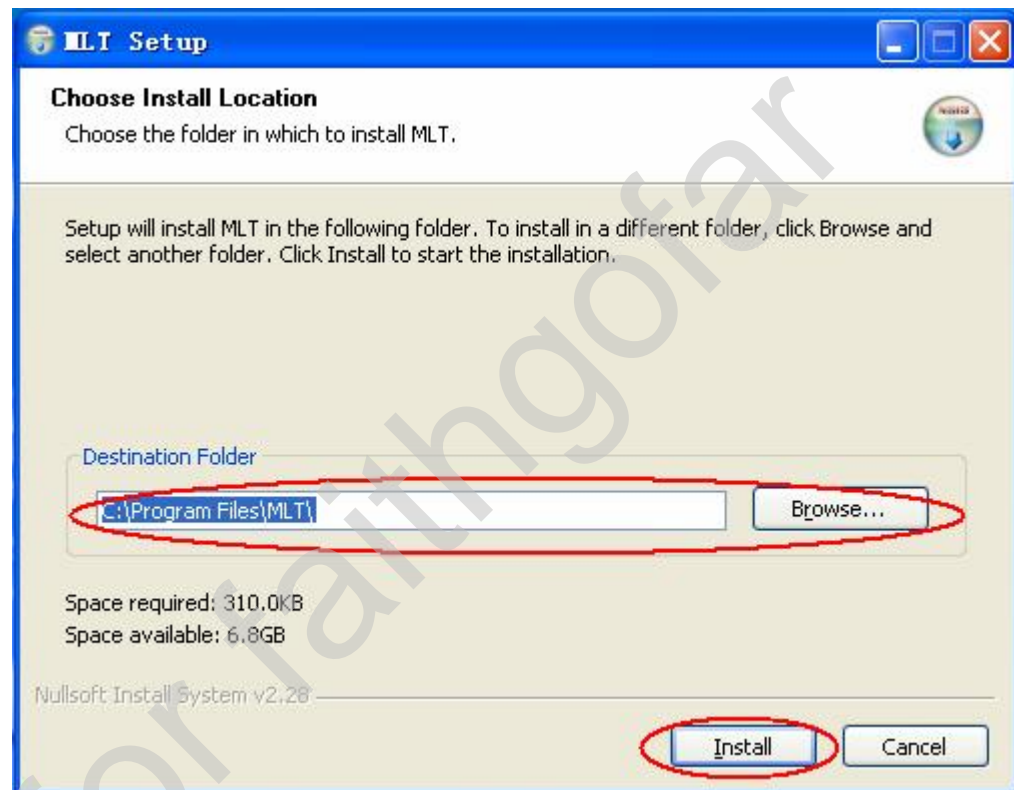
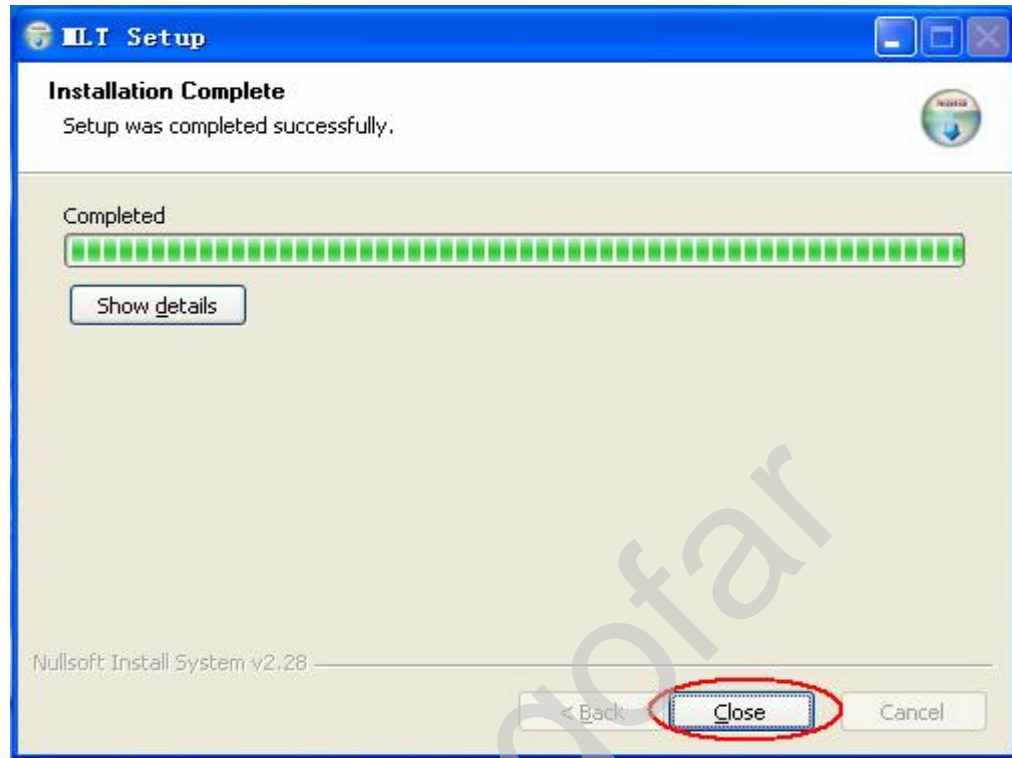

Figure 5-11 Completing the installation of the MLT



5.4.2.2 MLT Functions

The MLT provides the following three functions:

1. Check the information about custom settings.
2. Check the board information, such as the software version, hardware version, and dashboard version.
3. Print the IMEI and SN on the label.

The following figures (from Figure 5-12 to Figure 5-23) show the procedure for using the MLT.

Figure 5-12 Screenshot of the MLT main dialog box

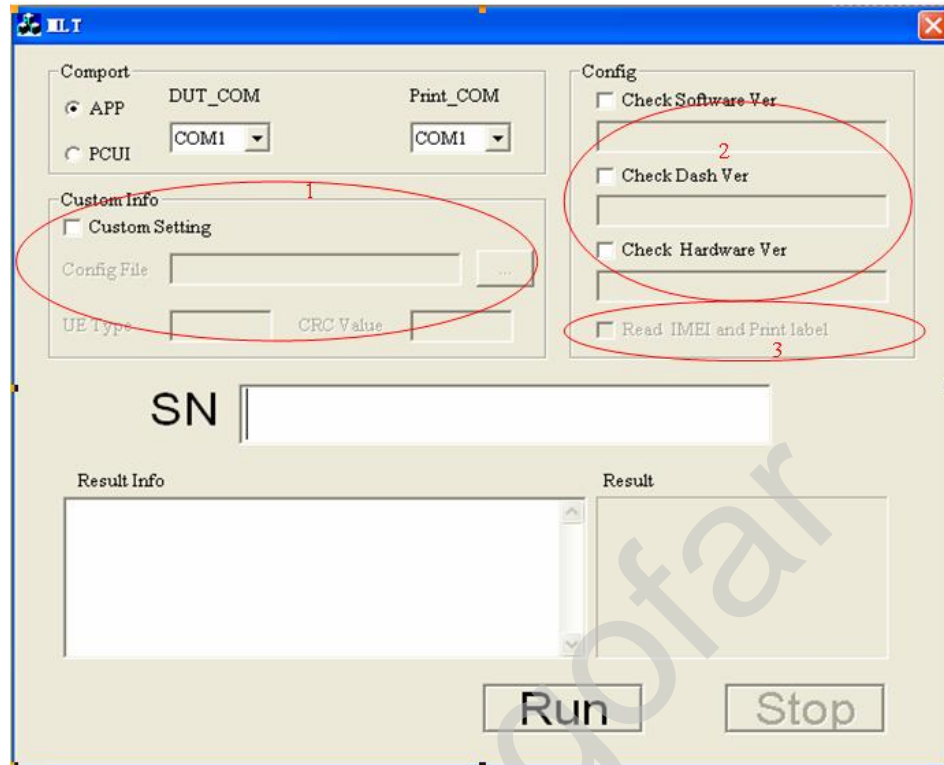

Figure 5-13 Selecting the corresponding port type and port number of the UE

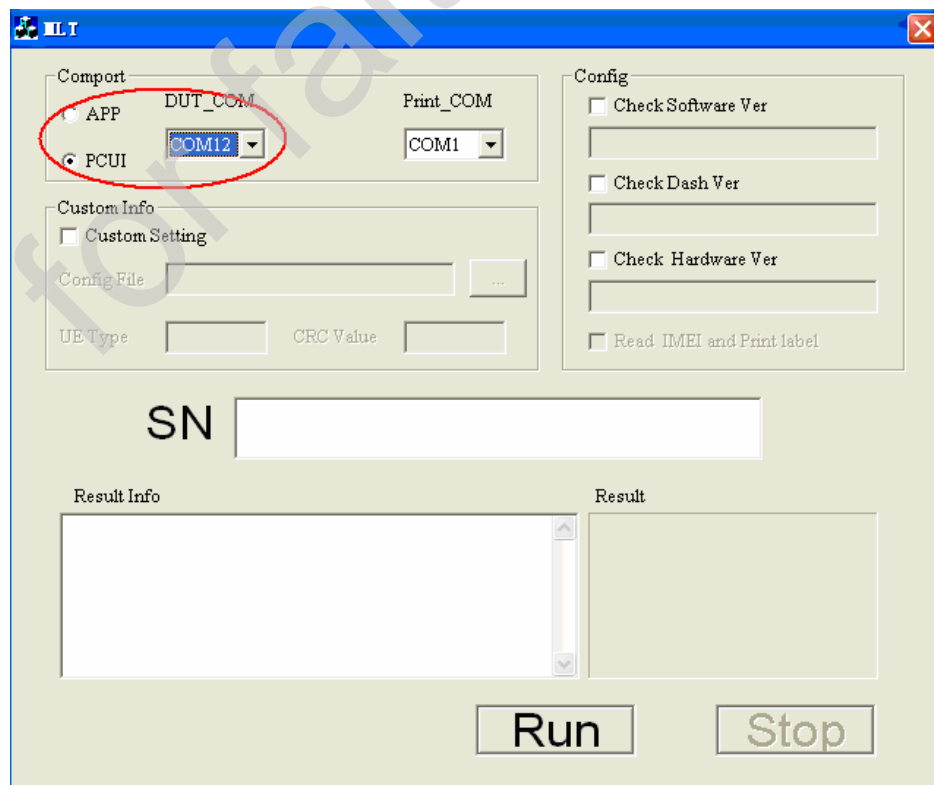

Figure 5-14 Selecting the printer port number

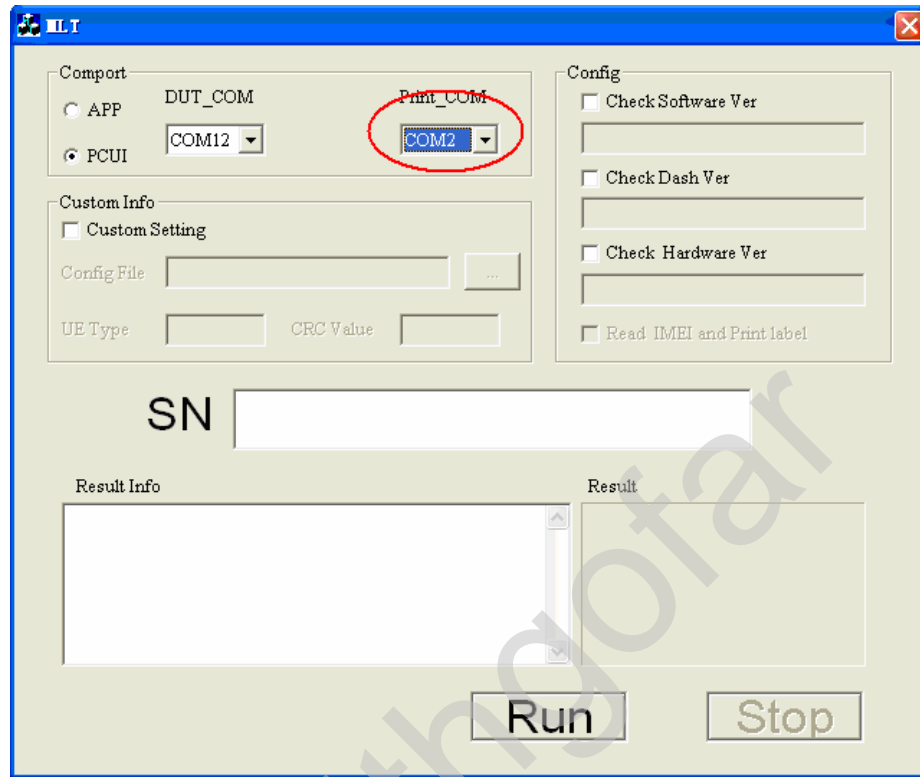

Figure 5-15 Selecting the check boxes in the Config area and enter the corresponding version information

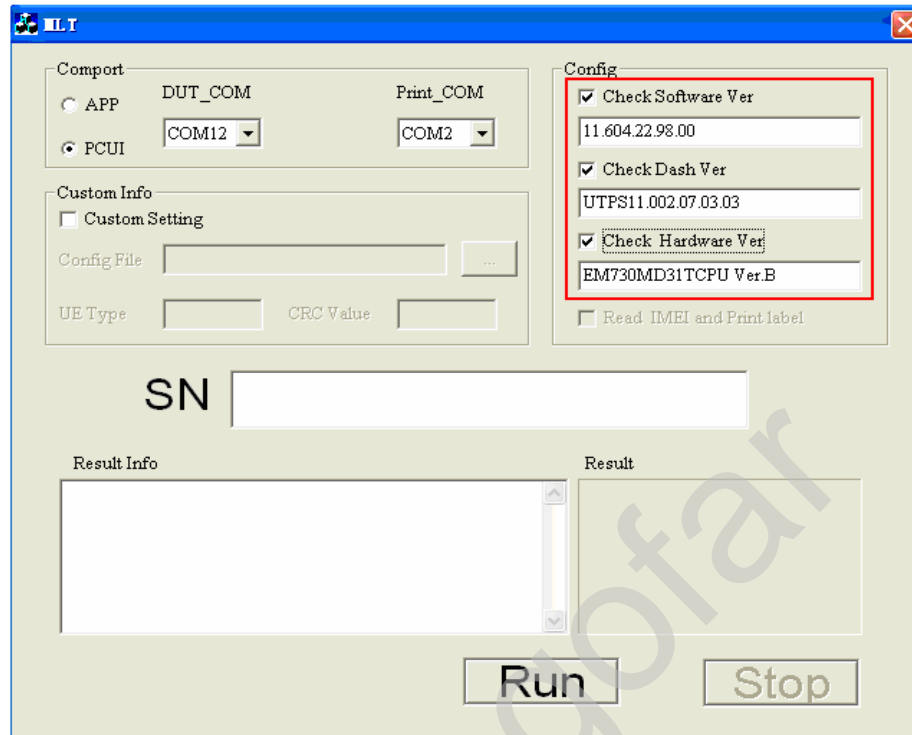

Figure 5-16 Selecting the Custom Setting check box in the Custom Info area

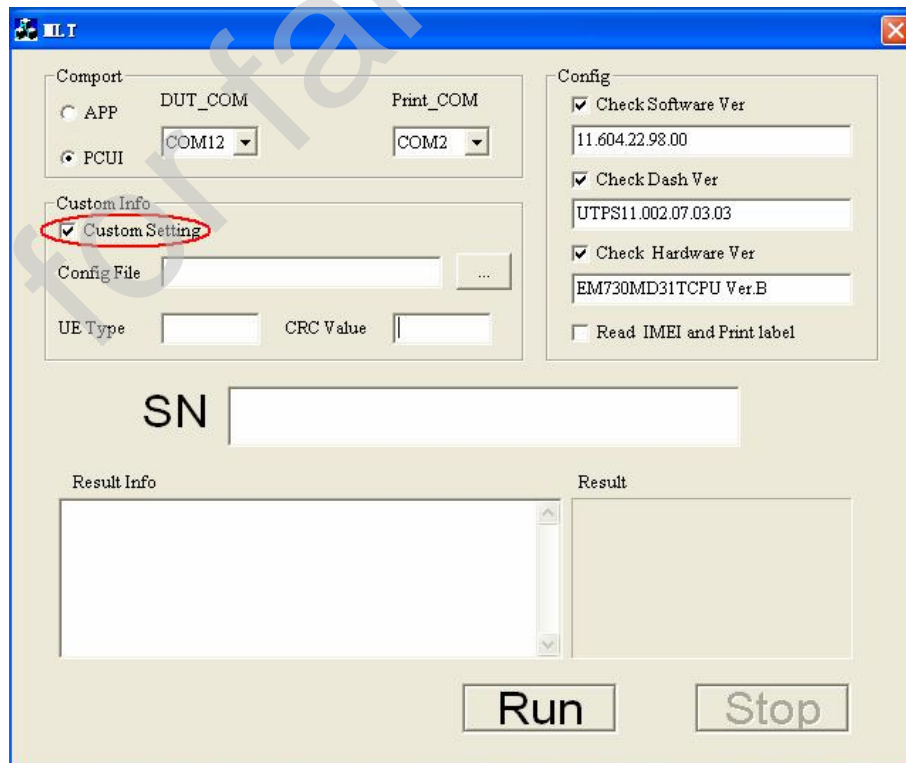

Figure 5-17 Selecting the corresponding configuration file

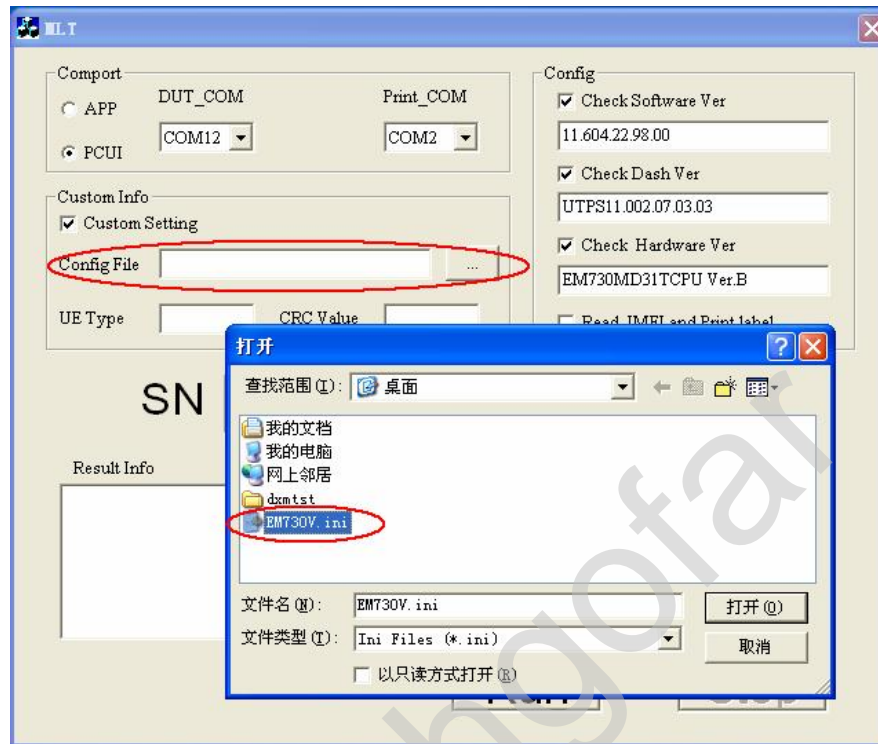

Figure 5-18 Entering the UE type and CRC value that are consistent with the configuration file

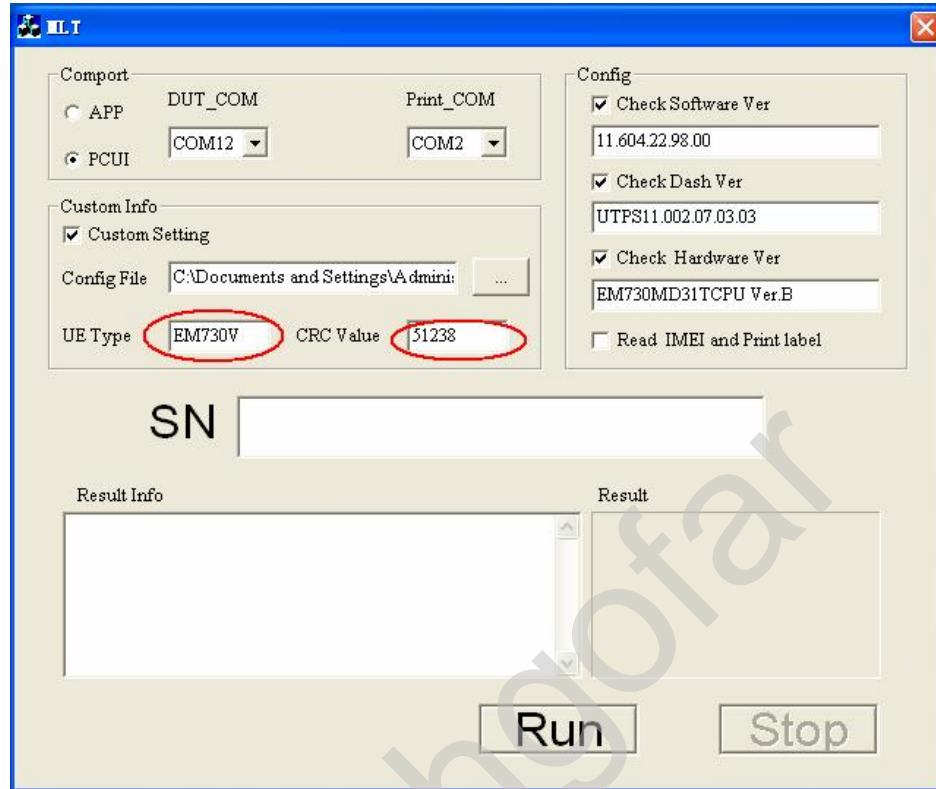
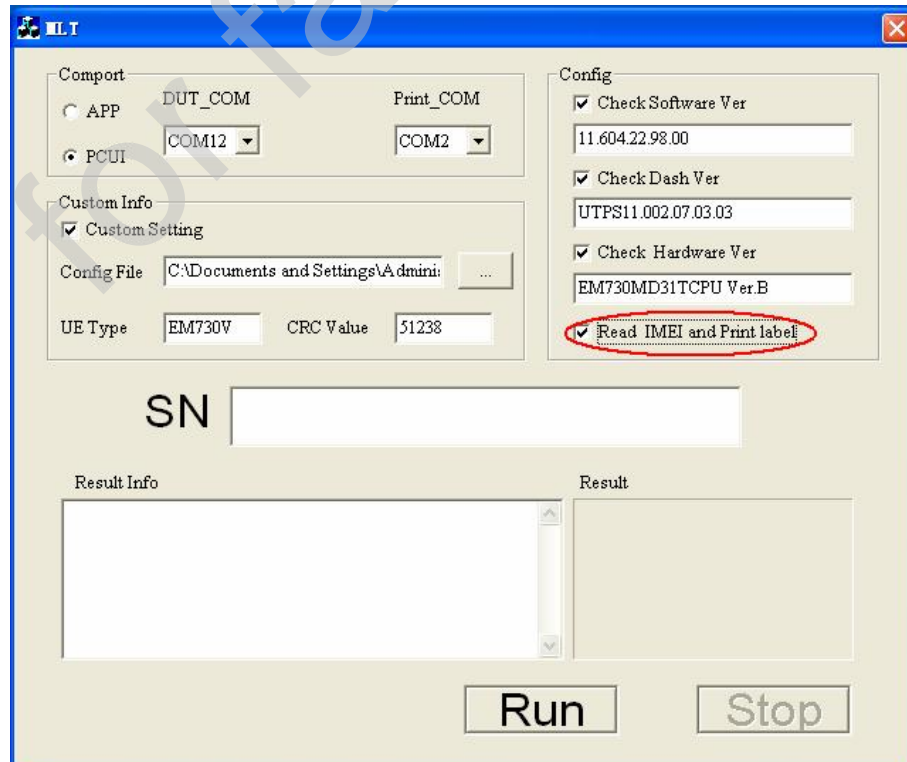

Figure 5-19 Selecting the function of printing the IMEI and SN on the label



As shown in Figure 5-19, if you want to print the IMEI and SN, you must select **Custom Setting** first; otherwise, **Read IMEI and Print label** is invalid. Then, connect a printer to print the label.

Figure 5-20 Scanning or entering the corresponding serial number (that consists of 16 digits)

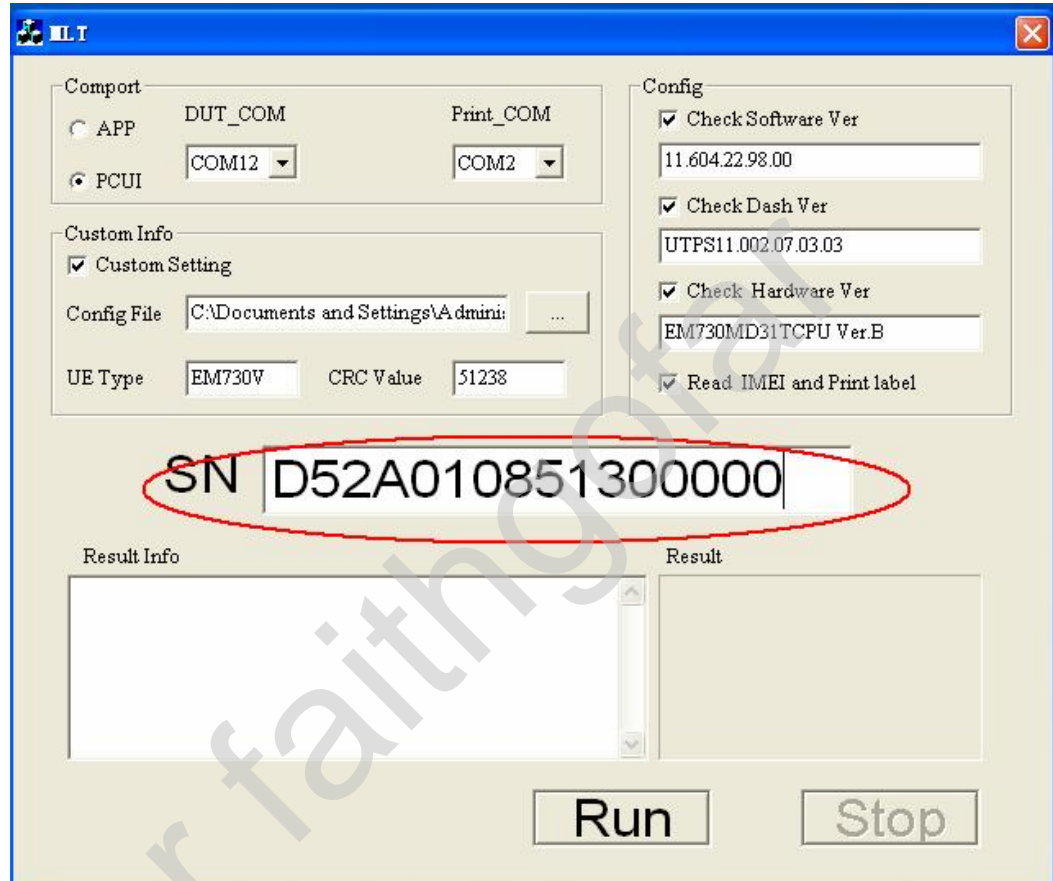

Figure 5-21 Clicking the Run button to start the MLT

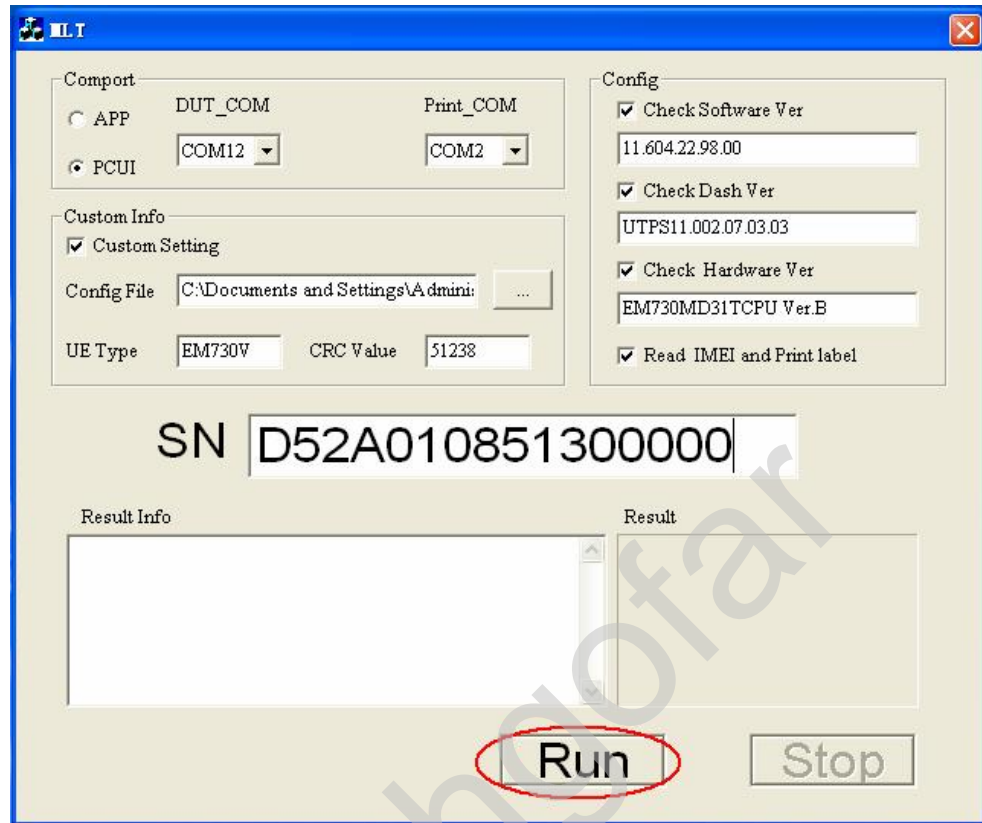

Figure 5-22 Displaying the test result PASS or FAIL

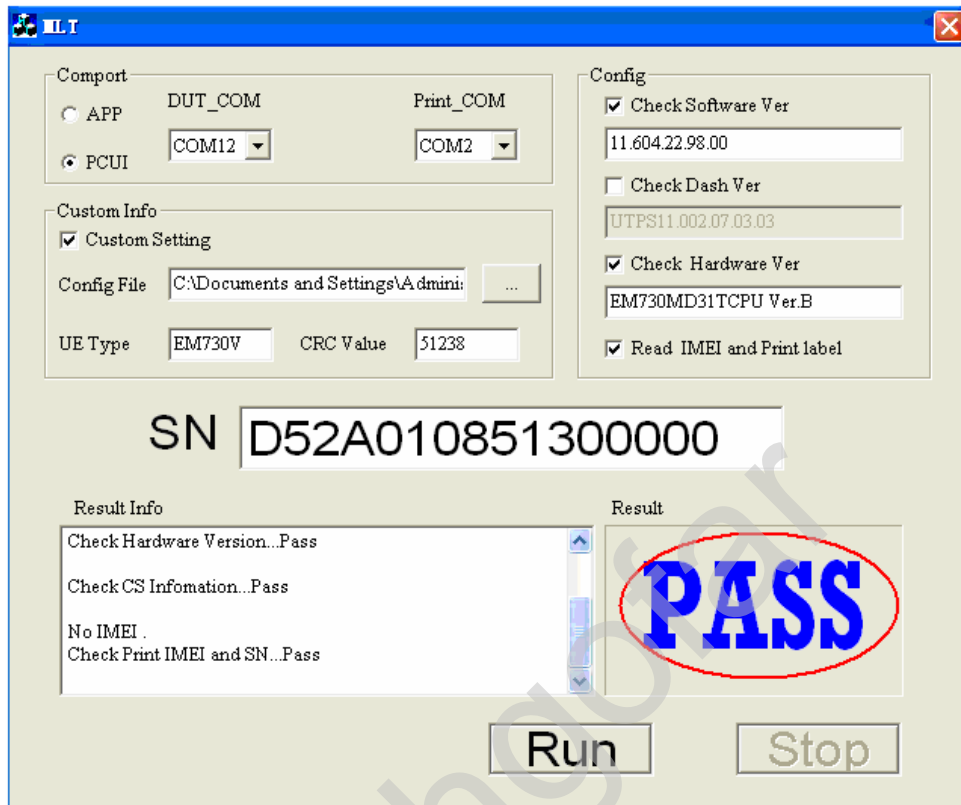
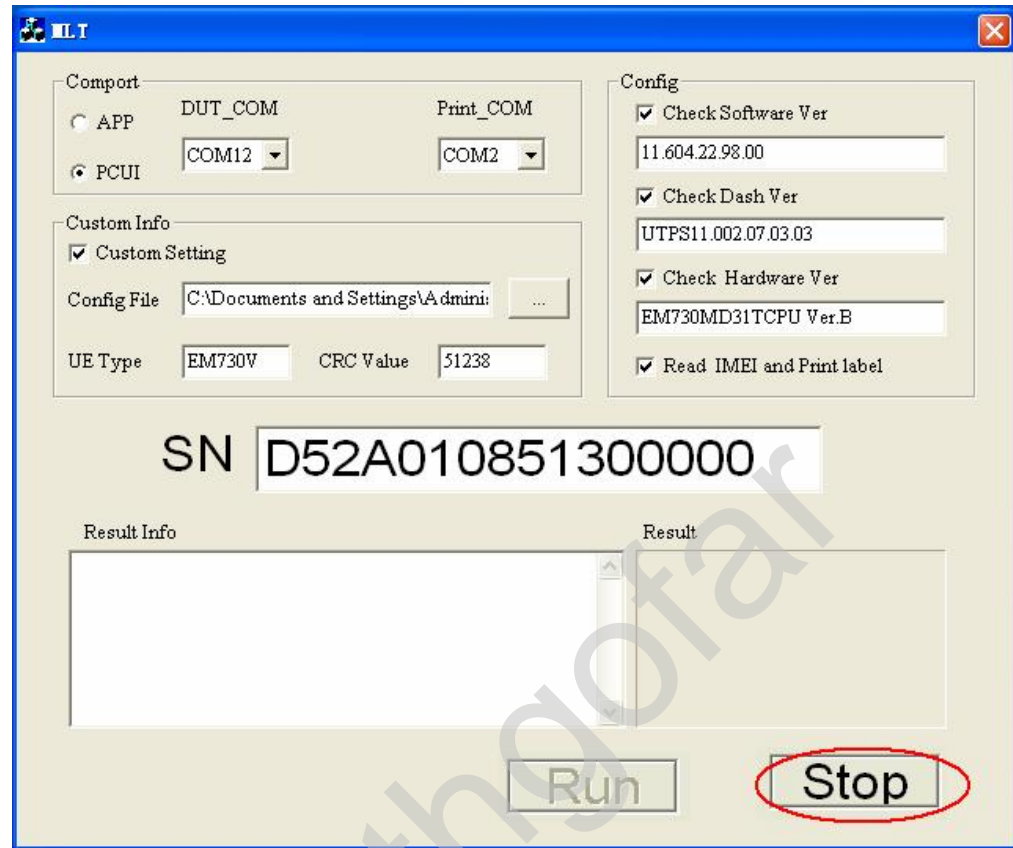

Figure 5-23 Clicking the Stop button to stop the MLT



5.4.3 Engineering Tools

Qualcomm has an extensive debugging and tracing toolset available for their chipsets. Huawei EM770 is compatible with these tools from Qualcomm, such as QXDM, QPST, and QCAT.

5.4.4 Debugging Board

I. Functions and Usage of the Debugging board

The debugging board developed by Huawei is an auxiliary board that is used to debug the EM770. When the debugging board is used, you can connect the module to a PC through a USB cable. When the module works normally, the debugging functions can be implemented. The debugging board provides multiple interfaces, such as the USB port, DC power jack, mini PCI-E connector, BTB connector, SIM card socket, RF connectors, PCM audio interface, and serial ports (including a 4-pin serial port and a serial port that all pins are led out). The test points of key signals are led out on the debugging board. In addition, the debugging board is designed with switches or pins of commonly used signals such as the reset signal and the enable signal, for converting the working state of the module.

The debugging board can be used to test the performance of the module. Both the wired connection test (connect the module to the CMU200) and the wireless

connection test (connect the module to the antennas) can be implemented. The signal points can also be tested when you maintain and repair the module.

II. Structure of the Debugging board

Figure 5-24 Structure of the debugging board

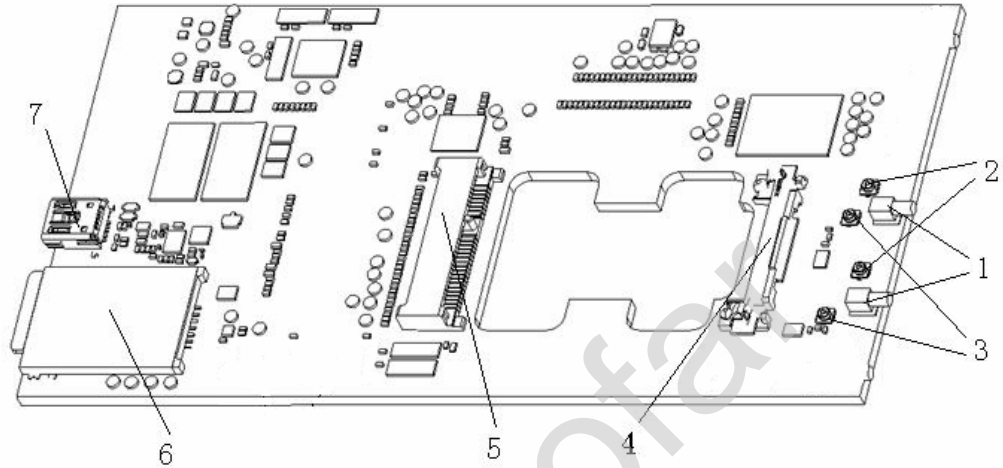

Note:

1. RF connector: RF switch, bend, female
2. RF connector: coaxial connector, straight, male
3. RF connector: RF switch, straight, female
4. Connector latch: It works with the mini PCI-E connector and is used for fixing the module.
5. Mini PCI-E connector: female, 52-pin, straight
6. SIM card socket: It is used to holding the inserted SIM card.
7. USB connector and mini USB B-type receptacle: Side-plugging USB connector

III. Method for Connecting the Debugging Board

1. Diagram of connecting the module to the CMU200

Figure 5-25 Diagram of connecting the module to the CMU200

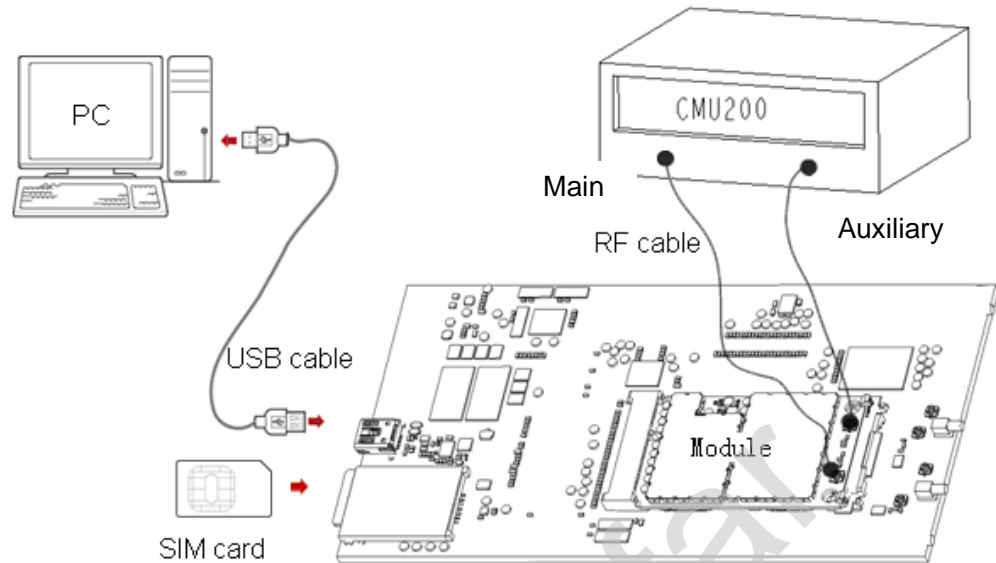

Figure 5-25 shows the connection method that can be used to test the wired connection comprehensively, software and key signal points.

2. Diagram of connecting the module and the antenna

Figure 5-26 Diagram of connecting the module and the antenna

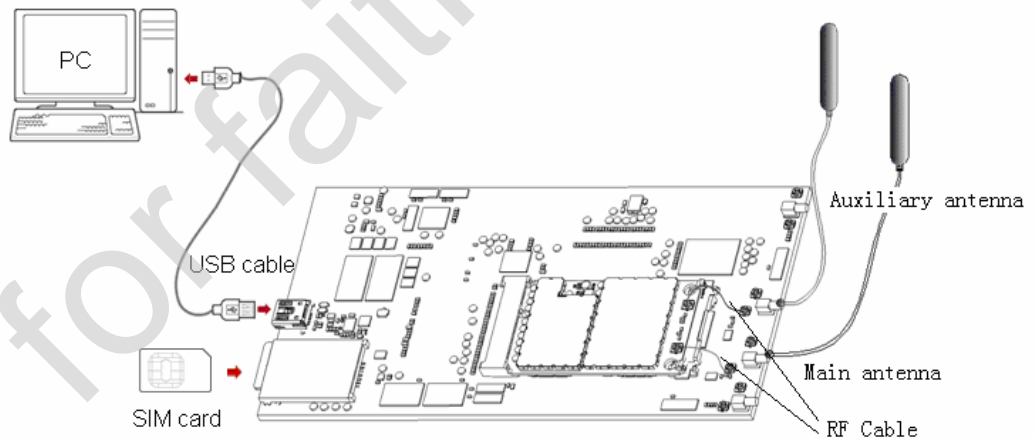

Figure 5-26 shows the wireless connection method that can be used to simulate the actual wireless environment for testing the software and key signal points.

IV. Installation of the Debugging board

- I Connect the devices and set up the test environment according to Figure 5-25 or Figure 5-26. Then properly connect one end of the module to the mini PCI-E connector and fix the other end of the module by well locking the connector latch. Insert the SIM card into the SIM card socket. Then connect the debugging board to the PC through a USB cable. You can connect the USB cable only when the module is properly connected to the mini PCI-E connector and fixed.

- I When performing the wired connection test, connect the CMU200 to the RF interface of the module by using the module-dedicated RF cable. (For the connection method, see Figure 5-25.) The compensation for the line loss of the CMU200 is about 0.7 dBm.
- I When performing the wireless connection test, connect the module to the debugging board by using the RF cable. Then connect the antennas to the RF interface of the module directly. (For the connection method, see Figure 5-26.)

V. Test Method

After the preceding operations, if the LED below the mini PCI-E connector, you can infer that the program is running. Then the following functions can be realized by using the debugging board.

1. Controlling the states and testing the performance in each state

The debugging board is designed with pins. You can control the module state through the pins. The silkscreen printing is used to label the pins on the debugging board.

You can manually control the power supply, dormant, waking up, and RF functions, and the reset state through the following pins:

- I J101: You can manually control the input enable signal (VEN) of the LTC3442 chip. When you connect the jumper header to the right of J101 (VEN is driven to the low level), the power supply is cut off; when you remove the jumper header, no impact is caused to the power output.
- I J202: You can manually control the signal (WAKEUP_N) that the PC uses to wake up the module. When you connect the jumper header to the left of J202 (WAKEUP_N is driven to the low level), the module works; when you connect the jumper header to the right of J202 (driven to high level), the module hibernates.
- I J203: You can manually control the signal (WAKE_NB_N) that the module uses to activate the PC. When you connect the jumper header to the left of J203 (WAKE_NB_N is driven to the low level), the PC can be activated and the main power supplies the power; when you connect the jumper header to the right of J203 (driven to the high level), no impact is caused to the PC.
- I J204: You can manually control the module reset signal (PERST_N).When you connect the jumper header to the right of J204 (PERST_N is driven to the low level), the module is reset; when you remove the jumper header, the module works normally.
- I J205: You can manually control the signal (W_DISABLE_N) for disabling the RF function of the module. When you connect the jumper header to the left of J205 (W_DISABLE_N is driven to the low level), the RF function of the module is disabled and the module enters the offline mode; when you connect the jumper header to the right of J205 (driven to the high level), the RF function of the module is enabled.

You can manually control the PCM voice function of the debugging board through the following pins:

- I J501: You can manually control the signal (MICMUTE) for muting the microphone used for the PCM voice function. When you connect the jumper header to the left of the J501 (MICMUTE is driven to the high level), the microphone is muted.

- I J501: You can manually control the signal (EARMUTE) for muting the earphone used for the PCM voice function. When you connect the jumper header to the left of the J502 (EARMUTE is driven to the high level), the earphone is muted.
- I J503: You can manually control the signal (COMP_SEL) for selecting the working mode of the PCM voice function. When you connect the jumper header to the left of J530 (COMP_SEL is grounded and driven to the low level), the 13-bit linear mode is selected; when you connect the jumper header to the right of J503, the 8-bit compressed mode is selected.
- I J504: You can manually control the reset signal (PCM_RESET) of the PCM voice function. When you connect the jumper header to the bottom of J204 (PCM_RESET is driven to the low level), the PCM function is reset; when you remove the jumper header, the PCM function works normally.

Though controlling the module states manually, you can test the performance and parameter in each state by using the CMU200 or other matching software.

2. Testing the key signals

On the debugging board, the test points of all signification signals are led out for testing. Figure 5-27 shows positions of the test points.

Figure 5-27 Test point position

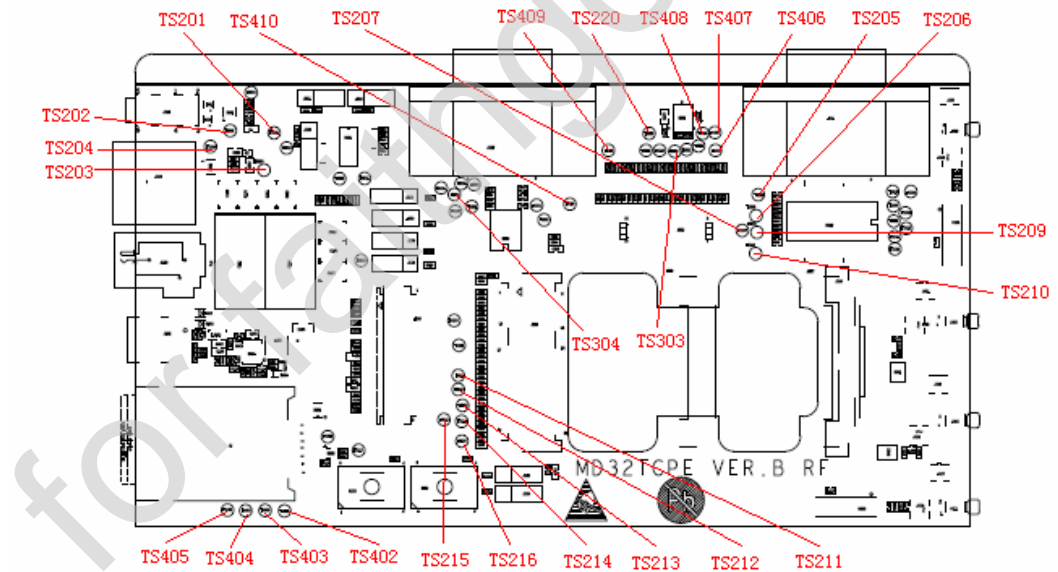

The test points shown in the previously figure are described as follows:

- TS408: WAKE_NB_N (signal that the module uses to activate the PC)
- TS406: WAKEUP_N (signal that the PC uses to wake up the module)
- TS407: W_DISABLE_N (signal for disabling the RF function of the module)
- TS409: PERST_N (module reset signal)
- TS201: MIC_P (input signal of microphone +)
- TS202: MIC_N (input signal of microphone -)

TS203: EAR_P (input signal of earphone +)
TS204: EAR_N (input signal of earphone -)
TS205: UART1_RX (Rx signal of the serial port 1)
TS206: UART1_TX (Tx signal of the serial port 1)
TS207: UART1_RI (RI signal of the serial port 1)
TS209: UART1_CTS (CTS signal of the serial port 1)
TS210: UART1_RFR (RFR signal of the serial port 1)
TS211: UART1_DTR (DTR signal of the serial port 1)
TS212: UART1_DCD (DCD signal of the serial port 1)
TS303: UART3_RX (Rx signal of the serial port 3)
TS304: UART3_TX (Tx signal of the serial port 3)
TS213: AUX_PCM_CLK (PCM clock signal)
TS214: AUX_PCM_DOUT (PCM digital output signal)
TS215: AUX_PCM_DIN (PCM digital input signal)
TS216: AUX_PCM_SYNC (PCM synchronization signal)
TS402: UIM_PWR (power voltage signal of the UIM card)
TS403: UIM_RESET (UIM card reset signal)
TS404: UIM_CLK (UIM card clock signal)
TS405: UIM_DATA (UIM card data signal)
TS220: LED_WWAN (control signal of displaying the module state)
TS410: GND

By using the test points on the debugging board, you can test the key signals, resistors, or test points on the module.

VI. Material List

Table 5-2 Material list

Item	Part Number	Quantity	Description
PC	-	1	It is provided by the customer.
CMU200	-	1	It is provided by the customer.
USIM or SIM card	-	1	It is provided by the customer.
Debugging board	03020NTP	1	



USB cable	02450626	1	It is a 17 cm USB cable used to connect the USB-A connector to Mini USB-B connector.
Antenna	27160038	1	
RF cable 1	02450717	2	It is a 5 cm cable used to connect the debugging board to the module.
RF connector	02450716	1	It is a female-type RF connector used to connect the RF cable to the module.
RF cable 2	02450709	1	It is used to connect the CMU200 to the module.

for faithgofai

6 Technical Reference

6.1 Layer 1 Specifications (Physical)

- | Examples of Channel Coding and Multiplexing TR 25.944
- | Physical Layer–General Description TS 25.201
- | Physical Channels and Mapping of Transport Channels onto Physical Channels (FDD) TS 25.211
- | Multiplexing and Channel Coding (FDD) TS 25.212
- | Spreading and Modulation (FDD) TS 25.213
- | Physical Layer–Procedures (FDD) TS 25.214
- | Physical Layer–Measurements (FDD) TS 25.215
- | 3GPP HSPA overall description 25.308
- | 3GPP UE radio access capabilities 25.306

6.2 Layer 2 Specifications (MAC/RLC)

- | MAC Protocol Specification TS 25.321
- | RLC Protocol Specification TS 25.322

6.3 Layer 3 Specifications (RRC)

- | UE Interlayer Procedures in Connected Mode TS 25.303
- | UE Procedures in Idle Mode TS 25.304
- | RRC Protocol Specification TS 25.331

6.4 Layer 3 NAS/Core Network (MM/CM)

- | Architectural Requirements for Release 1999 TS 23.121
- | NAS Functions Related to Mobile Station (MS) in Idle Mode TS 23.122
- | Mobile Radio Interface Signaling Layer 3–General Aspects TS 24.007

- | Mobile Radio Interface Layer 3 Specification–Core Network TS 24.008
- | PP SMS Support on Mobile Radio Interface TS24.011

6.5 GSM Protocol Specifications

- | Mobile Radio Interface Layer 3 Specification, Radio Resource Control Protocol TS 04.18
- | Mobile Station–Base Station System (MS–BSS) interface; Data Link (DL) Layer Specification TS 04.06
- | Digital Cellular Telecommunications System (Phase 2+); Multiplexing and Multiple Access on the Radio Path TS 05.02
- | Technical Specification Group GERAN; Channel coding TS 05.03
- | Digital Cellular Telecommunications System (Phase 2+); Radio Subsystem Link Control TS 05.08
- | Digital Cellular Telecommunications System (Phase 2+); Radio Subsystem Synchronization TS 05.10

6.6 GPRS Protocol Specifications

- | Overall Description of the GPRS Radio Interface; stage 2 TS 3.64
- | Mobile Radio Interface Layer 3 Specification TS 04.08
- | Mobile Radio Interface Layer 3 Specification: Radio Resource Control Protocol TS 04.18
- | General Packet Radio Service (GPRS): Mobile Station (MS)–Base Station System (BSS) interface; Radio Link Control/Medium Access Control (RLC/MAC) protocol TS 04.60
- | Mobile Station–Serving GPRS Support Node (MS–SGSN) Logical Link Control (LLC) Layer Specification TS 04.64
- | Mobile Station–Serving GPRS Support Node (MS–SGSN); Subnetwork Dependent Convergence Protocol (SNDCP) TS 04.65
- | Multiplexing and Multiple Access on the Radio Path TS 05.02
- | Channel Coding TS 05.03
- | Modulation TS 05.04
- | Radio Transmission and Reception TS 05.05
- | General Packet Radio Service (GPRS); Stage 1 TS 22.060
- | Mobile Execution Environment (MexE) TS 23.057
- | General Packet Radio Service (GPRS) Service description; stage 2 TS 23.060

6.7 General Specifications

- | UE Capability Requirements TR 21.904
- | UE Radio Access Capabilities TR 25.926
- | Vocabulary TR 25.990

- | Radio Interface Protocol Architecture TS 25.301
- | Services Provided by the Physical Layer TS 25.302
- | Synchronization in UTRAN Stage 2 TS 25.402

6.8 Performance/Test Specifications

- | UE Radio Transmission and Reception (FDD) TS 25.101
- | Common Test Environments for User Equipment (UE) TS 34.108
- | Special Conformance Testing Functions TS 34.109
- | Terminal Conformance Specification TS 34.121
- | User Equipment (UE) Conformance Specification; Part 1: Protocol Conformance TS 34.123-1
- | User Equipment (UE) Conformance Specification; Part 2: Protocol Conformance TS 34.123-2

6.9 SIM Specifications

- | SIM and IC Card Requirements TS 21.111
- | 3rd Gen. Partnership Proj Tech. Spec. Group Terminals; SIM App. Toolkit (USAT) TS 31.111

Acronyms and Abbreviations

3G	Third Generation
3GPP	3rd Generation Partnership Project
APN	Access Point Name
ARPU	Average Revenue Per User
BSS	Base Station Subsystem
CM	Connection Management
CPU	Central Processing Unit
CS domain	Circuit Switched domain
DTM	Digital Trunk Module
EDGE	Enhanced Data Rates for GSM Evolution
EGPRS	Enhanced GPRS
FDD	Frequency Division Duplex
GERAN	GSM/EDGE Radio Access Network
GPRS	General Packet Radio Service
GSM	Global System for Mobile Communications
HSPA	High Speed Downlink Packet Access
IC	Integrated Circuit
LED	Light Emitting Diode
MAC	Medium Access Control
MexE	Mobile Execution Environment
Mini PCI Express	Mini Peripheral Component Interconnect Express
MM	Mobility Management
Modem	Modulator Demodulator
MS	Mobile Station
MSC	Mobile Switching Center
NAS	Non-Access Stratum

OS	Operating System
PC/SC	Personal Computer/Smart Card
PIN	Personal Identification Number
PnP	Plug and Play
PP	Point-to-Point
PS domain	Packet Switched domain
PUK	PIN Unblocking Key
RF	Radio Frequency
RLC	Radio Link Control
RRC	Radio Resource Control
SGSN	Serving GPRS Support Node
SIM	Subscriber Identity Module
SMS	Short Messaging Service
SNDCP	Subnetwork Dependent Convergence Protocol
TR	Technical Report
TS	Technical Specification
UE	User Equipment
UMTS	Universal Mobile Telecommunications System
USAT	USIM Application Toolkit
USB	Universal Serial Bus
USIM	UMTS Subscriber Identity Module
UTRAN	UMTS Terrestrial Radio Access Network
WCDMA	Wideband Code Division Multiple Access
WWAN	Wireless Wide Area Network
PCIE CEM specification	PCI Express Mini Card Electromechanical Specification

Safety Information

Read the safety information carefully to ensure the correct and safe use of your wireless device. Applicable safety information must be observed.



Interference

Power off your wireless device if using the device is prohibited. Do not use the wireless device when it causes danger or interference with electric devices.



Medical Device

- | Power off your wireless device and follow the rules and regulations set forth by the hospitals and health care facilities.
- | Some wireless devices may affect the performance of the hearing aids. For any such problems, consult your service provider.
- | Pacemaker manufacturers recommend that a minimum distance of 15 cm be maintained between the wireless device and a pacemaker to prevent potential interference with the pacemaker. If you are using an electronic medical device, consult the doctor or device manufacturer to confirm whether the radio wave affects the operation of this device.



Area with Inflammables and Explosives

To prevent explosions and fires in areas that are stored with inflammable and explosive devices, power off your wireless device and observe the rules. Areas stored with inflammables and explosives include but are not limited to the following:

- | Gas station
- | Fuel depot (such as the bunk below the deck of a ship)
- | Container/Vehicle for storing or transporting fuels or chemical products
- | Area where the air contains chemical substances and particles (such as granule, dust, or metal powder)
- | Area indicated with the "Explosives" sign
- | Area indicated with the "Power off bi-direction wireless equipment" sign
- | Area where you are generally suggested to stop the engine of a vehicle



Traffic Security

- | Observe local laws and regulations while using the wireless device. To prevent accidents, do not use your wireless device while driving.
- | RF signals may affect electronic systems of motor vehicles. For more information, consult the vehicle manufacturer.
- | In a motor vehicle, do not place the wireless device over the air bag or in the air bag deployment area. Otherwise, the wireless device may hurt you owing to the strong force when the air bag inflates.



Airline Security

Observe the rules and regulations of airline companies. When boarding or approaching a plane, power off your wireless device. Otherwise, the radio signal of the wireless device may interfere with the plane control signals.



Safety of Children

Do not allow children to use the wireless device without guidance. Small and sharp components of the wireless device may cause danger to children or cause suffocation if children swallow the components.

Environment Protection

Observe the local regulations regarding the disposal of your packaging materials, used wireless device and accessories, and promote their recycling.

WEEE Approval

The wireless device is in compliance with the essential requirements and other relevant provisions of the Waste Electrical and Electronic Equipment Directive 2002/96/EC (WEEE Directive).

RoHS Approval

The wireless device is in compliance with the restriction of the use of certain hazardous substances in electrical and electronic equipment Directive 2002/95/EC (RoHS Directive).



Laws and Regulations Observance

Observe laws and regulations when using your wireless device. Respect the privacy and legal rights of the others.



Care and Maintenance

It is normal that your wireless device gets hot when you use or charge it. Before you clean or maintain the wireless device, stop all applications and power off the wireless device.

- I Use your wireless device and accessories with care and in clean environment. Keep the wireless device from a fire or a lit cigarette.
- I Protect your wireless device and accessories from water and vapor and keep them dry.
- I Do not drop, throw or bend your wireless device.
- I Clean your wireless device with a piece of damp and soft antistatic cloth. Do not use any chemical agents (such as alcohol and benzene), chemical detergent, or powder to clean it.
- I Do not leave your wireless device and accessories in a place with a considerably low or high temperature.
- I Use only accessories of the wireless device approved by the manufacture. Contact the authorized service center for any abnormality of the wireless device or accessories.
- I Do not dismantle the wireless device or accessories. Otherwise, the wireless device and accessories are not covered by the warranty.

Emergency Call

This wireless device functions through receiving and transmitting radio signals. Therefore, the connection cannot be guaranteed in all conditions. In an emergency, you should not rely solely on the wireless device for essential communications.

Specific Absorption Rate (SAR)

Your wireless device is a radio transmitter and receiver. It is designed not to exceed the limits for exposure to radio waves recommended by international guidelines. These guidelines were developed by the independent scientific organization ICNIRP and include safety margins designed to assure the protection of all persons, regardless of age and health.

The guidelines use a unit of measurement known as the Specific Absorption Rate, or SAR. The SAR limit for wireless devices is 2.0 W/kg and the highest SAR value for this device when tested complied with this limit.

Regulatory Information

The following approvals and notices apply in specific regions as noted.

CE Approval (European Union)

The wireless device is approved to be used in the member states of the EU. The wireless device is in compliance with the essential requirements and other relevant provisions of the Radio and Telecommunications Terminal Equipment Directive 1999/5/EC (R&TTE Directive).

Federal Communications Commission Notice (United States): Before a wireless device model is available for sale to the public, it must be tested and certified to the FCC that it does not exceed the limit established by the government-adopted requirement for safe exposure.

The SAR limit adopted by the USA and Canada is 1.6 watts/kilogram (W/kg) averaged over one gram of tissue. The highest SAR value reported to the FCC for this device type was compliant with this limit.

FCC Statement

This device complies with Part 15 of the FCC Rules. Operation is subject to the following two conditions: (1) this device may not cause harmful interference, and (2) this device must accept any interference received, including interference that may cause undesired operation.

The antenna(s) used for this transmitter must be installed to provide a separation distance of at least 20 cm from all persons.

Warning: Changes or modifications made to this equipment not expressly approved by HUAWEI may void the FCC authorization to operate this equipment.