

Datasheet

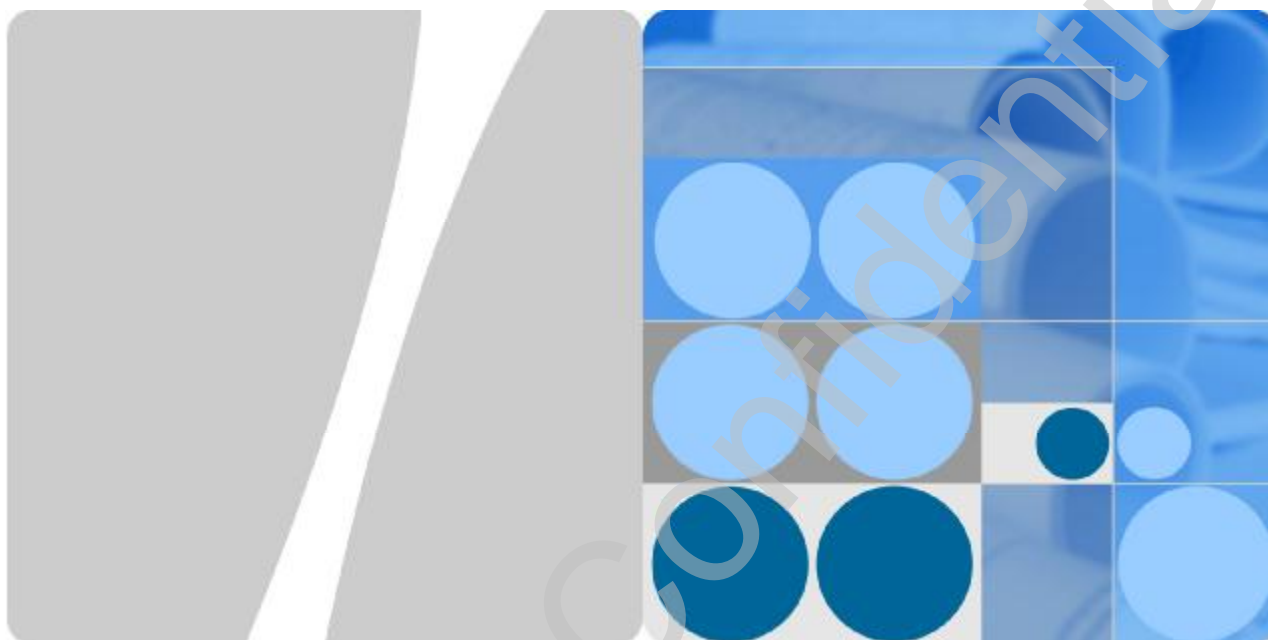

HUAWEI EM770W HSPA PC EMBEDDED
MODULE
V100R001

Issue 03
Date 2009-08-31



HUAWEI TECHNOLOGIES CO., LTD.

Huawei Technologies Co., Ltd. provides customers with comprehensive technical support and service. Please feel free to contact our local office or company headquarters.

Huawei Technologies Co., Ltd.

Address: Huawei Industrial Base
Bantian, Longgang
Shenzhen 518129
People's Republic of China

Website: <http://www.huawei.com>

Email: support@huawei.com

Copyright © Huawei Technologies Co., Ltd. 2008. All rights reserved.

No part of this document may be reproduced or transmitted in any form or by any means without prior written consent of Huawei Technologies Co., Ltd.

Trademarks and Permissions



and other Huawei trademarks are trademarks of Huawei Technologies Co., Ltd.

All other trademarks and trade names mentioned in this document are the property of their respective holders.

Notice

The information in this document is subject to change without notice. Every effort has been made in the preparation of this document to ensure accuracy of the contents, but all statements, information, and recommendations in this document do not constitute the warranty of any kind, express or implied.

About This Document

Summary

This document provides information about the major functions, supported services, system architecture, and technical references of HUAWEI EM770W HSPA PC Embedded Module.

The following table lists the contents of this document.

Chapter	Details
1 Overview	Describes the basic functions, key features, and hardware and software overview of the product.
2 Mechanical Specifications	Describes the mechanical specifications of the product.
3 Electrical Specifications	Describes the electrical specifications of the product.
4 RF Specifications	Describes the RF specifications of the product.
5 Software and Tools	Describes the software and tools of the product.
6 Test and Certification	Describes the information about test and certification of the product and notebook.
7 Technical Reference	Describes the technical references of the product.
Acronyms and Abbreviations	Lists the acronyms and abbreviations mentioned in this document.
Safety Information	Lists the safety information of using the product.
Reference Schematic	Lists the Reference Schematic of using the product.

History

Issue	Details	Date	Author	Approved By
01	Creation	2008-09-15	Tan Xiao'an	Xie Conglong
02	Modified	2009-06-20	Fred Luo	Xie Bingfeng
03	Modified	2009-08-31	Fred Luo	Xie Bingfeng

Contents

1 Overview	8
1.1 Introduction	8
1.2 Key Features.....	9
1.3 Hardware Overview.....	10
1.3.1 Hardware Logic Block Diagram	10
1.3.2 External Hardware Interfaces.....	11
1.4 Software Overview	13
2 Mechanical Specifications.....	15
2.1 Dimensions and interfaces.....	15
2.1.1 Dimensions and interfaces of the EM770W	15
2.1.2 Dimensions of the Mini PCI Express Connector.....	16
2.1.3 Dimensions of the Antenna Connector.....	17
2.2 Reliability.....	19
2.3 Temperature	19
3 Electrical Specifications	20
3.1 Mini PCI Express Pin Definition	20
3.2 Pin Descriptions	23
3.2.1 Digital Signal DC Characteristics.....	23
3.2.2 Power Sources and Grounds	24
3.2.3 USB Signals.....	25
3.2.4 USIM Signals.....	25
3.2.5 PCM Interface Signals	29
3.2.6 W_DISABLE# Signal.....	33
3.2.7 LED_WWAN# Signal.....	33
3.2.8 PERST# Signal.....	35
3.2.9 NC Pins	36
3.3 Power Supply and Consumption.....	36
3.3.1 Power Supply.....	36
3.3.2 Power Consumption.....	36
3.3.3 Module Power Saving Mode Design Guide for Windows XP	40
4 RF Specifications	42
4.1 Operating Frequencies.....	42



4.2 Conducted RF Measurement.....	42
4.2.1 Test Environment	42
4.2.2 Test Standards	43
4.3 Conducted Rx Sensitivity and Tx Power.....	43
4.3.1 Conducted Receive Sensitivity	43
4.3.2 Conducted Transmit Power	43
4.4 Antenna Design Requirements	44
4.4.1 Antenna Design Indicators	44
4.4.2 Interference	48
4.4.3 Radio Test Environment	48
4.4.4 Design Recommendations	49
4.5 Offline Mode.....	50
5 Software and Tools	51
5.1 Firmware	51
5.1.1 Version Descriptions	51
5.2 Drivers	51
5.2.1 Windows Drivers.....	52
5.2.2 Linux Drivers.....	53
5.3 Dashboard	53
5.3.1 Windows Dashboard	53
5.3.2 Linux Dashboard.....	55
5.4 GPS	55
5.4.1 Introduction.....	55
5.4.2 Functionality.....	55
5.4.3 Performance	56
5.4.4 GPS Applet	57
5.5 Tools	64
5.5.1 Firmware Update Tool	64
5.5.2 Module Label Print Tool–MLT	68
5.5.3 Engineering Tools	78
5.5.4 Debugging Board.....	78
6 Test and Certification.....	85
6.1 Reliability Test for Module	85
6.1.1 Environmental Reliability Test.....	85
6.1.2 Mechanical Reliability Test	87
6.1.3 Temperature-Relevant Tests.....	88
6.2 Temperature Rise Test.....	90
6.2.1 Temperature Rise Test Result.....	90
6.3 TRP and TIS.....	99
6.3.1 Total Radiated Power	99
6.3.2 Total Isotropic Sensitivity	100

6.3.3 Intermediate Channel Relative Sensitivity.....	100
6.4 Product Certifications	101
6.5 Environmental Protection Certification and Test	101
6.5.1 RoHS.....	101
6.5.2 WEEE.....	103
6.5.3 PVC-free.....	103
6.6 National Compulsory Certification.....	103
6.6.1 Product Certification.....	103
6.6.2 Importance of Product Certification.....	104
6.6.3 Product Certification Test Items.....	104
6.6.4 Product Certification Classifications.....	104
6.6.5 Certification Modes	105
6.6.6 Certification Types.....	105
6.6.7 Guide to Product Certification.....	114
6.6.8 Nameplate	115
6.7 GCF and PTCRB.....	115
6.7.1 GCF Certification	116
6.7.2 PTCRB Certification.....	117
6.7.3 Overall-System Certification.....	118
7 Technical Reference.....	122
7.1 Layer 1 Specifications (Physical)	122
7.2 Layer 2 Specifications (MAC/RLC).....	122
7.3 Layer 3 Specifications (RRC).....	122
7.4 Layer 3 NAS/Core Network (MM/CM).....	122
7.5 GSM Protocol Specifications.....	123
7.6 GPRS Protocol Specifications.....	123
7.7 General Specifications.....	123
7.8 Performance/Test Specifications.....	124
7.9 SIM Specifications	124

1 Overview

1.1 Introduction

HUAWEI EM770W HSPA PC Embedded Module (hereinafter referred to as the EM770W) is a HSPA Wireless Wide Area Network (WWAN) PC module. It is a multi-mode wireless terminal for business professionals.

The EM770W supports the following standards:

- | High Speed Packet Access(HSPA)
- | Universal Mobile Telecommunications System (UMTS)
- | Enhanced Data Rates for Global Evolution (EDGE)
- | General Packet Radio Service (GPRS)
- | Global System for Mobile Communications (GSM)

The EM770W provides the following services:

- | HSPA/UMTS packet data service
- | EDGE/GPRS packet data service
- | WCDMA/GSM short message service (SMS)

The EM770W can be connected to a PC via the Mini PCI Express interface. In the service area of the HSPA, UMTS, EDGE, GPRS or GSM network, you can surf the Internet, send messages and emails, and receive messages/emails cordlessly. The EM770W is fast, reliable, and easy to operate. Thus, mobile users can experience many new features and services with the EM770W. These features and services will enable a large number of users to use the EM770W and the average revenue per user (ARPU) of operators will increase substantially.

Figure 1-1 shows the profile of the EM770W.

Figure 1-1 Profile of the EM770W



1.2 Key Features

Table 1-1 lists the key features of the EM770W.

Table 1-1 Key features of the EM770W

Feature	EM770W
HSPA/UMTS 2100 MHz	Y
HSPA/UMTS 1900 MHz	Y
HSPA/UMTS 1700 MHz	N
HSPA/UMTS 900 MHz	Y
HSPA/UMTS 850 MHz	Y
HSPA/UMTS 800 MHz	N
GSM/GPRS/EDGE 850/900/1800/1900 MHz	Y
UMTS equalizer and receive diversity	Y
HSDPA data service of up to 7.2 Mbit/s	Y
HSUPA data service of up to 5.76 Mbit/s	Y
UMTS PS domain data service of up to 384 kbps	Y

Feature	EM770W
EDGE packet data service of up to 236.8 kbps	Y
GPRS packet data service of up to 85.6 kbps	Y
CS domain data service based on UMTS and GSM	Y
SMS based on the CS/PS domain of GSM and WCDMA	Y
Unstructured Supplementary Service Data (USSD)	Y
GPS(GPS Standalone)	Y
AGPS(Assisted GPS)	O
PCM interface	O
Mini PCI Express 1.2 interface	Y
Windows 2000/Windows XP/Windows Vista/Windows 7/Linux 2.6.18 or later versions	Y

Notes:

Y: The feature is supported.

O: The feature is optional.

N: The feature is NOT supported.

1.3 Hardware Overview

The hardware of the EM770W consists of three sections: baseband section, power management (PM) section, and radio frequency (RF) section. External interfaces include the antenna interface and the Mini PCI Express interface.

1.3.1 Hardware Logic Block Diagram

The EM770W is completed on a single-board. Figure 1-2 shows the hardware functional block diagram.

Figure 1-2 Hardware functional block diagram

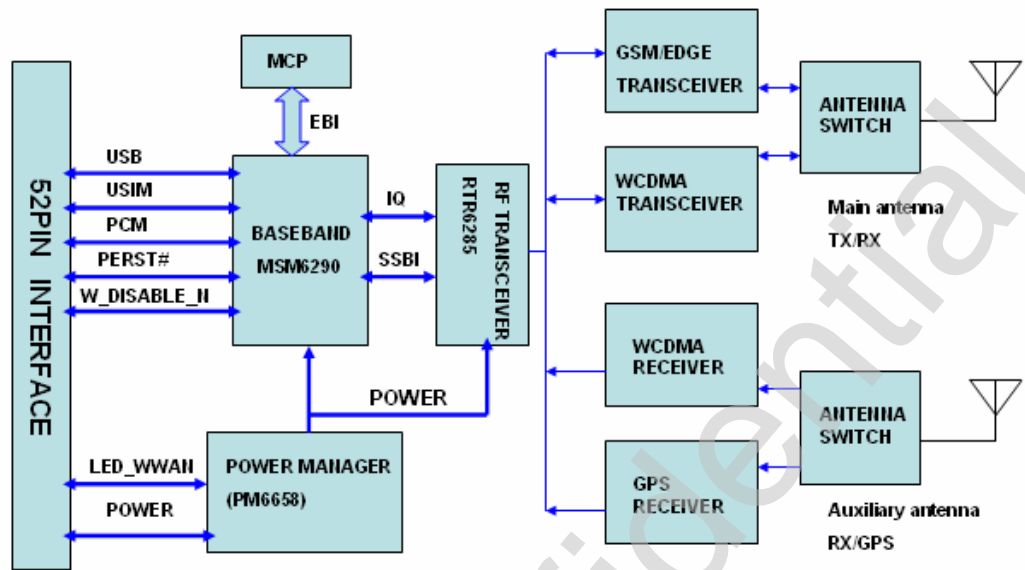

The circuitry of the EM770W consists of three sections: baseband section, RF section, and PM section.

- I The baseband section includes the baseband processor and SDRAM/flash MCP. It implements baseband signals processing, wireless protocols, and management of various peripheral devices.
- I The RF section includes the RF transceiver, PA, antenna switches, duplexer, and antenna interfaces, and it supports receive diversity.
- I The PMU section includes PM IC and DC-DC circuits, providing the power supply and power management for the whole module.

1.3.2 External Hardware Interfaces

1. Antenna interface

The EM770W has a main antenna connector and an auxiliary antenna connector.

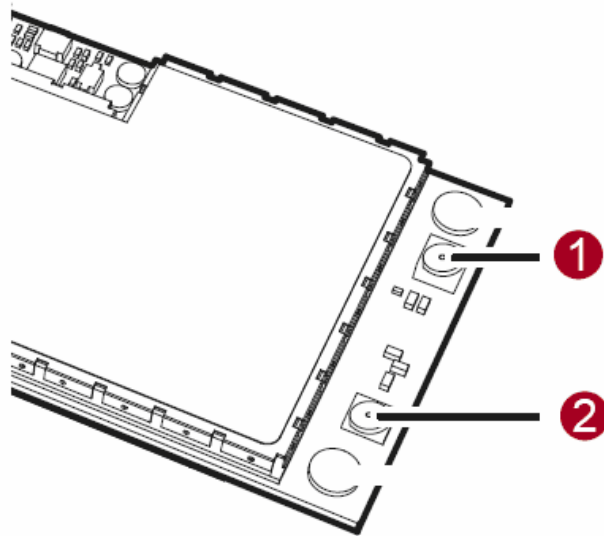

- ❶ Auxiliary antenna connector (labeled with **A** on the PCB)
- ❷ Main antenna connector (labeled with **M** on the PCB)

2. Mini PCI Express interface

The interface of the EM770W is a standard Mini PCI Express interface. The EM770W consists of several major signals, as shown in the following figure.

Figure 1-3 Mini PCI Express identification

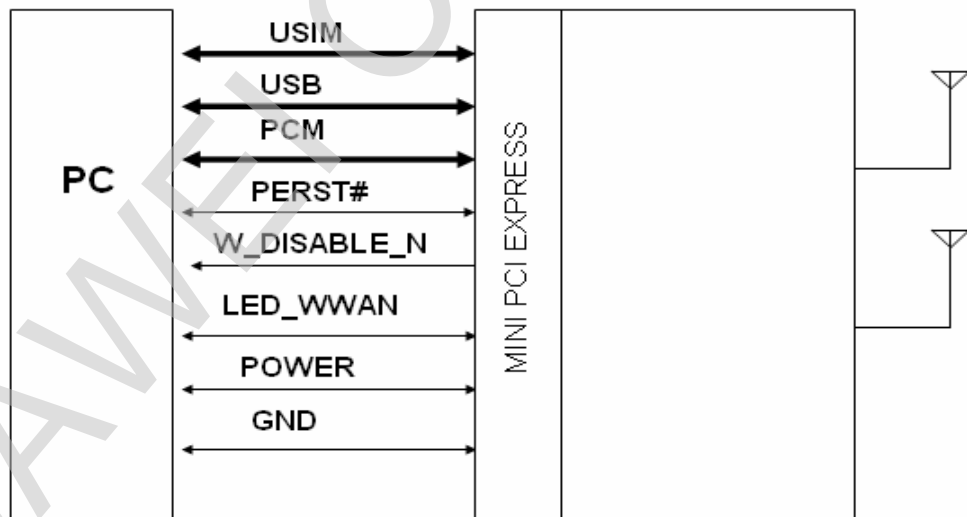

- USIM interface: The USIM interface provides the interface for a USIM card. The USIM card can be inserted into the PC.
- USB interface: The USB interface supports three modes of USB 2.0 (low speed, full speed, and high speed). Because there is not a separate USB-controlled voltage bus, USB functions implemented on EM770W which are expected to report as self-powered devices.
- PCM interface: The PCM interface provides interface for external codecs.
- Auxiliary signals: The auxiliary signals provide some other functions.

- Power sources and grounds: The PCI Express Mini Card provides two power sources, including the one at 3.3 Vaux (3.3Vaux) and the one at 1.5 V(+1.5 V). The EM770W uses the 3.3 voltage as the power supply.

1.4 Software Overview

Figure 1-4 Software logic block diagram

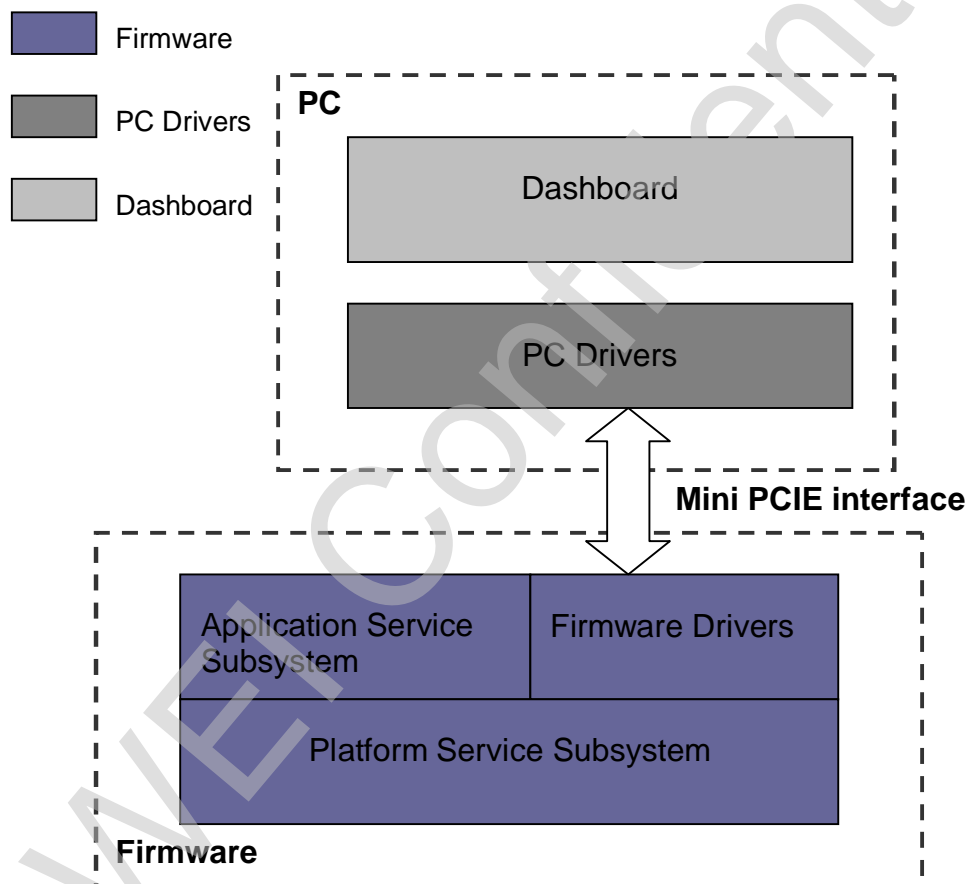

Descriptions of the functional modules in the system architecture are as follows.

Firmware Drivers

The firmware drivers include drivers of the RF module, flash, and all the peripherals such as the SIM card and USB device.

Platform Service Subsystem

The platform service subsystem initializes programs, diagnoses, downloads data, and serves as a watchdog.

Application Service Subsystem

The application service subsystem consists of various application services and a WCDMA-GSM dual mode protocol stack. Application services handle the commands and data sent from PC side according to service categories, and deliver them to the protocol stack. The protocol stack communicates with the network side to process the commands and data, and returns response from network to application services. Finally, application services return responses to PC side.

The main application services are as follows:

- I Call management service
- I SMS service
- I CS/PS data service

PC Drivers

The PC drivers are used to implement functions such as the interaction between the dashboard and the firmware.

Dashboard

The dashboard enables the PC side to display the interfaces of initiating or answering a call, and sending and receiving messages. It provides the interface for CS/PS domain network accessing and periodically refreshes the interface of the current USB modem status. The interface is provided to the end users.

2 Mechanical Specifications

2.1 Dimensions and interfaces

2.1.1 Dimensions and interfaces of the EM770W

The dimensions of the EM770W are 51 mm (length) × 30 mm (width) × 5 mm (height), which comply with the standard dimensions specified in the *PCI Express Mini Card Electromechanical Specification Revision 1.2*. Figure 2-1 shows the dimensions of the EM770W in details.

Figure 2-1 Dimensions of the EM770W

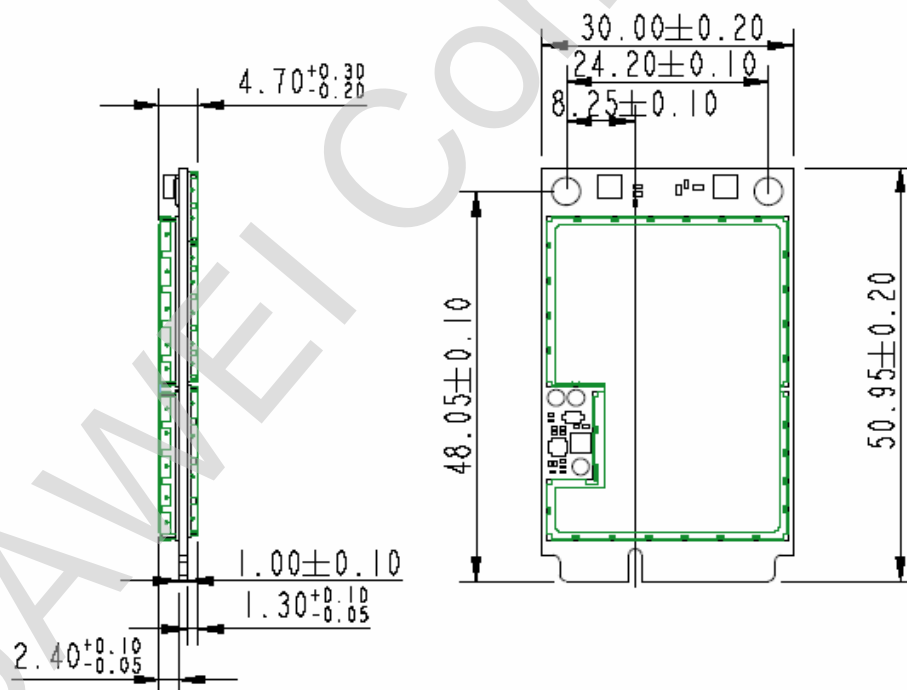
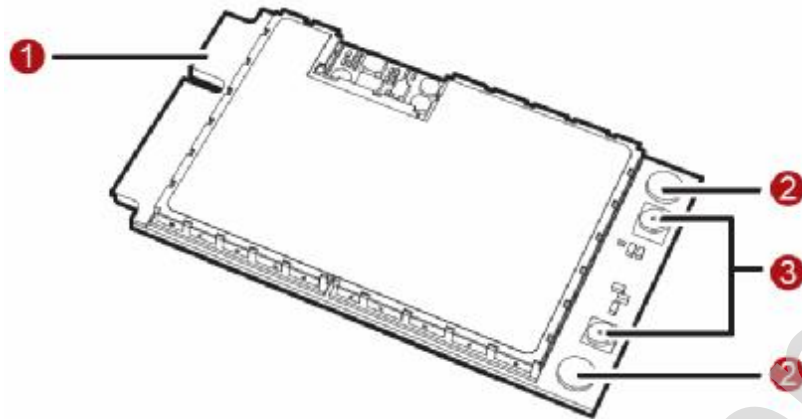

Figure 2-2 shows the appearance of the interfaces on the EM770W.

Figure 2-2 Appearance of the interfaces on the EM770W



① Mini PCI Express connector

It is used to connect the EM770W to the WWAN Mini PCI Express interface of the PC.

② Screw holes

They are used to fix the EM770W on the main board of the PC with screws.

③ Antenna interfaces

They are used to connect to antennas. Auxiliary antenna and main antenna are combined to support receive diversity. The receive diversity can strengthen the received RF signal quality and improve RF performance, and whether to open or close the receive diversity function can be controlled by software.

Notes:

It is strongly recommended adding auxiliary antenna when designing PC with the EM770W.

2.1.2 Dimensions of the Mini PCI Express Connector

The EM770W adopts a standard Mini PCI Express connector that has 52 pins and complies with the *PCI Express Mini Card Electromechanical Specification Revision 1.2*.

Figure 2-3 shows a 52-pin Mini PCI Express connector (take the Molex 67910002 as an example).

Figure 2-3 Dimensions of the Mini PCI Express connector

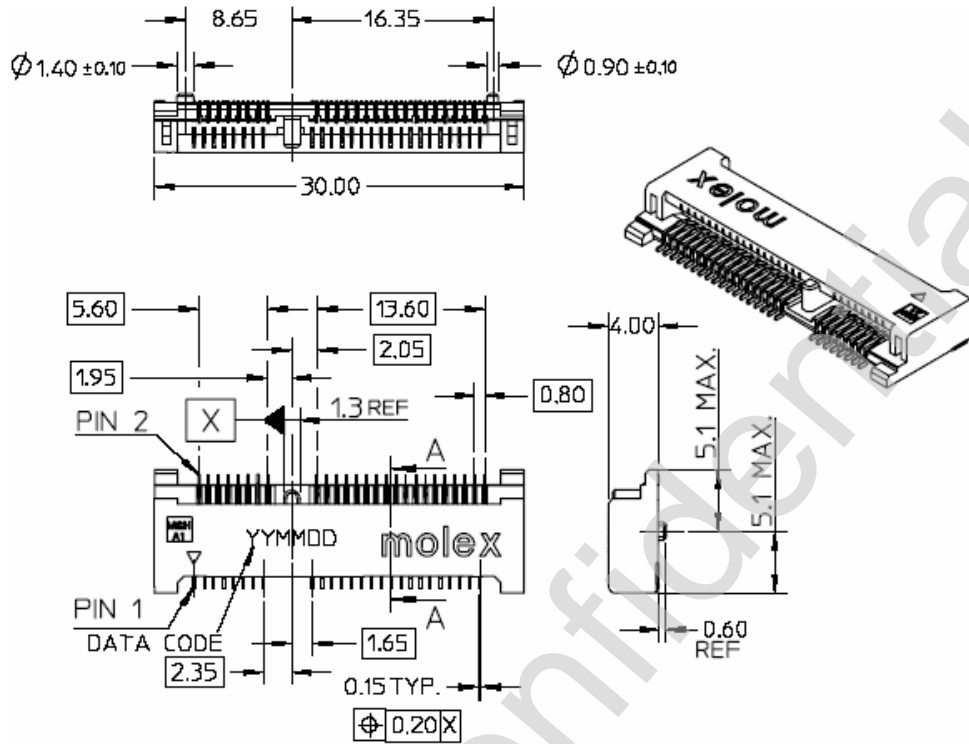

2.1.3 Dimensions of the Antenna Connector

The EM770W provides an interface for connecting an external antenna. The external antenna is connected to the module through the coaxial connector that is the Hirose U.FL-R-SMT-1(10) (you can get to know Hirose U.FL-R-SMT-1(10) by visiting the website http://www.hirose-connectors.com/products/U.FL_1.htm).

Figure 2-4 Dimensions of the antenna connector

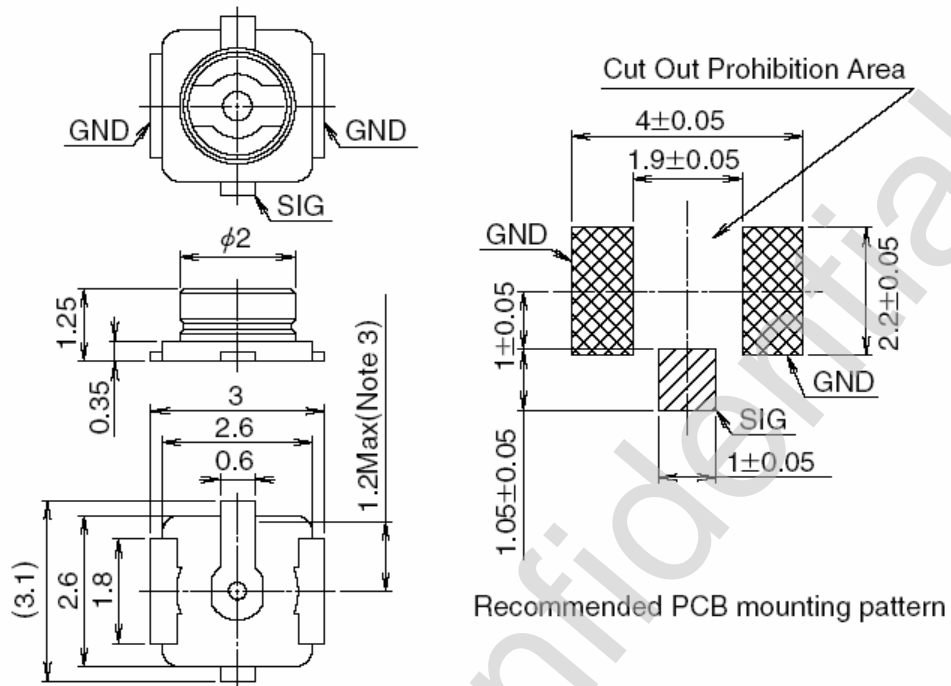

Figure 2-5 shows the specifications of the antenna mating connectors (take the ones with the Hirose part number as U.FL-LP as examples).

Figure 2-5 Specifications of the antenna mating connectors

	U.FL-LP-040	U.FL-LP-055	U.FL-LP(W)-040	U.FL-LP-052	U.FL-LP-085
Part No.					
Mated Height	2.5mm Max. (2.4mm Nom.)	2.5mm Max. (2.4mm Nom.)	2.6mm Max. (1.9mm Nom.)	2.4mm Max. (2.2mm Nom.)	2.4mm Max. (2.3mm Nom.)
Applicable cable	Dia. 0.81mm Coaxial cable	Dia. 1.13mm and Dia. 1.32mm Coaxial cable	Dia. 0.81mm Coaxial cable	Dia. 1mm Coaxial cable	Dia. 1.37mm Coaxial cable

For more information about Hirose Ltd., SMD connectors, and mating connectors, visit the website of Hirose <http://www.hirose-connectors.com>.

2.2 Reliability

Table 2-1 Requirements on the environment reliability

Test Case		Standard	
Environment reliability	Operational	High temperature	IEC60068-2-2
		High temperature	IEC60068-2-1
		Random vibration	MIL-STD-810F-METHOD 514.5
		Shock vibration	ANSI/TIA-603-C-2004 -3.3.5
		Sine sweep vibration	ANSI/TIA-603-C-2004 -3.3.4
	Non-operational	High temperature	IEC60068-2-2
		Low temperature	IEC60068-2-1
		Damp heat, cyclic	IEC60068-2-30
		Thermal shock	IEC60068-2-14
		Salt-fog	IEC60068-2-11
		Drop	IEC 60068-2-32
		Durability	EIA-364-9

2.3 Temperature

Table 2-2 Operating and storage temperature

Description	Minimum	Maximum	Unit
Operating temperature	-10	+55	°C
Operating temperature (reduced RF performance)	-20	+65	°C
Storage temperature	-40	+85	°C

3 Electrical Specifications

3.1 Mini PCI Express Pin Definition

The physical connections and signal levels of the EM770W comply with PCI Express Mini CEM specifications. Device operations comply with USB 2.0 specifications.

Table 3-1 lists the Mini PCI Express connector pins out of the EM770W.

Table 3-1 Definition of mini PCI Express pins

Definition of the EM770W Mini PCI Express pins				
Pin No.	Mini PCI Express Standard Description	HUAWEI Pin Description	Additional Description	Direction to Module
1	WAKE#	NC	Not connected.	-
2	3.3Vaux	VCC_3V3	3.3 V DC supply rails from the PC side.	Input
3	COEX1	NC	Not connected.	-
4	GND	GND	Mini Card ground.	-
5	COEX2	NC	Not connected.	-
6	1.5 V	NC	Not connected.	-
7	CLKREQ#	NC	Not connected.	-
8	UIM_PWR	UIM_PWR	Power source for the external UIM/SIM card.	Output
9	GND	GND	Mini Card ground.	-
10	UIM_DATA	UIM_DATA	External UIM/SIM data signal.	Input/Output
11	REFCLK-	NC	Not connected.	-
12	UIM_CLK	UIM_CLK	External UIM/SIM clock signal.	Output
13	REFCLK+	NC	Not connected.	-

Definition of the EM770W Mini PCI Express pins				
Pin No.	Mini PCI Express Standard Description	HUAWEI Pin Description	Additional Description	Direction to Module
14	UIM_RESET	UIM_RESET	External UIM/SIM reset signal.	Output
15	GND	GND	Mini Card ground.	-
16	UIM_Vpp	NC	Not connected.	-
17	Reserved	NC	Not connected.	-
18	GND	GND	Mini Card ground.	-
19	Reserved	NC	Not connected.	-
20	W_DISABLE#	W_DISABLE_N	For ending the wireless communications	Input
21	GND	GND	Mini Card ground.	-
22	PERST#	PERST#	For forcing a hardware reset on the card.	Input
23	PERn0	NC	Not connected.	-
24	3.3Vaux	NC	Not connected.	-
25	PERp0	NC	Not connected.	-
26	GND	GND	Mini Card ground.	-
27	GND	GND	Mini Card ground.	-
28	1.5 V	NC	Not connected.	-
29	GND	GND	Mini Card ground.	-
30	SMB_CLK	NC	Not connected.	-
31	PETn0	NC	Not connected.	-
32	SMB_DATA	NC	Not connected.	-
33	PETp0	NC	Not connected.	-
34	GND	GND	Mini Card ground.	-
35	GND	GND	Mini Card ground.	-
36	USB_D-	USB_D-	USB signal D-.	Input/Output
37	GND	GND	Mini Card ground.	-
38	USB_D+	USB_D+	USB signal D+.	Input/Output

Definition of the EM770W Mini PCI Express pins				
Pin No.	Mini PCI Express Standard Description	HUAWEI Pin Description	Additional Description	Direction to Module
39	3.3Vaux	VCC_3V3	3.3V DC supply rail from the PC side.	Input
40	GND	GND	Mini Card ground.	-
41	3.3Vaux	VCC_3V3	3.3V DC supply rail from the PC side.	Input
42	LED_WWAN#	LED_WWAN	Active-low LED signal for indicating the state of the card.	Output
43	GND	GND	Mini Card ground.	-
44	LED_WLAN#	NC	Not connected.	-
45	Reserved	PCM_CLK	PCM clock	Output
46	LED_WPAN#	NC	Not connected.	-
47	Reserved	PCM_DOUT	PCM data output	Output
48	1.5 V	NC	Not connected	-
49	Reserved	PCM_DIN	PCM_data input	Input
50	GND	GND	Mini Card Ground	-
51	Reserved	PCM_SYNC	PCM frame synchronization	Output
52	3.3Vaux	VCC_3V3	3.3V DC supply rail from the PC side.	Input

3.2 Pin Descriptions

3.2.1 Digital Signal DC Characteristics

Table 3-2 Digital signal DC characteristics

Symbol	Description	Minimum	Maximum	Unit	Notes
V_{IH}	High-level input voltage, CMOS/Schmitt	$0.7 \cdot V_{DD_X}$	$V_{DD_X} + 0.3$	V	1
V_{IL}	Low-level input voltage, CMOS/Schmitt	-0.3	$0.3 \cdot V_{DD_X}$	V	1
V_{OH}	High-level output voltage, CMOS	$V_{DD_X} - 0.5$	V_{DD_X}	V	1
V_{OL}	Low-level output voltage, CMOS	0	0.4	V	1
I_{IH}	Input high leakage current	-	1	μA	1
I_{IL}	Input low leakage current	-1	-	μA	1
I_{IHPD}	Input high leakage current with pull-down	10	60	μA	1
I_{ILPU}	Input low leakage current with pull-up	-60	-10	μA	1
I_{OZH}	High-level, three-state leakage current	-	1	μA	1
I_{OZL}	Low-level, three-state leakage current	-1	-	μA	1
I_{OZHPD}	High-level, three-state leakage current with pull-down	10	60	μA	1
I_{OZLPU}	Low-level, three-state leakage current with pull-up	-60	-10	μA	1
C_{IN}	Input capacitance	-	7	pF	1, 2

Notes:

1. Table 3-2 lists the universal specifications of the signals. Any difference from the universal specifications is listed in the relevant chapter or section.
2. The input capacitance value is guaranteed by design and not completely tested.

3.2.2 Power Sources and Grounds

The PCI Express Mini Card provides two power sources: one is 3.3Vaux (3.3 Vaux) and the other is 1.5V (+ 1.5 V). For the EM770W, +3.3Vaux is the only supply voltage available. The input voltage is 3.3 V ± 9%, as specified by PCI Express Mini CEM Specifications 1.2.

Table 3-3 Power and ground specifications

Name	Pins	Minimum	Type	Maximum
VCC	2, 39, 41, and 52	3.0 V	3.3 V	3.6 V
GND	4, 9, 15, 18, 21, 26, 27, 29, 34, 35, 37, 40, 43, and 50	0 V		

Notes:

To minimize the RF radiation through the power lines, it is suggested to add ceramic capacitors of 10pF, and 100nF to the ground beside the Mini PCI Express connector on the host side.

The PCI Express Mini CEM specification states that PERST# is deasserted minimum 1 ms after 3.3Vaux has been applied and is stable. The module will generate an on board power on reset signal and will remain in reset condition until PERST# is deasserted.

After de-assertion of PERST#, the module will boot up. USB D+ becomes high when booting is completed, simultaneously the module starts to communicate with PC via USB. Figure 3-1 shows power up timing.

During PC suspend state, it's better to keep VCC available to avoid startup delays occurred when power down the module.

Figure 3-1 Power up timing

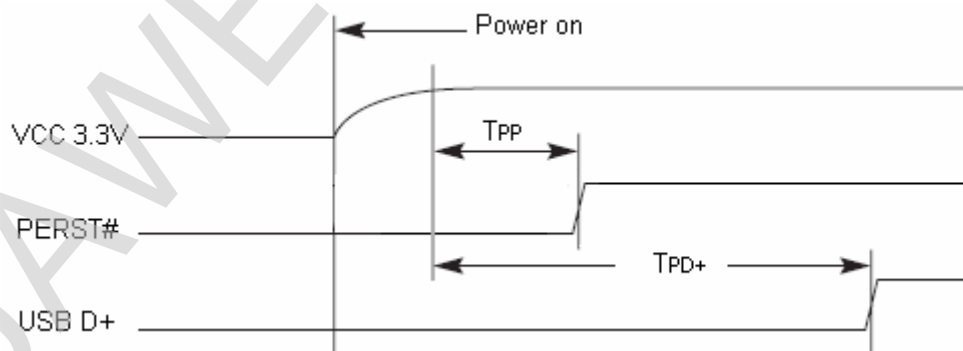

Table 3-4 Power up timing

Parameter	Comments	Time(Nominal values)	Units
T _{PP}	Power Valid to PERST# de-assert	1	ms
T _{PD+}	Power Valid to USB D+ high	3.45	sec.

If PC need to detect the PID/VID of module during the BIOS phase, the detect time should exceed the T_{PD+} time.

3.2.3 USB Signals

The EM770W is compliant with USB 2.0 specification. It supports full-speed(12Mbit/s) and high-speed(480Mbit/s) when acting as a peripheral and supports low-speed, full-speed, and high-speed when acting as a host. The USB 2.0 specifications allow peripherals to support any one or more of these speeds. To ensure best performance, the PC USB host controller should support high-speed mode also when using EM770W USB high-speed mode.

Table 3-5 USB pins

Name	Pin	Description	Direction to Module
USB D-	36	USB data signal D-	Input/Output
USB D+	38	USB data signal D+	Input/Output

Notes:

To minimize the RF radiation through the PCI-E interface, you can add a 33 pF ceramic capacitor to ground on every pin of the PCI-E on the host side except USB D+/D-.

The USB interface is powered directly from the 3.3 V supply. The USB input/output lines are compatible with the USB 2.0 3.3 V signal specifications.

Table 3-6 USB signal DC characteristics

V_{OHmin}	V_{OLmax}	V_{IHmin}	V_{ILmax}
2.8V	0.3V	2V	0.8V

The high-speed signal characteristics according to the Eye Pattern Templates of the USB 2.0 signal specification.

3.2.4 USIM Signals

The USIM is a smart card for UMTS/GSM cellular applications. The USIM provides the required subscription information to allow the mobile equipment to attach to a GSM or UMTS network. The USIM also provides the subscriber's verification procedures as well as authentication methods for network authentication during the attach procedures.

Table 3-7 USIM pins

Pin	Name	Description	Direction to Module
8	UIM_PWR	Power source for the external UIM/SIM.	Output
10	UIM_DATA	External UIM/SIM data signal.	Input/Output
12	UIM_CLK	External UIM/SIM clock signal.	Output
14	UIM_RESET	External UIM/SIM reset signal.	Output
16	UIM_Vpp	Programming power connection used to program EEPROM of first generation ICCs, but not used now.	Not connected

Notes:

It is recommended that the SIM card is inserted only after the power of the module is disconnected, otherwise the SIM card can be destroyed.

USIM interface schematic reference

There is no SIM card interface circuit in the EM770W module, and users need to add the USIM interface circuit. Figure 3-2 shows the definition of interface signals and the typical USIM interface schematic.

Figure 3-2 USIM interface schematic on PC

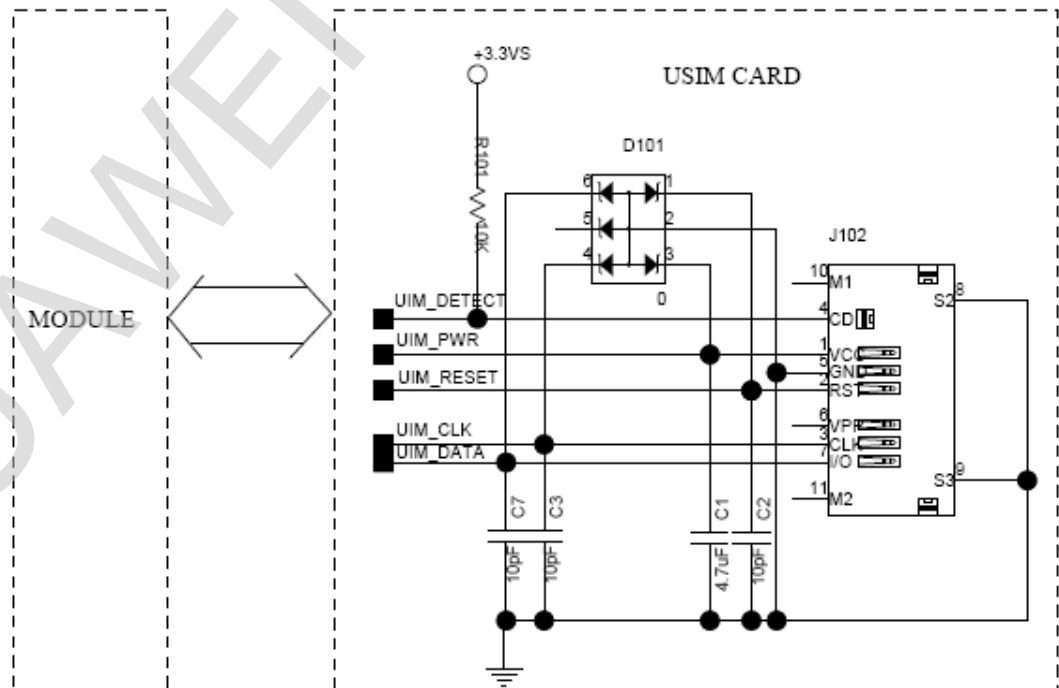

Design guide

The USIM signals are connected to the Mini PCI Express card connector (the card edge connector) and pass through an EMI filtering and ESD protection circuit on the module board before entering the EM770W processor. There is also an EMI filtering and ESD protection circuit between SIM card interface and Mini PCI interface on the user's board.

1. Power supply

The SIM interface is powered by an internal LDO regulator of EM770W. The default value of this regulator is 2.85 V. The power of the regulator is programmable in the range of 1.5 V to 3.05 V and is expected to be set to 3.0 V or 1.8 V.

2. Modem signals

After a power-on or reset, the USIM signals are activated to detect if a SIM card is present and to initialize it if it exists. Once a card has been detected and initialized, the interface is always on. However, the clock signal is only activated when data is actually being transferred. The USIM signals from the module are connected to the level translators and then to the Mini Card host connector.

- ┆ UIM_DETECT pin is optional, according to whether need this function.
- ┆ UIM_DATA needn't add pull-up resistance, it has been pulled up to UIM_PWR by a 15 kΩ resistor on the module, as the standard ISO/IEC 7816-3 recommends.
- ┆ UIM_PWR need add additional decoupling capacitors (range 1uF-10μF,typevalue 4.7uF),also 10pF capacitor are placed on the signals UIM_RST, UIM_CLK and UIM_DATA each.

These levels exceed those required in ISO/IEC 7816-3.

3. SIM signals

The following data is taken from ETSI standard Specification of the 3 Volt Subscriber Identity Module - Mobile Equipment (SIM-ME) interface (GSM 11.12 version 4.3.1).

Table 3-8 SIM RST requirements

RST	Minimum	Maximum
V _{IL}	0	0.2V _{cc}
V _{IH}	0.7V _{cc}	V _{cc}

Table 3-9 SIM CLK requirements

CLK	Minimum	Maximum
V _{IL}	0	0.2V _{cc}
V _{IH}	0.7V _{cc}	V _{cc}

Table 3-10 SIM IO requirements

IO	Minimum	Maximum
V _{IL}	0	0.4
V _{IH}	0.7V _{cc}	V _{cc}
V _{OL}	-0.3	0.2 V _{cc}
V _{OH}	0.7 V _{cc}	V _{cc} +0.3

Notes:

The V_{OL}max of 0.45 V for the outputs is specified at an output current of 3 mA whereas the V_{IL}max of 0.4 V for the SIM IO input is specified at an input current of 1 mA. With the smaller current drive, the output voltage would be driven lower than the stated maximum value.

4. ESD protection

Since the SIM is a CMOS device, ESD protection devices should be placed near to the SIM connector to provide protection before connecting to the module. In addition, all the SIM interface signals should be bypassed with a 10 pF capacitor.

The used ESD device (PESD3V3L5UY, NXP) in reference schematic is a low capacitance 5-fold ESD protection diode arrays in SOT363 package.

5. Clock frequency

The SIM must support clock frequencies between 1 MHz and 4 MHz. (The Mini Card can be programmed to generate a clock of 1.625 MHz, 2.6 MHz, or 3.25 MHz).

6. Routing recommendations

The SIM interface signals consist of four signals that are UIM_PWR, UIM_RST, UIM_CLK, and UIM_DATA (UIM_Vpp isn't connected also not used in many applications). Due to the relatively low clock frequencies involved, the concern is not the degradation of the SIM signals themselves. The main concern is routing of the SIM interface signals through areas considered to be of high risk for RF noise coupling (crosstalk and RF contamination) which can desensitize the radio circuitry. The general guidelines that should be followed are listed as follows:

- | It is recommended that these signals should be routed over a contiguous ground plane.
- | SIM interface signals should not be routed near high transient signals (power supply chokes and DC/DC switching FETs).
- | Avoid routing of these signals near output connectors.
- | Keep SIM interface signals isolated from other signals. 2x width spacing (1.5x min) between SIM interface signals and all other signal routing is recommended.

Certification test

Using test equipment simulates a (U)SIM card to test U(SIM) protocol in GCF or PTCRB test, Some strange issues may be encountered during SIM/USIM test, please contact with Huawei for more details.

3.2.5 PCM Interface Signals

The PCM interface can be used in two modes:

- I Primary PCM that runs at 2.048MHz(short frame sync)
- I Auxiliary PCM that runs at 128KHz(long frame sync)

They both support linear, μ -law and A-law codecs match the sync timing and run in master mode. The default mode of EM770W is primary PCM with linear codec.

Both the PCM interface modes, primary and auxiliary, use the same pins. The PCM pin assignment is shown in Table 3-11.

Table 3-11 PCM Pins

Pin	Name	Primary PCM functionality	Auxiliary PCM functionality	Description	Direction to Module
45	PCM_CLK	PRIM_PCM_CLK	AUX_PCM_CLK	PCM clock	Output
47	PCM_DATA_OUT	PRIM_PCM_DATA_OUT	AUX_PCM_DATA_OUT	PCM data output	Output
49	PCM_DATA_IN	PRIM_PCM_DATA_IN	AUX_PCM_DATA_IN	PCM data input	Input
51	PCM_SYNC	PRIM_PCM_SYNC	AUX_PCM_SYNC	PCM frame synchronization	Output

Primary PCM interface (2.048MHz)

The PCM codec port operates with a 2.048MHz clock and the PCM_SYNC runs at 8KHz with a 50% duty cycle.

Figure 3-3 PRIM_PCM_SYNC timing

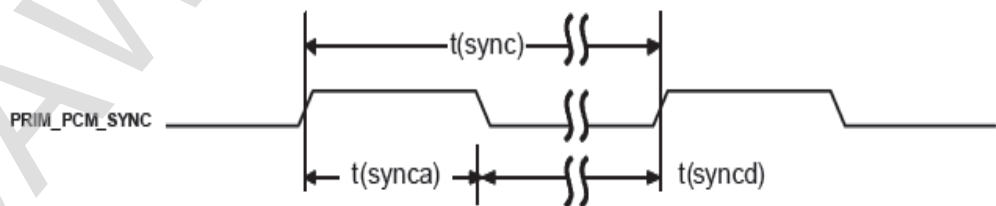

Figure 3-4 PRIM_PCM_DIN codec to module timing

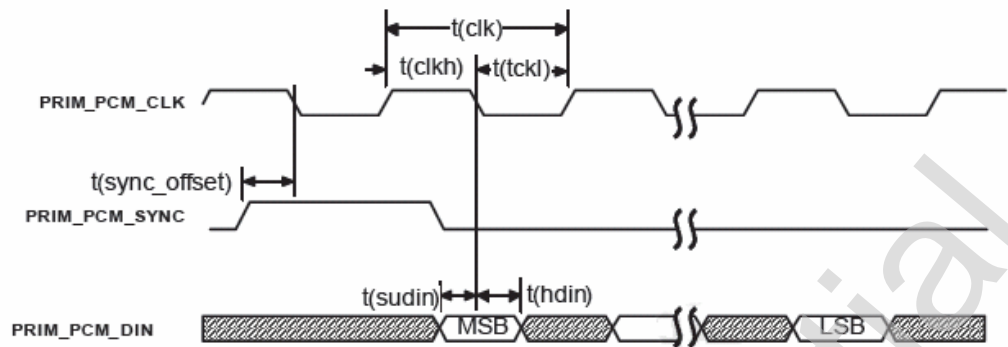

Figure 3-5 PRIM_PCM_DOUT module to codec timing

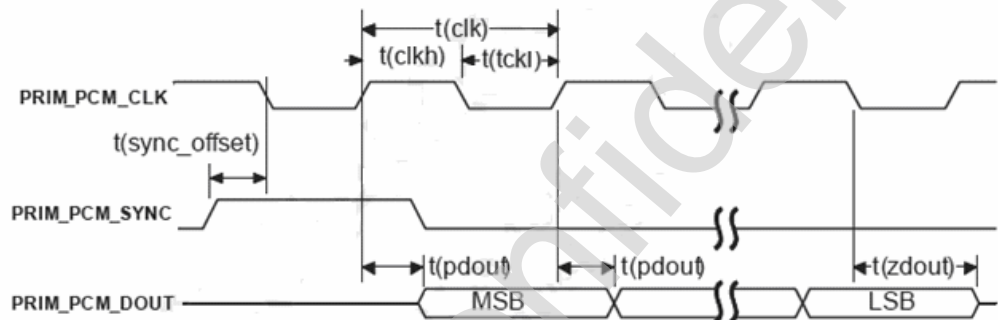

Table 3-12 Primary PCM timing parameters

Parameter	Description	Min	Typical	Max	Unit	Note
t(sync)	PRIM_PCM_SYNC cycle time(PCM_SYNC_DIR=1)	-	125	-	μs	
	PRIM_PCM_SYNC cycle time(PCM_SYNC_DIR=0)	-	125	-	μs	
t(synca)	PRIM_PCM_SYNC asserted time(PCM_SYNC_DIR=1)	-	488	-	ns	2
	PRIM_PCM_SYNC asserted time(PCM_SYNC_DIR=0)	-	-	-	ns	
t(syncd)	PRIM_PCM_SYNC de-asserted time(PCM_SYNC_DIR=1)	-	124.5	-	μs	3
	PRIM_PCM_SYNC de-asserted time(PCM_SYNC_DIR=0)	-	-	-	μs	
t(clk)	PRIM_PCM_CLK cycle time(PCM_CLK_DIR=1)	-	488	-	ns	4
	PRIM_PCM_CLK cycle time(PCM_CLK_DIR=0)	-	-	-	ns	
t(clkh)	PRIM_PCM_CLK high time(PCM_CLK_DIR=1)	-	244	-	ns	1,5
	PRIM_PCM_CLK high time(PCM_CLK_DIR=0)	-	-	-	ns	
t(clkl)	PRIM_PCM_CLK low time(PCM_CLK_DIR=1)	-	244	-	ns	1,5

Parameter	Description	Min	Typical	Max	Unit	Note
	PRIM_PCM_CLK low time(PCM_CLK_DIR=0)	-	-	-	ns	
t(sync_offset)	PRIM_PCM_SYNC offset time to PRIM_PCM_CLK falling	-	122	-	ns	6
	PCM_SYNC_DIR=1,PCM_CLK_DIR=1					
	PRIM_PCM_SYNC offset time to PRIM_PCM_CLK falling	-	-	-	ns	
	PCM_SYNC_DIR=0,PCM_CLK_DIR=0					
t(sudin)	PRIM_PCM_DIN setup time to PRIM_PCM_CLK falling	60	-	-	ns	
t(hdin)	PRIM_PCM_DIN hold time after PRIM_PCM_CLK falling	60	-	-	ns	
t(pdout)	Delay from PRIM_PCM_CLK rising to PRIM_PCM_DOUT valid	-	-	60	ns	
t(zdout)	Delay from PRIM_PCM_CLK falling to PRIM_PCM_DOUT High-Z	5	-	60	ns	

Notes:

- 1 t(clkh) and t(clkl) are independent of PCM_CLK_SENSE.
- 2 One t(clk) period.
- 3 PRIM_PCM_SYNC cycle time minus one t(clk) period.
- 4 t(clk)= 1/(2.048 MHz).
- 5 PRIM_PCM_CLK high or low time = t(clk)/2±10 ns.
- 6 PRIM_PCM_SYNC offset time = t(clk)/4.

Auxiliary PCM interface (128kHz)

The auxiliary PCM interface enables communication with an external codec to support hands-free applications. Linear,μ-law, and A-law codecs are supported by the auxiliary PCM interface.

The auxiliary codec port operates with standard long-sync timing and a 128 kHz clock. The PCM_SYNC runs at 8 kHz with a 50% duty cycle. Most μ-law, and A-law codecs support the 128 kHz PCM_CLK bit clock.

Figure 3-6 AUX_PCM_SYNC timing

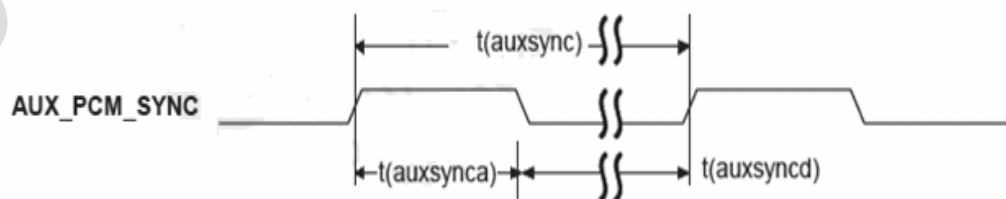

Figure 3-7 AUX_PCM_DIN codec to module timing

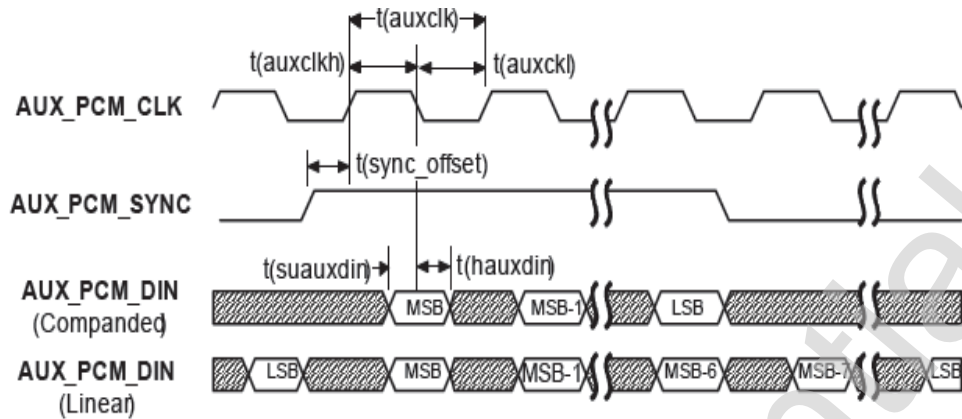

Figure 3-8 AUX_PCM_DOUT module to codec timing

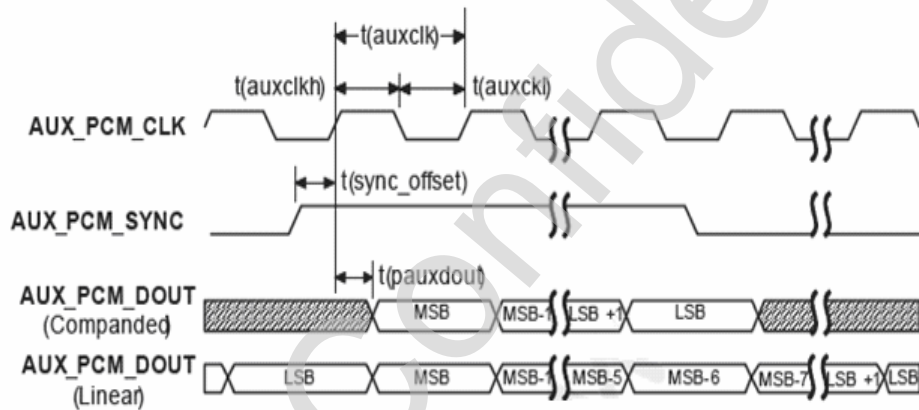

Table 3-13 Auxiliary PCM timing parameters

Parameter	Description	Min	Typical	Max	Unit	Note
t(auxsync)	AUX_PCM_SYNC cycle time	-	125	-	μs	
t(auxsynca)	AUX_PCM_SYNC asserted time	-	62.5	-	μs	1
t(auxsyncd)	AUX_PCM_SYNC de-asserted time	-	62.5	-	μs	1
t(auxclk)	AUX_PCM_CLK cycle time	-	7.8	-	μs	2
t(auxclkh)	AUX_PCM_CLK high time	-	3.9	-	μs	3
t(auxckl)	AUX_PCM_CLK low time	-	3.9	-	μs	3
t(sync_offset)	AUX_PCM_SYNC offset time to AUX_PCM_CLK rising	-	1.95	-	μs	4
t(suauxdin)	AUX_PCM_DIN setup time to AUX_PCM_CLK Falling	60	-	-	ns	
t(hauxdin)	AUX_PCM_DIN hold time after AUX_PCM_CLK Falling	60	-	-	ns	
t(pauxdout)	Propagation delay from AUX_PCM_CLK AUX_PCM_DOUT valid	-	-	60	ns	

Notes:

- 1 t(auxsync)/2 ± 10 ns.
- 2 t(auxclk)= 1/(128 kHz).

3 t(auxclk)/2 ± 10 ns.
 4 t(auxclk)/4 ± 10 ns.

3.2.6 W_DISABLE# Signal

The W_DISABLE# signal is provided to allow users to disable wireless communications add-in cards. When the W_DISABLE# signal is asserted, all radios should be disabled. When the W_DISABLE# signal is not asserted, the radio may transmit if not disabled by other means such as software.

The W_DISABLE# signal is an active low signal with internal 100 kΩ pull-up resistor that should disable radio operation when being asserted (driven low) by the system.

Due to the potential of a software disable state, the combination of the software state and W_DISABLE# assertion state must be determined before the normal operation is resumed. Table 3-15 lists this requirement on the function of W_DISABLE# and the software control setting. For example, the radio RF operation remains disabled unless both the hardware and software are set to enable the RF features of the card.

Table 3-14 W_DISABLE_N signal

Pins	Name	Description	Direction to Module
20	W_DISABLE_N	Close wireless communications	Input

Table 3-15 Radio operational states

W_DISABLE#	SW Control Setting*	Radio Operation
High	Enabled	Enabled
High	Disabled	Disabled
Low	Enabled	
Low	Disabled	

* This control setting is implementation specific; this column represents the collective intention of the host software to manage radio operation.

Notes:

It is strongly recommended that you control this pin via hot-keys or a hardware switch. There are three points as bellow:

1. If you do not turn off the radio manually, the radio will be on when the module is powered on.
2. End users need turn off radio at some situation like on an airplane.
3. According to Mini-PCIE specification, radio must be turned off through hardware or software. Nearly all PC companies obey this specification.

3.2.7 LED_WWAN# Signal

The LED_WWAN signal of the EM770W can tolerate up to the voltage of 5 V and absorb the current up to 150 mA. According to the given circuit, in order to reduce the current of the LED, a resistance of 1 kΩ must be placed in series with the LED.

Table 3-16 LED_WWAN signal

Pins	Name	Description	Additional Description	Direction to Module
42	LED_WWAN	Active-low LED signal for indicating the status of the module.	L: Light on H: Light off	Output

This signal is used to display the state of WWAN. The reference circuit diagram is shown in the following figure.

Figure 3-9 LED_WWAN# signal reference circuit diagram

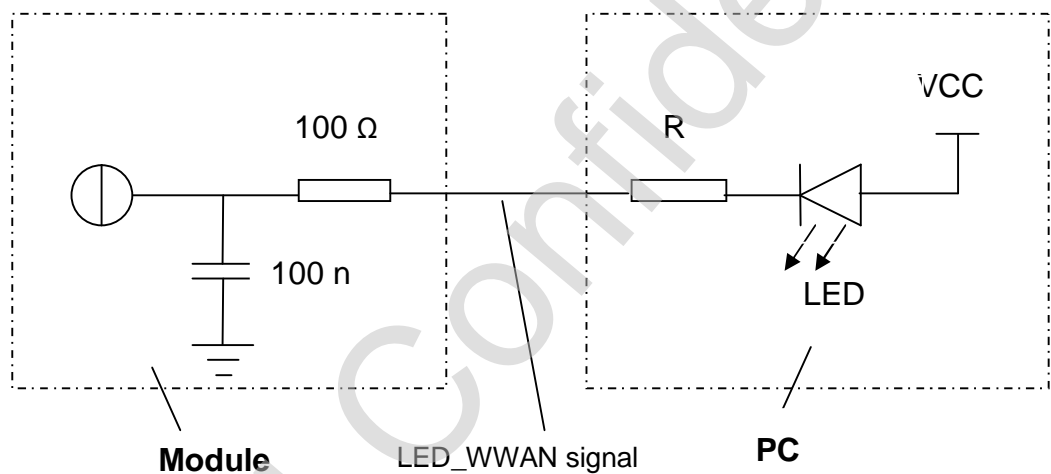

Notes:

Normally when the HUAWEI module is enabled, the LED is light on, and when disabled, the LED is light off. The wink mode of the LED can be customized by the demand of the client.

For resistance of R placed on PC, choose the value such that it satisfies the following equation:

$$I_F \cdot R + V_F + I_F \cdot 100 = V_{CC}$$

V_F : Forward Voltage

I_F : Forward current

Take the LED 19-213/GVC-AMNB/3T as an example (Its manufacturer is Everlight Electronics., Ltd. and the website is <http://www.everlight.com>). Figure3-10 shows its I_F - V_F curves. If VCC is 5V and the desired current through the LED I_F is 3mA, then the voltage of the LED V_F is 1.5V according to I_F - V_F curves, the corresponding value for resistance of R is $(5 - 0.003 \cdot 100 - 1.5) / 0.003 = 1067 \Omega$.

The brightness of the LED depends on the current value, and for most of the indicator lights the current from 2mA to 5mA is already enough.

Figure 3-10 LED Typical Electro-Optical Characteristics Curves

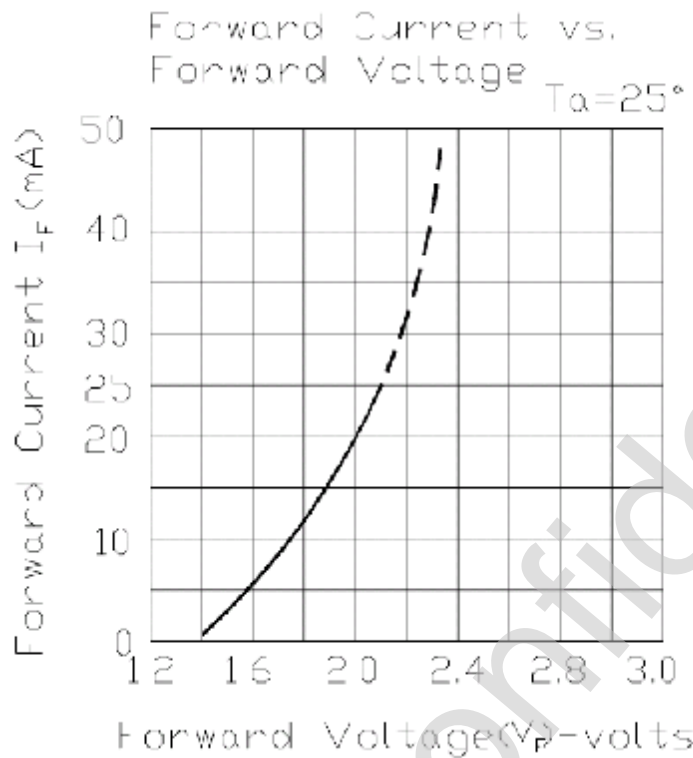

3.2.8 PERST# Signal

The PERST# signal has an internal pull-up. The active low input is used to hard reset the module.

The PERST# signal is de-asserted by the host to indicate that system power sources are within the specified voltage tolerance and are stable. PERST# can be asserted by the host when power is switched off and also can be used by the system to force a hardware reset on the card. However, a hardware reset is not required during normal operation and may only be used in case of module malfunction.

A hard reset of the module will result in a surprise removal of the module on the USB controller and cause the operating system to unload the device drivers. This will lead to a delay before the operating system discovers the device again. To avoid this delay, the PERST# pin should not be used in normal operation or in standby mode.

Table 3-17 PERST# signal

Pins	Name	Description	Additional Description	Direction to Module
22	PERST#	Force a hardware reset on the card.	H: normal or standby. L: Reset the module.	Input

3.2.9 NC Pins

The NC pins are not internally connected in the EM770W.

3.3 Power Supply and Consumption

3.3.1 Power Supply

The EM770W is supplied by 3.3 V power source, which must satisfy all requirements of PCI Express Mini CEM specifications, such as voltage tolerance and peak and normal current. The detailed requirements are listed in Table 3-18.

Table 3-18 Power requirements

Power	Voltage Tolerance	Peak (Maximum)	Normal (Maximum)
3.3 V	±9%	2750 mA ¹	1100 mA

Notes:

1. In burst transmit mode of GSM/GPRS/EDGE, the instantaneous current of the module will exceed 2.75 A, which will pull down the power voltage temporarily and perhaps result in the reset of the module or host. In order to avoid this case, you can add a large bulk capacitor beside the module on the host side (at least two 330uF capacitors).

3.3.2 Power Consumption

The power consumptions of the EM770W in different scenarios are respectively listed in Table 3-19, Table 3-20 and Table 3-21.

Table 3-19 DC power consumption (HSPA/WCDMA)

Description	Band	Test Value	Units	Power (dBm)
WCDMA	Band I (IMT2100)	245.4	mA	1 dBm Tx Power
		353.2		10 dBm Tx Power
		598.7		24 dBm Tx Power
	Band II (PCS 1900)	261.7	mA	1 dBm Tx Power
		371.3		10 dBm Tx Power
		623.1		24 dBm Tx Power
	Band V (850M)	319.2	mA	1 dBm Tx Power
		356.1		10 dBm Tx Power
		600.5		24 dBm Tx Power
	Band VIII	320.3	mA	1 dBm Tx Power

Description	Band	Test Value	Units	Power (dBm)
	(900M)	361.9		10 dBm Tx Power
		563.3		24 dBm Tx Power
HSDPA	Band I (IMT2100)	304.3	mA	1 dBm Tx Power
		402.7		10 dBm Tx Power
		625.4		24 dBm Tx Power
	Band II (PCS 1900)	316.4	mA	1 dBm Tx Power
		429.2		10 dBm Tx Power
		708.6		24 dBm Tx Power
	Band V (850M)	391.4	mA	1 dBm Tx Power
		430.4		10 dBm Tx Power
		677.8		24 dBm Tx Power
	Band VIII (900M)	391.1	mA	1d Bm Tx Power
		423.5		10 dBm Tx Power
		633.6		24 dBm Tx Power
HSUPA	Band I (IMT2100)	333.1	mA	1 dBm Tx Power
		436.4		10 dBm Tx Power
		629.4		24 dBm Tx Power
	Band II (PCS 1900)	337.3	mA	1 dBm Tx Power
		451.5		10 dBm Tx Power
		708.4		24 dBm Tx Power
	Band V (850M)	393.2	mA	1 dBm Tx Power
		436.9		10 dBm Tx Power
		667.6		24 dBm Tx Power
	Band VIII (900M)	405.1	mA	1d Bm Tx Power
		437.7		10 dBm Tx Power
		619.2		24 dBm Tx Power

Table 3-20 DC power consumption (GSM/GPRS/EDGE)

Description	Test Value	Units	PCL	Configuration
GPRS850	419.6	mA	3	1 Up/1 Down
	548.3			2 Up/1 Down

Description	Test Value	Units	PCL	Configuration
	662.2	mA	15	4 Up/1 Down
	185.5			1 Up/1 Down
	239.7			2 Up/1 Down
	331.4			4 Up/1 Down
GPRS900	429.2	mA	5	1 Up/1 Down
	585.2			2 Up/1 Down
	685.1			4 Up/1 Down
	220.4	mA	11	1 Up/1 Down
	312.6			2 Up/1 Down
	471.2			4 Up/1 Down
GPRS1800	379.2	mA	0	1 Up/1 Down
	530.1			2 Up/1 Down
	730.7			4 Up/1 Down
	176.6	mA	11	1 Up/1 Down
	222.5			2 Up/1 Down
	279.4			4 Up/1 Down
GPRS1900	322.2	mA	0	1 Up/1 Down
	467.6			2 Up/1 Down
	645.7			4 Up/1 Down
	173.7	mA	11	1 Up/1 Down
	217.6			2 Up/1 Down
	269.9			4 Up/1 Down
EDGE850	271.9	mA	8	1 Up/1 Down
	399.6			2 Up/1 Down
	508.2			4 Up/1 Down
	184.4	mA	15	1 Up/1 Down
	237.4			2 Up/1 Down
	309.8			4 Up/1 Down
EDGE900	283.8	mA	8	1 Up/1 Down
	415.4			2 Up/1 Down
	533.7			4 Up/1 Down

Description	Test Value	Units	PCL	Configuration
	185.5	mA	15	1 Up/1 Down
	240.4			2 Up/1 Down
	314.5			4 Up/1 Down
EDGE1800	289.5	mA	2	1 Up/1 Down
	395.6			2 Up/1 Down
	504.1			4 Up/1 Down
	199.5	mA	10	1 Up/1 Down
	225.7			2 Up/1 Down
	287.7			4 Up/1 Down
EDGE1900	258.9	mA	2	1 Up/1 Down
	373.1			2 Up/1 Down
	471.1			4 Up/1 Down
	176.8	mA	10	1 Up/1 Down
	223.2			2 Up/1 Down
	280.4			4 Up/1 Down

Table 3-21 DC power consumption(Idle and Suspend)

Scenario	Idle ¹		Suspend		Unit
	Offline Enabled	Offline Disabled	Offline Enabled	Offline Disabled	
WCDMA 2100MHz DRX = 8 (2.56 s)	91.6	98.3	2.90	4.32	mA
GSM 900MHz MFRM = 5 (1.18 s)	93.2	102	2.90	4.58	mA

Notes:

- 1 In idle mode, the module is registered to the network, USB bus is active, no voice or data call connection is ongoing.
- 2 The above values are the average of some test samples.

3.3.3 Module Power Saving Mode Design Guide for Windows XP

When Huawei module is idle, the driver of the module use USB feature 'selective suspend' to make USB device (the module) suspended, then the module will change to power saving mode (sleep).

But there are some problems when you use USB feature 'selective suspend' in Windows XP. If different USB devices are connected to the same USB host, only when all of the devices are idle, the host could let all the devices be suspended together. Once one or more devices are working, all of these devices could not be suspended.

Figure 3-11 shows this situation. In the figure, there is a USB camera is connected to the same USB host with Huawei module, so the module could not change to power saving mode.

The Microsoft official declaration about this problem refers to the following link, http://www.microsoft.com/whdc/connect/usb/usbfaq_intermed.mspx.

Figure 3-11 Different devices are connected to the same USB host

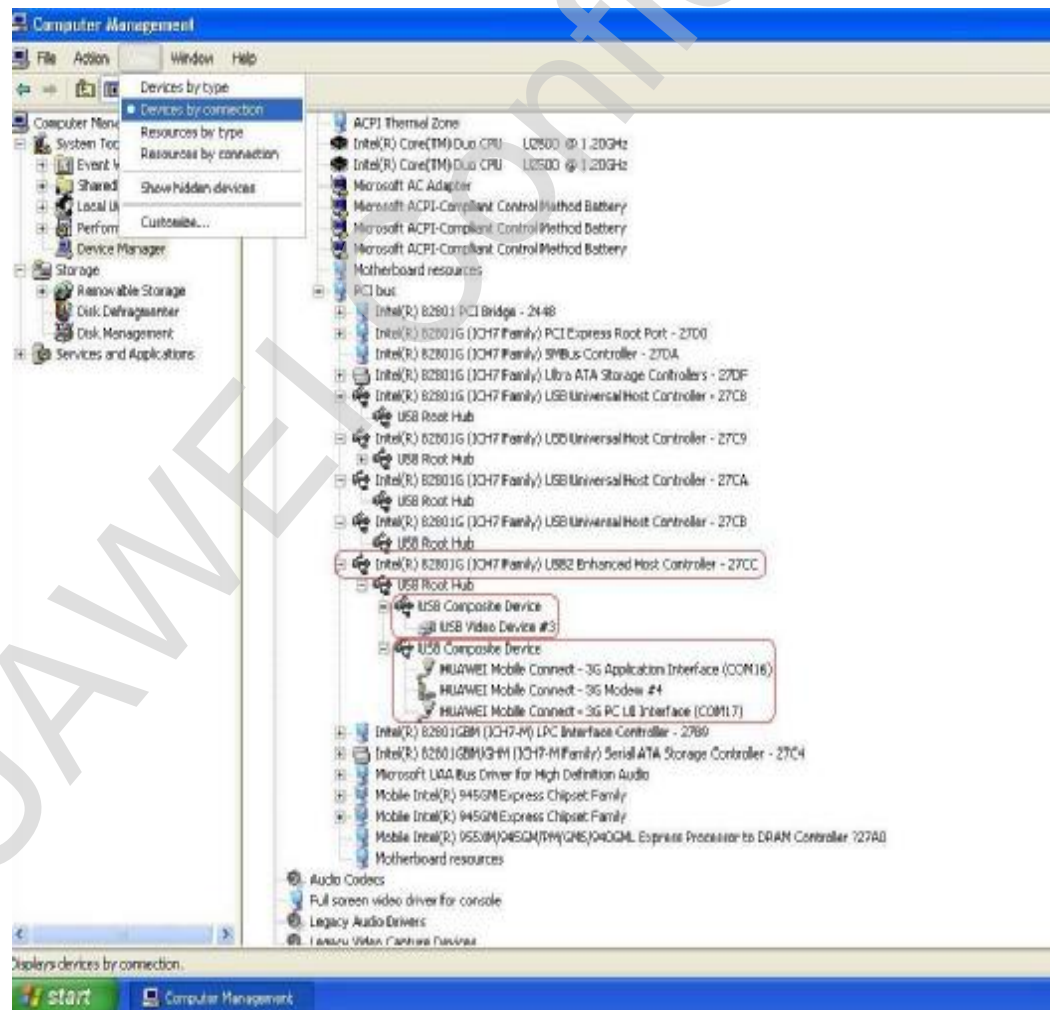

But in Figure 3-12, Huawei module and the USB camera is connected to different USB hosts, so they can be suspended separately. In this situation, Huawei module could change to power saving mode.

Figure 3-12 Different devices are connected to different USB hosts

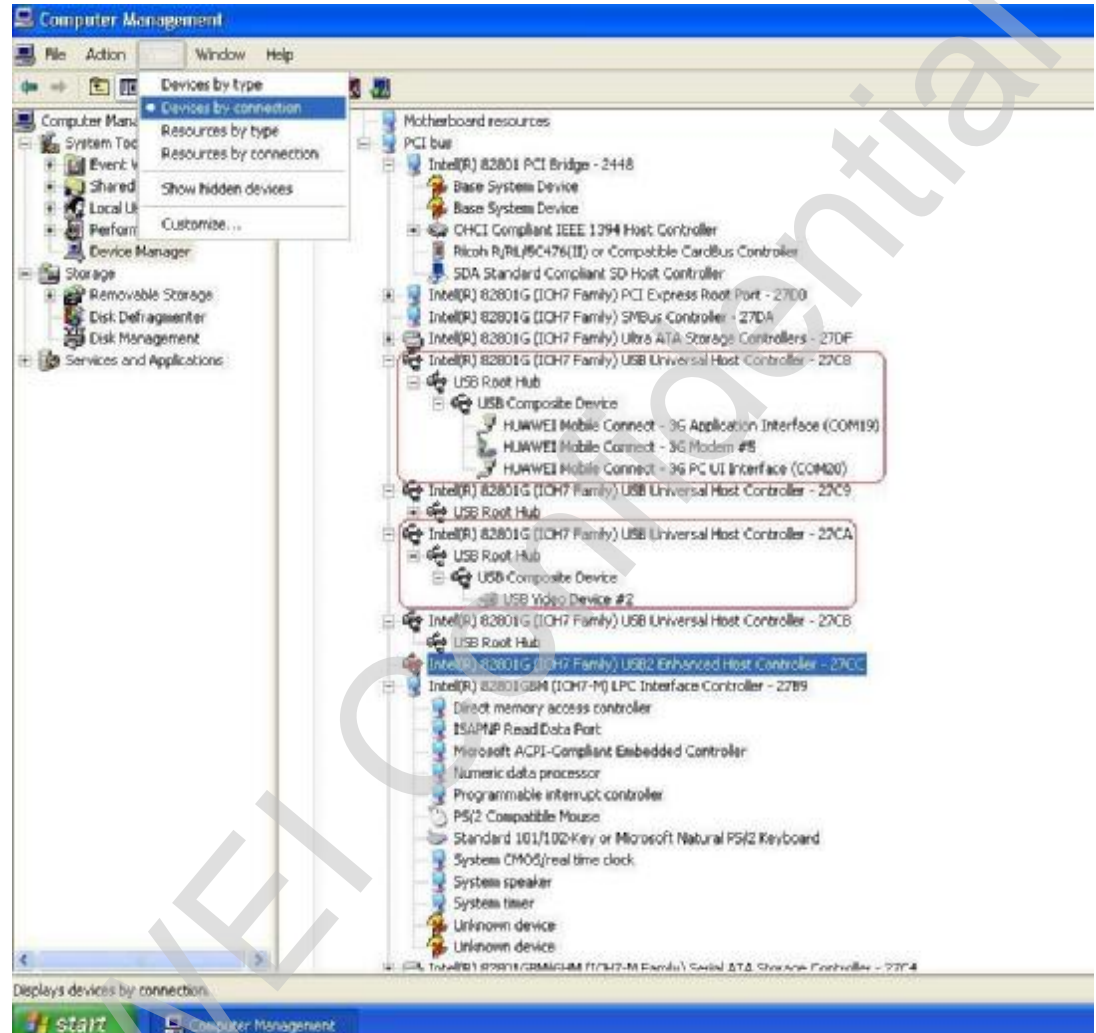

So if a laptop with Windows XP OS has any USB device (camera and so on), please make sure Huawei module and the USB device are connected to different USB hosts, otherwise the module maybe could not change to power saving mode.

4 RF Specifications

4.1 Operating Frequencies

Table 4-1 shows the RF bands supported by EM770W.

Table 4-1 RF bands

Operating Band	Tx	Rx
UMTS 2100 (Band I)	1920–1980 MHz	2110–2170 MHz
UMTS 1900 (Band II)	1850–1910 MHz	1930–1990 MHz
UMTS 850 (Band V)	824–849 MHz	869–894 MHz
UMTS 900 (Band VIII)	880–915 MHz	925–960 MHz
GSM 850	824–849 MHz	869–894 MHz
GSM 900	880–915 MHz	925–960 MHz
GSM 1800(DCS)	1710–1785 MHz	1805–1880 MHz
GSM 1900(PCS)	1850–1910 MHz	1930–1990 MHz
GPS	1574.42–1576.42 MHz	

4.2 Conducted RF Measurement

4.2.1 Test Environment

Test instrument:

R&S CMU200

Power supply:

KEITHLEY 2306

RF cable for testing:

L08-C014-350 of DRAKA COMTEQ or Rosenberger

Cable length: 29 cm

Compensation for WCDMA 850 MHz or WCDMA 900 MHz: 0.6 dB

Compensation for WCDMA 2100 MHz or WCDMA 1900 MHz: 0.8 dB

Notes:

The compensation for different frequency bands relates to the cable and the test environment. The instrument compensation needs to be set according to the actual cable conditions.

4.2.2 Test Standards

Huawei modules meet all 3GPP test standards relating to both 2G and 3G. Each module passes strict tests in factory; and thus the quality of the modules is guaranteed.

4.3 Conducted Rx Sensitivity and Tx Power

4.3.1 Conducted Receive Sensitivity

The conducted receive sensitivity is a key parameter that indicates the receiver performance of the EM770W. The conducted receive sensitivity means the weakest signal that the EM770W at the antenna port can receive. The BER must meet the 3GPP protocol requirements in the case of the minimum signal.

The **3GPP Protocol Claim** column in Table 4-2 lists the required minimum values, and the **Test Value** column lists the tested values of the EM770W.

Table 4-2 EM770W conducted Rx sensitivity

Item	3GPP Protocol Claim	Test Value ²	Unit
GSM850 (CS, 2.43% ¹)	<-102	-109	dBm
GSM900 (CS, 2.43%)	<-102	-109	dBm
DCS (CS, 2.43%)	<-102	-109	dBm
PCS (CS, 2.43%)	<-102	-109	dBm
BAND I (0.1%)	<-106.7	-110	dBm
BAND II (0.1%)	<-104.7	-108	dBm
BAND V(0.1%)	<-104.7	-109	dBm
BAND VIII (0.1%)	<-103.7	-109	dBm

Notes:

- 1 % = Bit Error Rate or Block Error Rate.
- 2 The test values are the average of some test samples.

4.3.2 Conducted Transmit Power

The conducted transmit power is another indicator that measures the performance of the EM770W. The conducted transmit power means the maximum power that the

EM770W tested at the antenna port can transmit. According to the 3GPP protocol, the required transmit power varies with the power class.

Table 4-3 lists the required ranges of the conducted transmit power of the EM770W. The tested values listed in the **Test Value** column must range from the minimum power to the maximum power.

Table 4-3 EM770W conducted Tx power

Item	Minimum Power Required in the 3GPP Protocol	Maximum Power Required in the 3GPP Protocol	Test Value ²	Unit
GSM850 (CS)	31	35	32.5	dBm
GSM850 (PS)	25	29	26.5	dBm
GSM900 (CS)	31	35	32.5	dBm
GSM900 (PS)	25	29	26.7	dBm
DCS (CS)	28	32	29.5	dBm
DCS (PS)	24	28	25.4	dBm
PCS (CS)	28	32	29.5	dBm
PCS (PS)	24	28	25.2	dBm
BAND I	21	25	24.1	dBm
BAND II	21	25	22.5	dBm
BAND V	21	25	23.5	dBm
BAND VIII	21	25	23.8	dBm

4.4 Antenna Design Requirements

4.4.1 Antenna Design Indicators

Antenna Efficiency

Antenna efficiency is the ratio of the input power to the radiated or received power of an antenna. The radiated power of an antenna is always lower than the input power due to the following antenna losses: return loss, material loss, and coupling loss. The efficiency of an antenna relates to its electrical dimensions. To be specific, the antenna efficiency increases with the electrical dimensions. In addition, the transmission cable from the antenna port of the EM770W to the antenna is also part of the antenna. The cable loss increases with the cable length and the frequency. It is recommended that the cable loss should be as low as possible, for example, U.FL-LP-088 made by HRS.

The following antenna efficiency (free space) is recommended for the EM770W on a laptop to ensure high radio performance of the EM770W:

- | Efficiency of the master antenna > 40% (−4 dB)
- | Efficiency of the slave antenna > 40% (−4 dB)
- | Efficiency of the GPS antenna > 50% (−3 dB)
- | Efficiency of the Wi-Fi antenna > 40% (−4 dB)

Isolation

For a wireless device with multiple antennas, the power of different antennas is coupled with each other. Antenna isolation is used to measure the power coupling. The power radiated by an antenna might be received by an adjacent antenna, which decreases the antenna radiation efficiency and affects the running of other devices. To avoid this problem, evaluate the antenna isolation as sufficiently as possible at the early stage of antenna design.

Antenna isolation depends on the following factors:

- | Distance between antennas
- | Antenna type
- | Antenna direction

The master antenna must be placed as near as possible to the EM770W to minimize the cable length. The slave antenna needs to be installed perpendicularly to the master antenna. The slave antenna can be placed farther away from the EM770W. Antenna isolation can be measured with a two-port vector network analyzer.

The following antenna isolation is recommended for the antennas on laptops:

- | Isolation between master and slave antennas < −12 dB
- | Isolation between the master antenna and the GPS antenna < −15 dB
- | Isolation between the slave antenna and the Wi-Fi antenna < −15 dB

If a Wi-Fi module is installed on the laptop, the following measures must be taken to reduce mutual influence between the data card module and the Wi-Fi module:

- | Adding a bandpass filter to the Wi-Fi channel to filter the WCDMA, GSM850, GSM900, DCS, and PCS signals
- | Ensuring sufficient isolation between the master antenna of the data card module and the Wi-Fi antenna

Table 4-4 lists the requirements for the isolation between the master antenna and the Wi-Fi antenna in different frequency bands according to the interference suppression supported by the filter in different frequency bands.

Table 4-4 Isolation between the master antenna and the Wi-Fi antenna

Frequency Band	Transmit Frequency	Conducted Transmit Power (dBm)	Ant Isolator (dB)	Wi-Fi Front End Filter Attenuation (dB)
UMTS2100	1920–1980 MHz	24	11	34

UMTS1900	1850–1910 MHz	24	11	34
UMTS850	824–849 MHz	24	10	36
UMTS900	880–915 MHz	24	10	36
GSM850	824–849 MHz	33	18	36
GSM900	880–915 MHz	33	18	36
DCS	1710–1785 MHz	30	17	34
PCS	1850–1910 MHz	30	17	34

S11 or VSWR

S11 (return loss) indicates the degree to which the input impedance of an antenna matches the reference impedance (50 ohm). S11 shows the resonance feature and impedance bandwidth of an antenna. Voltage standing wave ratio (VSWR) is another expression of S11. S11 relates to the antenna efficiency. S11 can be measured with a vector analyzer.

The following S11 values are recommended for the antennas on laptops:

- | S11 of the master antenna < -6 dB
- | S11 of the slave antenna < -6 dB
- | S11 of the GSP antenna < -10 dB
- | S11 of the Wi-Fi antenna < -10 dB

Polarization

The polarization of an antenna is the orientation of the electric field vector that rotates with time in the direction of maximum radiation.

The linear polarization is recommended for the antennas on laptops.

Envelope Correlation Coefficient

The envelope correlation coefficient indicates the correlation between different antennas in a multi-antenna system (master antenna, diversity antenna, and MIMO antenna). The correlation coefficient shows the similarity of radiation patterns, that is, amplitude and phase, of the antennas. The ideal correlation coefficient of a diversity antenna system or a MIMO antenna system is 0. A small value of the envelope correlation coefficient between the master antenna and the slave antenna indicates a high diversity gain. The envelope correlation coefficient depends on the following factors:

- | Distance between antennas
- | Antenna type
- | Antenna direction

The antenna correlation coefficient differs from the antenna isolation. Sufficient antenna isolation does not represent a satisfactory correlation coefficient. For this reason, the two indicators need to be evaluated separately.

For the antennas on laptops, the recommended envelope correlation coefficient between the master antenna and the diversity antenna is smaller than 0.5.

Radiation Pattern

The radiation pattern of an antenna reflects the radiation features of the antenna in the remote field region. The radiation pattern of an antenna commonly describes the power or field strength of the radiated electromagnetic waves in various directions from the antenna. The power or field strength varies with the angular coordinates (θ and φ), but is independent of the radial coordinates.

The radiation pattern of half wave dipole antennas is the best to wireless terminals. The radiation pattern of half wave dipole antennas is omnidirectional in the horizontal plane, and the incident waves of base stations are often in the horizontal plane. For this reason, the receiving performance is optimal.

To improve the performance of diversity antennas, it is recommended that the radiation pattern of the slave antenna be complementary with that of the master antenna.

The following radiation patterns are recommended for the antennas on laptops:

- | Master antenna: omnidirectional
- | Slave antenna: complementary with the radiation pattern of the master slave
- | GPS antenna: omnidirectional
- | Wi-Fi antenna: omnidirectional

Gain and Directivity

The radiation pattern of an antenna represents the field strength of the radiated electromagnetic waves in all directions, but not the power density that the antenna radiates in the specific direction. The directivity of an antenna, however, measures the power density that the antenna radiates.

Gain, as another important parameter of antennas, correlates closely to the directivity. The gain of an antenna takes both the directivity and the efficiency of the antenna into account. The appropriate antenna gain prolongs the service life of relevant batteries.

The following antenna gain is recommended for antennas on laptops:

- | Gain of the master antenna ≤ 3 dBi
- | Gain of the slave antenna ≤ 3 dBi

Notes:

- 1 The antenna on a laptop consists of the antenna body and the relevant RF transmission cable. Take the RF transmission cable inside the laptop into account when measuring any of the preceding antenna indicators.
- 2 Huawei cooperates with various famous antenna suppliers who are able to make suggestions on antenna design, for example, Amphenol, Skycross, Pulse etc.

4.4.2 Interference

Besides the antenna performance, the interference inside the laptop also affects the radio performance (especially the TIS) of the module. To guarantee high performance of the module, the interference sources inside the laptop must be properly controlled.

On a laptop, there are various interference sources, such as the LCD, CPU, audio circuits, and power supply. All the interference sources emit interference signals that affect the normal operation of the module. For example, the module sensitivity can be decreased due to interference signals. Therefore, during the design, you need to consider how to lessen the effects of interference sources on the module. You can take the following measures: Use an LCD with optimized performance; shield the LCD interference signals; shield the signal cable of the laptop; or design filter circuits.

Huawei is able to make technical suggestions on radio performance improvement of the module.

4.4.3 Radio Test Environment

The antenna efficiency, antenna gain, radiation pattern, total radiated power (TRP), and TIS can be tested in a microwave testing chamber.

Huawei has a complete set of OTA test environment (SATIMO microwave testing chambers and ETS microwave testing chambers). The testing chambers are certificated by professional organizations and are applicable to testing at frequencies ranging from 380 MHz to 6 GHz. The test items are described as follows:

Passive Tests

- | Antenna efficiency
- | Gain
- | Pattern shape
- | Envelope correlation coefficient

Active Tests

- | **TRP:** GSM, WCDMA, CDMA, TD-SCDMA, and LTE systems
- | **TIS:** GSM, WCDMA, CDMA, TD-SCDMA, and LTE systems

Figure 4-1 shows the SATIMO microwave testing chamber.

Figure 4-1 SATIMO microwave testing chamber



4.4.4 Design Recommendations

Recommendations for Designing the Module Antennas

The design recommendations are as follows:

- I It is recommended that the module antennas are designed at the upper edge, left edge or right edge of the laptop screen. Designing the antenna at the upper edge is better.
- I Take the isolation and envelope correlation between the master antenna and the slave antenna into account when designing the antennas. Keep the slave antenna away from the master antenna as far as possible. Install the slave antenna perpendicularly to the master slave. See Figure 4-2, Install the master and slave antennas in positions 1 and 3 or 2 and 4 but not in positions 1 and 2 or 3 and 4.

Figure 4-2 Recommended antenna positions

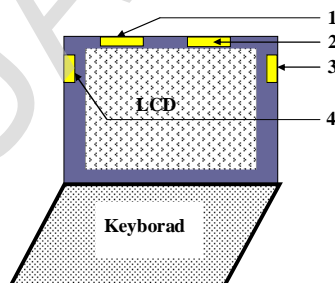

- I It is recommended to design the antenna pattern as the horizontal polarized omnidirectional pattern that facilitates the reception of strong signals especially in outdoor environments.
- I Besides the module antennas, a laptop has other internal antennas, such as the WLAN antenna. Therefore, when designing the module antennas, the requirement on the isolation between module antennas and other laptop antennas should be considered. Keep proper distance between antennas if possible. To reduce the interference between antennas, it is not recommended that an antenna is designed closely next to another one.
- I Carefully design the metallic components (such as the external frame of the metallic shell) in and near the antenna area with considering the effects on the antenna performance (such as whether the frequency offset of the antenna occurs and whether the antenna pattern is deformed).

4.5 Offline Mode

The offline mode is a state that the module RF is off, it can be enabled by the following methods:

- I Through hardware: The W_DISABLE pin can be used to control the RF circuit. When the pin is driven to the high level, the RF circuit works; when the pin is driven to the low level, the RF circuit does not work.
- I Through software: The AT command of AT^RFSWITCH can be used to control and query the status of the RF circuit.

For the offline mode, the following customizations can be realized on the firmware:

1. The RF circuit works each time the module is powered on.
2. The RF circuit does not work each time the module is powered on.
3. When the module is powered on for the first time, the RF circuit works, and then the module can remember the users' operations.
4. When the module is powered on for the first time, the RF circuit does not work, and then the module can remember the users' operations.

All the preceding customized states are set before the module is delivered and cannot be changed by the end users.

5 Software and Tools

Huawei can provide the firmware, PC driver, dashboard, and software. The firmware runs on the module; the PC driver and dashboard run on the PC and communicate with the firmware to realize all module functions. Huawei can also provide the software for upgrading the firmware and debugging the problems.

5.1 Firmware

The firmware is software on the module. It accepts commands and data from the host through USB. The host can send AT commands to enable the firmware to connect, disconnect, or query.

5.1.1 Version Descriptions

In the version number, the front digits are the firmware version that can differ which version is newer. The upper bits (except the last two bits) has boarder meaning in the version name. If the customer has special order to our common version, the order will be implemented in special version. The version is named by last two bits, but the front bits are still the common version.

XX.XXX.XX.XX.XX



Firmware version

Customization version

5.2 Drivers

A driver is a program running on the host system, which allows the host system to interact with the Huawei wireless module. The driver communicates with the firmware of the module by using the USB protocol.

The USB manufacturer ID for all Huawei USB devices is **0x12D1**.

The USB product ID for the EM770W device is **0x1404**. There are three USB interfaces in the USB product ID.

5.2.1 Windows Drivers

Huawei provides windows drivers to support Windows 2000/Windows XP/Windows Vista/Windows 7.

Huawei provides the following two ways to install the drivers:

- 1 The drivers are packed in the dashboard, and they will be installed during the dashboard installation.
- 1 The drivers are provided as an installer, which can be directly installed under Windows 2000/Windows XP/Windows Vista/Windows 7.

After the drivers are installed, when the EM770W is connected to the USB bus, it will be detected as a USB device and start enumerating. During this process, multiple drivers are loaded. These drivers expose a number of virtual COM ports.

In Windows OSs, you can check the enumerated devices and their configuration in the device manager. If you switch to **View by connection**, the device manager displays the main USB device and interfaces, as shown in Figure 5-1, this figure is just a sample, and different products maybe add or remove some ports.

Figure 5-1 HUAWEI USB device and interfaces

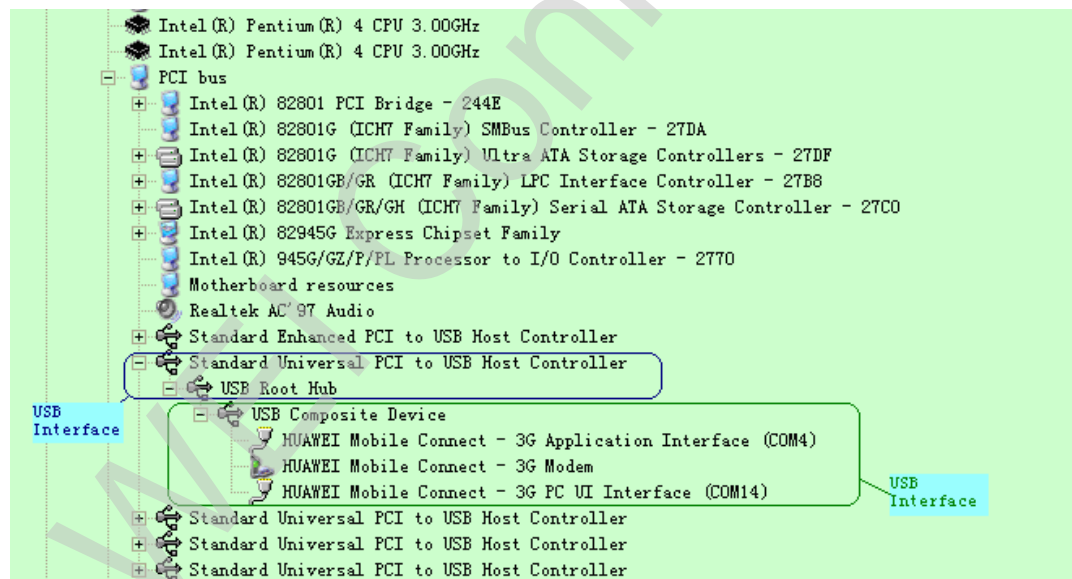

The following interfaces and ports are supported by EM770W:

- 1 HUAWEI Mobile Connect – 3G Modem: used to set up a data connection.
- 1 HUAWEI Mobile Connect – 3G Application Interface: used to write and read diagnostics data.
- 1 HUAWEI Mobile Connect – 3G PC UI Interface: used to send AT commands and read their responses.
- 1 HUAWEI Mobile Connect – 3G GPS Interface: used to support the output of NMEA-0183 sentences. The port appears only when GPS feature is supported.
- 1 HUAWEI Mobile Connect – Control Interface: used to control and configure GPS. The port appears only when GPS feature is supported.

5.2.2 Linux Drivers

The EM770W can be used in the Linux OS that the kernel version is 2.6.18 or later. If the kernel is a standard one, it means that the kernel is not customized and the driver is already packed in the kernel; if the kernel is customized and the driver has been discarded, Huawei will provide the Linux driver for customers to merge the driver into the kernel again.

5.3 Dashboard

5.3.1 Windows Dashboard

Huawei can provide the dashboard to manage the connection and other functions under Windows 2000/Windows XP/Windows Vista/Windows 7.

Figure 5-2 shows the screenshot of Huawei common dashboard.

Figure 5-2 Screenshot of Huawei common dashboard

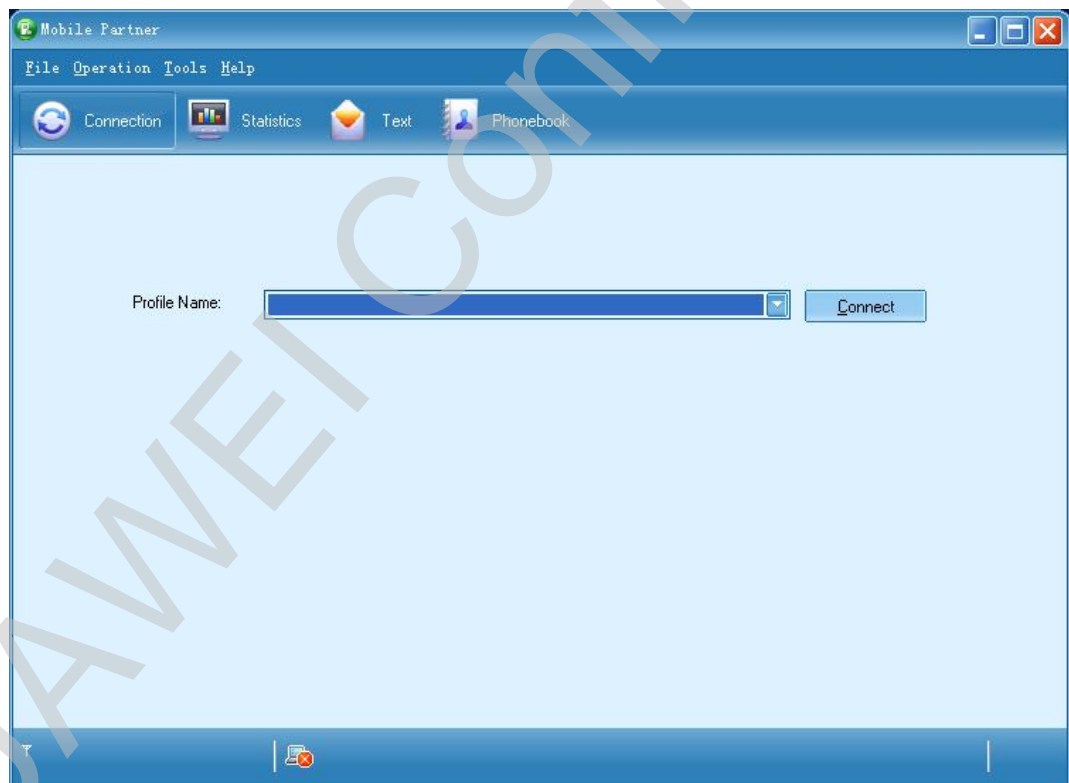

Table 5-1 lists the dashboard specifications.

Table 5-1 Windows dashboard specifications

Item	Description
SMS	Writing/Sending/Receiving

Item	Description
	<p>Sending/Receiving extra-long messages</p> <p>Group sending</p> <p>Storage: The messages are saved in the hard disk of the PC.</p> <p>Sorting</p> <p>Importing: You can import messages from the SIM/USIM card to a PC.</p> <p>New message prompt (visual prompt/audio prompt)</p>
Flow display and statistics (data services)	<p>Current connection:</p> <ul style="list-style-type: none"> ▫ Duration ▫ Send/Receive flow ▫ Send/Receive rate <p>Traffic statistics: You can view the traffic information of the day, the month, or the year.</p>
Phonebook	<p>Capacity: It depends on the SIM/USIM card capacity or the hard disk space.</p> <p>Messages can be sent through the phonebook.</p> <p>Importing/Exporting: Import or export contacts between the SIM/USIM card and a PC or a file of supported formats.</p>
Network connection setup	<ul style="list-style-type: none"> ▫ APN management: create, delete, edit, import, and export. ▫ Set up the network connection.
Network connection settings	<ul style="list-style-type: none"> ▫ Automatic network selection and registration ▫ Manual network selection and registration
Network status display	Signal status, operator name, system mode, and so on.
network connection types	<p>Selection of network connection types, for example:</p> <ul style="list-style-type: none"> ▫ 3G preferred ▫ GPRS preferred
PIN management	Activating or deactivating PIN, PIN lock, changing PIN, and unblocking PIN by using the PUK
System requirement	<ul style="list-style-type: none"> ▫ Windows 2000 SP4, Windows XP SP2, Windows Vista, Windows 7. ▫ The hardware system on the PC should meet or exceed the recommended system requirements for the installed version of OS. ▫ Display resolution: 800 × 600 or above

Item	Description
Notes: CPU = central processing unit PIN = personal identification number PUK = PIN unblocking key	

5.3.2 Linux Dashboard

The Linux dashboard can be developed separately according to the customization requirements of customers.

5.4 GPS

5.4.1 Introduction

The EM770W can support GPS standalone and assisted GPS (A-GPS).

1. Air Interfaces Supported

Operates in all major air interfaces (GPRS/GSM/EDGE/UMTS/HSPA)

2. Standards Compatibility & Architecture Support

- I Compatible with Qualcomm's positioning software for location servers as well as other servers.
- I Compatible with 3GPP standards and OMA SUPL1.0.
- I Supports both "Control Plane" positioning(protocols used in the signaling plane) and "User Plane" positioning(Protocols used in a data call).

5.4.2 Functionality

1. GPS Four Operation Modes

- I Mobile-Assisted Mode (high availability and network app-friendly)
- I Mobile-Based Mode (GPS-only at this time, low latency, handset application-friendly)
- I Hybrid Mobile-Assisted
- I Standalone Mode (no assistance data required, GPS-only, off-network-capable)

2. GPS Ports

Huawei module has two ports for GPS functionality, one is GPS interface which is used for GPS NMEA data reporting, and the other one is Control interface which is used for GPS parameters configuring. Please refer to Figure 5-3 for detailed information.

Figure 5-3 GPS COM ports (3G GPS Interface and Control Interface)

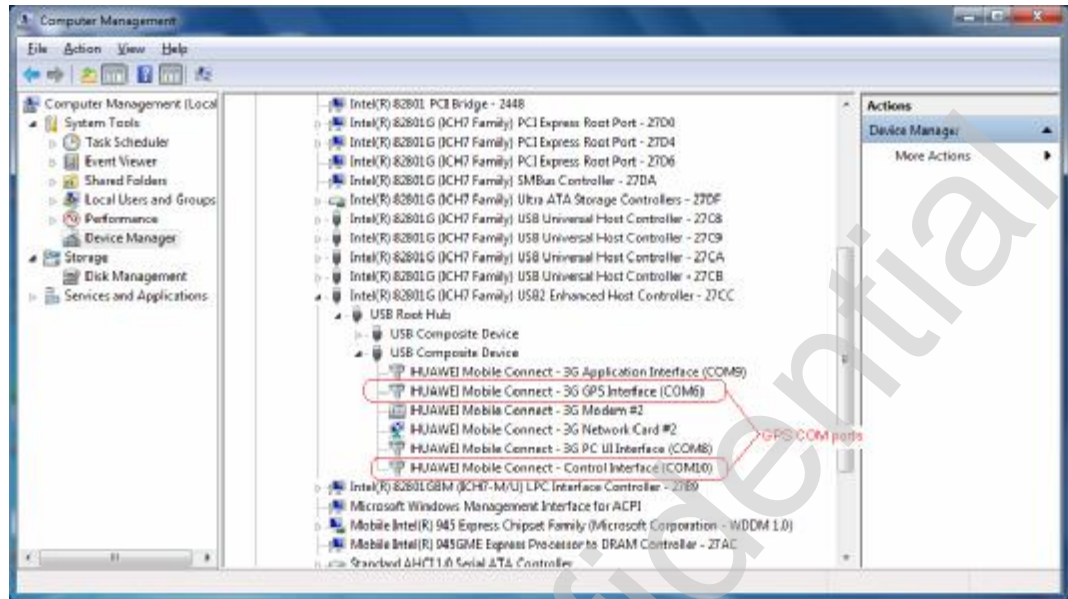

3. GPS Output

NMEA sentences are supported over USB configurable via 3G GPS Interface port, including GGA, GSV, GSA, VTG and RMC in accord with NMEA0183 version3.1.

NV items can control which NMEA sentences are generated.

The output of NMEA sentences is automatic and the update rate is 1 second by default.

4. GPS Antenna

GPS antenna is physically shared with the receive diversity antenna. Now only passive GPS antenna is supported.

5. GPS AT Commands

The AT commands are provided to set GPS parameters and start or stop GPS. A dedicated document which describes the AT commands for the module's GPS functionality is available. See the *Huawei UMTS Embedded Module AGPS AT Command Interface Specification* for details.

6. Simultaneous GPS operation with other UE operations

Standalone GPS can work simultaneously with other UE operation.

SUPL and other PS data service can share the same PDP session with the same APN, and also can be supported on the different PDP session with the different APN.

5.4.3 Performance

- I Cold start sensitivity is -145dBm , Tracking sensitivity is -156dBm
- I Accuracy 5-15 meters in assisted modes, CEP95%, open sky
- I Accuracy 10~50 meters in Standalone mode, CEP95%, open sky

- I TTFF processing time 2-10 seconds in assisted modes, open sky
- I TTFF processing time 1/32/65 seconds in Standalone mode(super hot/warm/cold), open sky

It is strongly recommended inserting SIM card while using GPS functionality, because it could improve GPS accuracy.

5.4.4 GPS Applet

To operate the GPS function, Huawei has a GPS Applet which provides a friendly UI for customer. Figure 5-4 shows GPS Applet installation file.

Figure 5-4 GPS Applet installation file

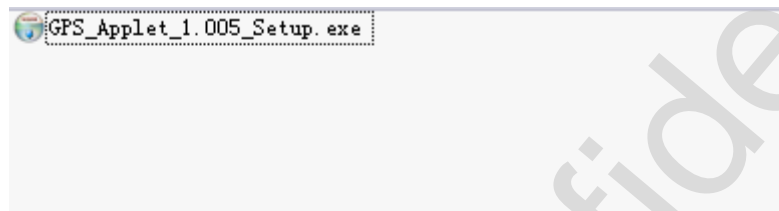

Please double click the installation file to install it, shown in Figure 5-5.

Figure 5-5 GPS Applet Installation Step 1



Click **Next** to continue the installation step. Refer to Figure 5-6.

Figure 5-6 GPS Applet Installation Step 2



Click **Install** to continue the installation step. Refer to Figure 5-7.

Figure 5-7 GPS Applet Installation Step 3



Click **Finish** to finish the installation, and GPS applet should run after clicking the button. The installed GPS applet looks like Figure 5-8. There are buttons for starting GPS, stopping GPS, setting GPS parameters, setting GPS applet running automatically while OS starting up, providing basic information of GPS (such as GPS port number which reports NMEA data, longitude information, latitude information, satellites numbers information which Huawei module has tracked, current time information), providing a quick launch setting for the GPS navigation application.

Figure 5-8 GPS Applet UI

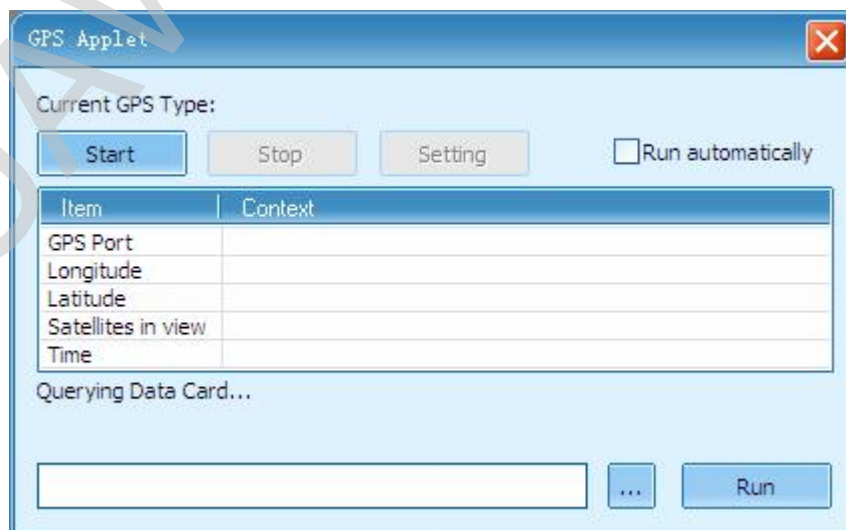
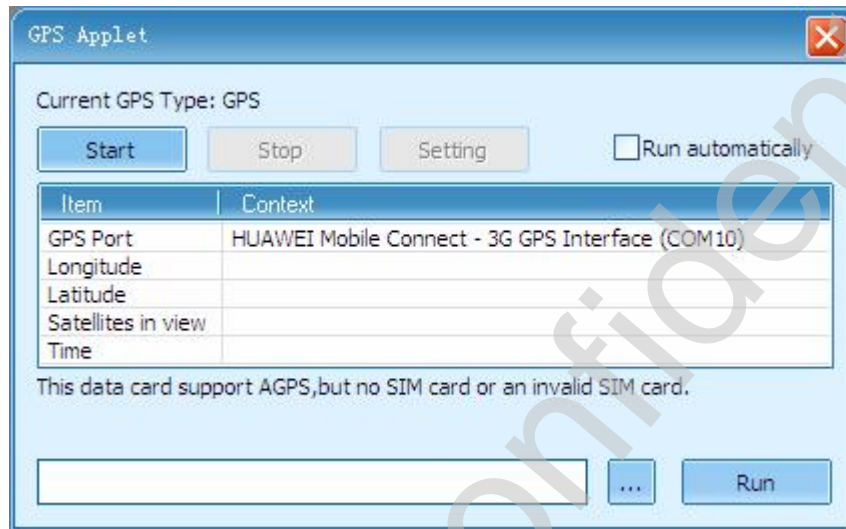

Figure 5-8 shows that no Huawei module is connected. Figure 5-9 shows that Huawei module has been connected, and the GPS port shows **HUAWEI Mobile Connect - 3G GPS Interface (COM 10)**, it means the GPS NMEA data reporting port is COM 10, which can be used by the navigation application to receive GPS position data.

Figure 5-9 GPS Applet UI while Huawei Module connected (no SIM or invalid SIM)



Once Huawei module is removed by user, GPS Applet will show the following message in Figure 5-10.

Figure 5-10 GPS Applet UI While Removing Huawei Module

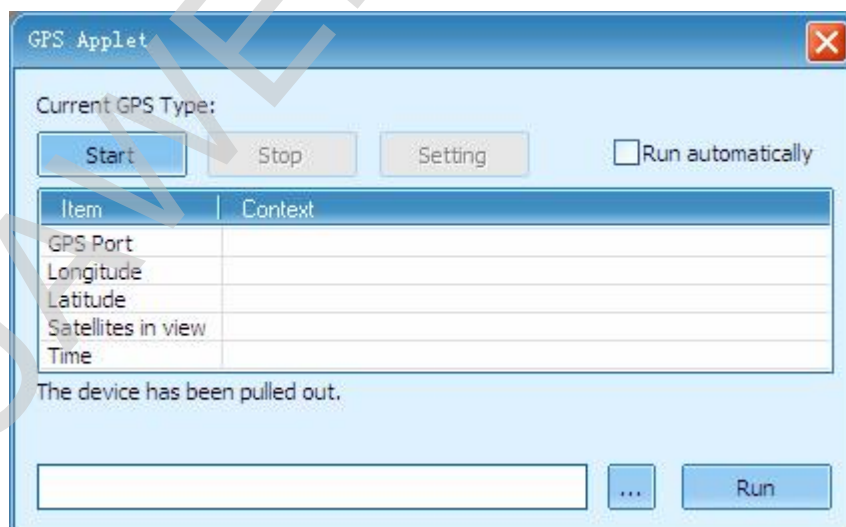

If AGPS function is enabled and the SIM card is ready, the "Setting" button will be activated, shown in Figure 5-11.

Figure 5-11 GPS Applet UI While Inserting valid SIM and Huawei Module (supports AGPS)

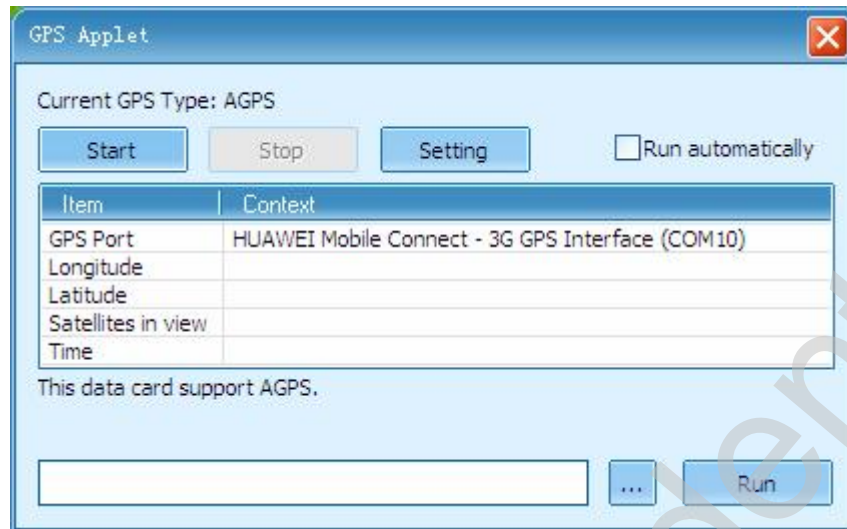

GPS Applet's setting UI for some GPS parameters setting. Please refer to Figure 5-12.

Figure 5-12 GPS Applet Setting UI

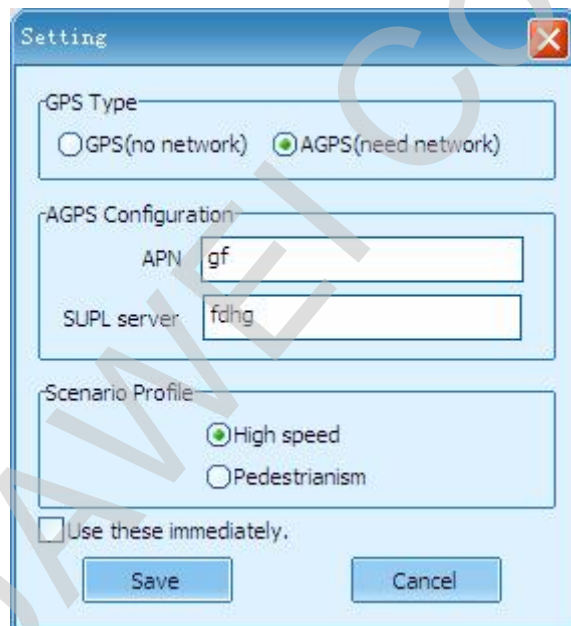

Figure 5-13 shows how to create a quick launch for a GPS navigation application.

Figure 5-13 GPS Applet Creating A GPS Navigation Application UI

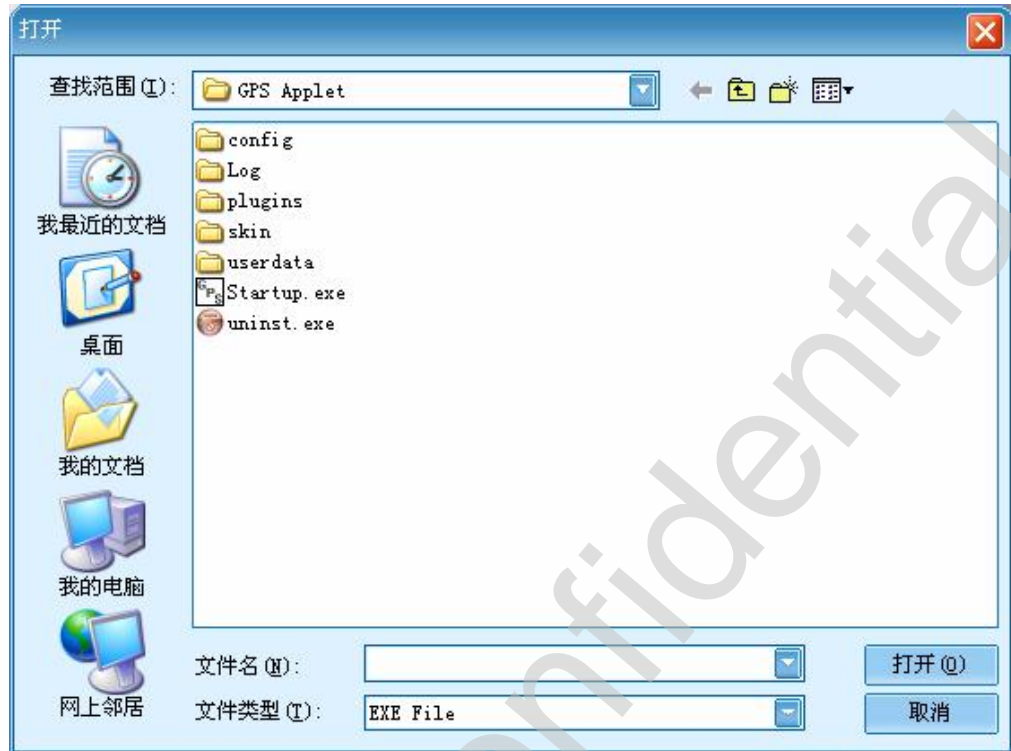
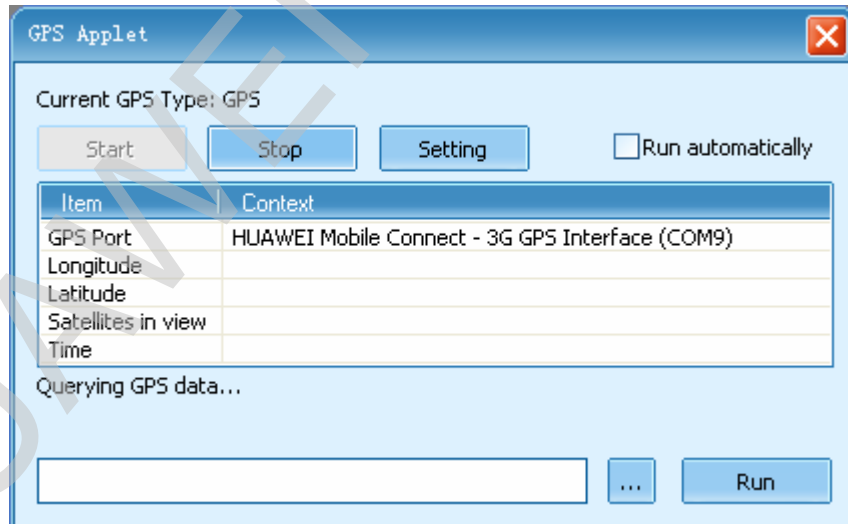

Figure 5-14 shows how to start GPS functionality.

Figure 5-14 GPS Applet UI While Starting GPS Functionality 1



After starting GPS functionality, Figure 5-15 shows the GPS applet UI while no GPS NMEA data reporting.

Figure 5-15 GPS Applet UI While Starting GPS Functionality 2

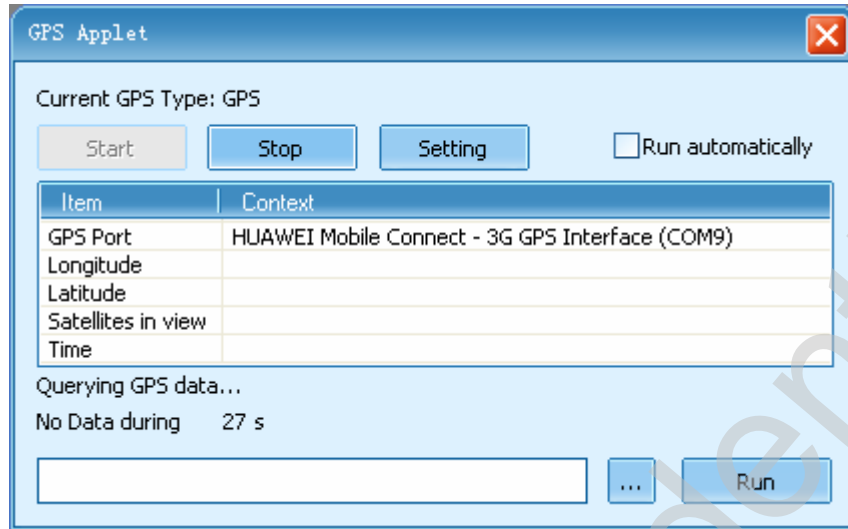

Figure 5-16 shows stopping GPS functionality successfully.

Figure 5-16 GPS Applet UI While Stopping GPS Functionality

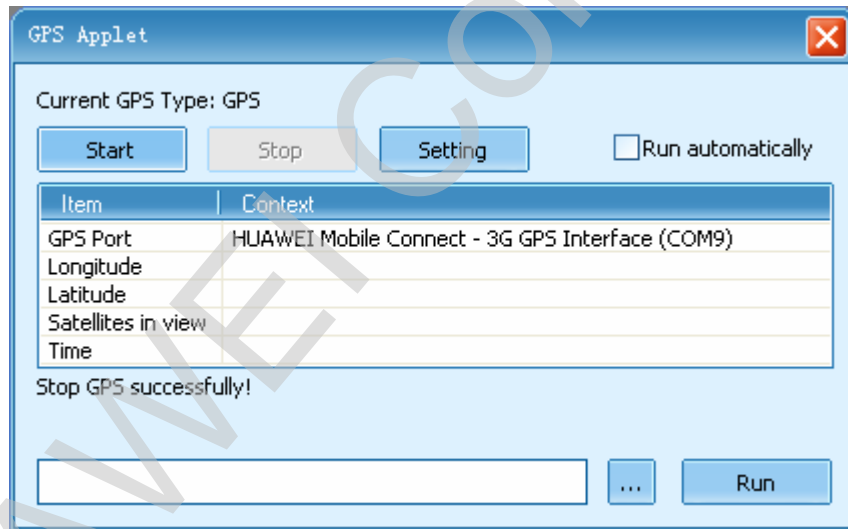
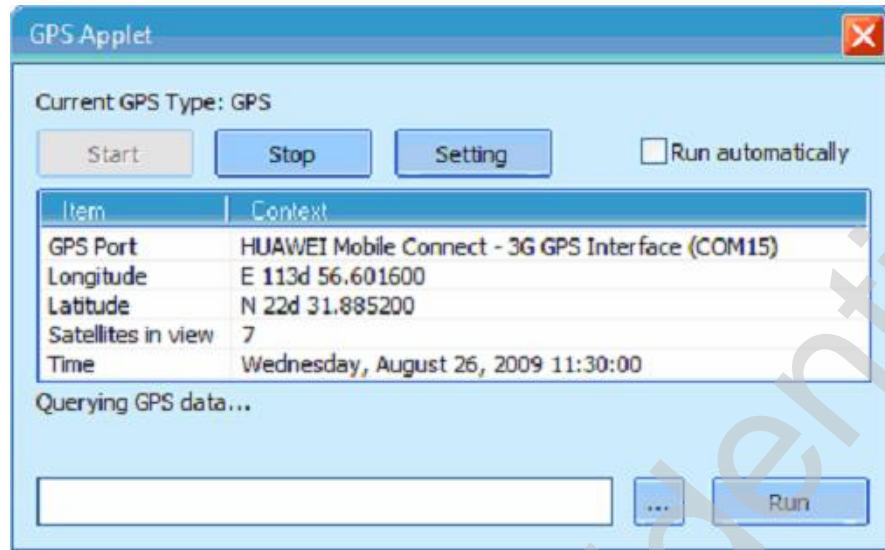

Figure 5-17 shows a successful GPS track.

Figure 5-17 GPS Applet UI While Successful Track



5.5 Tools

5.5.1 Firmware Update Tool

The Windows-based update tool provided by Huawei is used to update the firmware of the EM770W.

The following figures (from Figure 5-18 to Figure 5-24) show the procedure for using the EM730V update tool. The EM770W update procedure is the same as EM730V.

Figure 5-18 EM730V update tool

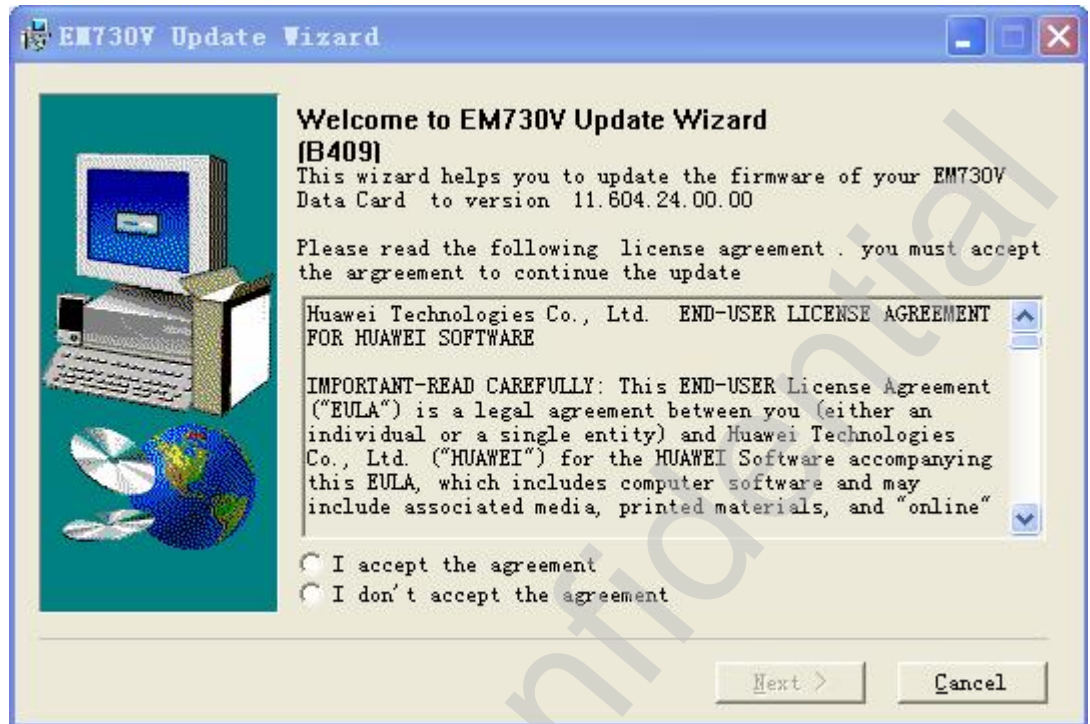

Figure 5-19 Screenshot of the EM730V update tool—Searching the device

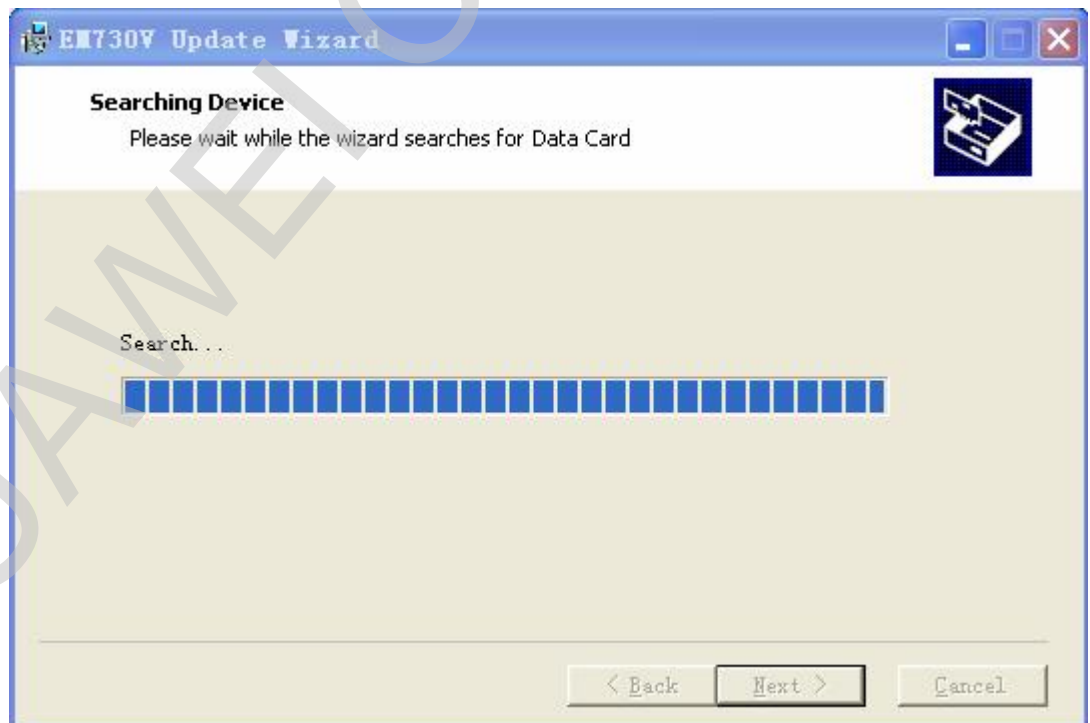

Figure 5-20 Screenshot of the EM730V update tool–Detected devices

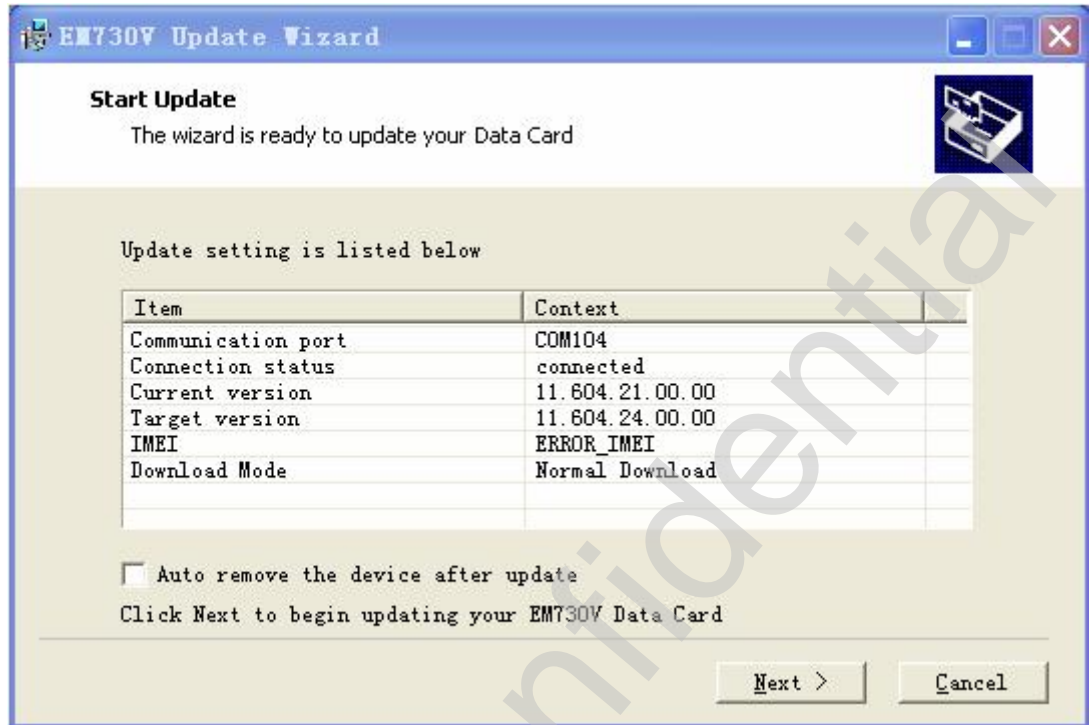

Figure 5-21 Screenshot of the EM730V update tool–Warning



Figure 5-22 Screenshot of the EM730V update tool–Downloading programs

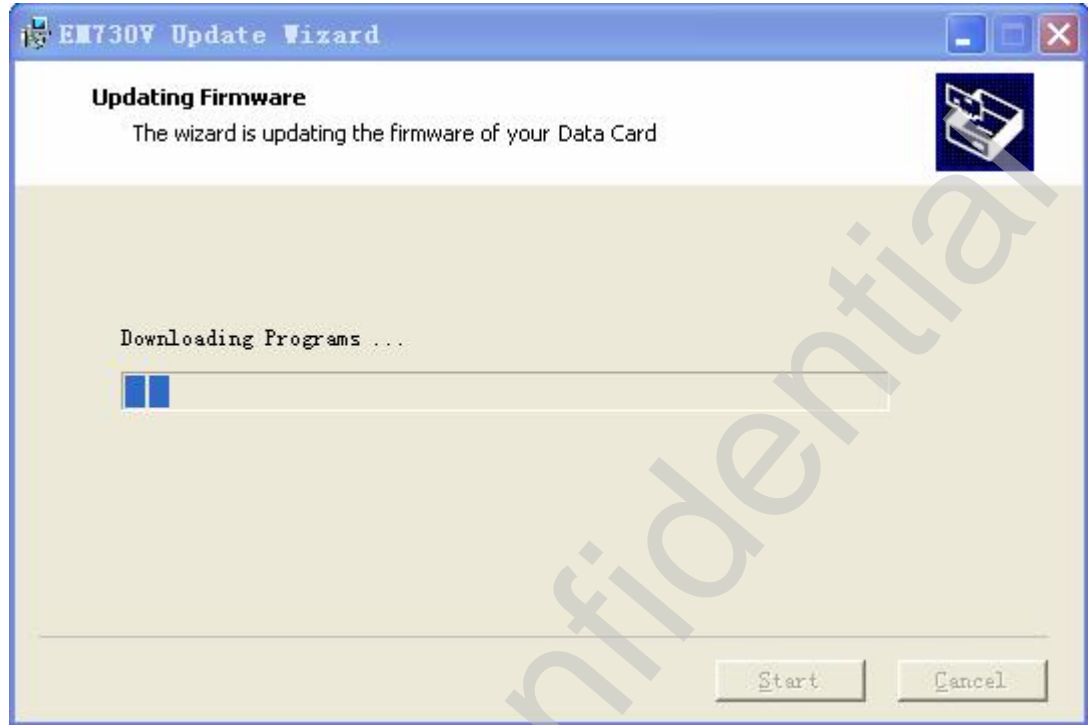

Figure 5-23 Screenshot of the EM730V update tool–Update succeeded



Figure 5-24 Screenshot of the EM730V update tool–To finish the update



5.5.2 Module Label Print Tool–MLT

The Windows-based MLT provided by Huawei can support the label print functions, check board information and check custom settings of the EM770W.

5.5.2.1 MLT Installation

Figure 5-25 and Figure 5-26 show the procedure for installing the MLT.

You can choose installation location, and the default location is circled in red as shown in the following figure.

Figure 5-25 Starting to install the MLT

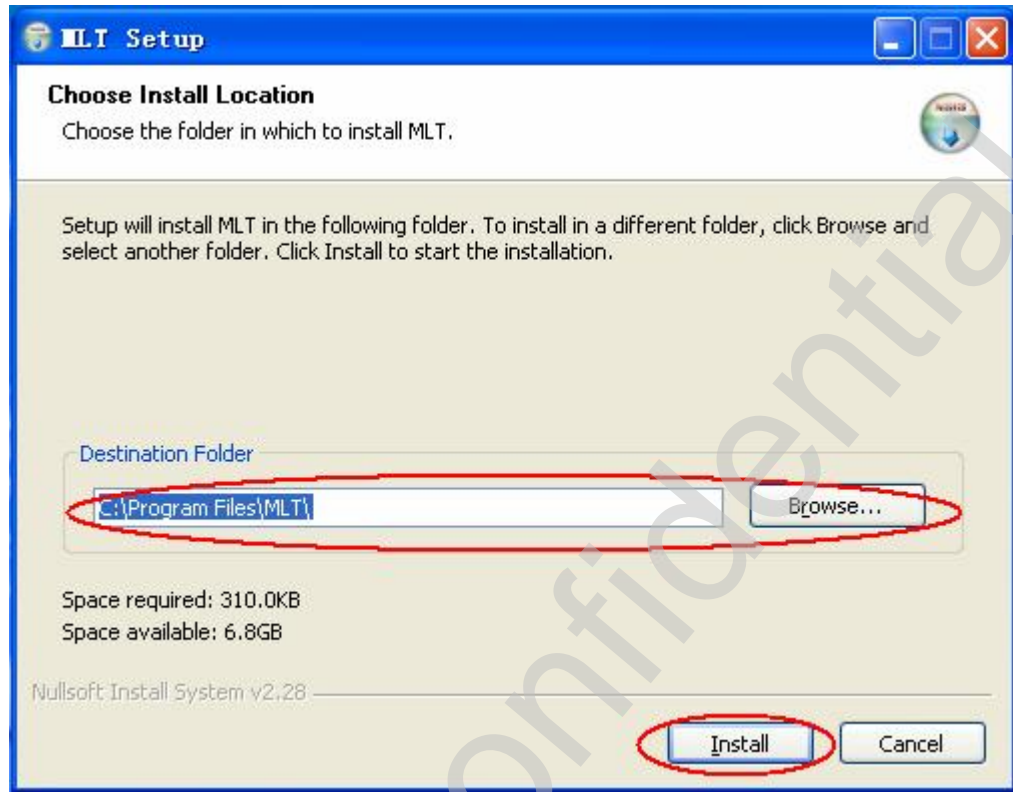
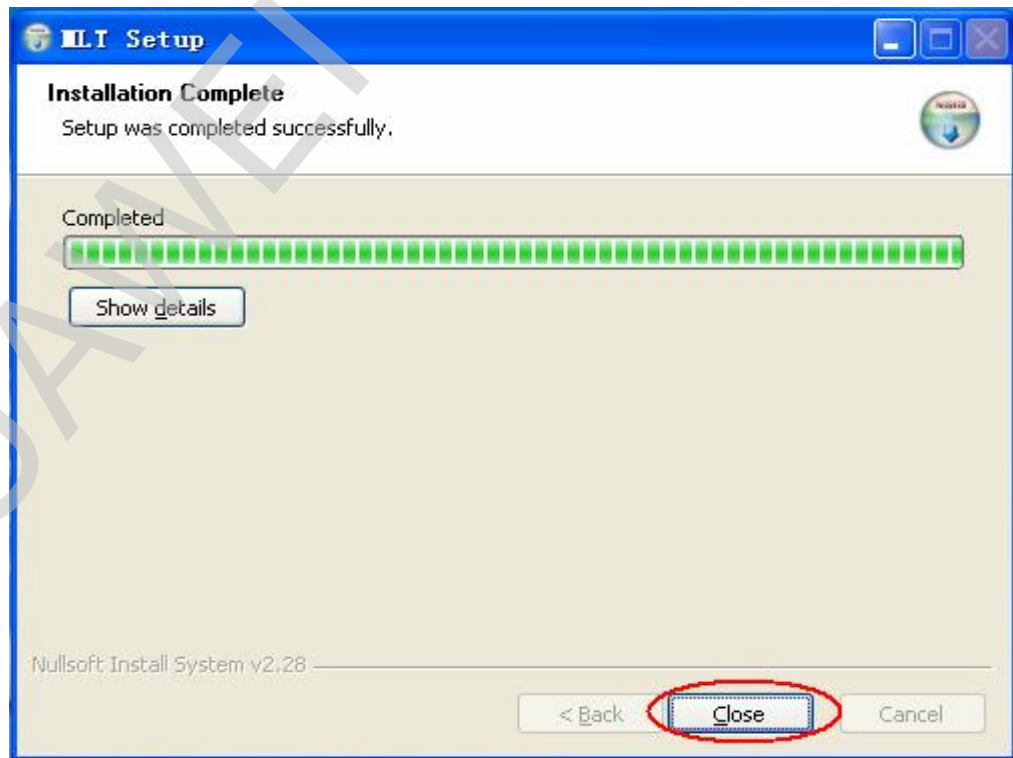

Figure 5-26 Completing the installation of the MLT



5.5.2.2 MLT Functions

The MLT provides the following three functions:

1. Check the information about custom settings.
2. Check the board information, such as the software version, hardware version, and dashboard version.
3. Print the IMEI and SN on the label.

The following figures (from Figure 5-27 to Figure 5-38) show the procedure for using the MLT.

Figure 5-27 Screenshot of the MLT main dialog box

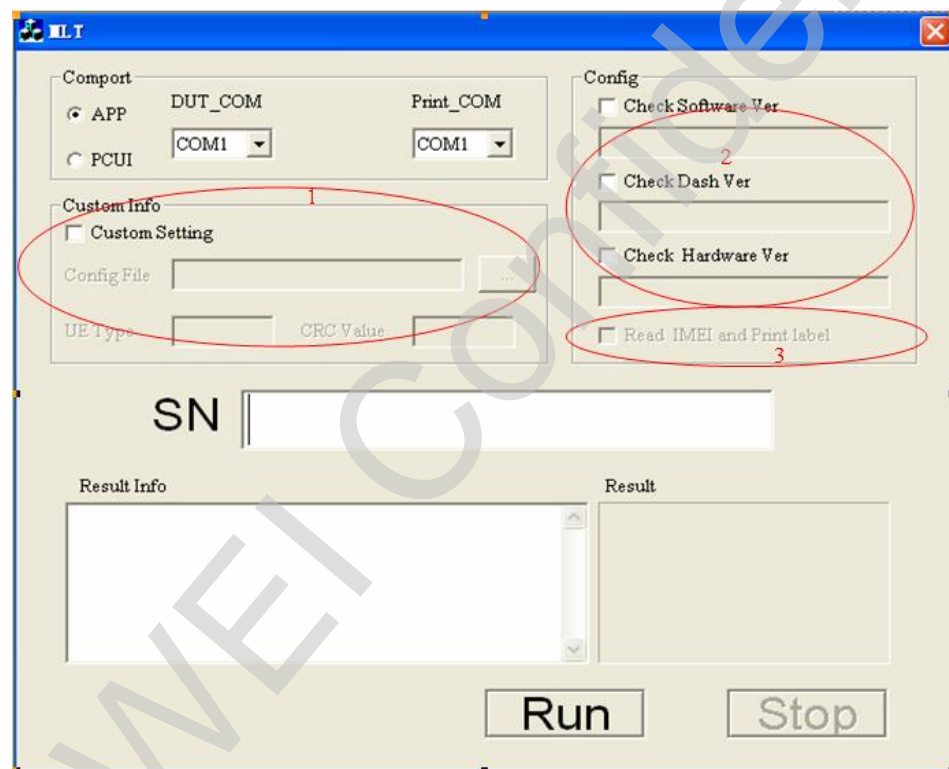

Figure 5-28 Selecting the corresponding port type and port number of the UE

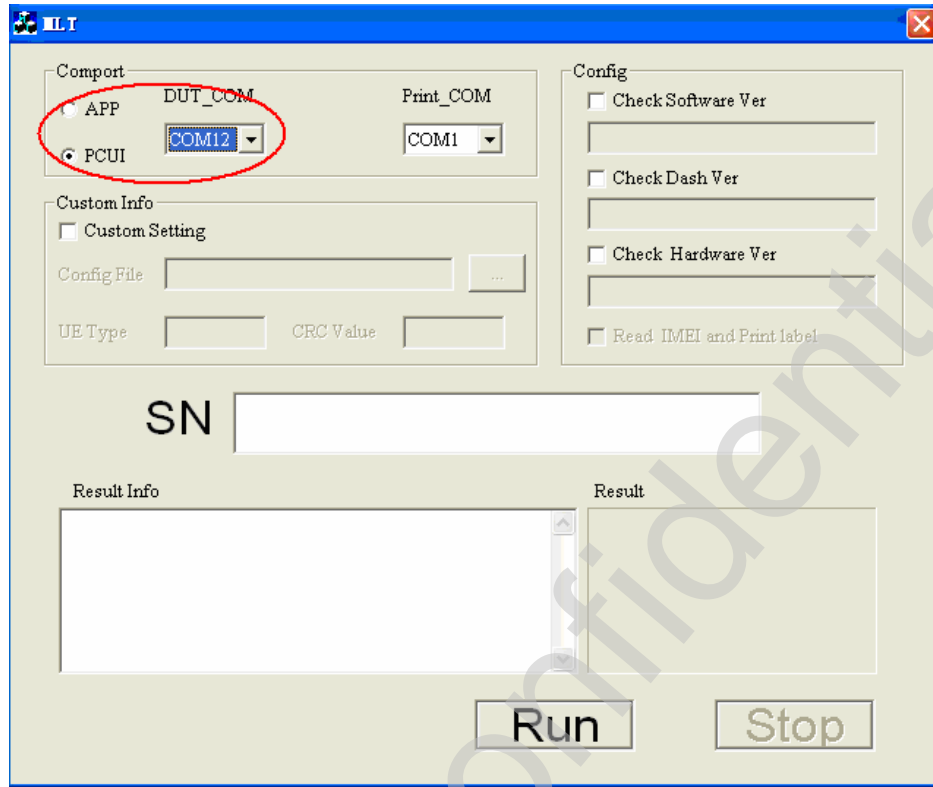

Figure 5-29 Selecting the printer port number

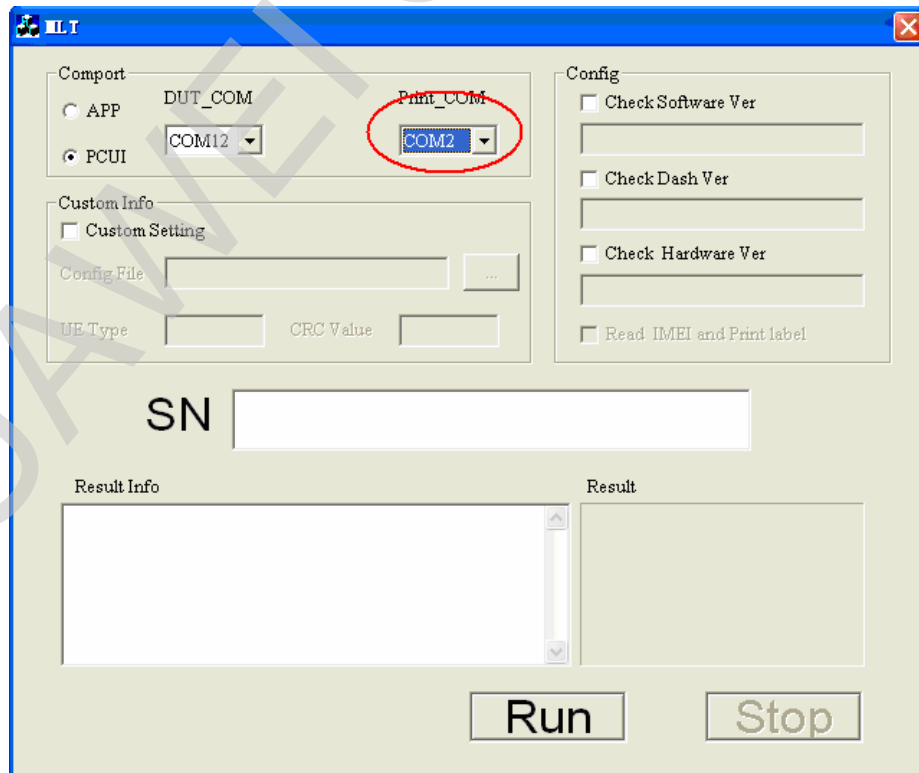

Figure 5-30 Selecting the check boxes in the Config area and enter the corresponding version information

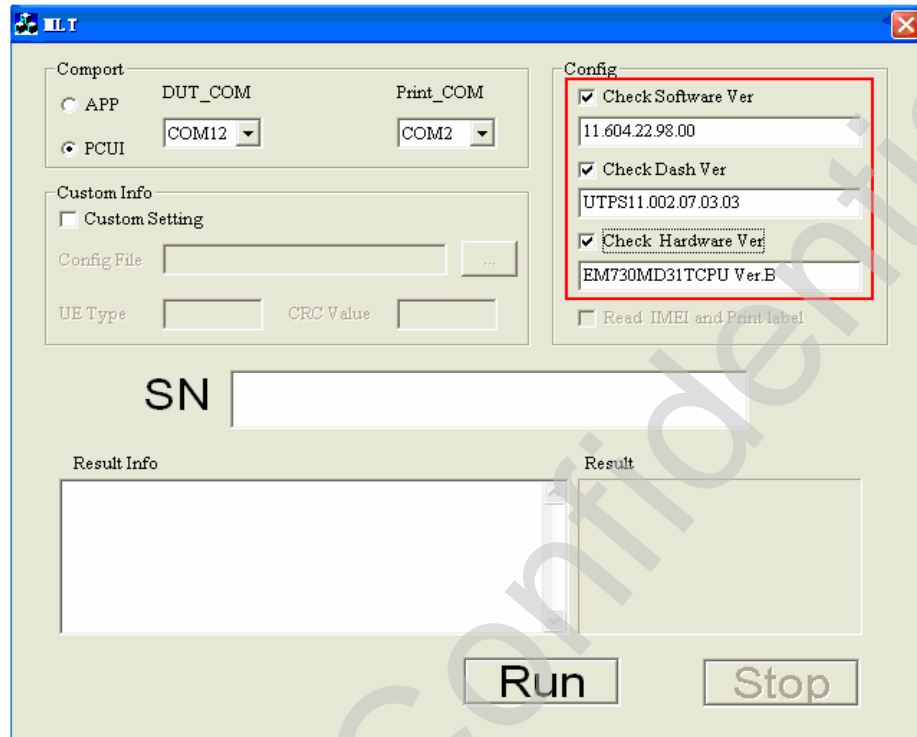

Figure 5-31 Selecting the Custom Setting check box in the Custom Info area

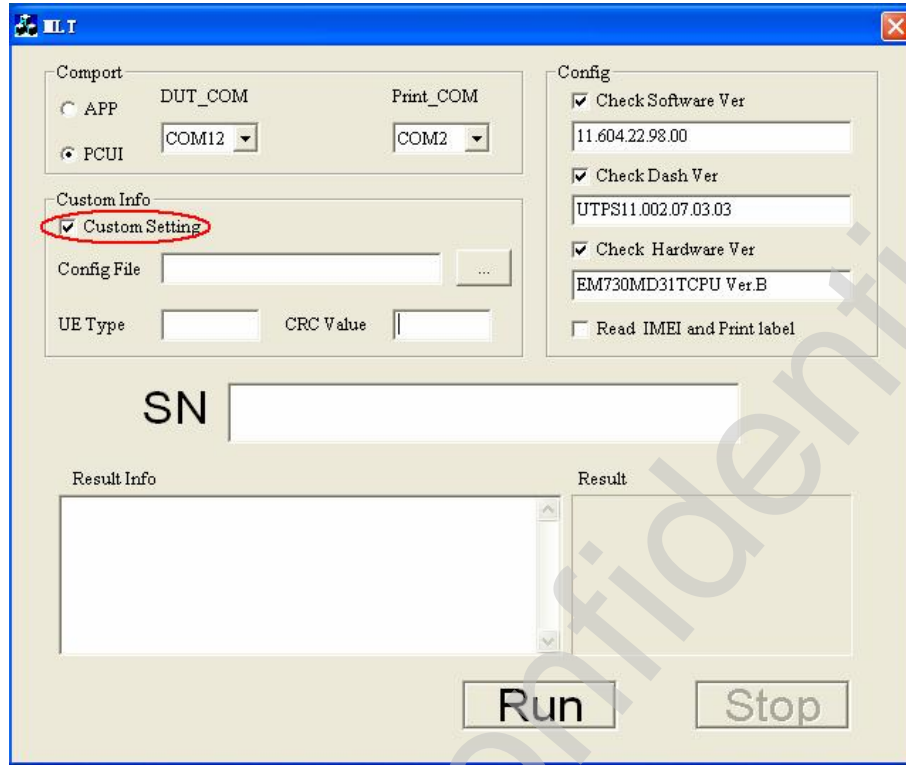

Figure 5-32 Selecting the corresponding configuration file

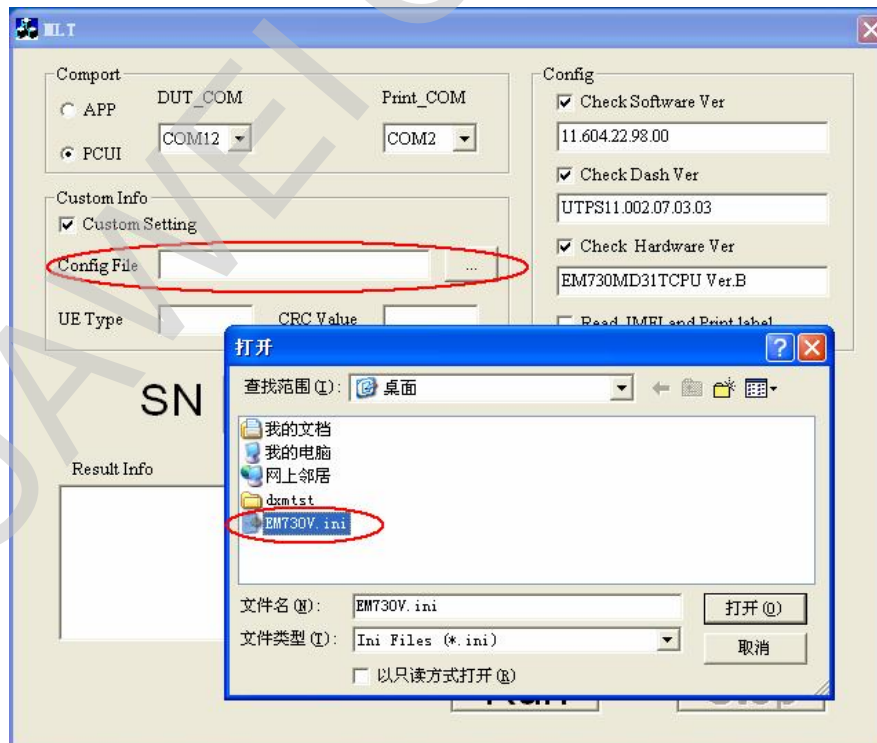

Figure 5-33 Entering the UE type and CRC value that are consistent with the configuration file

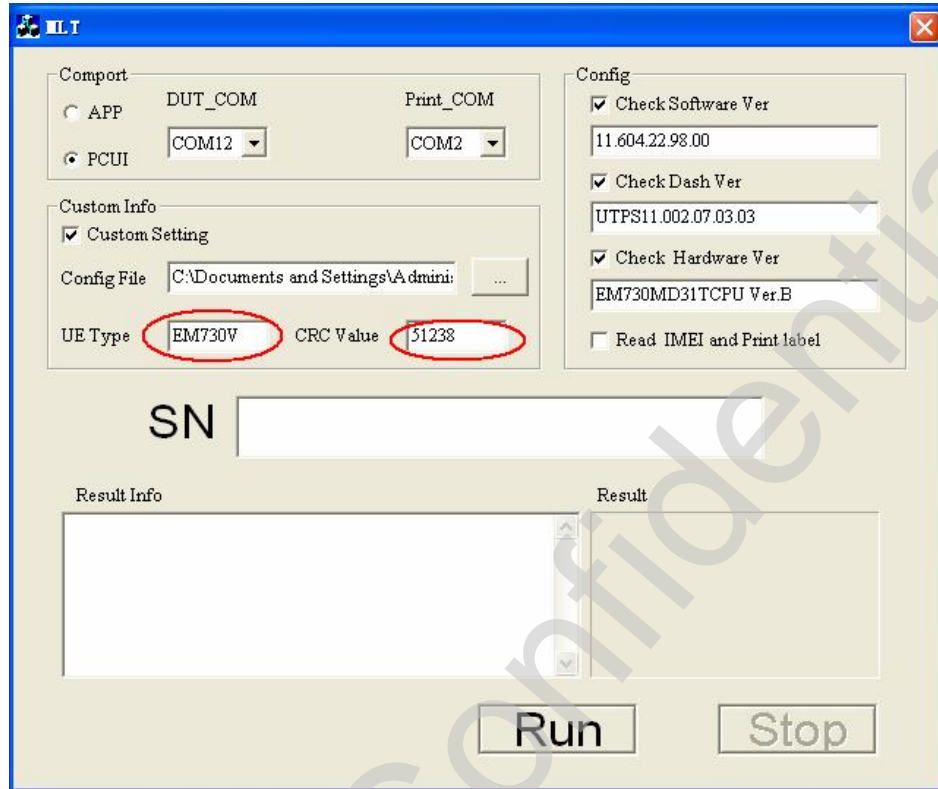
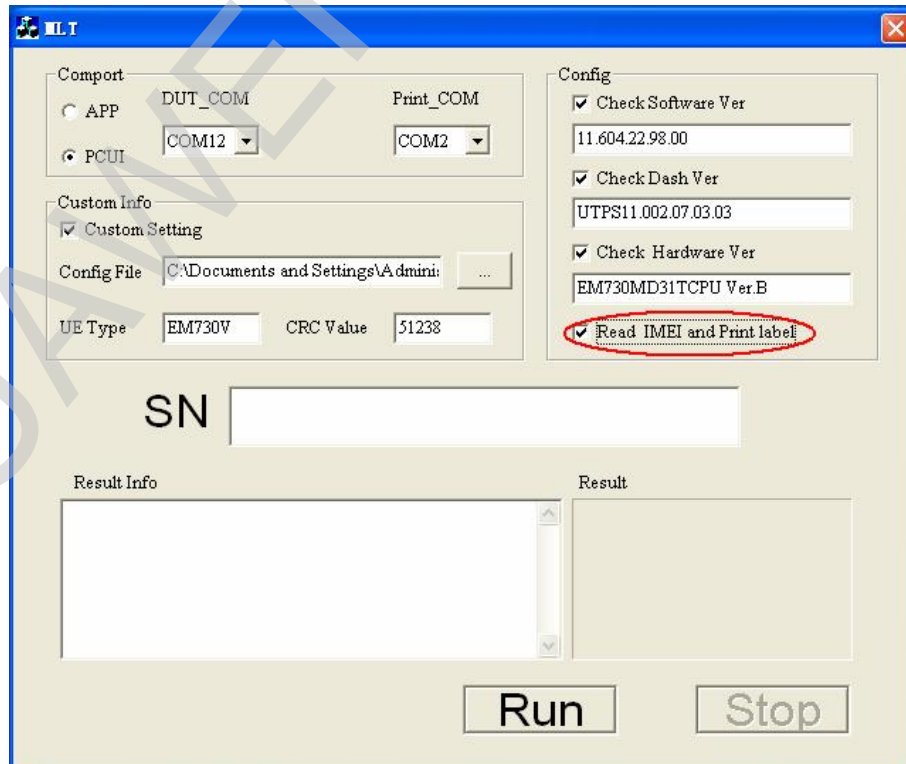

Figure 5-34 Selecting the function of printing the IMEI and SN on the label



As shown in Figure 5-34, if you want to print the IMEI and SN, you must select **Custom Setting** first; otherwise, **Read IMEI and Print label** is invalid. Then, connect a printer to print the label.

Figure 5-35 Scanning or entering the corresponding serial number (that consists of 16 digits)

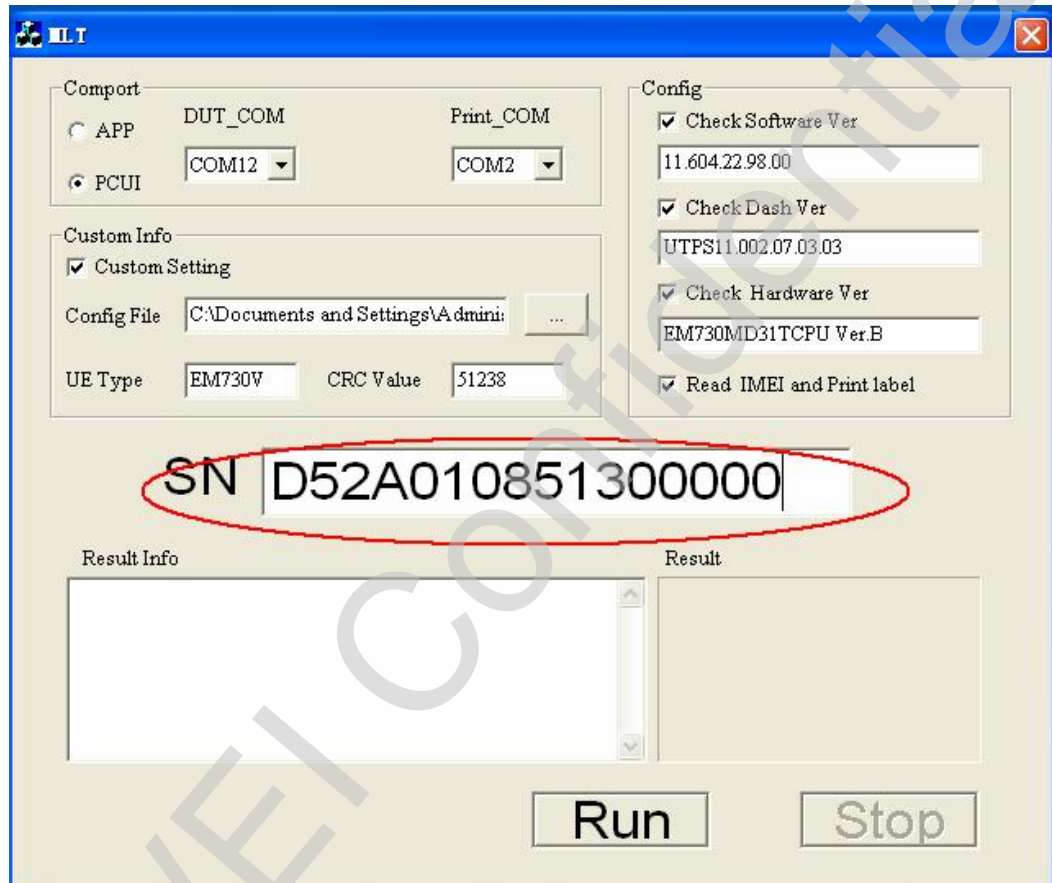

Figure 5-36 Clicking the Run button to start the MLT

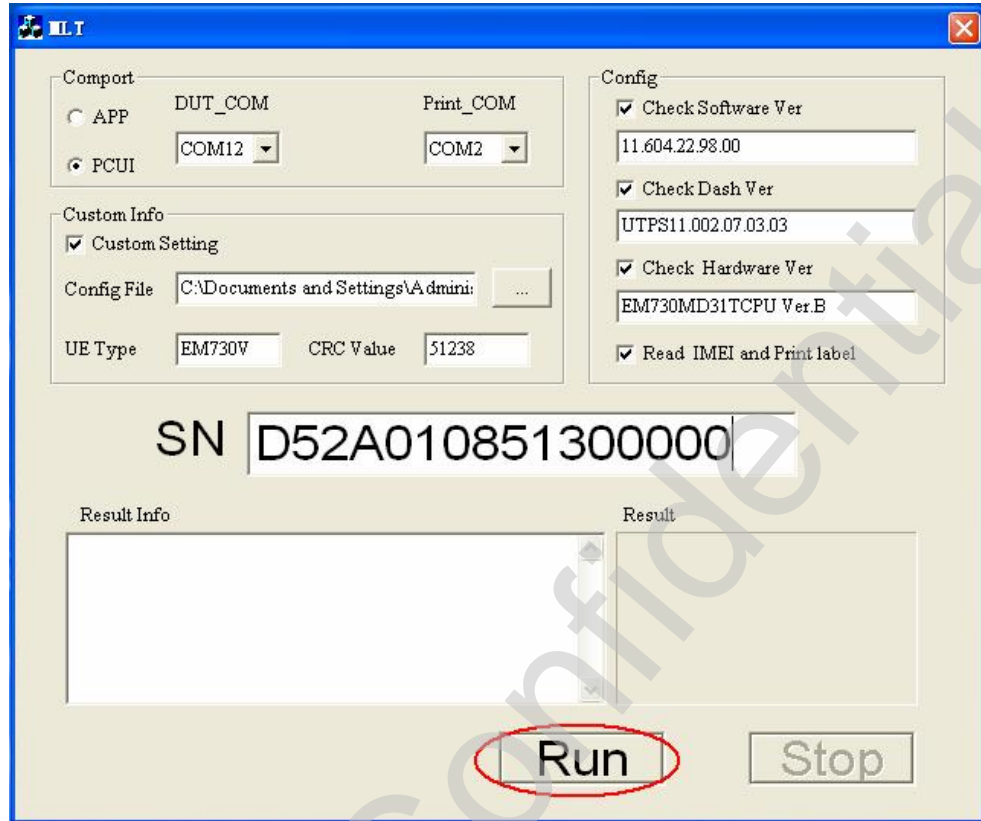

Figure 5-37 Displaying the test result PASS or FAIL

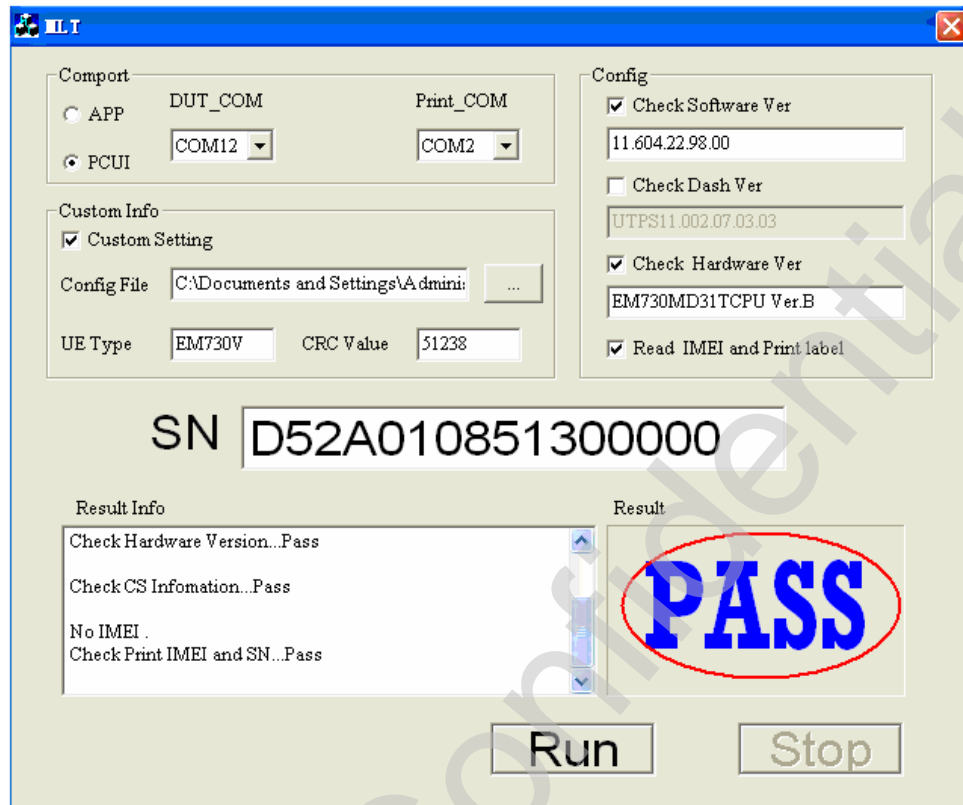
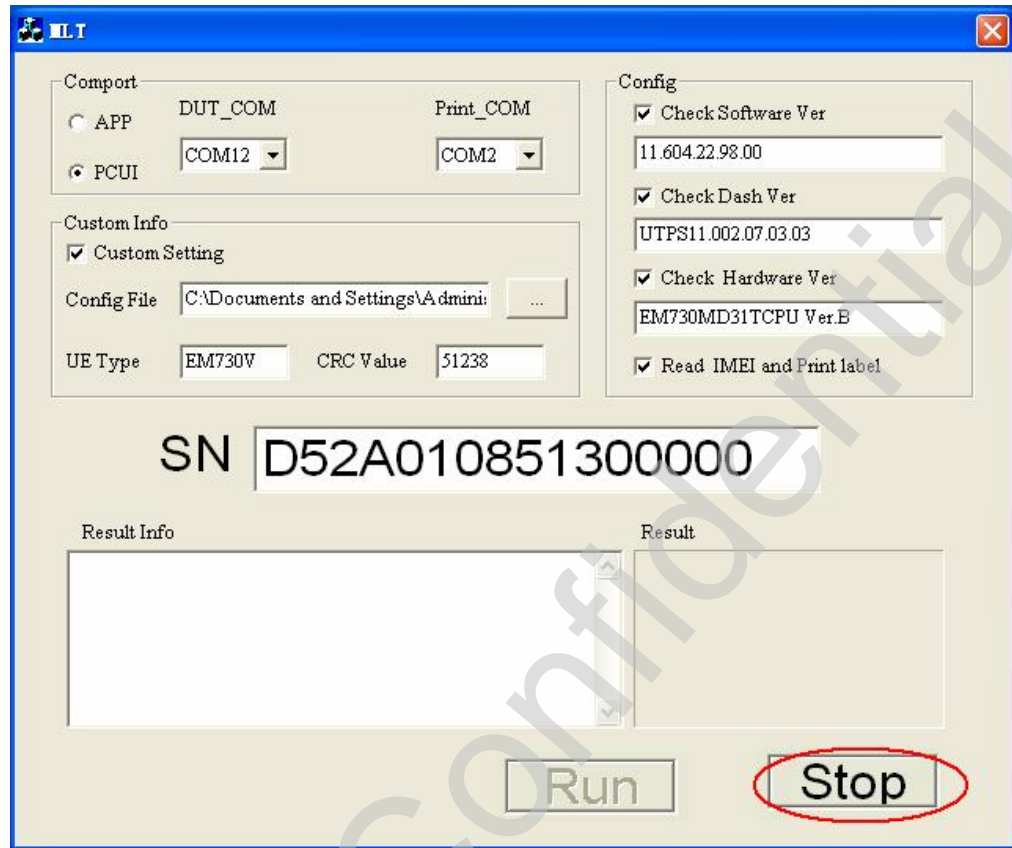

Figure 5-38 Clicking the Stop button to stop the MLT



5.5.3 Engineering Tools

Qualcomm has an extensive debugging and tracing toolset available for their chipsets. Huawei EM770W is compatible with these tools from Qualcomm, such as QXDM, QPST, and QCAT.

5.5.4 Debugging Board

I. Functions and Usage of the Debugging Board

The debugging board developed by Huawei is an auxiliary board that is used to debug the EM770W. When the debugging board is used, you can connect the module to a PC through a USB cable. When the module works normally, the debugging functions can be implemented. The debugging board provides multiple interfaces, such as the USB port, DC power jack, mini PCI-E connector, BTB connector, SIM card socket, RF connectors, PCM audio interface, and serial ports (including a 4-pin serial port and a serial port that all pins are led out). The test points of key signals are led out on the debugging board. In addition, the debugging board is designed with switches or pins of commonly used signals such as the reset signal and the enable signal, for converting the working state of the module.

The debugging board can be used to test the performance of the module. Both the wired connection test (connect the module to the CMU200) and the wireless

connection test (connect the module to the antennas) can be implemented. The signal points can also be tested when you maintain and repair the module.

II. Structure of the Debugging Board

Figure 5-39 Structure of the debugging board

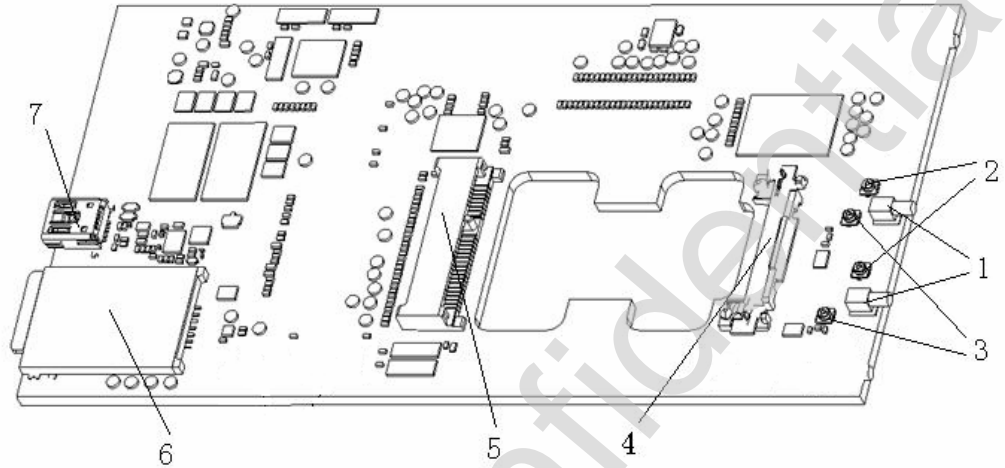

Notes:

1. RF connector: RF switch, bend, female.
2. RF connector: coaxial connector, straight, male.
3. RF connector: RF switch, straight, female.
4. Connector latch: It works with the mini PCI-E connector and is used for fixing the module.
5. Mini PCI-E connector: female, 52-pin, straight.
6. SIM card socket: It is used to holding the inserted SIM card.
7. USB connector and mini USB B-type receptacle: Side-plugging USB connector.

III. Method for Connecting the Debugging Board

1. Diagram of connecting the module to the CMU200

Figure 5-40 Diagram of connecting the module to the CMU200

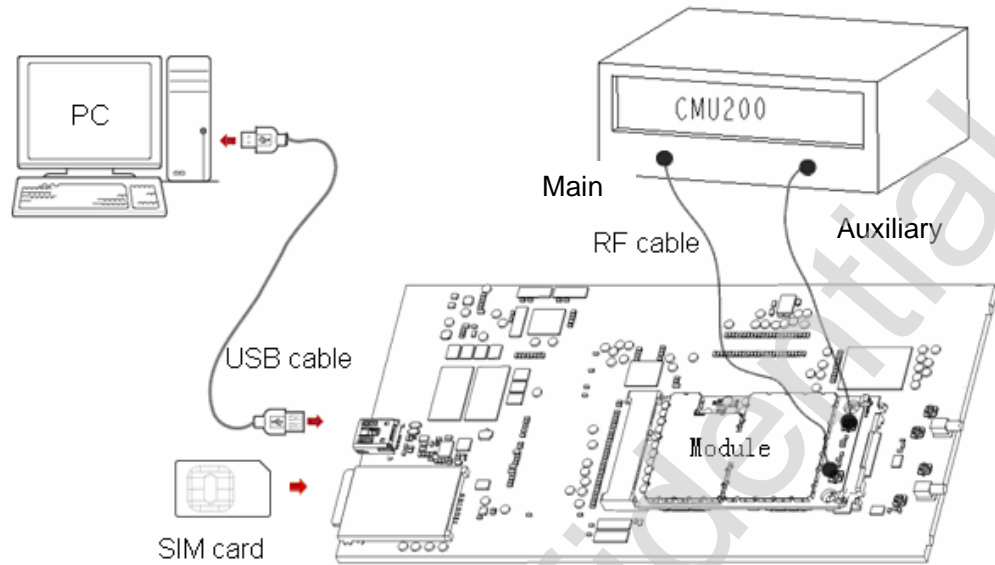

Figure 5-40 shows the connection method that can be used to test the wired connection comprehensively, software and key signal points.

2. Diagram of connecting the module and the antenna

Figure 5-41 Diagram of connecting the module and the antenna

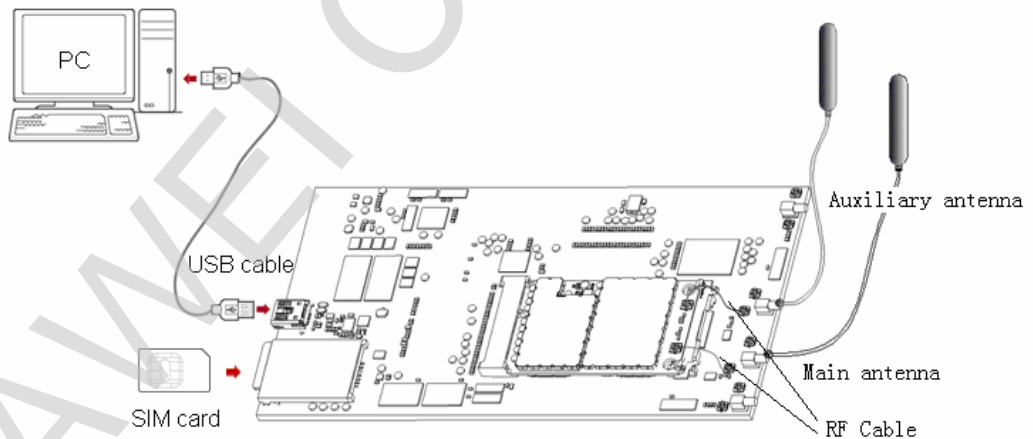

Figure 5-41 shows the wireless connection method that can be used to simulate the actual wireless environment for testing the software and key signal points.

IV. Installation of the Debugging board

- I Connect the devices and set up the test environment according to Figure 5-40 or Figure 5-41. Then properly connect one end of the module to the mini PCI-E connector and fix the other end of the module by well locking the connector latch. Insert the SIM card into the SIM card socket. Then connect the debugging board to the PC through a USB cable. You can connect the USB cable only when the module is properly connected to the mini PCI-E connector and fixed.

- I When performing the wired connection test, connect the CMU200 to the RF interface of the module by using the module-dedicated RF cable. (For the connection method, see Figure 5-40.) The compensation for the line loss of the CMU200 is about 0.7 dBm.
- I When performing the wireless connection test, connect the module to the debugging board by using the RF cable. Then connect the antennas to the RF interface of the module directly. (For the connection method, see Figure 5-41.)

V. Test Method

After the preceding operations, if the LED below the mini PCI-E connector, you can infer that the program is running. Then the following functions can be realized by using the debugging board.

1. Controlling the states and testing the performance in each state

The debugging board is designed with pins. You can control the module state through the pins. The silkscreen printing is used to label the pins on the debugging board.

You can manually control the power supply, dormant, waking up, and RF functions, and the reset state through the following pins:

- I J101: You can manually control the input enable signal (VEN) of the LTC3442 chip. When you connect the jumper header to the right of J101 (VEN is driven to the low level), the power supply is cut off; when you remove the jumper header, no impact is caused to the power output.
- I J202: You can manually control the signal (WAKEUP_N) that the PC uses to wake up the module. When you connect the jumper header to the left of J202 (WAKEUP_N is driven to the low level), the module works; when you connect the jumper header to the right of J202 (driven to high level), the module hibernates.
- I J203: You can manually control the signal (WAKE_NB_N) that the module uses to activate the PC. When you connect the jumper header to the left of J203 (WAKE_NB_N is driven to the low level), the PC can be activated and the main power supplies the power; when you connect the jumper header to the right of J203 (driven to the high level), no impact is caused to the PC.
- I J204: You can manually control the module reset signal (PERST_N). When you connect the jumper header to the right of J204 (PERST_N is driven to the low level), the module is reset; when you remove the jumper header, the module works normally.
- I J205: You can manually control the signal (W_DISABLE_N) for disabling the RF function of the module. When you connect the jumper header to the left of J205 (W_DISABLE_N is driven to the low level), the RF function of the module is disabled and the module enters the offline mode; when you connect the jumper header to the right of J205 (driven to the high level), the RF function of the module is enabled.

You can manually control the PCM voice function of the debugging board through the following pins:

- I J501: You can manually control the signal (MICMUTE) for muting the microphone used for the PCM voice function. When you connect the jumper header to the left of the J501 (MICMUTE is driven to the high level), the microphone is muted.

- I J502: You can manually control the signal (EARMUTE) for muting the earphone used for the PCM voice function. When you connect the jumper header to the left of the J502 (EARMUTE is driven to the high level), the earphone is muted.
- I J503: You can manually control the signal (COMP_SEL) for selecting the working mode of the PCM voice function. When you connect the jumper header to the left of J530 (COMP_SEL is grounded and driven to the low level), the 13-bit linear mode is selected; when you connect the jumper header to the right of J503, the 8-bit compressed mode is selected.
- I J504: You can manually control the reset signal (PCM_RESET) of the PCM voice function. When you connect the jumper header to the bottom of J204 (PCM_RESET is driven to the low level), the PCM function is reset; when you remove the jumper header, the PCM function works normally.

Though controlling the module states manually, you can test the performance and parameter in each state by using the CMU200 or other matching software.

2. Testing the key signals

On the debugging board, the test points of all signification signals are led out for testing. Figure 5-42 shows positions of the test points.

Figure 5-42 Test point position

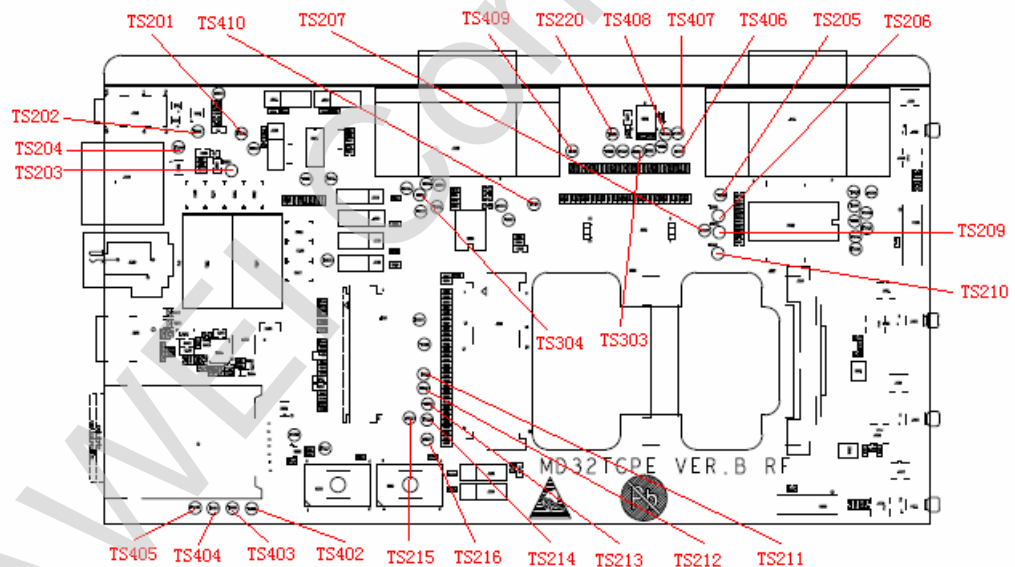

The test points shown in the previous figures are described as follows:

- TS408: WAKE_NB_N (signal that the module uses to activate the PC)
- TS406: WAKEUP_N (signal that the PC uses to wake up the module)
- TS407: W_DISABLE_N (signal for disabling the RF function of the module)
- TS409: PERST_N (module reset signal)
- TS201: MIC_P (input signal of microphone +)
- TS202: MIC_N (input signal of microphone -)

- TS203: EAR_P (input signal of earphone +)
- TS204: EAR_N (input signal of earphone -)
- TS205: UART1_RX (Rx signal of the serial port 1)
- TS206: UART1_TX (Tx signal of the serial port 1)
- TS207: UART1_RI (RI signal of the serial port 1)
- TS209: UART1_CTS (CTS signal of the serial port 1)
- TS210: UART1_RFR (RFR signal of the serial port 1)
- TS211: UART1_DTR (DTR signal of the serial port 1)
- TS212: UART1_DCD (DCD signal of the serial port 1)
- TS303: UART3_RX (Rx signal of the serial port 3)
- TS304: UART3_TX (Tx signal of the serial port 3)
- TS213: PCM_CLK (PCM clock signal)
- TS214: PCM_DOUT (PCM digital output signal)
- TS215: PCM_DIN (PCM digital input signal)
- TS216: PCM_SYNC (PCM synchronization signal)
- TS402: UIM_PWR (power voltage signal of the UIM card)
- TS403: UIM_RESET (UIM card reset signal)
- TS404: UIM_CLK (UIM card clock signal)
- TS405: UIM_DATA (UIM card data signal)
- TS220: LED_WWAN (control signal of displaying the module state)
- TS410: GND

By using the test points on the debugging board, you can test the key signals, resistors, or test points on the module.

VI. Material List

Table 5-2 Material list

Item	Part Number	Quantity	Description
PC	-	1	It is provided by the customer.
CMU200	-	1	It is provided by the customer.
USIM or SIM card	-	1	It is provided by the customer.
Debugging board	03020NTP	1	

Item	Part Number	Quantity	Description
USB cable	02450626	1	It is a 17 cm USB cable used to connect the USB-A connector to Mini USB-B connector.
Antenna	27160038	1	
RF cable 1	02450717	2	It is a 5 cm cable used to connect the debugging board to the module.
RF connector	02450716	1	It is a female-type RF connector used to connect the RF cable to the module.
RF cable 2	02450709	1	It is used to connect the CMU200 to the module.

6 Test and Certification

6.1 Reliability Test for Module

6.1.1 Environmental Reliability Test

Random Vibration

The test conditions are as follows:

- | Temperature: 15°C–35°C
- | Relative humidity: 25%–75%
- | Pressure: 86–106 Pa
- | Frequency: 20–1000 Hz and 1000–2000 Hz
- | Acceleration: 0.04 g²/Hz

Test each of the three axial directions for one hour. For details, see the following figure.

Standards: See section 24 in chapter 1 of MIL-STD 810F Method 514.5 Vibration.

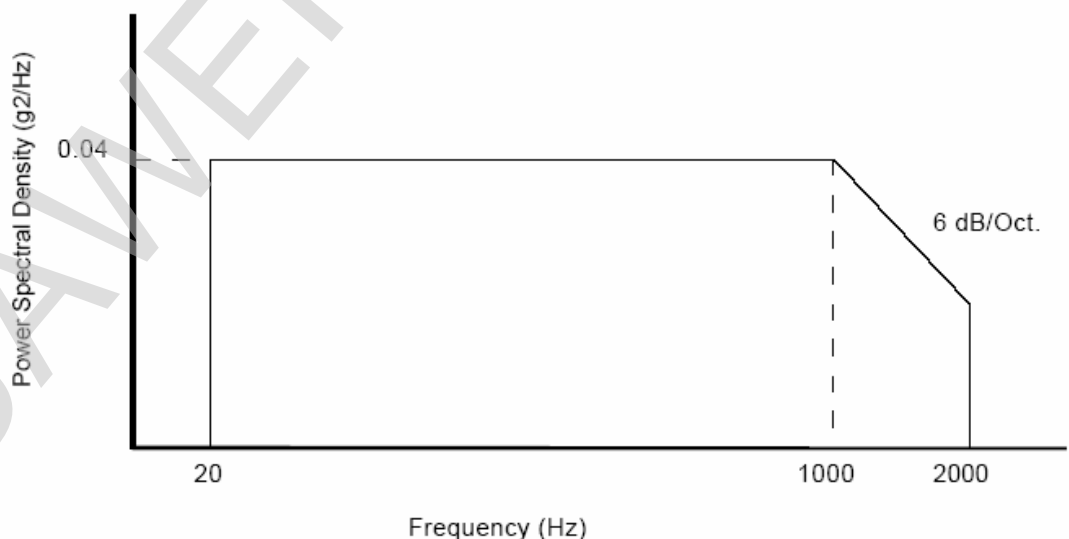

Sine Vibration

The test conditions are as follows:

- | Temperature: 15°C–35°C

- | Relative humidity: 25%–75%
- | Pressure: 86–106 Pa

The vibration test consists of the following two parts:

- | The sample finishes three five-minute sine vibrations (the following table lists the amplitude and the peak-to-peak value). In each test cycle, the frequency increases from 10 Hz to 30 Hz in two and a half minutes and then decreases from 30 Hz to 10 Hz in two and a half minutes.

Category	Amplitude	Peak-to-Peak Value
Consumption	0.0150" (0.38 mm)	0.0300" (0.76 mm)

- | The sample finishes another three five-minute sine vibrations (the following table lists the amplitude and the peak-to-peak value). In each test cycle, the frequency increases from 30 Hz to 60 Hz in two and a half minutes and then decreases from 60 Hz to 30 Hz in two and a half minutes.

Category	Amplitude	Peak-to-Peak Value
Consumption	0.0075" (0.19 mm)	0.0150" (0.38 mm)

Repeat both test parts for 30 minutes in each axial direction.

Standards: See section 3.3.4 in ANSI/TIA-603-C-2004.

Operational Shock

The test conditions are as follows:

- | Temperature: 15°C–35°C
- | Relative humidity: 25%–75%
- | Pressure: 86–106 Pa
- | Peak acceleration: 20 g
- | Shock wave: half-sine wave
- | Pulse width: 11 ms

Test the three axial directions for three cycles.

Standards: See section 3.3.5 in ANSI/TIA-603-C-2004 and section 4.1 in GB/T15844.2.

Salt Spray

The test conditions are as follows:

Spray 5% NaCl solution to the sample for eight consecutive hours at 35°C. Dry the module for 16 hours by airing.

The test procedure is as follows:

1. Expose the most typical surface of the sample in the air according to the minimal test requirements.

2. Pre-treat the sample for two hours at 35°C before the salt spray test.
3. Disconnect the power supply during the test. Emulate the typical configuration of the sample, and then put the sample into the test chamber. Keep the samples independent of each other if two or more samples are tested. To be specific, avoid the influence of deposited salt spray among different samples and prevent corrosive articles from dropping from one sample to another. Lay the electronic connection cables into place or use cables with protected connectors. Install all connectors, covers, and inspection windows into place, though they need not to be tested.
4. Expose the sample to the salt spray for eight consecutive hours.
5. Take the sample out of the test chamber and remove the salt spray from its surface with a cloth. Keep the sample at the ambient temperature for 16 hours, and then remove the foreign materials from its surface with a soft brush.
6. Test the electrical and mechanical performance of the sample.

The system test result must meet the following requirements:

- I The electrical performance is satisfactory.
- I No mechanical adhesion occurs at any movable parts.
- I No dent, bubble, or color change appears in the important materials due to corrosive articles.
- I The salt spray intrusion into the sample does not affect the use of the sample at present or in the future.

Any corrosion needs to be analyzed because it might affect the performance of the sample.

6.1.2 Mechanical Reliability Test

Drop Test

Test three samples according to the sequence shown in the following figure. Test the samples for two cycles. Drop each sample down to the horizontal marble platform from the height of 0.8 meters.

The test result must meet the following requirement: The samples remain intact or suffer only minor mechanical damages after the test.

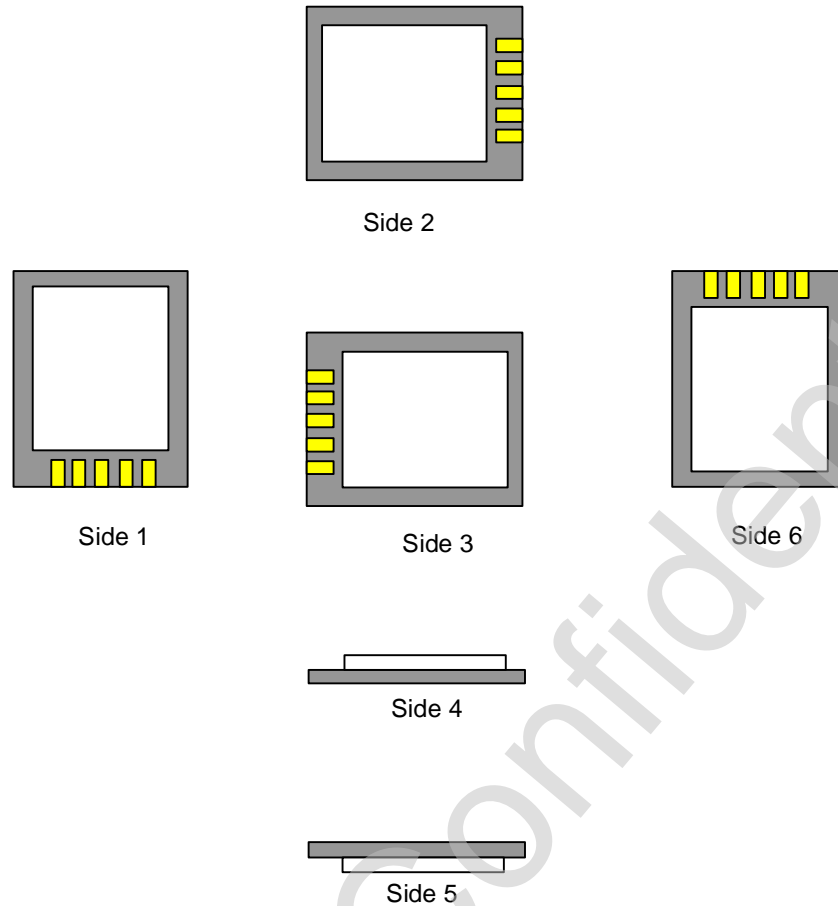

6.1.3 Temperature-Relevant Tests

Temperature Cycling

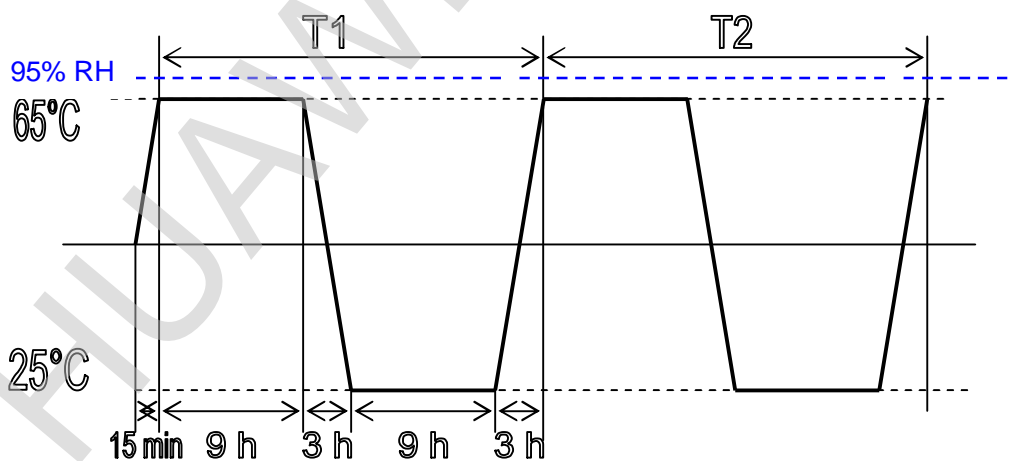

1. Put the module into an incubator and increase the temperature to 65°C in 15 minutes. Test the module at 65°C for nine hours.

2. Decrease the temperature to 25°C in three hours.
3. Test the module at 25°C for nine hours.
4. Increase the temperature to 65°C in three hours.

The four steps constitute a test cycle.

In the test, the relative humidity is 95% and the module keeps working with its maximum power consumption. Test the module for two cycles.

High-Temperature Operation

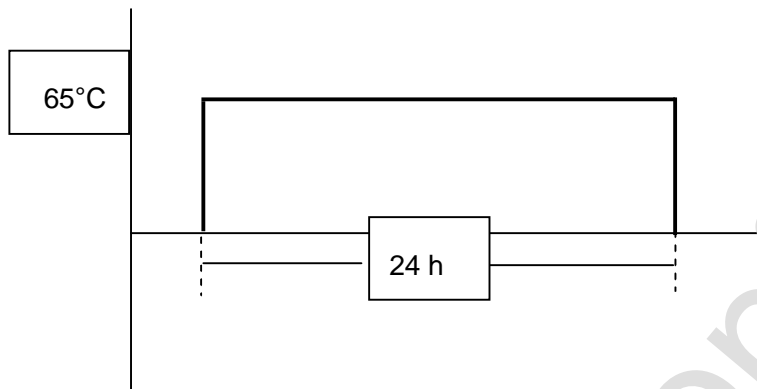

Put the module into an incubator where the temperature is set to 65°C. Keep the module working for 24 hours with its maximum power consumption.

Low-Temperature Operation

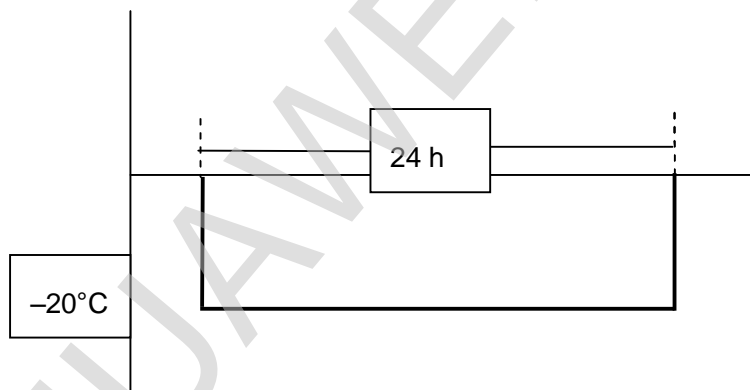

Put the module into an incubator where the temperature is set to -20°C. Keep the module working for 24 hours with its maximum power consumption.

High Temperature Storage

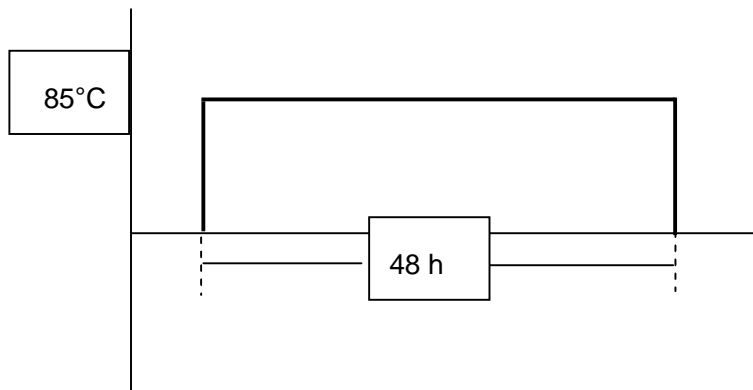

Put the module into an incubator where the temperature is set to 85°C. Keep the module in the incubator for 48 hours with the power supply disconnected.

Low Temperature Storage

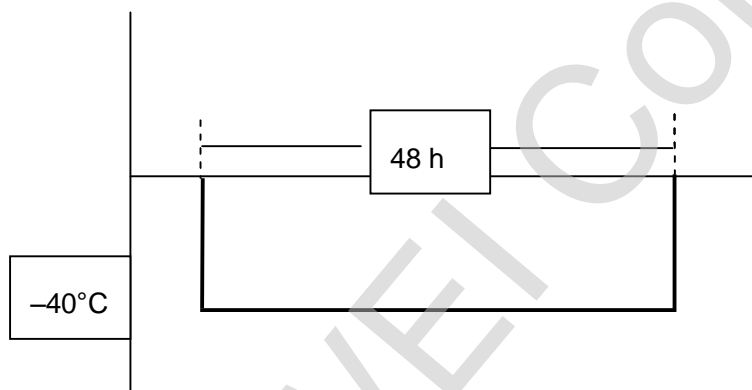

Put the module into an incubator where the temperature is set to -40°C. Keep the module in the incubator for 48 hours with the power supply disconnected.

6.2 Temperature Rise Test

6.2.1 Temperature Rise Test Result

At the ambient temperature, test the surface temperature of the module that works with its maximum power consumption. The following figure shows the specific test points. The tables in this section list the test results at different frequencies.

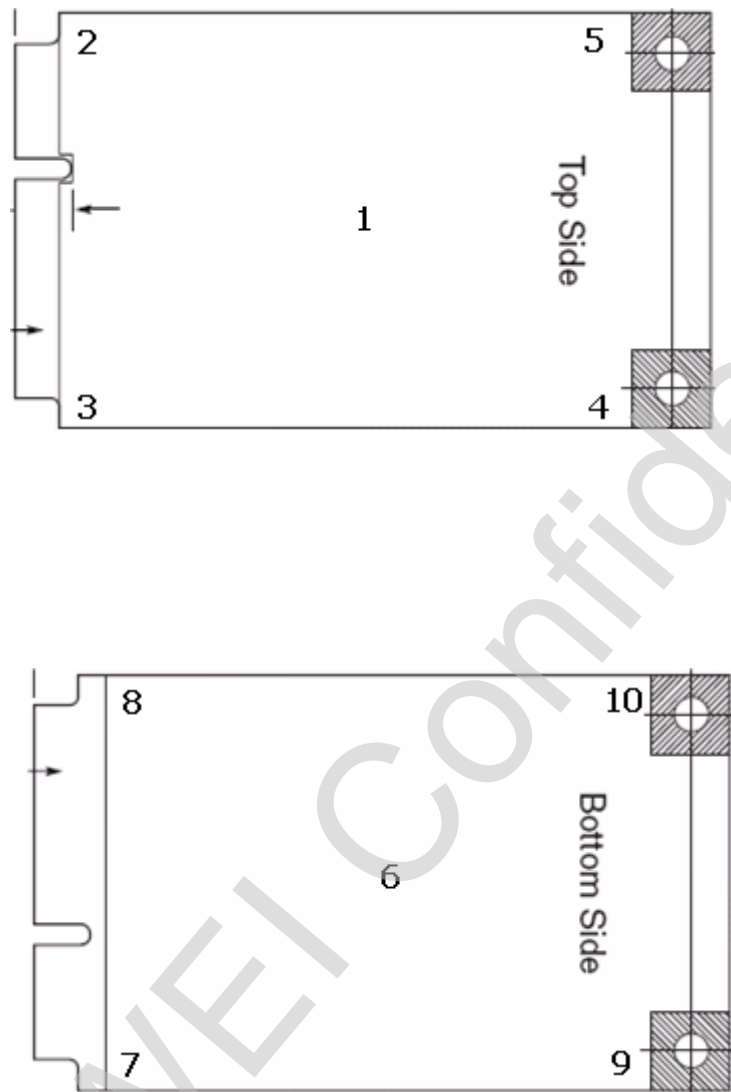

HSDPA 2100 MHz

Access Point	HSDPA 2100MHz
1	53.3°C
2	52.3°C
3	52.0°C
4	52.4°C
5	47.5°C
6	58.9°C
7	52.6°C

Access Point	HSDPA 2100MHz
8	51.6°C
9	52.8°C
10	54.9°C
Environment	25.7°C

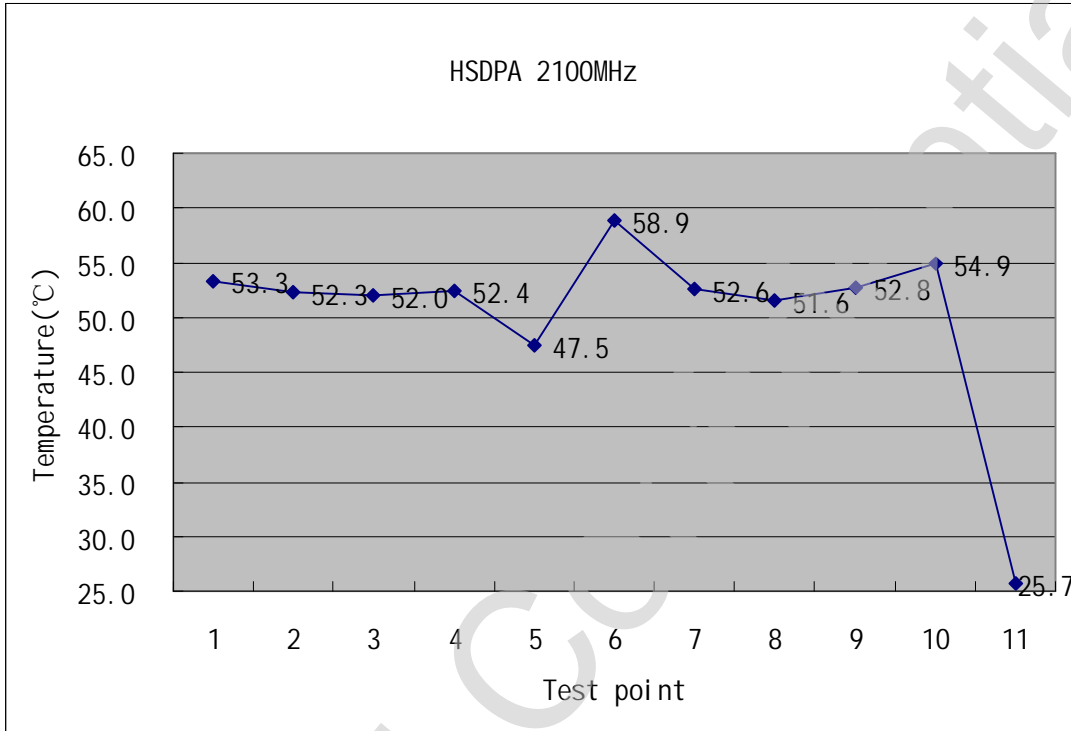

HSDPA 850 MHz

Access Point	HSDPA 850MHz
1	52.1°C
2	52.2°C
3	51.7°C
4	50.9°C
5	47.5°C
6	58.5°C
7	52.9°C
8	45.2°C
9	51.4°C
10	52.9°C
Environment	25.4°C

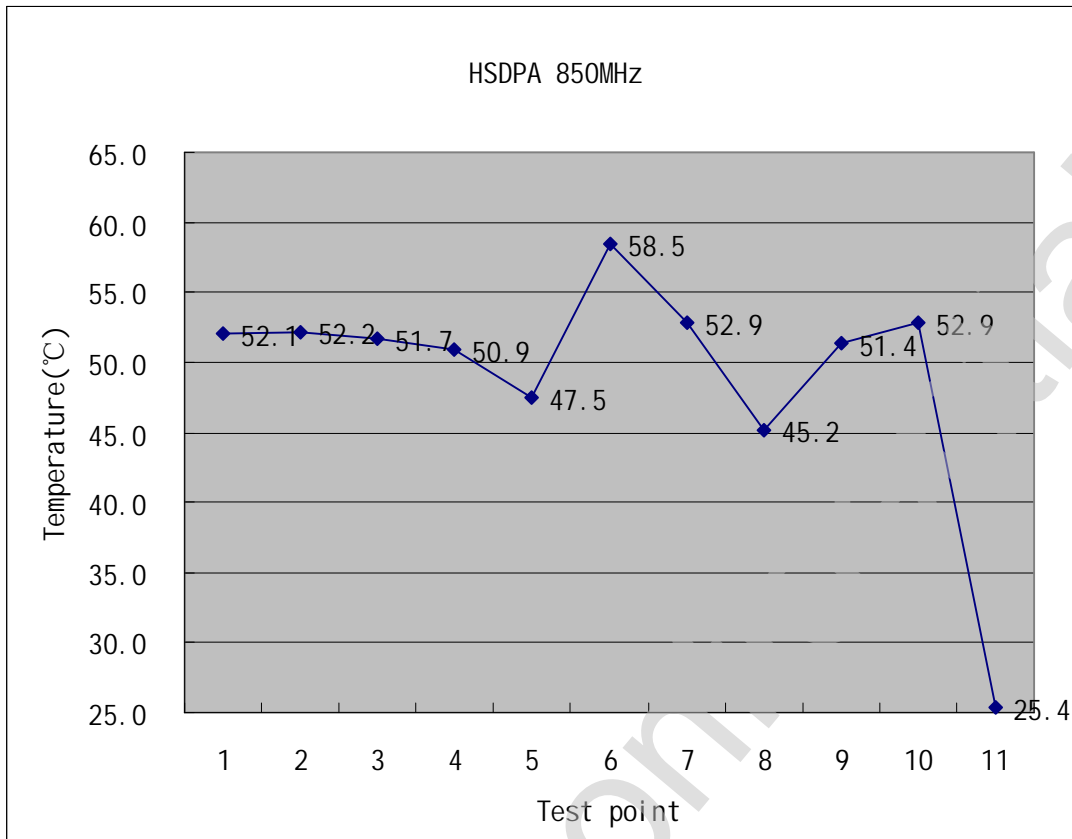

HSDPA 1900 MHz

Access Point	HSDPA 1900MHz
1	55.0°C
2	54.6°C
3	53.5°C
4	51.7°C
5	46.6°C
6	61.5°C
7	54.7°C
8	53.6°C
9	53.2°C
10	54.0°C
Environment	25.9°C

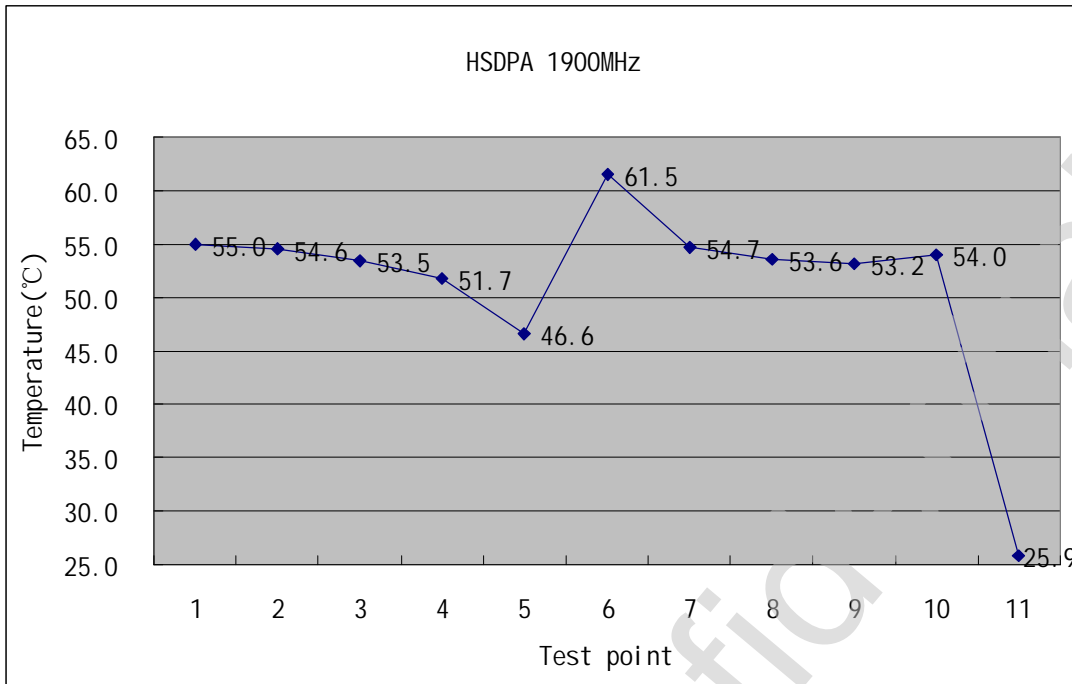

HSDPA 900 MHz

Access Point	HSDPA 900MHz
1	34.7°C
2	52.8°C
3	51.8°C
4	53.9°C
5	48.5°C
6	57.9°C
7	52.0°C
8	51.3°C
9	52.0°C
10	58.0°C
Environment	25.6°C

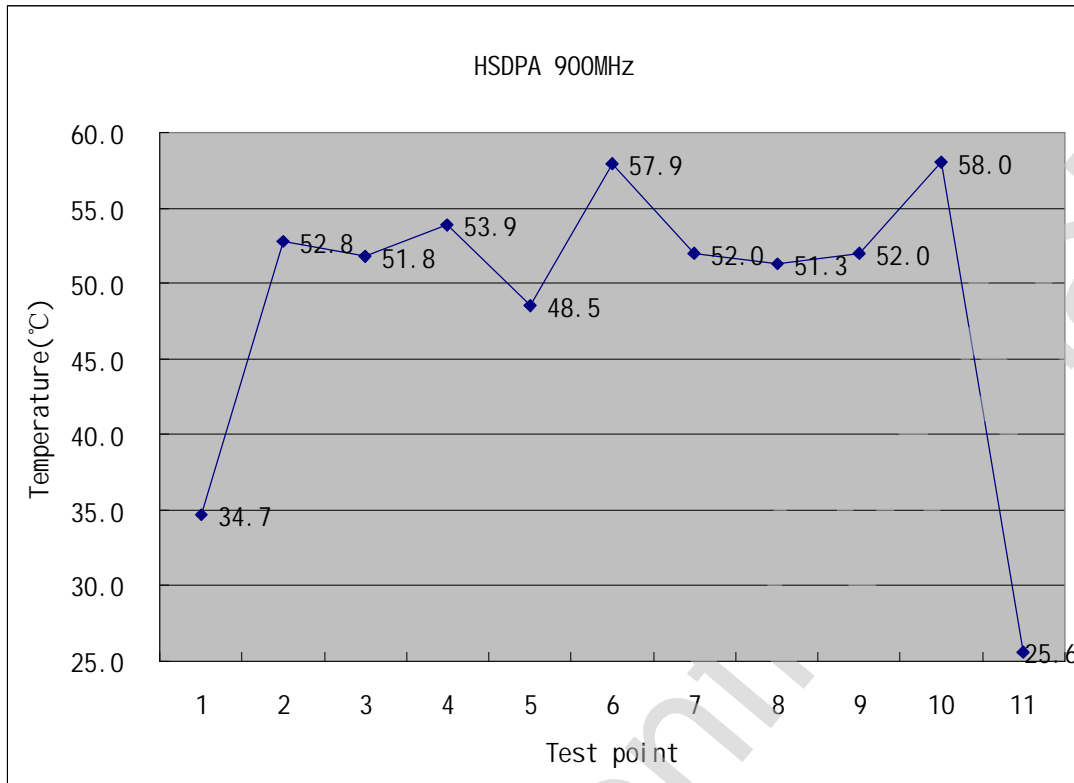

GPRS 850 MHz - 2 Slots

Access Point	GPRS 850MHz-2 Slots
1	32.4°C
2	54.3°C
3	54.6°C
4	51.7°C
5	52.0°C
6	58.9°C
7	53.5°C
8	53.8°C
9	54.4°C
10	55.5°C
Environment	25.5°C

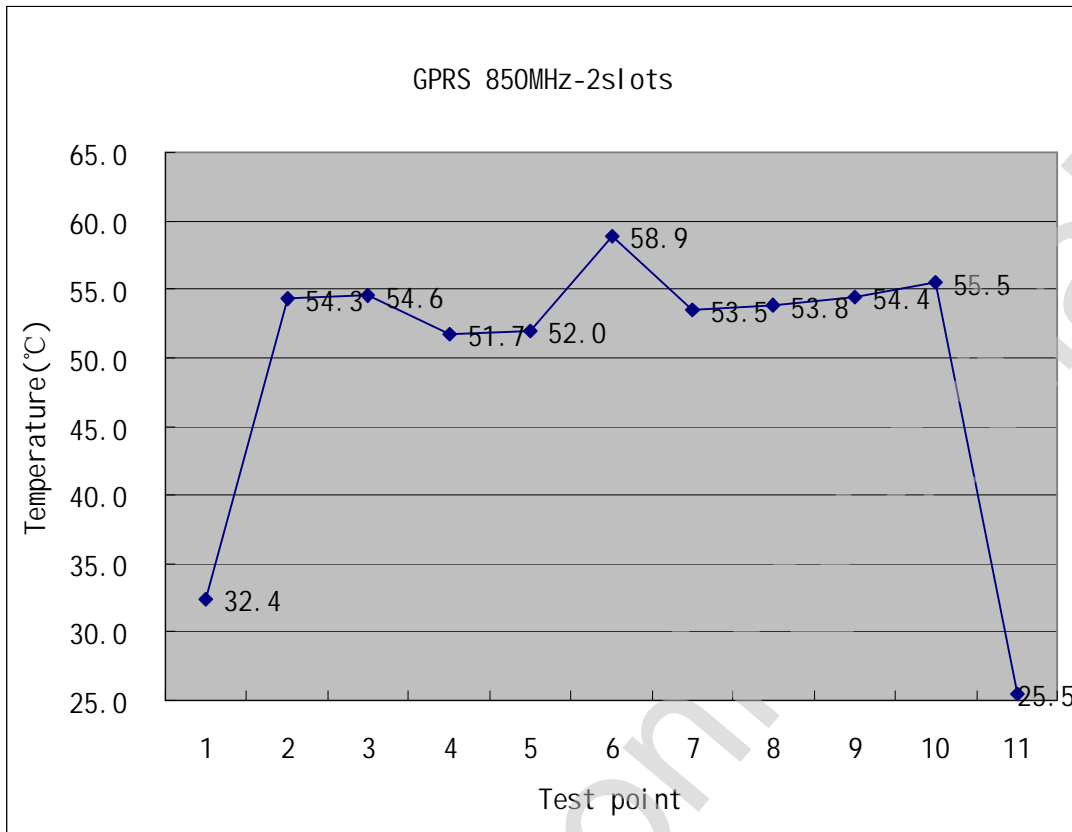

EDGE 850 MHz - 4 Slots

Access Point	EDGE 850MHz-4 Slots
1	32.3°C
2	51.5°C
3	51.1°C
4	49.6°C
5	51.8°C
6	57.5°C
7	51.0°C
8	50.7°C
9	53.6°C
10	54.1°C
Environment	25.6°C

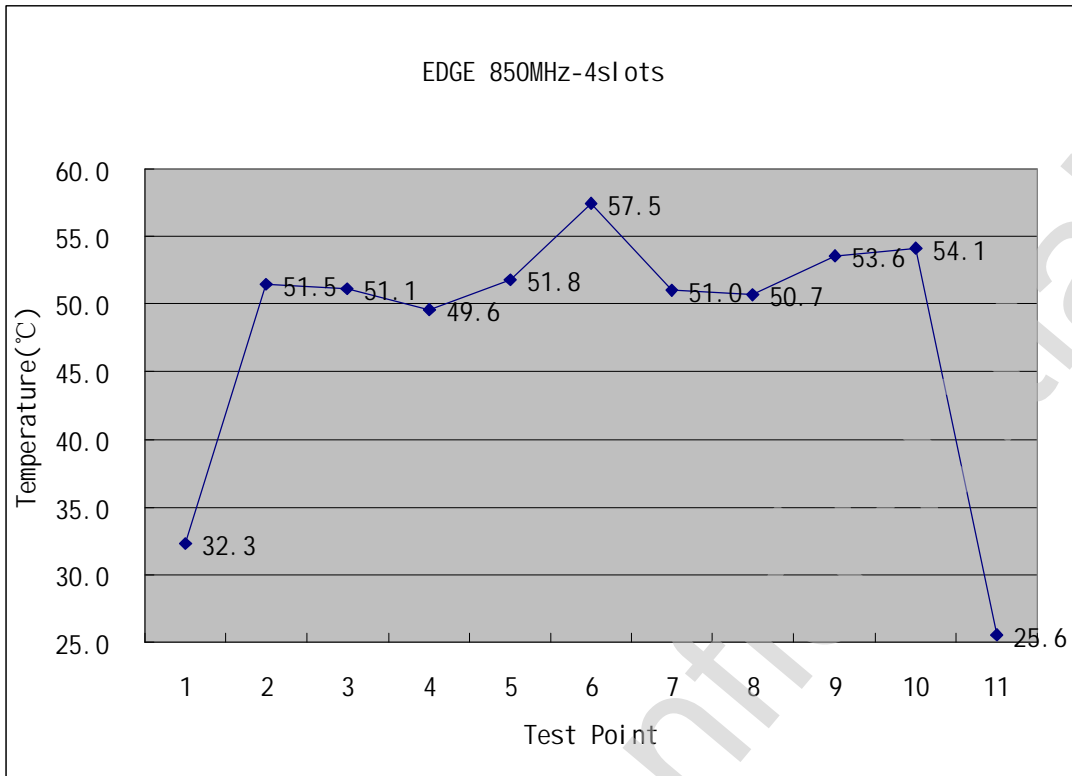

GPRS 1900 MHz - 2 Slots

Access Point	GPRS 1900MHz-2 Slots
1	32.1°C
2	44.7°C
3	43.8°C
4	42.3°C
5	44.0°C
6	48.1°C
7	44.3°C
8	44.1°C
9	45.2°C
10	45.9°C
Environment	25.7°C

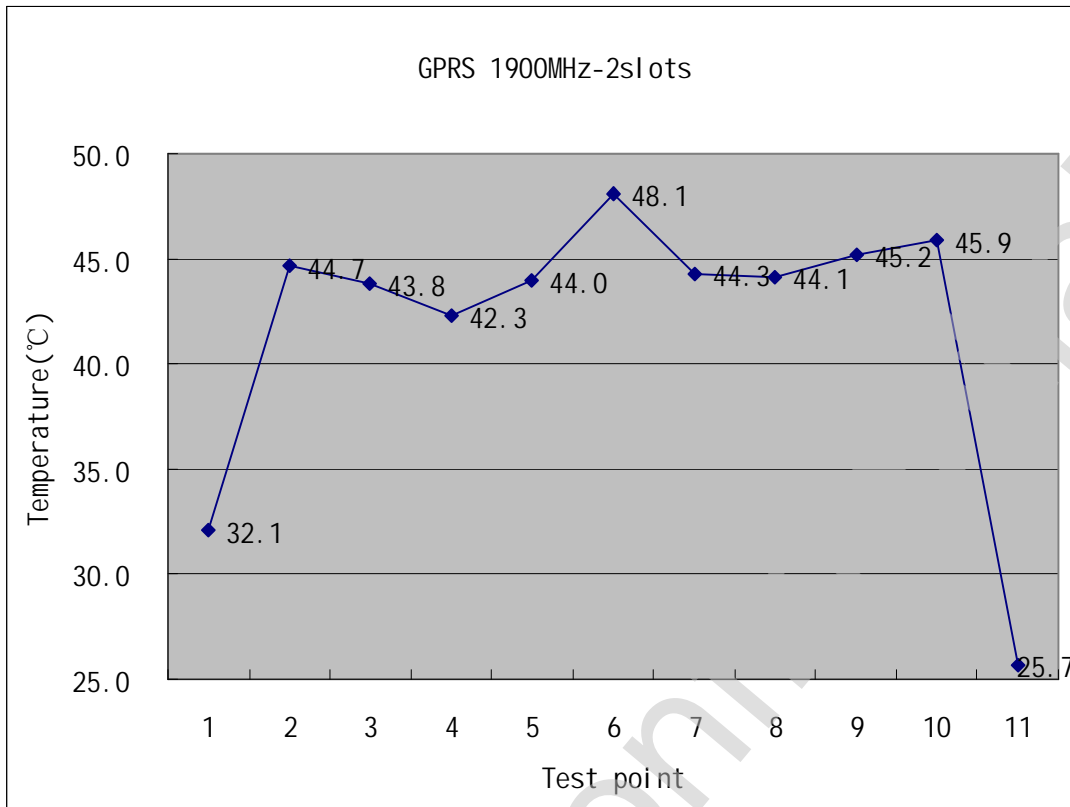

EDGE 1900 MHz - 4 Slots

Access Point	EDGE 1900MHz-4 Slots
1	32.0°C
2	46.8°C
3	46.1°C
4	45.8°C
5	45.5°C
6	51.3°C
7	46.0°C
8	45.7°C
9	47.8°C
10	48.8°C
Environment	25.7°C

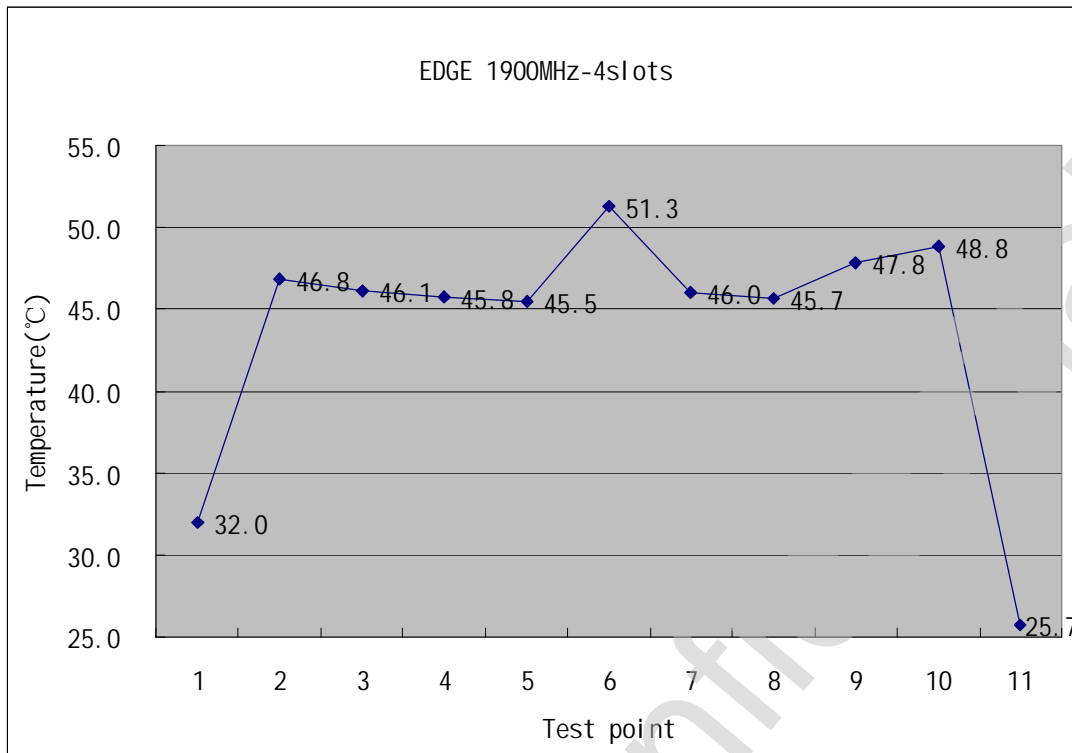

6.3 TRP and TIS

The OTA test is intended to test the radio performance of relevant products through air interfaces. The OTA test measures the radio performance indicators of terminals from the perspective of customers. The US CTIA certification defines the OTA test, and the large-sized operators in Europe and America also put forward their requirements for the OTA test. The following test methods are available:

- I TRP
- I TIS
- I Intermediate channel relative sensitivity

The OTA test is required when the module is integrated to the equipment.

6.3.1 Total Radiated Power

The Total Radiated Power (TRP) test is performed according to the CTIA Test Plan for Mobile Station Over The Air Performance, Revision 2.2.2, December 2008, Section 5. The EUT is positioned in the relevant fix adapter on top of the MAST which also is in the center of the test arch. Then the call is established with the base station simulator. The call parameters are configured in SAM software which remote control the base station simulator so that the EUT can work in required traffic channel and output power level and other proper configurations. The EUT then stepped from 0 to 165 degree along the phi axis in 15-degree increments. At each phi position the SAM software will automatically select the relevant measurement antenna which installed in test arch to measure the data every 15 degrees, both theta and phi polarizations. On completion of the test, all the data acquired will be import to SatEnv then the net power (angular dependent EIRP) is calculated at each measurement point and the

required values of TRP and Near Horizon Partial Radiated Power (NHPRP) are automatically calculated. This test procedure is repeated for each channel, band, and any configuration as required.

6.3.2 Total Isotropic Sensitivity

The Total Isotropic Sensitivity (TIS) test is performed according to the CTIA Test Plan for Mobile Station Over The Air Performance, Revision 2.2.2, December 2008, Section 6. The EUT is positioned in the relevant fix adapter on top of the MAST which also is in the center of the test arch. Then the call is established with the base station simulator. The call parameters are configured in SAM software which remote control the base station simulator so that the EUT can work in required traffic channel and output power level and other proper configurations. The EUT then stepped from 0 to 150 degree along the phi axis in 30-degree increments. At each phi position the SAM software will automatically select the relevant measurement antenna which installed in test arch to measure the data every 30 degrees, both theta and phi polarizations. On completion of the test, all the data acquired will be import to SatEnv then the net power (angular dependent EIS) is calculated at each measurement point and the required values of TIS and Near Horizon Partial Isotropic Sensitivity (NHPIS) are automatically calculated. This test procedure is repeated for each channel, band, and any configuration as required.

6.3.3 Intermediate Channel Relative Sensitivity

The procedure for measuring relative sensitivity on intermediate channel is performed according to the CTIA Test Plan for Mobile Station Over The Air Performance, Revision 2.2.2, December 2008, Section 6. The EUT are moved to the location and polarization resulting in the best-radiated sensitivity measured for the closet, in frequency, fully measured channel, now used as a Reference Channel. The RF signal of the base station simulator is increased by 5dB for both CDMA technologies and GSM technologies over the signal used at the same spherical spatial location for respective Reference Channel. The SAM software will measure the appropriate digital error rate for this test condition. The Frame Error Rate (FER) or Bit Error Rate (BER) should not exceed that found on the Reference Channel and will be reported as Pass/Fail.

The laptop and the module must be regarded as an integrated system for the OTA test and evaluation.

The test results (TIS, TRP, and intermediate channel relative sensitivity) relate to the following factors:

- | Shape of the laptop
- | Antenna
- | LCD
- | Noise caused by the power supply of the laptop
- | Other thermal noise

If the test results (TIS and intermediate channel relative sensitivity) deteriorate severely, improve the isolation, screen and filter noise, or optimize the antennas according to the actual noise sources.

To improve the TRP, improve the antenna gain and reduce the insertion loss at the RF port and the antenna joints or improve the antenna matching.

6.4 Product Certifications

Certification	EM770W
CE	0
FCC	0
SRRC&CCC&CTA	
NCC	0
A-TICK	0
Jate&Telec	
IC	0
EU RoHS	0
JGPSSI	
SGS RoHS	0
PVC-Free	0
GCF	0
PTCRB	0
SUPL 1.0	0

6.5 Environmental Protection Certification and Test

6.5.1 RoHS

RoSH stands for the restriction of the use of certain hazardous substances in electrical and electronic equipment.

The following table lists the substances restricted by the RoHS and upper thresholds of their density.

Restricted Substance	Density Threshold (ppm)
Cadmium (Cd)	100
Lead (Pb)	1000
Mercury (Hg)	1000
Hexavalent chromium (Cr6+)	1000
Polybrominated biphenyls (PBB)	1000
Polybrominated diphenyl ether (PBDE)	1000

The RoHS does not conflict with the following regulations:

- Battery directive
- Cadmium directive (91/338/EEC)
- Directive 2004/12/EC on packaging and packaging waste

Declaration of Conformity (DOC): The product is declared as environment-friendly or as compliant with the environmental protection requirements after internal testing.

Notified body (NB) certification: The product passes the test arranged by a notified body (SGS), and the notified body issues the relevant certificate.

SGS RoHS Test

Tested object: homogeneous material (a material that cannot be mechanically disjoined into different materials) such as metal, plastic, glass, ceramics, solder, and coating

Test method: IEC62321 or equivalent test methods

The following describes the test methods in detail:

▫ XRF scanning

The XRF scanning measurement can only analyze the calibration substances within its applicability scope. For chromium (Cr) and bromine (Br), the XRF scanning result shows only the total chromium and total bromine but not hexavalent chromium, PBB, or PBDE. If chromium or bromine is detected, you need to further test hexavalent chromium, PBB, and PBDE by using other test methods.

The following table lists the required test results.

Element	Polymeric Material	Metallic Material	Electronic Component
Cd	$P \leq (70 - 3\sigma) < X < (130 + 3\sigma) \leq F$	$P \leq (70 - 3\sigma) < X < (130 + 3\sigma) \leq F$	$LOD \leq X < (250 + 3\sigma) \leq F$
Pb	$P \leq (700 - 3\sigma) < X < (1300 + 3\sigma) \leq F$	$P \leq (700 - 3\sigma) < X < (1300 + 3\sigma) \leq F$	$P \leq (500 - 3\sigma) < X < (1500 + 3\sigma) \leq F$
Hg	$P \leq (700 - 3\sigma) < X < (1300 + 3\sigma) \leq F$	$P \leq (700 - 3\sigma) < X < (1300 + 3\sigma) \leq F$	$P \leq (500 - 3\sigma) < X < (500 + 3\sigma) \leq F$
Br	$P \leq (300 - 3\sigma) < X$		$P \leq (250 - 3\sigma) < X$
Cr	$P \leq (700 - 3\sigma) < X$	$P \leq (700 - 3\sigma) < X$	$P \leq (500 - 3\sigma) < X$

▫ Chemical analysis

1. Use the ICP-AES, ICP-MS, and AAS to measure cadmium and lead in polymeric materials.
2. Use the CV-AAS, AFS, ICP-AES, and ICP-MS to measure mercury in polymeric materials, metals, and electronic components.
3. Test the chromized ferrous or non-ferrous metals by using the spot test method or boiling water extraction.

If the spot test fails to provide a definite result, you can perform boiling water extraction to further confirm the test result. If boiling water extraction shows the

presence of hexavalent chromium, it is confirmed that the sample is coated with hexavalent chromium. Measure hexavalent chromium by using the colorimetric method.

4. Use a gas chromatograph (GC) or a mass spectrometer (MS) to measure PBB and PBDE in polymeric materials. Use a high pressure liquid chromatography (HPLC) or a UV detector to measure PBB and PBDE in polymeric materials.

The density of lead, mercury, hexavalent chromium, PBB, and PBDE needs to be lower than 1000 ppm. The density of cadmium needs to be lower than 100 ppm.

6.5.2 WEEE

WEEE stands for the Waste Electrical and Electronic Equipment Directive.

The WEEE mark is on the nameplate of the product. Huawei has concluded recycling agreements with four professional recycling companies in Europe. According to the agreements, the companies are responsible for recycling all Huawei waste equipment in Europe.

The WEEE Directive aims to reduce the amount of electrical and electronic equipment being produced and to encourage everyone to reuse, recycle and recover it.

The rate of recovery reaches 75% by an average weight per product. The reuse and recycling rate of components, materials, and substances reaches 65% by an average weight per product (the additional 10% is for energy recovery). Huawei Technical Support Department also declares the number and weight of the products delivered every year on the European Recycling Platform.

According to the European Recycling Platform and the agreements concluded between Huawei and the recycling companies in EU, the recycling companies specified in the agreements are responsible for recycling the telecommunication products.

6.5.3 PVC-free

PVC-free products are free of polyvinyl chloride (PVC) that is harmful to human beings.

PVC is used to produce soft plastic products such as artificial leather, membrane, and cable sheaths, and hard plastic products such as plates, windows, doors, pipes, and valves.

PVC-free test mainly applies to printed circuit boards (PCBs) and surface mount technology (SMT) components.

A notified body must perform PVC-free tests (qualitative analysis and mixed tests) and then issue relevant test reports.

6.6 National Compulsory Certification

6.6.1 Product Certification

Product certification is the process of certifying that a certain product complies with the electromagnetic compatibility (EMC) safety and qualification requirements

stipulated in relevant international, national, or industrial regulations and issuing relevant test report and certificate.

6.6.2 Importance of Product Certification

The possible violations of EMC rules are as follows:

- | Use certification mark without authorization.
- | Supply products without certification mark.
- | Supply incompatible products or apply certification mark to incompatible products.
- | Make incorrect declarations or no compatibility record is created or kept.

Possible penalties for violation of EMC rules are as follows:

- | Sale forbidden
- | Inventory seizure
- | Compulsory callback
- | Fine
- | Being accused or put into prison

6.6.3 Product Certification Test Items

A product certification test consists of any or any combination of the following items:

- | EMC
Testing electromagnetic interference (EMI) and electromagnetic sensitivity
- | Safety
Testing the product according to relevant safety regulations and ensuring that the product does no harm to users
- | RF
Measuring whether the radio transmitter meets relevant requirements
- | Specific absorption rate (SAR)
Measuring the RF energy absorbed by the body when an electronic product is used

6.6.4 Product Certification Classifications

Product certification is classified into compulsory certification and non-compulsory certification.

- | Compulsory certification
Many countries and regions define compulsory certification marks to facilitate market supervision of the commodity inspection organizations. For example, the Certification Europe (CE) mark, Federal Communications Commission (FCC) mark in U.S.A, and China Compulsory Certificate (CCC) mark are compulsory certification marks. Only the products with required compulsory certification marks can be sold in the relevant countries or regions.
- | Non-compulsory certification
Non-compulsory certification is also called voluntary certification. Compared with compulsory certification marks, the certification marks issued by independent

certification bodies are more common in international trade. The PCS Type Certification Review Board (PTCRB) in America and the Global Certification Forum (GCF) in Europe are two typical examples of non-compulsory certification marks. Non-compulsory certification marks are issued by authorized non-governmental certification bodies based on the product liability laws in relevant countries and are recognized by the local governments. Compared with governmental bodies, non-governmental certification bodies are more professional with better test conditions and more positive certification measures. In addition, non-governmental certification bodies are under supervision of their authorizing administrations. For these reasons, the certification marks issued by non-governmental certification bodies are widely recognized in the market and are essential to international trade.

6.6.5 Certification Modes

I DOC

By affixing a certification mark to a product, the manufacturer declares that the product is compliant with the relevant certification standards. For example, a manufacturer declares that its product complies with relevant EU directives if it affixes a CE mark to the product.

I NB certification

By affixing a certification mark issued by an authorized certification body to a product, the manufacturer declares that the product passes the NB certification tests and complies with the relevant certification standards. The CE0682 mark issued by CETECOM, the UL mark issued by UL, and the GS mark issued by TUV Rheinland are three examples of NB certification marks.

NB certification is used for Huawei modules in most cases.

6.6.6 Certification Types

CE Certification

According to the R&TTE Directive 1999/95/EC, all wireless equipment and telecommunications terminals sold in EU must meet all the stipulated health, safety, RF, and EMC requirements that provide for CE mark. Wireless equipment using frequency bands whose use is not harmonized throughout the EU should pass the certification test of a notified body. Notification should be given no less than four weeks in advance of the start of placing on the market and should provide information about the radio characteristics of the equipment (in particular frequency bands, channel spacing, type of modulation and RF-power) and the identification number of the notified body. The CE mark is a mandatory European mark. Any product placed on the single market in the European Economic Area should be affixed with a CE mark.

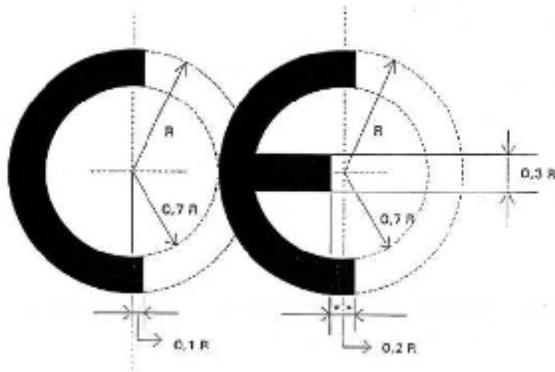

The CE mark of wireless equipment relates to the used frequency bands and the notified body. For this reason, the CE mark on the nameplate consists of letters C and E, the identification number of the notified body, and a  symbol.

C E NBnr

C E NBnr 

FCC Certification

FCC stands for Federal Communications Commission.

The FCC, as an independent agency of the United States government, is charged with regulating interstate and international communications by radio, television, wire, satellite and cable.

FCC regulations, as part of federal laws, are divided into several parts.

Different parts define regulations for different products. A product, however, probably is required to meet the regulations in two or more parts.

All terminals should be certified by the FCC or TCB and granted with an FCC ID.

The FCC ID format is as follows: XXXYYYYYYYY

- I **XXX** is the identification number of the applicant manufacturer (Huawei: QIS).
- I **YYYYYYY** is the product number consisting of two to 14 digits.

An FCCID consists of capital letters in English, digits, and symbols - only. No other character is allowed.

For any Huawei product, the product model is used as the product number. For example, the FCC ID of the EM770W is QISEM770W.

NCC (DGT) Certification

According to *Telecommunications Act* and *Regulations on Inspection and Certification of Controlled Telecommunications Equipment* of Taiwan, no communication and electronic equipment can be manufactured or sold in Taiwan unless certified by the NCC (former DGT) with relevant certification marks.

The following lists the controlled telecommunications equipment:

- I Radio transmitter
- I Radio transceiver
- I Radio receiver
- I Radiated device
- I Other radio sources

The DGT's *Technical Specifications for Low-Power Radio-Frequency Devices* specifies the frequencies that no low-power RF device or its principal wave should not use and control the radiation field strength of low-power RF devices.

Comply with the following rules when making DGT marks:

- I Comply with the *Technical Specifications for Low-Power Radio-Frequency Devices* and the *Compliance Approval Regulations on Controlled Telecommunications Radio-Frequency Devices*.
- I Affix or print marks of appropriate size on the equipment bodies because the dimensions are not specified.
- I Affix or print the DGT mark on the minimal package if the equipment body is small to the mark.
- I Attach the DGT mark to relevant products in compliant with relevant regulations. Ensure that the mark is legible in a single color.

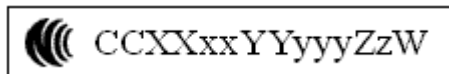

An example of the DGT mark:

A-Tick Certification

The A-Tick is a compliance mark produced by the Australian Communications and Media Authority (ACMA) for telecommunications equipment. The A-Tick indicates that a product is compliant with the mandatory technical and safety standards specified by ACMA and can legally be connected to a telecommunications network in Australia.

All A-Tick certification test items should be performed in local labs in Australia. The test items are as follows:

- I Safety test
- I EMC test
- I SAR test
- I RF test

Some test requirements of the A-Tick certification are the same as those of the CE certification. For this reason, CE certification is accepted in Australia to avoid repeated tests.

The following frequency bands are allocated for mobile communication in Australia at present:

- I 825–845 MHz and 870–890 MHz: The CDMA digital technical standards of North America are used.
- I 890–915 MHz and 935–960 MHz: The GSM digital technical standards of Europe are used.
- I 1710–1785 MHz and 1805–1880 MHz: The GSM digital technical standards of Europe are used.
- I 1885–1980 MHz and 2110–2170 MHz: The 3G mobile communication technologies are to be used.

The A-tick mark is as follows:



TELEC and JATE Certification (Japan)

- I Telecom Engineer Center (TELEC)

TELEC is a compulsory certification for radio products in Japan. The TELEC certification complies with Japanese Radio Law. The specific test regulations are stipulated in MIC Notice No.88 and are updated and maintained by the MIC. All wireless products require type approval (mainly for the RF part) by Japan Telecom before entering Japanese market.

- I JATE

JATE certification is mandatory for telecommunications equipment in Japan according to the Telecommunications Business Law. As specified in article 68 in the Telecommunications Business Law enforced in 1985, the Ministry of Public Management, Home Affairs, Posts and Telecommunications (MPHPT) has the right to designate qualified agencies for technical certification.

The MPHPT designates the Japan Approvals Institute for Telecommunications Equipment (JATE) as the sole authorized agency for technical conditions certification (that is, JATE certification). The JATE provides technical conditions regulatory compliance certifications for telecommunications terminals. The certified equipment can legally be connected to public telecommunications networks without inspection of telecom carriers.

All products certified by the JATE need to be affixed with certification mark shown in the following figure. Sequence numbers are used on the certification marks.

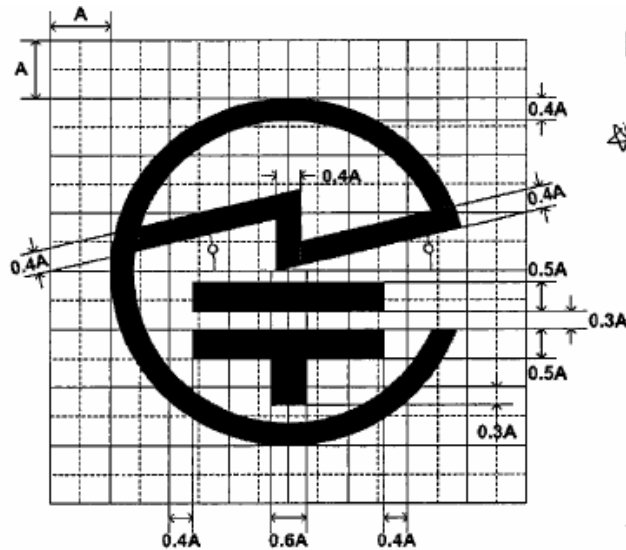

IC Certification (Canada)

IC stands for Industry Canada. As a department of the Government of Canada, the IC stipulates the inspection standards for analog and digital terminals, performs certifications of electrical and electronic products entering the Canadian market, and requires that all electronic products imported to Canada must pass EMC certification. The involved products include broadcast and TV equipment, IT equipment, wireless equipment, telecommunications equipment, and industrial, scientific, and medical (ISM) equipment. Similar to the FCC, the IC applies restrictions on electromagnetic interference only.

The complete IC certification or registration number is as follows:

IC: XXXXXX-YYYYYYYY

I XXXXXX

XXXXXX is the company number issued by the IC (Huawei: 6369A).

I YYYYYYYY

YYYYYYYY is the unique product number (UPN) consisting of up to eight capital letters in English and/or digits.

Chinese Certifications

I Network access licensing (NAL)

The Ministry of Information Industry (MII, former Ministry of Posts and Telecommunications) applies NAL to telecommunications equipment. On January 1, 1999, with the enforcement of the *Administration of the Network Connection of Telecommunications Equipment Procedures* issued by the MII, all telecommunications equipment that access public or private telecommunications networks in China should obtain network access licenses issued by the MII. No telecommunications equipment can be connected to a public telecommunications network or be sold in China without a network access license.

A network access license includes the following information:

- License number
- Applicant

- Manufacturer
- Equipment name
- Equipment type
- Place of manufacture
- Remarks
- Date of issue
- Date of expiry

A network access license often is valid for three years. The Telecommunications Administration Bureau, MII is responsible for inspecting and approving telecommunications equipment and then issuing network access licenses according to the inspection results. Local telecommunication administration departments are responsible for supervising and managing network access of telecommunications equipment in the local regions.

The network access certification is called China Telecommunications Equipment Network Access Approval (TENAA or CTA) or China Telecommunications Equipment Network Access Licensing (NAL).

NAL marks should meet the following requirements:

- NAL marks are the quality compliance marks affixed to the telecommunications equipment that obtains network access licenses.
- NAL marks are printed and issued by the MII.
- NAL marks can be purchased for the equipment that obtains network access licenses.
- NAL marks should be affixed firmly to the telecommunications equipment that obtains network access licenses.
- Forging or illegally using NAL marks is forbidden. No NAL mark can be affixed to the telecommunications equipment that fails to obtain network access licenses or whose network access licenses expire.

The following figure shows an example of NAL marks.



The following figure shows the anti-counterfeiting measures of NAL marks.

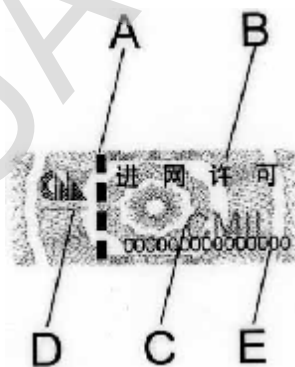

- A means the fluorescent anti-counterfeiting string inside the mark. The anti-counterfeiting string is visible under UV light and can be exposed with a knife.

- B means the anti-counterfeiting shading that supports anti-photography and anti-forgery.
- C means the invisible CMII fluorescent mark that is visible under UV light.
- D means the characters that use microform printing.
- E means the unique computer scrambling code that relates to the license number, equipment type, and sequence number. The scrambling code cannot be copied.

I Type approval

On July 24, 1995, the former State Radio Regulatory Committee (SRRC), the State Economic and Trade Commission (SETC), the General Administration of Customs (GAC), and the Ministry of Foreign Trade and Economic Cooperation (MFTEC) jointly issued the *Provisions on the Management of Import of Radio Transmission Equipment*. In April 1999, the Ministry of Industry and Information Technology of the People's Republic of China (MIIT) issued the *Notice of Strengthening Management of Radio Transmission Equipment*. As stipulated in the provisions and notice, manufacturers of all radio transmission equipment sold in China should possess the *China Radio Transmission Equipment Approval Certificate* issued by the SRRC and the relevant CMIIT ID should be affixed to the equipment nameplates.

Telecommunication equipment manufacturers should submit the *China Radio Transmission Equipment Approval Certificate* when applying for a network access license to the MIIT. In other words, completion of equipment type approval is one of the prerequisites for network access application.

The relevant CMIIT ID should be marked on the nameplate of Huawei radio terminals according to article 4 in the *Provisions on Management of Manufacture of Radio Transmission Equipment*.

The following shows an example of the CMIIT ID:

xxxxCPxxxx

xxxx before the letters **CP** is four Arabic numerals, indicating the year of issue of the certificate. **xxxx** following the letters **CP** is four Arabic numerals, indicating the sequence number of the certificate.

I CCC

The China National Certification and Accreditation Administration of People's Republic of China (CNCA) is responsible for managing and organizing the CCC. The CCC mark is a compulsory safety mark for the products covered in the *List of the First Group of Products Being Required Compulsory Product Certification* when the products are sold on the Chinese market. No listed product can be imported, sold, or used in China without a CCC certificate issued by designated certification bodies or without a CCC mark.

CCC marks are classified into standard and non-standard marks. Huawei products use non-standard CCC marks.



RoHS, REACH, JGPSSI, and Chinese Environmental Protection

- 1 RoHS: the restriction of the use of certain hazardous substances in electrical and electronic equipment

According to RoHS directive, all electrical and electronic products sold on the EU market should be free of the following six hazardous substances as of July 1, 2006:

- lead
- Mercury
- Cadmium
- Hexavalent chromium
- PBB
- PBDE

The maximum permitted concentrations of the six substances are specified as follows:

- The maximum permitted concentrations of lead, mercury, hexavalent chromium, PBB, and PBDE are 1000 ppm (0.1%) by weight of homogeneous material.
- The maximum permitted concentration of cadmium is limited to 100 ppm (0.01%).



The EU does not specify any RoHS mark. Huawei, however, designs the preceding RoHS mark to distinguish between environment-friendly and environment-unfriendly products. For Huawei RoHS marks, any color is acceptable.

- 1 REACH: Regulation (EC) No. 1907/2006 of the European Parliament and of the Council of 18 December 2006 concerning the Registration, Evaluation, Authorization and Restriction of Chemicals (REACH)

The REACH entered into force on June 1, 2007 and was implemented as of June 1, 2008.

The REACH Regulation is a mandatory preventative regulation on all chemicals sold on the EU market.

The REACH Regulation creates a large complex chemical management system that transfers the chemicals safety responsibility from the government to the industry. Manufacturers, importers, and downstream users are held responsible for the safety of the chemicals used in their products.

The REACH Regulation specifies that a substance is regarded as hazardous until proven safe. The earlier EU chemical regulations, however, specifies that a substance is regarded as safe until proven hazardous.

I JGPSSI: Japan Green Procurement Survey Standardization Initiative

The JGPSSI was established by some Japanese electrical and electronic enterprises in January 2001. Since its establishment, the JGPSSI has been researching on standardization of green procurement of electrical and electronic products. The JGPSSI issued and promoted guidelines for management of chemical substances in products in July 2003.

The JGPSSI divides the management of chemicals into the following three processes:

- Acquisition of content information for purchased materials (IN information): Obtain content information (IN information) for each substance/preparation and each article, and confirm the reliability of the content information.
- Manufacture of products using those materials in a manufacturing process: Increase the reliability in the daily quality management activities, such as preventing the content of incorrect components and preventing contamination by substances/preparations or articles that contain prohibited substances.
- Provision of content information for the products sold (OUT information): Improve reliability by providing content information (OUT information) for each substance/preparation or article.

I China Environmental protection: *Administrative Measures on the Control of Pollution Caused by Electronic Information Products* that is similar to EU's RoHS

- When designing and manufacturing electronic information products, the manufacturers should use materials, technologies, and processes that are easily recyclable and environment-friendly in accordance with the relevant industrial or national standards.
- All electronic information products sold on Chinese market should be marked with the names and contents of toxic and harmful substances and elements, safety period, and recyclability.
- The use of six hazardous substances is prohibited or limited in the products listed in the administrative catalogue for the control of pollution caused by electronic information products. The catalogue is not determined at present. It is estimated that the first catalogue is to be issued at the end of year 2009. Printers, telephones, and mobile phones might be listed in the catalogue.
- The control of toxic and harmful substances in electronic information products is covered in the CCC management.
- Six hazardous substances are prohibited, including lead, mercury, cadmium, hexavalent chromium, PBB, and PBDE. Other hazardous substances defined by China are also prohibited.
- No exemption clause is defined in the *Administrative Measures on the Control of Pollution Caused by Electronic Information Products*.

The *Marking for the Control of Pollution Caused by Electronic Information Products* (SJ/T11364-2006) issued on November 6, 2006 specifies that the mark should indicate whether the electronic information products contain any toxic or hazardous substances or elements, the safety period, and the recyclability of the products.

- The mark shown in the left figure is used by the products that are free of any toxic or hazardous substances or elements.

- The mark shown in the right figure is used by products that contain toxic or hazardous substances or elements. The user manuals of the products should indicate the names and contents of the toxic or hazardous substances or elements. The number in the middle of the mark indicates the safety period of the specific product. The safety period of a product will be determined in accordance with the *General Guidelines of Environment-Friendly Use Period of Electronic Information Products* to be issued.



6.6.7 Guide to Product Certification

CE Certification and FCC Certification

Huawei modules pass the RF, EMC, and safety specifications tests and obtain relevant certificates issued by notified certification bodies.

In the case of certification of the laptops installed with Huawei modules, the relevant test reports of Huawei modules can be directly used in accordance with the following rules:

- I The conductivity test data in the Huawei RF test report can be directly used by the laptop manufacturer.
- I The laptop manufacturer should determine whether the radio test data in Huawei RF test report can be used according to the antenna gain.
 - The radio test data in Huawei RF test report can be directly used if the antenna gain of the laptop is lower than that used in the certification test of Huawei modules.
 - The laptop manufacturer should test antennas of the laptops if the antenna gain of the laptop is higher than that used in the certification test of Huawei modules.
- I The laptop manufacturer should test the compliance of the laptops with EMC and safety specifications.
- I The SAR of the laptops needs to be tested only if the antennas of the laptops are within 20 cm of people.

IC Certification

Huawei applies for IC certificate to the relevant certification bodies by using an IC test report converted from the FCC test report.

NCC Certification

Huawei mails a sample module to the ADT of Taiwan. The ADT then performs relevant tests and issues an NCC certificate.

6.6.8 Nameplate



- 1: Product model
- 2: WEEE compliance mark
- 3: EU's RoHS mark
- 4: FCC ID
- 5: CE mark and notified body number
- 6: IMEI number
- 7: Serial number
- 8: Part number

6.7 GCF and PTCRB

Conformance test and declaration are required for establishing that the GSM and WCDMA terminals to be sold in a region meet the requirements of the local carriers and networks.

Global Certification Forum (GCF) and PTCRB certifications are recognized in most regions all around the world. Most operators all round the world accept either certification as one of the market entry conditions.

6.7.1 GCF Certification

The GCF is an active partnership between European mobile device manufacturers and mobile network operators.

According to the R&TTE Directive 1999/95/EC issued in 2001, authorized test organizations or manufacturers should perform final conformance tests of GSM terminals in compliance with the GCF certification criteria (GCF-CC). Manufacturers then should prepare a DOC and take all responsibilities for quality of the equipment.

The GCF officially launched the 3G WCDMA certification program in February 2005.

The GCF plays an important role in protocol and application conformance testing. The GCF provides harmonized standards for conformance tests and defines a test system approved by all members to ensure that the terminals meet network deployment requirements. All GCF members approve the terminals if the terminals are certified by the GCF. The GCF certifies both test cases and test systems. The GCF certification originates in Europe and now is accepted by mainstream operators in both Europe and Asia.

The GCF certification is a DOC of equipment manufacturers. Equipment manufacturers only need to perform the test items defined by the GCF and then submit a DOC on the GCF website. All GCF members can view the desired DOC on the GCF website.

The test system defined by the GCF requires thorough conformance tests of terminals. The test system consists of indoor and outdoor tests.

- I Outdoor tests mean field testing of terminals in actual networks. Outdoor tests are often performed in the networks of large European operators.
- I Indoor tests include protocol conformance testing and application conformance testing.
 - Protocol conformance testing aims to test terminals' conformance with 3GPP communication protocols, including GSM and WCDMA protocols.
 - Application conformance testing aims to test terminals' conformance with widely used applications such as browsers, SUPL, MMS, and VT.

The OMA and the IMTC specify operation and interaction specifications of such upper-layer applications. Application conformance testing is based on the test standards defined by the OMA and the IMTC.

Terminals are not required to pass all the GCF tests. GCF tests are classified into the following types:

- I Mandatory tests: Mandatory tests mean the tests that the terminals supporting the GSM or WCDMA system must pass. Mandatory tests cover the capabilities that a terminal must have when it supports communications in the relevant system (GSM or WCDMA).
- I Optional tests: Optional tests refer to the tests that the terminals supporting a feature specified in the 3GPP protocol or the OMA or IMTC protocols must pass. If a manufacturer is unwilling to perform such tests for its terminals, the manufacturer should declare that the terminals do not support the related features and not claim that the terminals support the related features when releasing the terminals to the market.
- I Unnecessary tests: The GCF does not require the terminals to pass all the tests specified by the 3GPP, OMA, or IMTC. The tests that are not relevant need not to be performed.

As the GCF test items need to be updated frequently to meet the requirements of new communication technologies, the GCF updates the GCF-CC version continuously. Usually the number of test items increases every time a new GCF-CC version is released and terminals are required to pass an increasingly large number of tests.

The current GCF-CC version is 3.35. The GCF updates the GCF-CC version every two or three months. The previous version is rendered obsolete 110 days after a new version is released. All terminal manufacturers need to pay attention to the 110-day rule because additional test items are required after the previous version becomes obsolete. All GCF members can view the latest GCF-CC version, the currently available version, and the validity period published on the GCF website.

6.7.2 PTCRB Certification

The PTCRB requirements are certification standards in North America.

The PTCRB was created in March 1997. GSM 850 MHz requirements were added to the PTCRB requirements in May 2001, which is an important development milestone in the history of standardization organizations in U.S.A. Similar to the GCF, the PTCRB comprises of operators and mainstream mobile phone manufacturers, and approved laboratories. The PTCRB was created by North American operators (Cingular, T-Mobile, and Rogers) and is applied to North America, Central America, and South America. The PTCRB certification is similar to the GCF certification, except that the PTCRB certification acts as the license for the UMTS terminals to be connected to American operators' networks. Only the PTCRB certified terminals are accepted by mainstream operators.

The PTCRB certification also differs from the GCF certification in the frequency bands because the frequency bands used in America differ from those in Europe. The PTCRB focuses on the GSM 850 MHz, GSM 1900 MHz, WCDMA FDD II, and WCDMA FDD V, while the GCF focuses on the GSM 900 MHz, GSM 1800 MHz, and WCDMA FDD I.

Different from the GCF certification, the PTCRB certification does not allow DOC. The entire certification process should be performed under the PTCRB's supervision and all the certification tests should be performed in the labs authorized by the PTCRB. A manufacturer who applies for the PTCRB certification needs to submit a test application to the PTCRB, and then the PTCRB will transfer the application to the test organization designated by the manufacturer. The test organization should perform the test and then submit the test report to the PTCRB for review. The PTCRB certification is completed if the PTCRB approves the test report. The PTCRB should also publish the certification on its website for viewing and querying by the PTCRB members.

The PTCRB certification is similar to the GCF certification in terms of test system. The only difference is that no field testing is performed in the case of the PTCRB certification. OTA tests are adopted to measure the antenna performance. The PTCRB test items and version are also updated continuously. Different from the GCF-CC version, only one PTCRB version is valid at any time. Each PTCRB version is valid for three months. Manufacturers are not allowed to apply for the previous version of PTCRB certification if a new version is released. For a terminal for which the manufacturer has applied for the previous version of PTCRB certification before the new version is released, the manufacturer needs not to apply for the new version if the PTCRB certification is completed within nine months.

6.7.3 Overall-System Certification

Both the test system and test items of the GCF certification are similar to those of the PTCRB certification. Both certifications test the declared capabilities of terminals based on the 3GPP test standards. The integrated equipment needs to pass relevant certification tests, even though the modules pass the conformance certification. The following describes the overall-system certification procedures in detail. The overall-system can be a notebook, a MID, a smartphone, etc.

Overall-System GCF Certification

Huawei modules pass the GCF certification before being released to the market. Huawei performs 2000 to 3000 test items for each type of modules. The major tests are as follows:

- I Protocol conformance test
- I RF conformance test
- I SIM/USIM conformance test

The details about the certification tests are defined in the 3GPP test standards.

According to the GCF-CC, the test reports of modules can be used for the overall-system certification. The changed parts, however, need to be re-tested. Regarding the product structure, the antennas and SIM card interface circuits are modified in the integrated equipment. For this reason, the antennas and the SIM card interface circuits need to be re-tested in the overall-system certification.

- I Field test

The antenna performance-relevant field test is required due to changes in the antennas and to test the equipment's functions and its interoperability with networks on five networks run by different European operators. To be specific, the field test tests the basic functions of the UE on actual networks and determines whether the UE passes the testing according to the UE performance.

- I SIM/USIM test

SIM card interface circuits are re-designed in the integrated equipment, which may result in changes in the electrical features of the SIM card interface. For this reason, the SIM card interface circuits need to be re-tested. The SIM/USIM test aims to verify the overall performance of SIM/USIM interface with appropriate test instruments in accordance with the relevant 3GPP protocol requirements.

Huawei provides a test report of the product to be certified for the customers who require the GCF certification. The test report is issued by an organization designated for GCF certification. The test report covers the Protocol Implementation Conformance Statement (PICS) and the test information on the product. The PICS is a conformance statement of the product and a basis for GCF certification. The test information includes the performed test items and results of the product. The test organization can issue a certification report of the integrated equipment after performing the required field test and SIM/USIM test based on the test report provided by Huawei.

Terminal manufacturers who apply for the GCF certification of the terminals to be integrated with Huawei modules must accomplish the following tasks:

1. Register as a member of the GCF.

The GCF certification is a DOC. Only GCF members can submit their DOC on the GCF website. Contact the GCF if you need to join the GCF. Proceed with the following steps if you are a GCF member.

2. Choose a test organization.

The GCF does not designate its test organizations. All test organizations that meet the GCF test conditions can perform GCF tests. In this case, it is necessary for manufacturers to choose a well-recognized test organization that provides high quality and high efficiency services. The global test organizations 7layers, SGS, and CETCOM are recommended. The recommended test organizations have built various labs all around the world and work closely with the GCF and the PTCRB. Therefore, the test organizations are able to provide high quality and high efficiency test services and are widely recognized by operators.

3. Discuss test details with the test organization.

Provide the test organization with the test report of Huawei modules and the modifications of the integrated equipment. The test organization then can determine the detailed test items and determine the test schedule accordingly. With the detailed test items and schedule, terminal manufacturers can determine accurate plans of product development and marketing.

4. Perform overall-system certification.

The integrated equipment can pass the over-all certification test easily if Huawei's design suggestions are complied with.

5. Obtain the test report and the DOC.

The test report describes the details about the overall-system test that operators are concerned about. The GCF certification is completed upon uploading of the DOC to the GCF website.

Overall-System PTCRB Certification

Huawei modules pass the PTCRB certification before being released to the market. Huawei performs 2000 to 3000 test items for each type of modules. The major tests are as follows:

- I Protocol conformance test
- I RF conformance test
- I SIM/USIM conformance test

The details about the certification tests are defined in the 3GPP test standards.

According to the PTCRB certification criteria, the test reports of modules can be used for the overall-system certification. The changed parts, however, need to be re-tested. Regarding the product structure, the antennas and SIM card interface circuits are modified in the integrated equipment. For this reason, the antennas and the SIM card interface circuits need to be re-tested in the overall-system certification.

I OTA test

Different from the GCF certification, the PTCRB certification does not require field testing. The antenna performance is verified through OTA tests. OTA tests are defined by the CTIA for verifying antenna performance.

I SIM/USIM test

SIM card interface circuits are re-designed in the integrated equipment, which may result in changes in the electrical features of the SIM card interface. For this

reason, the SIM card interface circuits need to be re-tested. The SIM/USIM test aims to verify the overall performance of SIM/USIM interface with appropriate test instruments in accordance with the relevant 3GPP protocol requirements.

Similar to the GCF certification, the PTCRB certification requires a small number of test items for integrated equipment. In addition, the required test items are easy to perform with appropriate design suggestions. Huawei also provides customers with a PTCRB test report of the module. The test is a basis for the PTCRB certification of the equipment integrated with the module.

Terminal manufacturers who apply for the PTCRB certification of the terminals to be integrated with Huawei modules must accomplish the following tasks:

1. Register as a guest of the PTCRB.

Different from the GCF, the PTCRB comprises of only operators. Terminal manufacturers can join the PTCRB only as guests. The terminal manufacturers who apply for the PTCRB certification have to register as PTCRB guests as they must submit the application on the PTCRB website.

2. Choose a test organization.

The PTCRB requires only qualified test organization to perform PTCRB tests. In this case, it is necessary for manufacturers to choose a well-recognized test organization that provides high quality and high efficiency services. The global test organizations 7layers, SGS, and CETCOM are recommended. The recommended test organizations have built various labs all around the world and work closely with the GCF and the PTCRB. Therefore, the test organizations are able to provide high quality and high efficiency test services and are widely recognized by operators.

3. Discuss test details with the test organization.

Provide the test organization with the test report of Huawei modules and the modifications of the integrated equipment. The test organization then can determine the detailed test items and determine the test schedule accordingly. With the detailed test items and schedule, terminal manufacturers can determine accurate plans of product development and marketing.

4. Submit an overall-system certification application on the PTCRB website and designate a test organization.

Submit a test application on the PTCRB website, indicating the basic information of the terminal to be certified. The PTCRB then transfers the application to the designated test organization. Remember to pay the CTIA after you submit a test application. Unpaid applications are rejected even though all the required tests are performed.

5. Perform overall-system certification.

The integrated equipment can pass the over-all certification test easily if Huawei's design suggestions are complied with.

6. Obtain the test report and submit relevant materials.

The PTCRB test report is provided by the test organization. The terminal manufacturer, however, is required to provide the user manual and other necessary documents of the terminal to be certified on the PTCRB website before the PTCRB test application can be approved. In addition, the PTCRB submits all the materials to the CTIA for review on completion of all the PTCRB tests. The terminal is PTCRB certified on completion of the CTIA review.

GCF and PTCRB Certification

To launch a terminal in the global market, both the GCF certification and the PTCRB certification are required. In this case, the manufacturer does not need to conduct two end-to-end tests. As the SIM test is the same for both the GCF certification and the PTCRB certification, the test organization needs to perform the SIM test only once. This practice is recognized by both the GCF and the PTCRB. The cost, including time and expense, of overall-system certification is thus reduced.

7 Technical Reference

7.1 Layer 1 Specifications (Physical)

- | Examples of Channel Coding and Multiplexing TR 25.944
- | Physical Layer–General Description TS 25.201
- | Physical Channels and Mapping of Transport Channels onto Physical Channels (FDD) TS 25.211
- | Multiplexing and Channel Coding (FDD) TS 25.212
- | Spreading and Modulation (FDD) TS 25.213
- | Physical Layer–Procedures (FDD) TS 25.214
- | Physical Layer–Measurements (FDD) TS 25.215
- | 3GPP HSDPA overall description 25.308
- | 3GPP HSUPA overall description 25.309
- | 3GPP UE radio access capabilities 25.306

7.2 Layer 2 Specifications (MAC/RLC)

- | MAC Protocol Specification TS 25.321
- | RLC Protocol Specification TS 25.322

7.3 Layer 3 Specifications (RRC)

- | UE Interlayer Procedures in Connected Mode TS 25.303
- | UE Procedures in Idle Mode TS 25.304
- | RRC Protocol Specification TS 25.331

7.4 Layer 3 NAS/Core Network (MM/CM)

- | Architectural Requirements for Release 1999 TS 23.121
- | NAS Functions Relevant to Mobile Station (MS) in Idle Mode TS 23.122
- | Mobile Radio Interface Signaling Layer 3–General Aspects TS 24.007

- | Mobile Radio Interface Layer 3 Specification–Core Network TS 24.008
- | PP SMS Support on Mobile Radio Interface TS24.011

7.5 GSM Protocol Specifications

- | Mobile Radio Interface Layer 3 Specification, Radio Resource Control Protocol TS 04.18
- | Mobile Station–Base Station System (MS–BSS) interface; Data Link (DL) Layer Specification TS 04.06
- | Digital Cellular Telecommunications System (Phase 2+); Multiplexing and Multiple Access on the Radio Path TS 05.02
- | Technical Specification Group GERAN; Channel coding TS 05.03
- | Digital Cellular Telecommunications System (Phase 2+); Radio Subsystem Link Control TS 05.08
- | Digital Cellular Telecommunications System (Phase 2+); Radio Subsystem Synchronization TS 05.10

7.6 GPRS Protocol Specifications

- | Overall Description of the GPRS Radio Interface; stage 2 TS 3.64
- | Mobile Radio Interface Layer 3 Specification TS 04.08
- | Mobile Radio Interface Layer 3 Specification: Radio Resource Control Protocol TS 04.18
- | General Packet Radio Service (GPRS): Mobile Station (MS)–Base Station System (BSS) interface; Radio Link Control/Medium Access Control (RLC/MAC) protocol TS 04.60
- | Mobile Station–Serving GPRS Support Node (MS–SGSN) Logical Link Control (LLC) Layer Specification TS 04.64
- | Mobile Station–Serving GPRS Support Node (MS–SGSN); Subnetwork Dependent Convergence Protocol (SNDCP) TS 04.65
- | Multiplexing and Multiple Access on the Radio Path TS 05.02
- | Channel Coding TS 05.03
- | Modulation TS 05.04
- | Radio Transmission and Reception TS 05.05
- | General Packet Radio Service (GPRS); Stage 1 TS 22.060
- | Mobile Execution Environment (MexE) TS 23.057
- | General Packet Radio Service (GPRS) Service description; stage 2 TS 23.060

7.7 General Specifications

- | UE Capability Requirements TR 21.904
- | UE Radio Access Capabilities TR 25.926
- | Vocabulary TR 25.990

- | Radio Interface Protocol Architecture TS 25.301
- | Services Provided by the Physical Layer TS 25.302
- | Synchronization in UTRAN Stage 2 TS 25.402

7.8 Performance/Test Specifications

- | UE Radio Transmission and Reception (FDD) TS 25.101
- | Common Test Environments for User Equipment (UE) TS 34.108
- | Special Conformance Testing Functions TS 34.109
- | Terminal Conformance Specification TS 34.121
- | User Equipment (UE) Conformance Specification; Part 1: Protocol Conformance TS 34.123-1
- | User Equipment (UE) Conformance Specification; Part 2: Protocol Conformance TS 34.123-2

7.9 SIM Specifications

- | SIM and IC Card Requirements TS 21.111
- | 3rd Gen. Partnership Proj Tech. Spec. Group Terminals; SIM App. Toolkit (USAT) TS 31.111

Acronyms and Abbreviations

3G	Third Generation
3GPP	3 rd Generation Partnership Project
AGPS	Assisted GPS
APN	Access Point Name
ARPU	Average Revenue Per User
BSS	Base Station Subsystem
CM	Connection Management
CPU	Central Processing Unit
CS domain	Circuit Switched domain
DTM	Digital Trunk Module
EDGE	Enhanced Data Rates for GSM Evolution
FDD	Frequency Division Duplex
GERAN	GSM/EDGE Radio Access Network
GPRS	General Packet Radio Service
GPS	Global Position System
GSM	Global System for Mobile Communications
HSDPA	High Speed Downlink Packet Access
HSPA	High Speed Packet Access
HSUPA	High Speed Uplink Packet Access
IC	Integrated Circuit
LCD	Liquid Crystal Display
LED	Light Emitting Diode
MAC	Medium Access Control
MexE	Mobile Execution Environment
MID	Mobile Internet Device
Mini PCI Express	Mini Peripheral Component Interconnect Express

MM	Mobility Management
Modem	Modulator Demodulator
MS	Mobile Station
MSC	Mobile Switching Center
NAS	Non-Access Stratum
NMEA	National Marine Electronics Association
OS	Operating System
OTA	Over The Air
PCM	Pulse Code Modulation
PIN	Personal Identification Number
PnP	Plug and Play
PP	Point-to-Point
PS domain	Packet Switched domain
PUK	PIN Unblocking Key
RF	Radio Frequency
RLC	Radio Link Control
RRC	Radio Resource Control
SGSN	Serving GPRS Support Node
SIM	Subscriber Identity Module
SMS	Short Messaging Service
SNDCP	Subnetwork Dependent Convergence Protocol
TIS	Total Isotropic Sensitivity
TR	Technical Report
TRP	Total Radiated Power
TS	Technical Specification
UE	User Equipment
UMTS	Universal Mobile Telecommunications System
USAT	USIM Application Toolkit
USB	Universal Serial Bus
USIM	UMTS Subscriber Identity Module
USSD	Unstructured Supplementary Service Data
UTRAN	UMTS Terrestrial Radio Access Network
WCDMA	Wideband Code Division Multiple Access



WWAN

Wireless Wide Area Network

PCIE CEM specification

PCI Express Mini Card Electromechanical Specification

HUAWEI Confidential

Safety Information

Read the safety information carefully to ensure the correct and safe use of your wireless device. Applicable safety information must be observed.

Interference

Power off your wireless device if using the device is prohibited. Do not use the wireless device when it causes danger or interference with electric devices.

Medical Device

- | Power off your wireless device and follow the rules and regulations set forth by the hospitals and health care facilities.
- | Some wireless devices may affect the performance of the hearing aids. For any such problems, consult your service provider.
- | Pacemaker manufacturers recommend that a minimum distance of 15 cm be maintained between the wireless device and a pacemaker to prevent potential interference with the pacemaker. If you are using an electronic medical device, consult the doctor or device manufacturer to confirm whether the radio wave affects the operation of this device.

Area with Inflammables and Explosives

To prevent explosions and fires in areas that are stored with inflammable and explosive devices, power off your wireless device and observe the rules. Areas stored with inflammables and explosives include but are not limited to the following:

- | Gas station
- | Fuel depot (such as the bunk below the deck of a ship)
- | Container/Vehicle for storing or transporting fuels or chemical products
- | Area where the air contains chemical substances and particles (such as granule, dust, or metal powder)
- | Area indicated with the "Explosives" sign
- | Area indicated with the "Power off bi-direction wireless equipment" sign
- | Area where you are generally suggested to stop the engine of a vehicle

Traffic Security

- | Observe local laws and regulations while using the wireless device. To prevent accidents, do not use your wireless device while driving.

- | RF signals may affect electronic systems of motor vehicles. For more information, consult the vehicle manufacturer.
- | In a motor vehicle, do not place the wireless device over the air bag or in the air bag deployment area. Otherwise, the wireless device may hurt you owing to the strong force when the air bag inflates.



Airline Security

Observe the rules and regulations of airline companies. When boarding or approaching a plane, power off your wireless device. Otherwise, the radio signal of the wireless device may interfere with the plane control signals.



Safety of Children

Do not allow children to use the wireless device without guidance. Small and sharp components of the wireless device may cause danger to children or cause suffocation if children swallow the components.

Environment Protection

Observe the local regulations regarding the disposal of your packaging materials, used wireless device and accessories, and promote their recycling.

WEEE Approval

The wireless device is in compliance with the essential requirements and other relevant provisions of the Waste Electrical and Electronic Equipment Directive 2002/96/EC (WEEE Directive).

RoHS Approval

The wireless device is in compliance with the restriction of the use of certain hazardous substances in electrical and electronic equipment Directive 2002/95/EC (RoHS Directive).



Laws and Regulations Observance

Observe laws and regulations when using your wireless device. Respect the privacy and legal rights of the others.



Care and Maintenance

It is normal that your wireless device gets hot when you use or charge it. Before you clean or maintain the wireless device, stop all applications and power off the wireless device.

- | Use your wireless device and accessories with care and in clean environment. Keep the wireless device from a fire or a lit cigarette.
- | Protect your wireless device and accessories from water and vapour and keep them dry.
- | Do not drop, throw or bend your wireless device.

- I Clean your wireless device with a piece of damp and soft antistatic cloth. Do not use any chemical agents (such as alcohol and benzene), chemical detergent, or powder to clean it.
- I Do not leave your wireless device and accessories in a place with a considerably low or high temperature.
- I Use only accessories of the wireless device approved by the manufacture. Contact the authorized service center for any abnormality of the wireless device or accessories.
- I Do not dismantle the wireless device or accessories. Otherwise, the wireless device and accessories are not covered by the warranty.

Emergency Call

This wireless device functions through receiving and transmitting radio signals. Therefore, the connection cannot be guaranteed in all conditions. In an emergency, you should not rely solely on the wireless device for essential communications.

Specific Absorption Rate (SAR)

Your wireless device is a radio transmitter and receiver. It is designed not to exceed the limits for exposure to radio waves recommended by international guidelines. These guidelines were developed by the independent scientific organization ICNIRP and include safety margins designed to assure the protection of all persons, regardless of age and health.

The guidelines use a unit of measurement known as the Specific Absorption Rate, or SAR. The SAR limit for wireless devices is 2.0 W/kg and the highest SAR value for this device when tested complied with this limit.

Regulatory Information

The following approvals and notices apply in specific regions as noted.

CE Approval (European Union)

The wireless device is approved to be used in the member states of the EU. The wireless device is in compliance with the essential requirements and other relevant provisions of the Radio and Telecommunications Terminal Equipment Directive 1999/5/EC (R&TTE Directive).

Federal Communications Commission Notice (United States): Before a wireless device model is available for sale to the public, it must be tested and certified to the FCC that it does not exceed the limit established by the government-adopted requirement for safe exposure.

The SAR limit adopted by the USA and Canada is 1.6 watts/kilogram (W/kg) averaged over one gram of tissue. The highest SAR value reported to the FCC for this device type was compliant with this limit.

FCC Statement

This device complies with Part 15 of the FCC Rules. Operation is subject to the following two conditions: (1) this device may not cause harmful interference, and (2) this device must accept any interference received, including interference that may cause undesired operation.

The antenna(s) used for this transmitter must be installed to provide a separation distance of at least 20 cm from all persons.

Warning: Changes or modifications made to this equipment not expressly approved by HUAWEI may void the FCC authorization to operate this equipment.

HUAWEI Confidential

