EM78P520N

**8-Bit Microprocessor
with OTP ROM**

**Product
Specification**

DOC. VERSION 1.4

ELAN MICROELECTRONICS CORP.

April 2016



Trademark Acknowledgments:

IBM is a registered trademark and PS/2 is a trademark of IBM.

Windows is a trademark of Microsoft Corporation

ELAN and ELAN logo  are trademarks of ELAN Microelectronics Corporation

Copyright © 2016 by **ELAN Microelectronics Corporation**

All Rights Reserved

Printed in Taiwan

The contents of this specification are subject to change without further notice. ELAN Microelectronics assumes no responsibility concerning the accuracy, adequacy, or completeness of this specification. ELAN Microelectronics makes no commitment to update, or to keep current the information and material contained in this specification. Such information and material may change to conform to each confirmed order.

In no event shall ELAN Microelectronics be made responsible for any claims attributed to errors, omissions, or other inaccuracies in the information or material contained in this specification. ELAN Microelectronics shall not be liable for direct, indirect, special incidental, or consequential damages arising from the use of such information or material.

The software (if any) described in this specification is furnished under a license or nondisclosure agreement, and may be used or copied only in accordance with the terms of such agreement.

ELAN Microelectronics products are not intended for use in life support appliances, devices, or systems. Use of ELAN Microelectronics product in such applications is not supported and is prohibited.

NO PART OF THIS SPECIFICATION MAY BE REPRODUCED OR TRANSMITTED IN ANY FORM OR BY ANY MEANS WITHOUT THE EXPRESSED WRITTEN PERMISSION OF ELAN MICROELECTRONICS.



ELAN MICROELECTRONICS CORPORATION

Headquarters:

No. 12, Innovation Road 1
Hsinchu Science Park
Hsinchu, TAIWAN 308
Tel: +886 3 563-9977
Fax: +886 3 563-9966
webmaster@emc.com.tw
<http://www.emc.com.tw>

Hong Kong:

Elan (HK) Microelectronics Corporation, Ltd.
Flat A, 19F., World Tech Centre
95 How Ming Street, Kwun Tong
Kowloon, HONG KONG
Tel: +852 2723-3376
Fax: +852 2723-7780

USA:

Elan Information Technology Group (U.S.A.)
PO Box 601
Cupertino, CA 95015
U.S.A.
Tel: +1 408 366-8225
Fax: +1 408 366-8225

Shenzhen:

Elan Microelectronics Shenzhen, Ltd.
8A Floor, Microprofit Building
Gaoxin South Road 6
Shenzhen Hi-tech Industrial Park
South Area, Shenzhen
CHINA 518057
Tel: +86 755 2601-0565
Fax: +86 755 2601-0500
elan-sz@elanic.com.cn

Shanghai:

Elan Microelectronics Shanghai, Ltd.
6F, Ke Yuan Building
No. 5 Bibo Road
Zhangjiang Hi-Tech Park
Shanghai, CHINA 201203
Tel: +86 21 5080-3866
Fax: +86 21 5080-0273
elan-sh@elanic.com.cn

Contents

1	General Description	1
2	Features	1
3	Pin Assignment	2
4	Pin Description	4
5	Block Diagram	9
6	Function Description.....	10
6.1	Register Configuration	10
6.1.1	R PAGE Register Configuration	10
6.2	Register Operations	10
6.2.1	R0 (Indirect Addressing Register)	10
6.2.2	R1 (TCC).....	10
6.2.3	R2 (Program Counter)	11
6.2.4	R3 (LVD Control and Status).....	12
6.2.5	R4 (RAM Select Register).....	13
6.2.6	Bank 0 R5 (RAM Bank Select Register)	13
6.2.7	Bank 0 R7 (Port 7)	13
6.2.8	Bank 0 R8 (Port 8)	13
6.2.9	Bank 0 R9 (Port 9)	14
6.2.10	Bank 0 RA (Port A)	14
6.2.11	Bank 0 RB (Port B)	14
6.2.12	Bank 0 RC SCCR (System Clock Control Register).....	14
6.2.13	Bank 0 RD TWTCR (TCC and WDT Timer Control Register)	15
6.2.14	Bank 0 RE IMR (Interrupt Mask Register)	16
6.2.15	Bank 0 RF ISR (Interrupt Status Register).....	16
6.2.16	Bank 1 R5 LCDCR (LCD Control Register)	17
6.2.17	Bank 1 R6 LCDAR (LCD Address Register).....	17
6.2.18	Bank 1 R7 LCDBR (LCD Data Buffer)	18
6.2.19	Bank 1 R8 LCDVCR (LCD Voltage Control Register).....	18
6.2.20	Bank 1 R9 LCDCCR (LCD COM Control Register 3)	19
6.2.21	Bank 1 RA LCDSCR0 (LCD Segment Control Register 0)	19
6.2.22	Bank 1 RB LCDSCR1 (LCD Segment Control Register 1).....	19
6.2.23	Bank 1 RC LCDSCR2 (LCD Segment Control Register 2)	20
6.2.24	Bank 1 RE EIMR (External Interrupt Mask Register).....	20
6.2.25	Bank 1 RF EISR (External Interrupt Status Register)	20
6.2.26	Bank 2 R5 T1CR (Timer 1 Control Register)	21
6.2.27	Bank 2 R6 TSR (Timer Status Register)	22
6.2.28	Bank 2 R7 T1PD (Timer 1 Period Buffer).....	23
6.2.29	Bank 2 R8 T1TD (Timer 1 Duty Buffer).....	23
6.2.30	Bank 2 R9 T2CR (Timer 2 Control Register)	23

6.2.31	Bank 2 RA T2PD (Timer 2 Period Buffer)	24
6.2.32	Bank 2 RB T2TD (Timer 2 Duty Buffer)	24
6.2.33	Bank 2 RC SPIS (SPI Status Register)	24
6.2.34	Bank 2 RD SPIC (SPI Control Register)	25
6.2.35	Bank 2 RE SPIR (SPI Read Buffer)	26
6.2.36	Bank 2 RF SPIW (SPI Write Buffer)	26
6.2.37	Bank 3 R5 URC (UART Control Register)	27
6.2.38	Bank 3 R6 URS (UART Status)	28
6.2.39	Bank 3 R7 URRD (UART_RD Data Buffer)	28
6.2.40	Bank 3 R8 URTD (UART_TD Data Buffer)	29
6.2.41	Bank 3 R9 ADCR (A/D Control Register)	29
6.2.42	Bank 3 RA ADICH (A/D Input Control Register)	30
6.2.43	Bank 3 RB ADICL (A/D Input Control Register)	30
6.2.44	Bank 3 RC ADDH (AD High 8-bit Data Buffer)	30
6.2.45	Bank 3 RD ADDL (AD Low 4-bit Data Buffer)	30
6.2.46	Bank 3 RE EIESH (External Interrupt Edge Select High Byte Control Register)	31
6.2.47	Bank 3 RF EIESL (External Interrupt Edge Select Low Byte Control Register)	31
6.2.48	Bank 4 R5 LEDDCR (LED Drive Control Register)	32
6.2.49	Bank 4 R6 WBCR (Watch Timer and Buzzer Control Register)	32
6.2.50	Bank 4 R7 P7IOCR (Port 7 I/O Control Register)	33
6.2.51	Bank 4 R8 P8IOCR (Port 8 I/O Control Register)	33
6.2.52	Bank 4 R9 P9IOCR (Port 9 I/O Control Register)	33
6.2.53	Bank 4 RA PAIOCR (Port A I/O Control Register)	33
6.2.54	Bank 4 RB PBIOCR (Port B I/O Control Register)	34
6.2.55	Bank 4 RC PCIOCR (Port C I/O Control Register)	34
6.2.56	Bank 4 RF WKCR (Wake-up Control Register)	34
6.2.57	Bank 5 R6 UARC2 (UART Control Register 2)	34
6.2.58	Bank 5 R7 P7PHCR (Port 7 Pull-high Control Register)	35
6.2.59	Bank 5 R8 P8PHCR (Port 8 Pull-high Control Register)	35
6.2.60	Bank 5 R9 P9PHCR (Port 9 Pull-high Control Register)	35
6.2.61	Bank 5 RA PAPHCR (Port A Pull-high Control Register)	35
6.2.62	Bank 5 RB PBPHCR (Port B Pull-high Control Register)	36
6.2.63	Bank 5 RC PCPHCR (Port C Pull High Control Register)	36
6.2.64	Bank 6 R6 LVRCR (Low Voltage Reset Control Register)	36
6.2.65	Bank 6 R7 P7ODCR (Port 7 Open Drain Control Register)	36
6.2.66	Bank 6 R8 P8ODCR (Port 8 Open Drain Control Register)	37
6.2.67	Bank 6 R9 P9ODCR (Port 9 Open Drain Control Register)	37
6.2.68	Bank 6 RA PAODCR (Port A Open Drain Control Register)	37
6.2.69	Bank 6 RB PBODCR (Port B Open Drain Control Register)	37
6.2.70	Bank 6 RC (Port C)	37
6.2.71	R10~R3F (General Purpose Register)	37

6.3	TCC/WDT Prescaler	38
6.4	I/O Port	39
6.5	Reset and Wake-up	40
6.6	Oscillator.....	50
6.6.1	Oscillator Modes	50
6.6.2	Crystal Oscillator/Ceramic Resonators (Crystal)	50
6.6.3	RC Oscillator Mode with Internal Capacitor	53
6.6.4	Phase Lock Loop (PLL Mode).....	53
6.7	Power-on Considerations.....	55
6.7.1	External Power-on Reset Circuit.....	55
6.7.2	Residue-Voltage Protection	56
6.8	Interrupt	57
6.9	LCD Driver.....	58
6.9.1	R5 LCDCR (LCD Control Register)	59
6.9.2	R6 LCDADDR (LCD Address Register)	60
6.9.3	R7 LCDBR (LCD Data Buffer)	61
6.9.4	R8 LCDVCR (LCD Voltage Control Register)	61
6.10	A/D Converter.....	69
6.10.1	ADC Data Register.....	70
6.10.2	A/D Sampling Time	70
6.10.3	A/D Conversion Time	70
6.11	UART (Universal Asynchronous Receiver/Transmitter)	71
6.11.1	UART Mode.....	72
6.11.2	Transmitting.....	73
6.11.3	Receiving	73
6.11.4	Baud Rate Generator	74
6.11.5	UART Timing.....	74
6.12	SPI (Serial Peripheral Interface)	75
6.12.1	Overview and Features	75
6.12.2	SPI Function Description	77
6.12.3	SPI Signal and Pin Description	78
6.12.4	Programming the Related Registers.....	80
6.12.5	SPI Mode Timing.....	83
6.13	Timer/Counter 1	84
6.13.1	Timer Mode	85
6.13.2	T1OUT Mode	85
6.13.3	Capture Mode	85
6.13.4	PWM Mode	86
6.13.5	16-Bit Mode.....	86

6.14	Timer 2	87
6.14.1	Timer Mode	88
6.14.2	PWM Mode	88
6.15	Code Options.....	89
6.16	Instruction Set.....	91
7	Absolute Maximum Ratings.....	94
8	DC Electrical Characteristics.....	94
8.1	DC Electrical Characteristics.....	94
8.2	A/D Converter Characteristics.....	96
8.3	Phase Lock Loop Characteristics.....	97
8.3.1	PLL DC Electrical Characteristics	97
8.3.2	AC Electrical Characteristics.....	97
8.4	Device Characteristics	97
9	AC Electrical Characteristics.....	106
10	Timing Diagrams	107

APPENDIX

A	Ordering and Manufacturing Information	108
B	Package Type.....	109
C	Package Information	110
C.1	EM78P520NQ44.....	110
C.2	EM78P520NL44	111
C.3	EM78P520NL48	112
D	Quality Assurance and Reliability	113
D.1	Address Trap Detect	113
E	EM78P520N Program Pin List.....	114
F	ICE 520 Oscillator Circuit (JP4)	114
F.1	Mode 1	114
F.2	Mode 2	115
F.3	Mode 3	115
F.4	Mode 4	115
F.5	Mode 5	116
F.6	Mode 6	116
F.7	Mode 7	116

Specification Revision History

Doc. Version	Revision Description	Date
1.0	Initial released version	2009/04/01
1.1	Modified the PLL mode that is used.	2011/03/23
1.2	Added LVR specifications	2013/04/09
1.3	Deleted the 32-pin Package Type	2014/02/05
1.4	<ol style="list-style-type: none">1. Added User Application Note2. Modified the package type in the Features section3. Modified Appendix A "Ordering and Manufacturing Information"	2016/04/08

User Application Note

(Before using this chip, take a look at the following description note, it includes important messages.)

1. The internal TCC will stop running when in sleep mode. However, during AD conversion, when TCC is set to “SLEP” instruction, if the ADWE bit of the RE register is enabled, the TCC will keep on running.
2. During ADC conversion, do not perform output instruction to maintain precision for all of the pins. In order to obtain accurate values, it is necessary to avoid any data transition on I/O pins during AD conversion
3. The noise rejection function is turned off in the LXT2 and sleep mode

1 General Description

The EM78P520N is an 8-bit RISC type microprocessor with low power, high speed CMOS technology. Integrated onto a single chip are on-chip Watchdog Timer (WDT), LCD Data RAM, ROM, programmable real time clock counter, internal/external interrupt, power down mode, 12 bits A/D Converter, UART, SPI, 8-channel LED driver, LCD driver and tri-state I/O.

2 Features

- CPU Configuration
 - 8K×13 bits on-chip ROM
 - 272×8 bits on-chip registers (SRAM)
 - 8-level stacks for subroutine nesting
 - Dual clock operation or PLL operation mode
 - Four operation mode: Normal, Green, Idle, Sleep
 - Less than 2.1 mA at 5V/4MHz
 - Typically 22 μ A, at 3V/32kHz
 - Typically 8 μ A, during sleep mode
 - Single Instruction Cycle Commands
 - I/O Port Configuration
 - Six bidirectional I/O ports : P7, P8, P9, PA, PB, PC
 - 43 I/O pins
 - 8-pin Direct Drive LED
 - 39 Programmable open-drain I/O pins
 - 43 programmable pull-high I/O pins
 - External interrupt : P74~P77, PB0~PB3, P82~P83
 - Operating voltage range:
OTP version:
 - Operating voltage range : 2.3V~5.5V
 - Operating temperature range : -40~85°C
 - Operating frequency range:
 - Crystal/RC oscillation circuit selected by code option for system clock
 - 32.768kHz crystal/RC oscillation circuit selected by code option for sub-oscillation
 - Main Clock
 - Crystal mode:
DC~20MHz/2 clks @ 5V; DC~100ns inst. cycle @ 5V
DC~8MHz/2 clks @ 3V; DC~250ns inst. Cycle @ 3V
DC~4MHz/2 clks @ 2.3V; DC~500ns inst. Cycle @ 2.3V
 - ERIC mode:
DC~2.2MHz/2 clks @ 2.3V; DC~909ns inst. cycle @ 2.3V
 - PLL mode:
DC~16MHz/2 clks @ 5V; DC~125ns inst Cycle @ 5V
 - Sub Clock
 - Crystal mode: 32.768kHz
 - ERIC mode: 33kHz (2.2M Ω)
 - Special Features
 - Programmable free running watchdog timer
 - High ESD immunity
 - High EFT immunity
 - Power saving Sleep mode
 - Selectable Oscillation mode
 - Peripheral Configuration
 - Serial peripheral interface (SPI) available
 - 8-bit real Time Clock/Counter (TCC)
 - 12-channels Analog-to-Digital Converter with 12-bit resolution in Vref mode
 - LCD: 8×23 dots, bias (1/2, 1/3, 1/4), duty (static, 1/3, 1/4, 1/8)
 - Two 8-bit timers
 - 8-bit Timer 1, auto reload counter/timer which can be an interrupt source. Function mode; Timer, Toggle output, UART baud rate generator, Capture, PWM
 - 8-bit Timer 2, auto reload timer which can be an interrupt source. Function mode; Timer, SPI baud rate generator, PWM
 - Two sets of 8-bit auto reload counter/timer which can be cascaded to one 16-bit counter/timer
 - Universal asynchronous receiver / transmitter (UART) available
 - Four programmable watch timer: 1.0 sec, 0.5 sec, 0.25sec, 3.91ms
 - Four programmable buzzer output: 0.5kHz, 1kHz, 2kHz, 4kHz
 - Four programmable Level Voltage Detector (LVD) : 3.9V, 3.3V, 2.7V, 2.4V
 - Power-on reset and three Programmable Level Voltage Reset POR: 2.1V (Default) LVR: 3.9V, 3.3V, 2.6V
 - Eighteen available interrupts:
 - TCC overflow interrupt
 - Ten External interrupts (wake-up from sleep mode)
 - ADC completion interrupt
 - Two timer interrupt
 - Watch timer interrupt
 - Two serial I/O interrupt
 - Low voltage detect (LVD)
 - Package Type:
 - 44 pin QFP 10×10mm : EM78P520NQ44
 - 44 pin LQFP 10×10mm : EM78P520NL44
 - 48 pin LQFP 7×7mm : EM78P520NL48
- Note:** *These are Green Products which do not contain hazardous substances.*

3 Pin Assignment

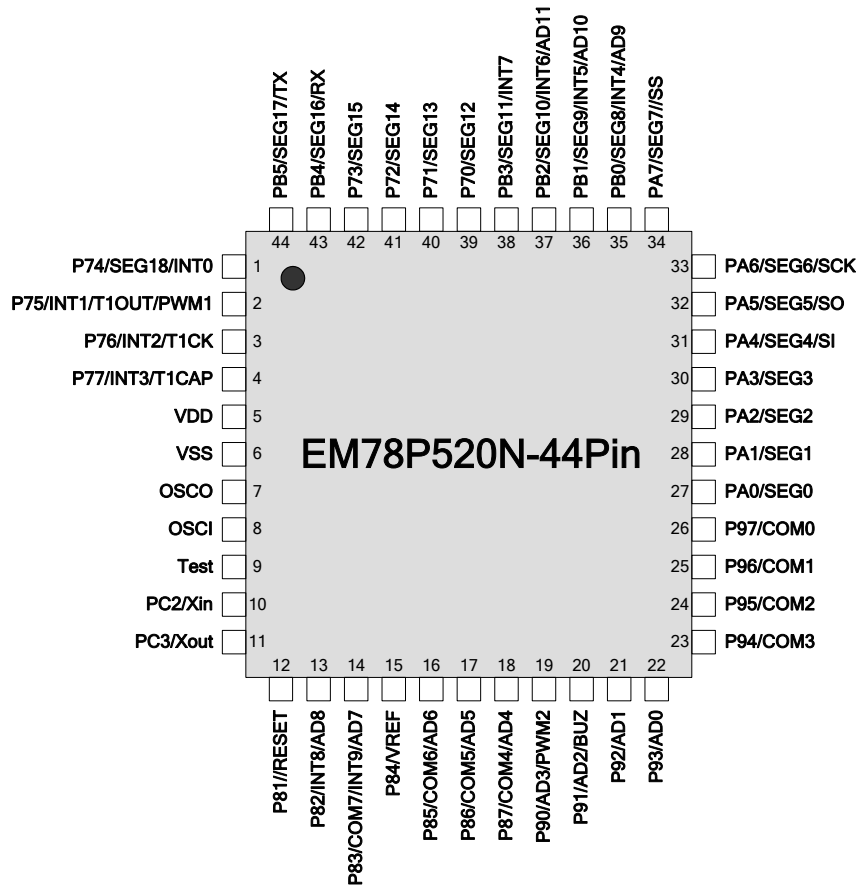

Figure 3-2 EM78P520NQ44/L44

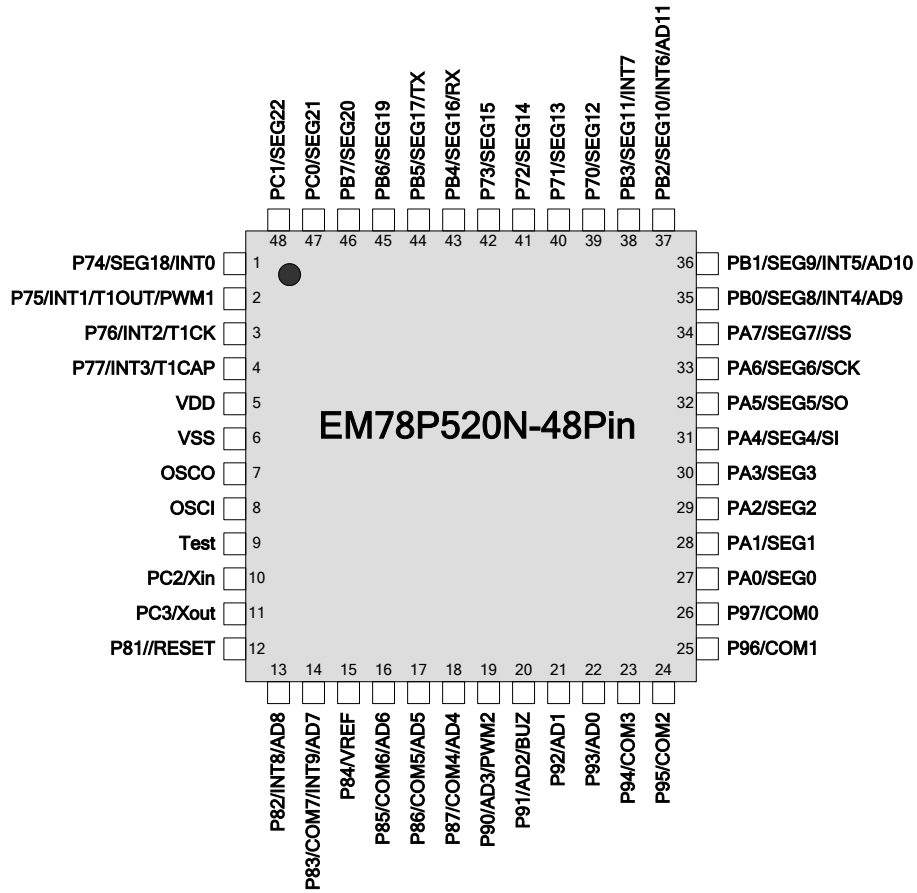

Figure 3-3 EM78P520NL48

4 Pin Description

Name	Function	Input Type	Output Type	Description
P70/SEG12	P70	ST	CMOS	Bidirectional I/O pin with programmable pull-high and open-drain.
	SEG12	-	AN	LCD Segment 12 output
P71/SEG13	P71	ST	CMOS	Bidirectional I/O pin with programmable pull-high and open-drain.
	SEG13	-	AN	LCD Segment 13 output
P72/SEG14	P72	ST	CMOS	Bidirectional I/O pin with programmable pull-high and open-drain.
	SEG14	-	AN	LCD Segment 14 output
P73/SEG15	P73	ST	CMOS	Bidirectional I/O pin with programmable pull-high and open-drain.
	SEG15	-	AN	LCD Segment 15 output
P74/SEG18/INT0	P74	ST	CMOS	Bidirectional I/O pin with programmable pull-high and open-drain.
	SEG18	-	AN	LCD Segment 18 output
	INT0	ST	-	External interrupt pin
P75/INT1/T1OUT/PWM1	P75	ST	CMOS	Bidirectional I/O pin with programmable pull-high and open-drain.
	INT1	ST	-	External interrupt pin
	T1OUT	-	CMOS	Timer 1 T1OUT mode
	PWM1	-	CMOS	Timer 1 PWM mode
P76/INT2/T1CK	P76	ST	CMOS	Bidirectional I/O pin with programmable pull-high and open-drain.
	INT2	ST	-	External interrupt pin
	T1CK	ST	-	Timer 1 Counter mode
P77/INT3/T1CAP	P77	ST	CMOS	Bidirectional I/O pin with programmable pull-high and open-drain.
	INT3	ST	-	External Interrupt pin
	T1CAP	ST	-	Timer 1 Capture mode
P81/ /RESET	P81	ST	CMOS	Bidirectional I/O pin with programmable pull-high and open-drain.
	/RESET	ST	-	Internal pull-high (set P57 pull-high) reset pin
P82/INT8/AD8	P82	ST	CMOS	Bidirectional I/O pin with programmable pull-high and open-drain.
	INT8	ST	-	External interrupt pin
	AD8	AN	-	ADC Input 8



(Continuation)

Name	Function	Input Type	Output Type	Description
P83/COM7/INT9/AD7	P83	ST	CMOS	Bidirectional I/O pin with programmable pull-high and open-drain.
	COM7	-	AN	LCD Common 7 output
	INT9	ST	-	External interrupt pin
	AD7	AN	-	ADC Input 7
P84/VREF	P84	ST	CMOS	Bidirectional I/O pin with programmable pull-high and open-drain.
	VREF	AN	-	Voltage reference for ADC
P85/COM6/AD6	P85	ST	CMOS	Bidirectional I/O pin with programmable pull-high and open-drain.
	COM6	-	AN	LCD Common 6 output
	AD6	AN	-	ADC Input 6
P86/COM5/AD5	P86	ST	CMOS	Bidirectional I/O pin with programmable pull-high and open-drain.
	COM5	-	AN	LCD Common 5 output
	AD5	AN	-	ADC Input 5
P87/COM4/AD4	P87	ST	CMOS	Bidirectional I/O pin with programmable pull-high and open-drain.
	COM4	-	AN	LCD Common 4 output
	AD4	AN	-	ADC Input 4
P90/AD3/PWM2	P90	ST	CMOS	Bidirectional I/O pin with programmable pull-high, open-drain and LED drive.
	AD3	AN	-	ADC Input 3
	PWM2	-	CMOS	Timer 2 PWM mode
P91/AD2/BUZ	P91	ST	CMOS	Bidirectional I/O pin with programmable pull-high, open-drain and LED drive.
	AD2	AN	-	ADC Input 2
	BUZ	-	CMOS	Buzzer Timer output
P92/AD1	P92	ST	CMOS	Bidirectional I/O pin with programmable pull-high, open-drain and LED drive.
	AD1	AN	-	ADC Input 1
P93/AD0	P93	ST	CMOS	Bidirectional I/O pin with programmable pull-high, open-drain and LED drive.
	AD0	AN	-	ADC Input 0
P94/COM3	P94	ST	CMOS	Bidirectional I/O pin with programmable pull-high, open-drain and LED drive.
	COM3	-	AN	LCD Common 3 output

(Continuation)

Name	Function	Input Type	Output Type	Description
P95/COM2	P95	ST	CMOS	Bidirectional I/O pin with programmable pull-high, open-drain and LED drive.
	COM2	-	AN	LCD Common 2 output
P96/COM1	P96	ST	CMOS	Bidirectional I/O pin with programmable pull-high, open-drain and LED drive.
	COM1	-	AN	LCD Common 1 output
P97/COM0	P97	ST	CMOS	Bidirectional I/O pin with programmable pull-high, open-drain and LED drive.
	COM0	-	AN	LCD Common 0 output
PA0/SEG0	PA0	ST	CMOS	Bidirectional I/O pin with programmable pull-high and open-drain.
	SEG0	-	AN	LCD Segment 0 output
PA1/SEG1	PA1	ST	CMOS	Bidirectional I/O pin with programmable pull-high and open-drain.
	SEG1	-	AN	LCD Segment 1 output
PA2/SEG2	PA2	ST	CMOS	Bidirectional I/O pin with programmable pull-high and open-drain.
	SEG2	-	AN	LCD Segment 2 output
PA3/SEG3	PA3	ST	CMOS	Bidirectional I/O pin with programmable pull-high and open-drain.
	SEG3	-	AN	LCD Segment 3 output
PA4/SEG4/SI	PA4	ST	CMOS	Bidirectional I/O pin with programmable pull-high and open-drain.
	SEG4	-	AN	LCD Segment 4 output
	SI	ST	-	SPI serial data input
PA5/SEG5/SO	PA5	ST	CMOS	Bidirectional I/O pin with programmable pull-high and open-drain.
	SEG5	-	AN	LCD Segment 5 output
	SO	-	CMOS	SPI serial data output
PA6/SEG6/SCK	PA6	ST	CMOS	Bidirectional I/O pin with programmable pull-high and open-drain.
	SEG6	-	AN	LCD Segment 6 output
	SCK	ST	CMOS	SPI serial clock input/output
PA7/SEG7//SS	PA7	ST	CMOS	Bidirectional I/O pin with programmable pull-high and open-drain.
	SEG7	-	AN	LCD Segment 7 output
	/SS	ST	-	SPI Slave select pin

(Continuation)

Name	Function	Input Type	Output Type	Description
PB0/SEG8/INT4/ AD9	PB0	ST	CMOS	Bidirectional I/O pin with programmable pull-high and open-drain.
	SEG8	-	AN	LCD Segment 8 output
	INT4	ST	-	External interrupt pin
	AD9	AN	-	ADC Input 9
PB1/SEG9/INT5/ AD10	PB1	ST	CMOS	Bidirectional I/O pin with programmable pull-high and open-drain.
	SEG9	-	AN	LCD Segment 9 output
	INT5	ST	-	External interrupt pin
	AD10	AN	-	ADC Input 10
PB2/SEG10/INT6/ AD11	PB2	ST	CMOS	Bidirectional I/O pin with programmable pull-high and open-drain.
	SEG10	-	AN	LCD Segment 10 output
	INT6	ST	-	External interrupt pin
	AD11	AN	-	ADC Input 11
PB3/SEG11/INT7	PB3	ST	CMOS	Bidirectional I/O pin with programmable pull-high and open-drain.
	SEG11	-	AN	LCD Segment 11 output
	INT7	ST	-	External interrupt pin
PB4/SEG16/RX	PB4	ST	CMOS	Bidirectional I/O pin with programmable pull-high and open-drain.
	SEG16	-	AN	LCD Segment 16 output
	RX	ST	-	UART RX input

(Continuation)

Name	Function	Input Type	Output Type	Description
PB5/SEG17/TX	PB5	ST	CMOS	Bidirectional I/O pin with programmable pull-high and open-drain.
	SEG17	-	AN	LCD Segment 17 output
	TX	-	CMOS	UART TX output
PB6/SEG19	PB6	ST	CMOS	Bidirectional I/O pin with programmable pull-high and open-drain.
	SEG19	-	AN	LCD Segment 19 output
PB7/SEG20	PB7	ST	CMOS	Bidirectional I/O pin with programmable pull-high and open-drain.
	SEG20	-	AN	LCD Segment 20 output
PC0/SEG21	PC0	ST	CMOS	Bidirectional I/O pin with programmable pull-high.
	SEG21	-	AN	LCD Segment 21 output
PC1/SEG22	PC1	ST	CMOS	Bidirectional I/O pin with programmable pull-high.
	SEG22	-	AN	LCD Segment 22 output
PC2/Xin	PC2	ST	CMOS	Bidirectional I/O pin with programmable pull-high.
	Xin	XTAL	-	Clock input of crystal/resonator oscillator only for 32.768kHz
PC3/Xout	PC3	ST	CMOS	Bidirectional I/O pin with programmable pull-high.
	Xout	-	XTAL	Clock output of crystal/resonator oscillator only for 32.768kHz
OSCO	OSCO	-	XTAL	Clock output of crystal/resonator oscillator
OSCI	OSCI	XTAL	-	Clock input of crystal/resonator oscillator
VDD	VDD	Power	-	Power
VSS	VSS	Power	-	Ground
Test	Test	Power	-	Test signal import pin (must be connected to VDD)

Legend: ST : Schmitt Trigger input

AN : Analog pin

XTAL : Oscillation pin for crystal/resonator

CMOS : CMOS output



6 Function Description

6.1 Register Configuration

6.1.1 R PAGE Register Configuration

Bank 0	Bank 1	Bank 2	Bank 3	Bank 4	Bank 5	Bank 6
R0 (IAR)						
R1 (TCC)						
R2 (PC)						
R3 (SR)						
R4 (RSR)						
RBSR	LCDCR	T1CR	URC	LEDDCR	Reserve	Reserve
Reserve	LCDAR	TSR	URS	WBCR	URC2	LVR CR
Port 7	LCDBR	T1PD	URRD	IOC7	P7PHCR	P7ODCR
Port 8	LCDVCR	T1TD	URTD	IOC8	P8PHCR	P8ODCR
Port 9	LCDCR	T2CR	ADCR	IOC9	P9PHCR	P9ODCR
Port A	LCDSCR0	T2PD	ADICH	IOCA	PAPHCR	PAODCR
Port B	LCDSCR1	T2TD	ADICL	IOCB	PBPHCR	PBODCR
SCCR	LCDSCR2	SPIS	ADDH	IOCC	PCPHCR	Port C
TWTCR	Reserve	SPIC	ADDL	Reserve	Reserve	Reserve
IMR	EIMR	SPIR	EIESH	Reserve	Reserve	Reserve
ISR	EISR	SPIW	EIESL	WKCR	Reserve	Reserve
R10						
.						
.						
R1F						
R20	Bank 1 Bank 7					
	General Purpose RAM		R20			
.	.	.	.			
.	.	.	.			
.	.	.	.			
R3F	.	.	R3F			

Figure 6-1 Data Memory Configuration

6.2 Register Operations

6.2.1 R0 (Indirect Addressing Register)

R0 is not a physically implemented register. It is used as an indirect addressing pointer. Any instruction using R0 as register actually accesses data pointed by the RAM Select Register (R4).

6.2.2 R1 (TCC)

R1 is incremented by the main oscillator clock (Fm) or sub oscillator clock (Fs) (controlled by TWTCR register). It is written and read by the program as any other register.

6.2.3 R2 (Program Counter)

The structure is depicted in Figure 6-2. Generates $8K \times 13$ on-chip ROM addresses to the relative programming instruction codes.

"JMP" instruction allows the direct loading of the low 10 program counter bits.

"CALL" instruction loads the low 10 bits of the PC and PC+1, and push onto the stack.

"RET" ("RETL k", "RETI") instruction loads the program counter with the contents at the top of the stack level.

"MOV R2, A" allows the loading of an address from the A register to the PC, and contents of the ninth and tenth bits remain unchanged.

"ADD R2, A" allows a relative address to be added to the current PC, and the contents of the ninth and tenth bits remain unchanged.

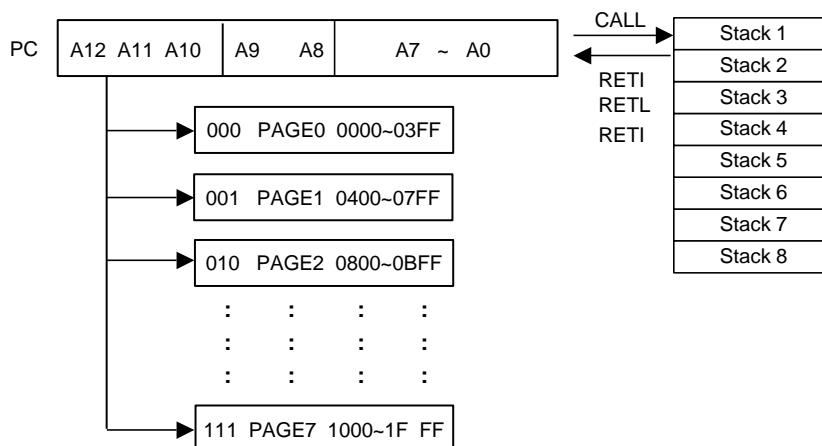

Figure 6-2 Program Counter Organization

User can use the Long jump (LJMP) or long call (LCALL) instructions to program user's code. And the program page is maintained by ELAN's compiler. It will change the user's program by inserting instructions within the program.

6.2.4 R3 (LVD Control and Status)

■ Status Flag, Page Select Bits

Bit 7	Bit 6	Bit 5	Bit 4	Bit 3	Bit 2	Bit 1	Bit 0
LV DEN	LV DS1	LV DS0	T	P	Z	DC	C

Bit 7 (LV DEN): Voltage Detect Enable Bit

0 : No action

1 : Voltage detect enabled

Bits 6~5 (LV DS1~LV DS0): Detect Voltage Select Bits

LV DS1	LV DS0	Detect Voltage
0	0	2.4V
0	1	2.7V
1	0	3.3V
1	1	3.9V

Bit 4 (T): Time-out bit

Set to "1" by the "SLEP" and "WDTC" commands, or during power up and reset to "0" by WDT timeout.

Bit 3 (P): Power down bit

Set to "1" during power-on or by a "WDTC" command and reset to "0" by a "SLEP" command.

Event	T	P	Remarks
WDT wakes up from sleep mode	0	0	–
WDT time out (not in sleep mode)	0	1	–
/RESET wakes up from sleep	1	0	–
Power up	1	1	–
Low pulse on /RESET	×	×	× = don't care

Bit 2 (Z): Zero flag

Bit 1 (DC): Auxiliary carry flag

Bit 0 (C): Carry flag

6.2.5 R4 (RAM Select Register)

Bit 7 (VDB): Voltage Detector. This is a read only bit. When VDD pin voltage is lower than Vdet (select by LVDS0~LVDS1) this bit will be cleared.

0 : low voltage is detected

1 : low voltage is not detected or LVD function is disabled

Bit 6 (BNC): Bank Control Register

0 : allow to access only Bank 0 registers

1 : Allow to access all registers of any Bank

Bits 5~0: are used to select up to 64 registers in the indirect addressing mode.

See the the data memory configuration. User can use BANK instruction to change bank.

6.2.6 Bank 0 R5 (RAM Bank Select Register)

Bit 7	Bit 6	Bit 5	Bit 4	Bit 3	Bit 2	Bit 1	Bit 0
0	0	0	0	0	BS2	BS1	BS0

Bits 7~3: Reserved

Bits 2~0 (BS2~BS0): RAM Bank Select Register

BS2	BS1	BS0	RAM Bank
0	0	0	Bank 0
0	0	1	Bank 1
:	:	:	:
:	:	:	:
1	1	1	Bank 7

6.2.7 Bank 0 R7 (Port 7)

Bit 7	Bit 6	Bit 5	Bit 4	Bit 3	Bit 2	Bit 1	Bit 0
R77	R76	R75	R74	R73	R72	R71	R70

Bits 7~0 (R77~R70): 8-bit I/O Registers of Port 7.

6.2.8 Bank 0 R8 (Port 8)

Bit 7	Bit 6	Bit 5	Bit 4	Bit 3	Bit 2	Bit 1	Bit 0
R87	R86	R85	R84	R83	R82	R81	0

Bits 7~1 (R87~R81): 7-bit I/O Registers of Port 8.

Bit 0: Reserved

6.2.9 Bank 0 R9 (Port 9)

Bit 7	Bit 6	Bit 5	Bit 4	Bit 3	Bit 2	Bit 1	Bit 0
R97	R96	R95	R94	R93	R92	R91	R90

Bits 7~0 (R97~R90): Port 9 8-bit I/O Registers.

6.2.10 Bank 0 RA (Port A)

Bit 7	Bit 6	Bit 5	Bit 4	Bit 3	Bit 2	Bit 1	Bit 0
RA7	RA6	RA5	RA4	RA3	RA2	RA1	RA0

Bits 7~0 (RA7~RA0): Port A 8-bit I/O Registers

6.2.11 Bank 0 RB (Port B)

Bit 7	Bit 6	Bit 5	Bit 4	Bit 3	Bit 2	Bit 1	Bit 0
RB7	RB6	RB5	RB4	RB3	RB2	RB1	RB0

Bits 7~0 (RB7~RB0): Port B 8-bit I/O Registers

6.2.12 Bank 0 RC SCCR (System Clock Control Register)

Bit 7	Bit 6	Bit 5	Bit 4	Bit 3	Bit 2	Bit 1	Bit 0
0	CLK2	CLK1	CLK0	IDLE	0	0	CPUS

Bit 7: Reserved, fixed to "0"

Bits 6~4 (CLK2~CLK0): Main Clock Select Bit for PLL Mode (code option select)

CLK2	CLK1	CLK0	Main Clock	Example Fs = 32.768kHz
0	X	X	Reserved	-
1	0	X	Reserved	-
1	1	X	Fs×488	15.99 MHz

Bit 3 (IDLE): Idle Mode Enable Bit. This bit will determine as to which mode to activate after SLEP instruction.

IDLE="0"+SLEP instruction → sleep mode

IDLE="1"+SLEP instruction → idle mode

Bits 2~1: Reserved, fixed to "0"

Bit 0 (CPUS): CPU Oscillator Source Select

0 : → sub-oscillator (fs)

1 : → main oscillator (fosc)

When CPUS=0, the CPU oscillator selects the sub-oscillator and the main oscillator is stopped.

CPU Operation Mode

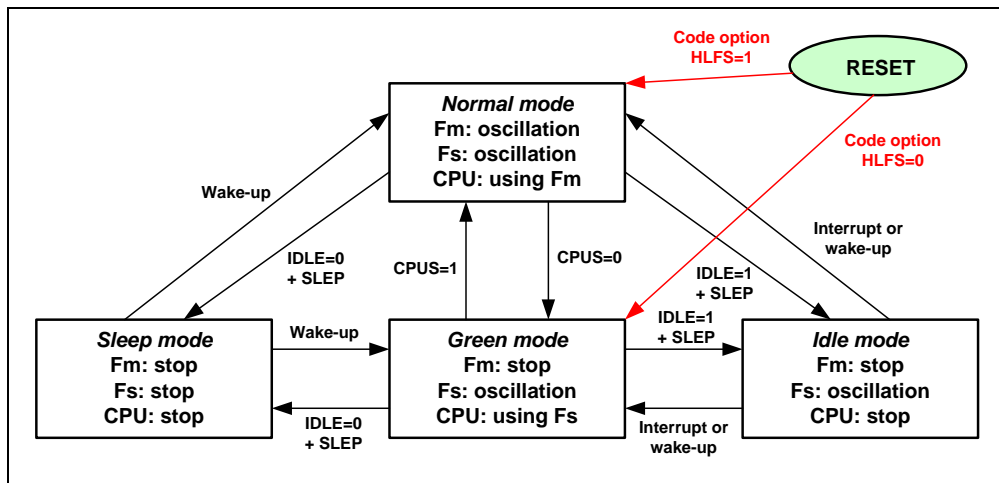

Figure 6-3 CPU Operation Mode

6.2.13 Bank 0 RD TWTCR (TCC and WDT Timer Control Register)

Bit 7	Bit 6	Bit 5	Bit 4	Bit 3	Bit 2	Bit 1	Bit 0
WDTE	WPSR2	WPSR1	WPSR0	TCCS	TPSR2	TPSR1	TPSR0

Bit 7 (WDTE): Watchdog Timer Enable. This control bit is used to enable the watchdog timer.

0 : Disable WDT function

1 : Enable WDT function

Bits 6~4 (WPSR2~WPSR0): WDT Prescaler Bits

WPSR2	WPSR1	WPSR0	Prescaler
0	0	0	1:1 (Default)
0	0	1	1 : 2
0	1	0	1 : 4
0	1	1	1 : 8
1	0	0	1 : 16
1	0	1	1 : 32
1	1	0	1 : 64
1	1	1	1 : 128

Bit 3 (TCCS): TCC Clock Source Select Bit

0 : Fm (main clock)

1 : Fs (sub clock: 32.768kHz)

Bits 2~0 (TPSR2~TPSR0): TCC Prescaler Bits

TPSR2	TPSR1	TPSR0	Prescaler
0	0	0	1:2 (Default)
0	0	1	1 : 4
0	1	0	1 : 8
0	1	1	1 : 16
1	0	0	1 : 32
1	0	1	1 : 64
1	1	0	1 : 128
1	1	1	1 : 256

6.2.14 Bank 0 RE IMR (Interrupt Mask Register)

Bit 7	Bit 6	Bit 5	Bit 4	Bit 3	Bit 2	Bit 1	Bit 0
T1IE	LVDIE	ADIE	SPIIE	URTIE	EXIE9	EXIE8	TCIE

Bits 7~0 (T1IE~TCIE): Interrupt Enable Bit. Enable the interrupt source.

0 : Disable interrupt

1 : Enable interrupt

External Interrupt

INT Pin	Secondary Function Pin	Enable Condition	Edge	Digital Noise Reject
INT8	P82, AD8	ENI+EXIE8 (IMR1)	Rising or Falling	2/Fc
INT9	P83, COM7, AD7	ENI+EXIE9 (IMR2)	Rising or Falling	2/Fc

INT8~INT9: Pulse less than 2/Fc is eliminated as noise. Pulse more than 4/Fc is treated as a trigger signal.

6.2.15 Bank 0 RF ISR (Interrupt Status Register)

Bit 7	Bit 6	Bit 5	Bit 4	Bit 3	Bit 2	Bit 1	Bit 0
T1IF	LVDIF	ADIF	SPIIF	URTIF	EXIF9	EXIF8	TCIF

These bits are set to "1" when interrupt occurs.

Bit 7 (T1IF): Interrupt Flag of Timer 1 Interrupt

Bit 6 (LVDIF): Interrupt Flag of Low Voltage Detector Interrupt

Bit 5 (ADIF): Interrupt Flag of A/D Conversion Completed

Bit 4 (SPIIF): Interrupt Flag of SPI Transfer Completed

Bit 3 (URTIF): Interrupt Flag of UART Transfer Completed

Bit 2 (EXIF9): Interrupt Flag of External Interrupt 9 occurs

Bit 1 (EXIF8): Interrupt Flag of External Interrupt 8 occurs

Bit 0 (TCIF): Interrupt Flag of TCC overflow

6.2.16 Bank 1 R5 LCDCR (LCD Control Register)

Bit 7	Bit 6	Bit 5	Bit 4	Bit 3	Bit 2	Bit 1	Bit 0
LCDEN	LCDTYPE	BS1	BS0	DS1	DS0	LCDF1	LCDF0

Bit 7 (LCDEN): LCD Enable Select Bit

- 0 : LCD disabled. All common/segment outputs are set to VDD level.
- 1 : LCD enabled

Bit 6 (LCDTYPE): LCD Drive Waveform Type Select Bit

- 0 : A type wave
- 1 : B type wave

Bits 5~4 (BS1~BS0): LCD Bias Select Bits

BS1	BS0	LCD Bias Select
0	0	1/2 Bias
0	1	1/3 Bias
1	×	1/4 Bias

Bits 3~2 (DS1~DS0): LCD Duty Select Bits

DS1	DS0	LCD Duty
0	0	Static
0	1	1/3 Duty
1	0	1/4 Duty
1	1	1/8 Duty

Bits 1~0 (LCDF1~LCDF0): LCD Frame Frequency Control Bits

LCD Frame Frequency (e.g. $F_s=32.768K$)					
LCDF1	LCDF0	Static	1/3 Duty	1/4 Duty	1/8 Duty
0	0	$F_s/(512 \times 1) = 64.0$	$F_s/(172 \times 3) = 63.5$	$F_s/(128 \times 4) = 64$	$F_s/(64 \times 8) = 64.0$
0	1	$F_s/(560 \times 1) = 58.5$	$F_s/(188 \times 3) = 58$	$F_s/(140 \times 4) = 58.5$	$F_s/(70 \times 8) = 58.5$
1	0	$F_s/(608 \times 1) = 53.9$	$F_s/(204 \times 3) = 53.5$	$F_s/(152 \times 4) = 53.9$	$F_s/(76 \times 8) = 53.9$
1	1	$F_s/(464 \times 1) = 70.6$	$F_s/(156 \times 3) = 70$	$F_s/(116 \times 4) = 70.6$	$F_s/(58 \times 8) = 70.6$

6.2.17 Bank 1 R6 LCDAR (LCD Address Register)

Bit 7	Bit 6	Bit 5	Bit 4	Bit 3	Bit 2	Bit 1	Bit 0
0	0	0	LCD_A4	LCD_A3	LCD_A2	LCD_A1	LCD_A0

Bits 7~5: Reserved

Bits 4~0 (LCD_A4~LCD_A0): LCD RAM Address

R6 (LCD Address)	R7 (LCD Data Buffer)								Segment
	Bit 7 (LCD_D7)	Bit 6 (LCD_D6)	Bit 5 (LCD_D5)	Bit 4 (LCD_D4)	Bit 3 (LCD_D3)	Bit 2 (LCD_D2)	Bit 1 (LCD_D1)	Bit 0 (LCD_D0)	
00H									SEG0
01H									SEG1
02H									SEG2
14H									SEG20
15H									SEG21
16H									SEG22
Common	COM7	COM6	COM5	COM4	COM3	COM2	COM1	COM0	

6.2.18 Bank 1 R7 LCDBR (LCD Data Buffer)

Bit 7	Bit 6	Bit 5	Bit 4	Bit 3	Bit 2	Bit 1	Bit 0
LCD_D7	LCD_D6	LCD_D5	LCD_D4	LCD_D3	LCD_D2	LCD_D1	LCD_D0

Bits 7~0 (LCD_D7~LCD_D0): LCD RAM Data Transfer Register

6.2.19 Bank 1 R8 LCDVCR (LCD Voltage Control Register)

Bit 7	Bit 6	Bit 5	Bit 4	Bit 3	Bit 2	Bit 1	Bit 0
0	0	0	LCDC1	LCDC0	LCDVC2	LCDVC1	LCDVC0

Bits 7~5: Reserved

Bits 4~3 (LCDC1~LCDC0): LCD Clock

LCDC1	LCDC0	F _m	F _{LCD}
0	0	16M	F _c /2 ⁹
0	1	8M	F _c /2 ⁸
1	0	4M	F _c /2 ⁷
1	1	2M	F _c /2 ⁶

When the main oscillator operates in crystal mode and the sub-oscillator does not, it is a must to set these two bits for the LCD clock.

Bits 2~0 (LCDVC2~LCDVC0): LCD Voltage Control Bits

LCDVC2	LCDVC1	LCDVC0	Output
0	0	0	0.4VDD ~ VDD
0	0	1	0.34VDD ~ VDD
0	1	0	0.26VDD ~ VDD
0	1	1	0.18VDD ~ VDD
1	0	0	0.13VDD ~ VDD
1	0	1	0.07VDD ~ VDD
1	1	0	0.04VDD ~ VDD
1	1	1	0V ~ VDD

6.2.20 Bank 1 R9 LCDCCR (LCD COM Control Register 3)

Bit 7	Bit 6	Bit 5	Bit 4	Bit 3	Bit 2	Bit 1	Bit 0
COM7	COM6	COM5	COM4	COM3	COM2	COM1	COM0

Bits 7~0 (COM7~COM0): LCD Com 7~0 Control Bits

- 0 : Disable, functions as normal I/O or other functions
- 1 : Enable, functions as LCD common driver pins

6.2.21 Bank 1 RA LCDSCR0 (LCD Segment Control Register 0)

Bit 7	Bit 6	Bit 5	Bit 4	Bit 3	Bit 2	Bit 1	Bit 0
SEG7	SEG6	SEG5	SEG4	SEG3	SEG2	SEG1	SEG0

Bits 7~0 (SEG7~SEG0): LCD Segments 7~0 Control Bits

- 0 : Disable, functions as normal I/O or other functions
- 1 : Enable, functions as LCD common driver pins

6.2.22 Bank 1 RB LCDSCR1 (LCD Segment Control Register 1)

Bit 7	Bit 6	Bit 5	Bit 4	Bit 3	Bit 2	Bit 1	Bit 0
SEG15	SEG14	SEG13	SEG12	SEG11	SEG10	SEG9	SEG8

Bits 7~0 (SEG15~SEG8): LCD Segments 15~8 Control Bits

- 0 : Disable, functions as normal I/O or other functions
- 1 : Enable, functions as LCD common driver pins

6.2.23 Bank 1 RC LCDSCR2 (LCD Segment Control Register 2)

Bit 7	Bit 6	Bit 5	Bit 4	Bit 3	Bit 2	Bit 1	Bit 0
-	SEG22	SEG21	SEG20	SEG19	SEG18	SEG17	SEG16

Bit 7: Reserved

Bits 6~0 (SEG22~SEG16): LCD Segment 22~16 Control Bits

0 : Disable, functions as normal I/O or other functions

1 : Enable, functions as LCD common driver pins

6.2.24 Bank 1 RE EIMR (External Interrupt Mask Register)

Bit 7	Bit 6	Bit 5	Bit 4	Bit 3	Bit 2	Bit 1	Bit 0
EXIE7	EXIE6	EXIE5	EXIE4	EXIE3	EXIE2	EXIE1	EXIE0

Bits 7~0 (EXIE7~EXIE0): Interrupt Enable Bit. Enable interrupt source respectively.

External interrupt

INT Pin	Secondary Function Pin	Enable Condition	Edge	Digital Noise Reject
INT7	PB3, SEG11	ENI+EXIE7 (EIMR7)	Rising or Falling	2/Fc
INT6	PB2, SEG10, AD11	ENI+EXIE6 (EIMR6)	Rising or Falling	2/Fc
INT5	PB1, SEG9, AD10	ENI+EXIE5 (EIMR5)	Rising or Falling	2/Fc
INT4	PB0, SEG8, AD9	ENI+EXIE4 (EIMR4)	Rising or Falling	2/Fc
INT3	P77, T1CAP	ENI+EXIE3 (EIMR3)	Rising or Falling	2/Fc
INT2	P76, T1CK	ENI+EXIE2 (EIMR2)	Rising or Falling	2/Fc
INT1	P75, T1OUT, PWM1	ENI+EXIE1 (EIMR1)	Rising or Falling	2/Fc
INT0	P74, SEG18	ENI+EXIE0 (EIMR0)	Rising or Falling	2/Fc

INT7~INT0: Pulse less than 2/Fc is eliminated as noise. Pulse more than 4/Fc is treated as a trigger signal.

6.2.25 Bank 1 RF EISR (External Interrupt Status Register)

Bit 7	Bit 6	Bit 5	Bit 4	Bit 3	Bit 2	Bit 1	Bit 0
EXIF7	EXIF6	EXIF5	EXIF4	EXIF3	EXIF2	EXIF1	EXIF0

These bits are set to "1" when interrupt occurs.

Bits 7~0 (EXIF7~EXIF0): Interrupt Flag when External Interrupt 7~0 occur

6.2.26 Bank 2 R5 T1CR (Timer 1 Control Register)

Bit 7	Bit 6	Bit 5	Bit 4	Bit 3	Bit 2	Bit 1	Bit 0
TIS1	TIS0	T1MS2	T1MS1	T1MS0	T1P2	T1P1	T1P0

Bits 7~6 (TIS1~ TIS0): Timer 1 and Timer 2 Interrupt Type Select Bits. These two bits are used when the Timer operates in PWM mode.

TIS1	TIS0	Timer 1 and Timer 2 Interrupt Type Select
0	0	TXPD underflow
0	1	TXTD underflow
1	×	TXPD and TXTD underflow

Bits 5~3 (T1MS2~T1MS0): Timer 1 Operation Mode Select Bits

T1MS2	T1MS1	T1MS0	Timer 1 Mode Select
0	0	0	Timer 1
0	0	1	T1OUT Mode
0	1	0	Capture Mode Rising Edge
0	1	1	Capture Mode Falling Edge
1	0	0	UART Baud Rate Generator
1	0	1	PWM 1
1	1	0	
1	1	1	

Bits 2~0 (T1P2~T1P0): Timer 1 Prescaler Bits

T1P2	T1P1	T1P0	Prescaler
0	0	0	1:2 (Default)
0	0	1	1 : 4
0	1	0	1 : 8
0	1	1	1 : 16
1	0	0	1 : 32
1	0	1	1 : 64
1	1	0	1 : 128
1	1	1	1 : 256

6.2.27 Bank 2 R6 TSR (Timer Status Register)

Bit 7	Bit 6	Bit 5	Bit 4	Bit 3	Bit 2	Bit 1	Bit 0
T1MOD	TRCB	T1CSS1	T1CSS0	T2CSS	T1S	T1OMS	T1OC

Bit 7 (T1MOD): Timer Operation Mode Select Bit

- 0 : Two 8-bit Timers
- 1 : Timer 1 and Timer 2 cascaded to one 16-bit Timer

NOTE

By setting T1MOD to "1", Timer can cascade to one 16-bit Timer. This 16-bit Timer is controlled by Timer 1, including enable, clock source and prescaler. Timer 1 is MSB and Timer 2 is LSB in value of period and duty.

Bit 6 (TRCB): Timers 1, 2 Read Control Bit

- 0 : When this bit is set to 0, read data from T1PD or T2PD.
- 1 : When this bit is set to 1, read data from T1PD or T2PD, but this is a value of the timer counter.

Bits 5~4 (T1CSS1~T1CSS0): Timer 1 Clock Source Select Bits

T1CSS1	T1CSS0	Timer 1 Clock Source Select
0	0	Fm
0	1	Fs
1	×	T1CK

Bit 3 (T2CSS): Timer 2 Clock Source Select Bit

- 0 : Main clock with prescaler
- 1 : Sub clock with prescaler

Bit 2 (T1S): Timer 1 Start Bit

- 0 : Timer 1 stop
- 1 : Timer 1 start

Bit 1 (T1OMS): Timer 1 Output Mode Select Bit

- 0 : Repeating mode
- 1 : One-shot mode

NOTE

One-shot mode is only used in Timer 1, Capture and PWM1 modes.

Mode Selected	Description
Timer 1	Down-counter will underflow once and cannot auto reload from T1PD.
Capture	In this mode, period and duty of the T1CAP input pin are measured once. This moment free running counter stop and can't detect a change of T1CAP edge.
PWM1	In this mode the microcontroller device will generate one set of PWM1's duty and period, and then free running counter will stop.

Bit 0 (T1OC): Timer 1 Output Flip-Flop Control Bit

0 : T-FF is low

1 : T-FF is high

6.2.28 Bank 2 R7 T1PD (Timer 1 Period Buffer)

Bit 7	Bit 6	Bit 5	Bit 4	Bit 3	Bit 2	Bit 1	Bit 0
PRD1[7]	PRD1[6]	PRD1[5]	PRD1[4]	PRD1[3]	PRD1[2]	PRD1[1]	PRD1[0]

Bits 7~0 (PRD1 [7]~PRD1 [0]): The content of this register is a period of Timer 1.

6.2.29 Bank 2 R8 T1TD (Timer 1 Duty Buffer)

Bit 7	Bit 6	Bit 5	Bit 4	Bit 3	Bit 2	Bit 1	Bit 0
TD1[7]	TD1[6]	TD1[5]	TD1[4]	TD1[3]	TD1[2]	TD1[1]	TD1[0]

Bits 7~0 (TD1 [7]~TD1 [0]): The content of this register is a duty of Timer 1.

6.2.30 Bank 2 R9 T2CR (Timer 2 Control Register)

Bit 7	Bit 6	Bit 5	Bit 4	Bit 3	Bit 2	Bit 1	Bit 0
T2IF	T2IE	T2S	T2MS1	T2MS0	T2P2	T2P1	T2P0

Bit 7 (T2IF): Interrupt Flag of Timer 2 Interrupt

Bit 6 (T2IE): Timer 2 Interrupt Mask Bit

0 : Disable Timer 2 interrupt

1 : Enable Timer 2 interrupt

Bit 5 (T2S): Timer 2 Start Bit

0 : Timer 2 stop

1 : Timer 2 start

Bits 4~3 (T2MS1~T2MS0): Timer 2 Operation Mode Select Bits

T2MS1	T2MS0	Timer 2 Mode Select
0	0	Timer 2
0	1	SPI Baud Rate Generator
1	0	PWM 2
1	1	

Bits 2~0 (T2P2~T2P0): Timer 2 Prescaler Bits

T2P2	T2P1	T2P0	Prescaler
0	0	0	1:2 (Default)
0	0	1	1 : 4
0	1	0	1 : 8
0	1	1	1 : 16
1	0	0	1 : 32
1	0	1	1 : 64
1	1	0	1 : 128
1	1	1	1 : 256

6.2.31 Bank 2 RA T2PD (Timer 2 Period Buffer)

Bit 7	Bit 6	Bit 5	Bit 4	Bit 3	Bit 2	Bit 1	Bit 0
PRD2[7]	PRD2[6]	PRD2[5]	PRD2[4]	PRD2[3]	PRD2[2]	PRD2[1]	PRD2[0]

Bits 7~0 (PRD2 [7]~PRD2 [0]): The content of this register is a period of Timer 2.

6.2.32 Bank 2 RB T2TD (Timer 2 Duty Buffer)

Bit 7	Bit 6	Bit 5	Bit 4	Bit 3	Bit 2	Bit 1	Bit 0
TD2[7]	TD2[6]	TD2[5]	TD2[4]	TD2[3]	TD2[2]	TD2[1]	TD2[0]

Bits 7~0 (TD2 [7]~TD2 [0]): The content of this register is a duty of Timer 2.

6.2.33 Bank 2 RC SPIS (SPI Status Register)

Bit 7	Bit 6	Bit 5	Bit 4	Bit 3	Bit 2	Bit 1	Bit 0
DORD	TD1	TD0	0	OD3	OD4	0	RBF

Bit 7 (DORD): Data Shift Control Bit

0 : Shift left (MSB first)

1 : Shift right (LSB first)

Bits 6~5 (TD1~TD0): SDO Status Output Delay Times Options

TD1	TD0	Delay Time
0	0	8 CLK
0	1	16 CLK
1	0	24 CLK
1	1	32 CLK

Bit 4: Reserved

Bit 3 (OD3): Open-Drain Control Bit

0 : Open-drain disable for SDO

1 : Open-drain enable for SDO

Bit 2 (OD4): Open-Drain Control bit

0 : Open-drain disable for SCK

1 : Open-drain enable for SCK

Bit 1: Reserved

Bit 0 (RBF): Read Buffer Full Flag

0 : Receiving not completed, and SPIRB has not fully exchanged.

1 : Receiving completed, and SPIRB is fully exchanged.

6.2.34 Bank 2 RD SPIC (SPI Control Register)

Bit 7	Bit 6	Bit 5	Bit 4	Bit 3	Bit 2	Bit 1	Bit 0
CES	SPIE	SRO	SSE	SDOC	SBRS2	SBRS1	SBRS0

Bit 7 (CES): Clock Edge Select Bit

0 : Data shift out on rising edge, and shifts in on a falling edge. Data is on hold during low-level.

1 : Data shift out falling edge, and shift in on a rising edge. Data is on hold during high-level.

Bit 6 (SPIE): SPI Enable Bit

0 : Disable SPI mode

1 : Enable SPI mode



Bit 5 (SRO): SPI Read Overflow Bit

0 : No overflow

1 : A new data is received while the previous data is still being held in the SPIRB register. In this situation, the data in SPIB register will be destroyed. To avoid setting this bit, user is required to read the SPIRB register although only transmission is implemented. This can only occur in slave mode.

Bit 4 (SSE): SPI Shift Enable Bit

0 : Reset as soon as the shift is complete, and the next byte is read to shift.

1 : Start to shift, and remain on “1” while the current byte is still being transmitted.

Bit 3 (SDOC): SDO Output Status Control Bit

0 : After a serial data output, the SDO remains high.

1 : After a serial data output, the SDO remains low.

Bits 2~0 (SBR2~SBR0): SPI Baud Rate Select Bits

SBR2	SBR1	SBR0	Mode	SPI Baud Rate
0	0	0	Master	Fosc/2
0	0	1	Master	Fosc/4
0	1	0	Master	Fosc/8
0	1	1	Master	Fosc/16
1	0	0	Master	Fosc/32
1	0	1	Master	Timer 2
1	1	0	Slave	/SS enable
1	1	1	Slave	/SS disable

6.2.35 Bank 2 RE SPIR (SPI Read Buffer)

Bit 7	Bit 6	Bit 5	Bit 4	Bit 3	Bit 2	Bit 1	Bit 0
SRB7	SRB6	SRB5	SRB4	SRB3	SRB2	SRB1	SRB0

Bits 7~0 (SRB7~SRB0): SPI Read Data Buffer

6.2.36 Bank 2 RF SPIW (SPI Write Buffer)

Bit 7	Bit 6	Bit 5	Bit 4	Bit 3	Bit 2	Bit 1	Bit 0
SWB7	SWB6	SWB5	SWB4	SWB3	SWB2	SWB1	SWB0

Bits 7~0 (SWB7~SWB0): SPI Write Data Buffer

6.2.37 Bank 3 R5 URC (UART Control Register)

Bit 7	Bit 6	Bit 5	Bit 4	Bit 3	Bit 2	Bit 1	Bit 0
URTD8	UMODE1	UMODE0	BRATE2	BRATE1	BRATE0	UTBE	TXE

Bit 7 (URTD8): Transmission Data Bit 8

Bits 6~5 (UMODE1~UMODE0): UART Transmission Mode Select Bit

UMODE1	UMODE0	UART Mode
0	0	Mode 1 : 7-Bit
0	1	Mode 2 : 8-Bit
1	0	Mode 3 : 9-Bit
1	1	Reserved

Bits 4~2 (BRATE2~BRATE0): Transmit Baud Rate Select ($T_{UART}=F_c/16$)

BRATE2	BRATE1	BRATE0	Baud Rate	e.g. $F_c = 8 \text{ MHz}$
0	0	0	$T_{UART}/13$	38400
0	0	1	$T_{UART}/26$	19200
0	1	0	$T_{UART}/52$	9600
0	1	1	$T_{UART}/104$	4800
1	0	0	$T_{UART}/208$	2400
1	0	1	$T_{UART}/416$	1200
1	1	0	Timer 1	
1	1	1	Reserved	

Bit 1 (UTBE): UART transfer buffer empty flag. Set to 1 when transfer buffer is empty. Reset to 0 automatically when writing to the URTD register. The UTBE bit will be cleared by hardware when transmission is enabled. The UTBE bit is read-only. Hence, writing to the URTD register is necessary to start transmit shifting.

Bit 0 (TXE): Enable transmission

0 : Disable

1 : Enable

6.2.38 Bank 3 R6 URS (UART Status)

Bit 7	Bit 6	Bit 5	Bit 4	Bit 3	Bit 2	Bit 1	Bit 0
URRD8	EVEN	PRE	PRERR	OVERR	FMERR	URBF	RXE

Bit 7 (URRD8): Receiving Data Bit 8

Bit 6 (EVEN): Select Parity Check

0 : Odd parity

1 : Even parity

Bit 5 (PRE): Enable Parity Addition

0 : Disable

1 : Enable

Bit 4 (PRERR): Parity Error Flag

Set to "1" when parity error occurs and clear to "0" by software.

Bit 3 (OVERR): Over Running Error Flag

Set to "1" when overrun error occurs and clear to "0" by software.

Bit 2 (FMERR): Framing Error Flag

Set to "1" when framing error occurs and clear to "0" by software.

Bit 1 (URBF): UART Read Buffer Full Flag

Set to "1" when one character is received. Reset to "0" automatically when read from URS register. The URBF will be cleared by hardware when enabling receiving. The URBF bit is read-only. Therefore, reading the URS register is necessary to avoid overrun error.

Bit 0 (RXE): Enable Receiving

0 : Disable

1 : Enable

6.2.39 Bank 3 R7 URRD (UART_RD Data Buffer)

Bit 7	Bit 6	Bit 5	Bit 4	Bit 3	Bit 2	Bit 1	Bit 0
URRD7	URRD6	URRD5	URRD4	URRD3	URRD2	URRD1	URRD0

Bits 7~0 (URRD7~URRD0): UART Receive Data Buffer. Read only.

6.2.40 Bank 3 R8 URTD (UART_TD Data Buffer)

Bit 7	Bit 6	Bit 5	Bit 4	Bit 3	Bit 2	Bit 1	Bit 0
URTD7	URTD6	URTD5	URTD4	URTD3	URTD2	URTD1	URTD0

Bits 7~0 (URTD7~URTD0): UART Transmit Data Buffer. Write only.

6.2.41 Bank 3 R9 ADCR (A/D Control Register)

Bit 7	Bit 6	Bit 5	Bit 4	Bit 3	Bit 2	Bit 1	Bit 0
ADRUN	ADP	ADCK1	ADCK0	ADIS3	ADIS2	ADIS1	ADIS0

Bit 7 (ADRUN): AD Conversion Start

0 : Reset on completion of the conversion by hardware, this bit cannot be reset by software.

1 : Conversion starts

Bit 6 (ADP): A/D Power Control

Bits 5~4 (ADCK1~ADCK0): AD Conversion Time Select Bits

ADCK1	ADCK0	Clock Source	Max. Operating Frequency (Fc)
0	0	Fc/4	1 MHz
0	1	Fc/16	4 MHz
1	0	Fc/32	8 MHz
1	1	Fc/64	16 MHz

Bits 3~0 (ADIS3~ADIS0): A/D Input Select Bits

ADIS3	ADIS2	ADIS1	ADIS0	Analog Input Pin
0	0	0	0	AD0
0	0	0	1	AD1
0	0	1	0	AD2
0	0	1	1	AD3
0	1	0	0	AD4
0	1	0	1	AD5
0	1	1	0	AD6
0	1	1	1	AD7
1	0	0	0	AD8
1	0	0	1	AD9
1	0	1	0	AD10
1	0	1	1	AD11

6.2.42 Bank 3 RA ADICH (A/D Input Control Register)

Bit 7	Bit 6	Bit 5	Bit 4	Bit 3	Bit 2	Bit 1	Bit 0
CALI	ADREF	0	0	ADE11	ADE10	ADE9	ADE8

Bit 7 (CALI): Calibration Enable Bit for A/D Offset

- 0 : Disable Calibration
- 1 : Enable Calibration

Bit 6 (ADREF): AD Reference Voltage Input Select

- 0 : Internal VDD, P84 is used as I/O.
- 1 : External reference pin, P84 is used as reference input pin.
External VREF is accuracy better than internal VDD.

Bits 5~4: Reserved

Bits 3~0 (ADE11~ADE8): AD Input Pin Enable Control

- 0 : Functions as I/O pin
- 1 : Functions as analog input pin

6.2.43 Bank 3 RB ADICL (A/D Input Control Register)

Bit 7	Bit 6	Bit 5	Bit 4	Bit 3	Bit 2	Bit 1	Bit 0
ADE7	ADE6	ADE5	ADE4	ADE3	ADE2	ADE1	ADE0

Bits 7~0 (ADE7~ADE0): AD input pin enable control

- 0 : Functions as I/O pin
- 1 : Functions as analog input pin

6.2.44 Bank 3 RC ADDH (AD High 8-bit Data Buffer)

Bit 7	Bit 6	Bit 5	Bit 4	Bit 3	Bit 2	Bit 1	Bit 0
ADD11	ADD10	ADD9	ADD8	ADD7	ADD6	ADD5	ADD4

Bits 7~0 (ADD11~ADD4): AD High 8-Bit Data Buffer

6.2.45 Bank 3 RD ADDL (AD Low 4-bit Data Buffer)

Bit 7	Bit 6	Bit 5	Bit 4	Bit 3	Bit 2	Bit 1	Bit 0
SIGN	VOF[2]	VOF[1]	VOF[0]	ADD3	ADD2	ADD1	ADD0

Bit 7 (SIGN): Polarity Bit of Offset Voltage

- 0 : Negative voltage
- 1 : Positive voltage

Bits 6~4 (VOF[2]~VOF[0]): Offset Voltage Bits

VOF[2]	VOF[1]	VOF[0]	EM78P520N
0	0	0	0LSB
0	0	1	2LSB
0	1	0	4LSB
0	1	1	6LSB
1	0	0	8LSB
1	0	1	10LSB
1	1	0	12LSB
1	1	1	14LSB

Bits 3~0 (ADD3~ADD0): AD Low 4-Bit Data Buffer

6.2.46 Bank 3 RE EIESH (External Interrupt Edge Select High Byte Control Register)

Bit 7	Bit 6	Bit 5	Bit 4	Bit 3	Bit 2	Bit 1	Bit 0
EIES7	EIES6	EIES5	EIES4	EIES3	EIES2	EIES1	EIES0

Bits 7~0 (EIES7~EIES0): External Interrupt 7~0 Edge Select Bit

0 : Falling edge interrupt

1 : Rising edge interrupt

6.2.47 Bank 3 RF EIESL (External Interrupt Edge Select Low Byte Control Register)

Bit 7	Bit 6	Bit 5	Bit 4	Bit 3	Bit 2	Bit 1	Bit 0
0	0	0	ADWK	INTWK9	INTWK8	EIES9	EIES8

Bits 7~5: Reserved

Bit 4 (ADWK): A/D Converter Wake-up Function Enable Bit

0 : Disable

1 : Enable

Bits 3~2 (INTWK9~INTWK8): External Interrupt 9~8 Wake-up Function Enable Bit

0 : Disable

1 : Enable

Bits 1~0 (EIES9~EIES8): External Interrupt 9~8 Edge Select Bit

0 : Falling edge interrupt

1 : Rising edge interrupt



6.2.48 Bank 4 R5 LEDDCR (LED Drive Control Register)

Bit 7	Bit 6	Bit 5	Bit 4	Bit 3	Bit 2	Bit 1	Bit 0
LEDD7	LEDD6	LEDD5	LEDD4	LEDD3	LEDD2	LEDD1	LEDD0

Bits 7~0 (LEDD7~LEDD0): 8-bit LED Drive Control Registers

- 0 : Port 9 functions as normal I/O
- 1 : Port 9 functions as LED direct drive I/O

6.2.49 Bank 4 R6 WBCR (Watch Timer and Buzzer Control Register)

Bit 7	Bit 6	Bit 5	Bit 4	Bit 3	Bit 2	Bit 1	Bit 0
WTCS	WTIE	WTIF	WTSSB1	WTSSB0	BUZE	BSSB1	BSSB0

Bit 7 (WTCS): Watch Timer and Buzzer Clock Source Select Bit

- 0 : Main Clock divided by 256
- 1 : Sub clock

Bit 6 (WTIE): Watch Timer Enable Bit and Interrupt Mask

- 0 : Disable
- 1 : Enable

Bit 5 (WTIF): Watch Timer Interrupt Flag

Bits 4~3 (WTSSB1~ WTSSB0): Watch Timer Interval Select Bits

WTSSB1	WTSSB0	Timer Interval Select (WTCS=1)	Fm=8 MHz (WTCS=0)
0	0	1.0S	1.0S
0	1	0.5S	0.5S
1	0	0.25S	0.25S
1	1	3.91ms	3.91ms

Bit 2 (BUZE): Buzzer Enable and Port 91 as Buzzer Output Pin

- 0 : No action
- 1 : Enable buzzer output

Bits 1~0 (BSSB1~BSSB0): Buzzer Output Frequency Select Bits

BSSB1	BSSB0	Buzzer Signal Select (WTCS=1)	Fm=8 MHz (WTCS=0)
0	0	0.5kHz	0.5kHz
0	1	1kHz	1kHz
1	0	2kHz	2kHz
1	1	4kHz	4kHz

6.2.50 Bank 4 R7 P7IOCR (Port 7 I/O Control Register)

Bit 7	Bit 6	Bit 5	Bit 4	Bit 3	Bit 2	Bit 1	Bit 0
IOC77	IOC76	IOC75	IOC74	IOC73	IOC72	IOC71	IOC70

Bits 7~0 (IOC77~IOC70): Port 7 8-Bit I/O Direction Control Registers

0 : Define Port 7 as output port

1 : Define Port 7 as input port

6.2.51 Bank 4 R8 P8IOCR (Port 8 I/O Control Register)

Bit 7	Bit 6	Bit 5	Bit 4	Bit 3	Bit 2	Bit 1	Bit 0
IOC87	IOC86	IOC85	IOC84	IOC83	IOC82	IOC81	0

Bits 7~1 (IOC87~IOC81): Port 8 7-Bit I/O Direction Control Registers

0 : Define Port 8 as output port

1 : Define Port 8 as input port

Bit 0: Reserved

6.2.52 Bank 4 R9 P9IOCR (Port 9 I/O Control Register)

Bit 7	Bit 6	Bit 5	Bit 4	Bit 3	Bit 2	Bit 1	Bit 0
IOC97	IOC96	IOC95	IOC94	IOC93	IOC92	IOC91	IOC90

Bits 7~0 (IOC97~IOC90): Port 9 8-Bit I/O Direction Control Registers

0 : Define Port 9 as output port

1 : Define Port 9 as input port

6.2.53 Bank 4 RA PAIOCR (Port A I/O Control Register)

Bit 7	Bit 6	Bit 5	Bit 4	Bit 3	Bit 2	Bit 1	Bit 0
IOCA7	IOCA6	IOCA5	IOCA4	IOCA3	IOCA2	IOCA1	IOCA0

Bits 7~0 (IOCA7~IOCA0): Port A 8-Bit I/O Direction Control Registers

0 : Define Port A as output port

1 : Define Port A as input port

6.2.54 Bank 4 RB PBIOCR (Port B I/O Control Register)

Bit 7	Bit 6	Bit 5	Bit 4	Bit 3	Bit 2	Bit 1	Bit 0
IOCB7	IOCB6	IOCB5	IOCB4	IOCB3	IOCB2	IOCB1	IOCB0

Bits 7~0 (IOCB7~IOCB0): Port B 8-Bit I/O Direction Control Registers

0 : Define Port B as output port

1 : Define Port B as input port

6.2.55 Bank 4 RC PCIOCR (Port C I/O Control Register)

Bit 7	Bit 6	Bit 5	Bit 4	Bit 3	Bit 2	Bit 1	Bit 0
1	1	1	1	IOCC3	IOCC2	IOCC1	IOCC0

Bits 7~4: Reserved

Bits 3~0 (IOCC3~IOCC0): Port C 4-Bit I/O Direction Control Registers

0 : Define Port C as output port

1 : Define Port C as input port

6.2.56 Bank 4 RF WKCR (Wake-up Control Register)

Bit 7	Bit 6	Bit 5	Bit 4	Bit 3	Bit 2	Bit 1	Bit 0
INTWK7	INTWK6	INTWK5	INTWK4	INTWK3	INTWK2	INTWK1	INTWK0

Bits 7~0 (INTWK7~INTWK0): External Interrupt 7~0 Wake-up Function Enable Bit

0 : Disable

1 : Enable

6.2.57 Bank 5 R6 UARC2 (UART Control Register 2)

Bit 7	Bit 6	Bit 5	Bit 4	Bit 3	Bit 2	Bit 1	Bit 0
0	0	UARTE	0	UINVEN	0	0	0

Bits 7~6: Reserved

Bit 5 (UARTE): UART Function Enable

0 : UART functions disable. PB4, PB5 as general I/O

1 : UART functions enable. PB4, PB5 as UART Rx, Tx pin

Bit 4: Reserved

Bit 3 (UINVEN): Enable UART TX and Rx Port Inverse Output

0 : Disable Tx and Rx port inverse output

1 : Enable Tx and Rx port inverse output

Bits 2~0: Reserved

6.2.58 Bank 5 R7 P7PHCR (Port 7 Pull-high Control Register)

Bit 7	Bit 6	Bit 5	Bit 4	Bit 3	Bit 2	Bit 1	Bit 0
PH77	PH76	PH75	PH74	PH73	PH72	PH71	PH70

Bits 7~0 (PH77~PH70): Port 7 8-Bit I/O Pull High Control Registers

0 : Disable Pull-high

1 : Enable Pull-high

6.2.59 Bank 5 R8 P8PHCR (Port 8 Pull-high Control Register)

Bit 7	Bit 6	Bit 5	Bit 4	Bit 3	Bit 2	Bit 1	Bit 0
PH87	PH86	PH85	PH84	PH83	PH82	PH81	0

Bits 7~1 (PH87~PH81): PORT 8 7-Bit I/O Pull High Control Registers

0 : Disable Pull-high

1 : Enable Pull-high

Bit 0: Reserved

6.2.60 Bank 5 R9 P9PHCR (Port 9 Pull-high Control Register)

Bit 7	Bit 6	Bit 5	Bit 4	Bit 3	Bit 2	Bit 1	Bit 0
PH97	PH96	PH95	PH94	PH93	PH92	PH91	PH90

Bits 7~0 (PH97~PH90): Port 9 8-bit I/O Pull-high Control Registers

0 : Disable Pull-high

1 : Enable Pull-high

6.2.61 Bank 5 RA PAPHCR (Port A Pull-high Control Register)

Bit 7	Bit 6	Bit 5	Bit 4	Bit 3	Bit 2	Bit 1	Bit 0
PHA7	PHA6	PHA5	PHA4	PHA3	PHA2	PHA1	PHA0

Bits 7~0 (PHA7~PHA0): Port A 8-bit I/O Pull-high Control Registers

0 : Disable Pull-high

1 : Enable Pull-high

6.2.62 Bank 5 RB PBPBHC (Port B Pull-high Control Register)

Bit 7	Bit 6	Bit 5	Bit 4	Bit 3	Bit 2	Bit 1	Bit 0
PHB7	PHB6	PHB5	PHB4	PHB3	PHB2	PHB1	PHB0

Bits 7~0 (PHB7~PHB0): Port B 8-Bit I/O Pull-high Control Registers

0 : Disable Pull-high

1 : Enable Pull-high

6.2.63 Bank 5 RC PCPHCR (Port C Pull High Control Register)

Bit 7	Bit 6	Bit 5	Bit 4	Bit 3	Bit 2	Bit 1	Bit 0
0	0	0	0	PHC3	PHC2	PHC1	PHC0

Bits 7~4: Reserved

Bits 3~0 (PHC3~PHC0): Port C 4-Bit I/O Pull-high Control Registers

0 : Disable Pull-high

1 : Enable Pull-high

6.2.64 Bank 6 R6 LVRCCR (Low Voltage Reset Control Register)

Bit 7	Bit 6	Bit 5	Bit 4	Bit 3	Bit 2	Bit 1	Bit 0
0	0	0	0	0	LVREN	LVR1S	LVR0S

R6 uses only ICE520 simulator.

Bits 7~3: Reserved

Bit 2 (LVREN): Low Voltage Reset Enable Bit

0 : Disable

1 : Enable

Bits 1~0 (LVR1S~LVR0S): Low Voltage Reset Voltage Select Bits

LVR1S	LVR0S	Reset Voltage
0	0	2.6V
0	1	3.3V
1	0	3.9V

6.2.65 Bank 6 R7 P7ODCR (Port 7 Open Drain Control Register)

Bit 7	Bit 6	Bit 5	Bit 4	Bit 3	Bit 2	Bit 1	Bit 0
OD77	OD76	OD75	OD74	OD73	OD72	OD71	OD70

Bits 7~0 (OD77~OD70): Port 7 8-Bit I/O Open Drain Control Registers

0 : Disable Open drain

1 : Enable Open drain

6.2.66 Bank 6 R8 P8ODCR (Port 8 Open Drain Control Register)

Bit 7	Bit 6	Bit 5	Bit 4	Bit 3	Bit 2	Bit 1	Bit 0
OD87	OD86	OD85	OD84	OD83	OD82	OD81	0

Bits 7~1 (OD87~OD80): Port 8 7-bit I/O Open Drain Control Registers

0 : Disable Open drain

1 : Enable Open drain

Bit 0: Reserved

6.2.67 Bank 6 R9 P9ODCR (Port 9 Open Drain Control Register)

Bit 7	Bit 6	Bit 5	Bit 4	Bit 3	Bit 2	Bit 1	Bit 0
OD97	OD96	OD95	OD94	OD93	OD92	OD91	OD90

Bits 7~0 (OD97~OD90): Port 9 8-Bit I/O Open Drain Control Registers

0 : Disable Open drain

1 : Enable Open drain

6.2.68 Bank 6 RA PAODCR (Port A Open Drain Control Register)

Bit 7	Bit 6	Bit 5	Bit 4	Bit 3	Bit 2	Bit 1	Bit 0
ODA7	ODA6	ODA5	ODA4	ODA3	ODA2	ODA1	ODA0

Bits 7~0 (ODA7~ODA0): Port A 8-Bit I/O Open Drain Control Registers

0 : Disable Open drain

1 : Enable Open drain

6.2.69 Bank 6 RB PBODCR (Port B Open Drain Control Register)

Bit 7	Bit 6	Bit 5	Bit 4	Bit 3	Bit 2	Bit 1	Bit 0
ODB7	ODB6	ODB5	ODB4	ODB3	ODB2	ODB1	ODB0

Bits 7~0 (ODB7~ODB0): Port B 8-Bit I/O Open Drain Control Registers

0 : Disable Open drain

1 : Enable Open drain

6.2.70 Bank 6 RC (Port C)

Bit 7	Bit 6	Bit 5	Bit 4	Bit 3	Bit 2	Bit 1	Bit 0
1	1	1	1	RC3	RC2	RC1	RC0

Bits 7~4: Reserved

Bits 3~0 (RC3~RC0): Port C 4-Bit I/O Registers

6.2.71 R10~R3F (General Purpose Register)

R10~R1F and R20~R3F (Banks 0~7) are general purpose registers.

6.3 TCC/WDT Prescaler

Registers for the TCC/WDT Circuit

R_BANK	Address	Name	Bit 7	Bit 6	Bit 5	Bit 4	Bit 3	Bit 2	Bit 1	Bit 0
Bank 0	0X0D	TWTCR	WDTE	WPSR2	WPSR1	WPSR0	TCCS	TPSR2	TPSR1	TPSR0
			R/W	R/W	R/W	R/W	R/W	R/W	R/W	R/W
Bank 0	0x0E	IMR	T1IE	LVDIE	ADIE	SPIIE	URTIE	EXIE9	EXIE8	TCIE
			R/W	R/W	R/W	R/W	R/W	R/W	R/W	R/W
Bank 0	0x0F	ISR	T1IF	LVDIF	ADIF	SPIIF	URTIF	EXIF9	EXIF8	TCIF
			R/W	R/W	R/W	R/W	R/W	R/W	R/W	R/W

There are two 8-bit counters available as prescalers for the TCC and WDT, respectively. The TPSR0~TPSR2 bits of the Bank 0 RD (TWTCR) register are used to determine the ratio of the TCC prescaler. Likewise, the WPSR0~WPSR2 bits of the Bank 0 RD (TWTCR) register are used to determine the WDT prescaler. The prescaler counter will be cleared by the instructions each time they are written into TCC. The WDT and prescaler will be cleared by the “WDTC” and “SLEP” instructions. Figure 6-4 depicts the circuit diagram of TCC/WDT.

R1 (TCC) is an 8-bit timer/counter. The TCC clock source can be internal clock main clock or sub clock (32.768kHz). If TCC signal source is from the internal clock, TCC will be incremented by 1 at every instruction cycle (without prescaler). As illustrated in Figure 6-4. The watchdog timer is a free running on-chip RC oscillator. The WDT will continue running even after the oscillator driver has been turned off (i.e. in sleep mode). During normal operation or sleep mode, a WDT time-out (if enabled) will cause the device to reset. The WDT can be enabled or disabled at any time during the normal mode by software programming. Refer to WDTE bit of Bank 0 RD (TWTCR) register. With no prescaler, the WDT time-out period is approximately 18 ms¹.

¹ **Note:** VDD=5V, Setup time period = 16.5ms ± 30%
VDD=3V, Setup time period = 18ms ± 30%
Setup time form the WDT.

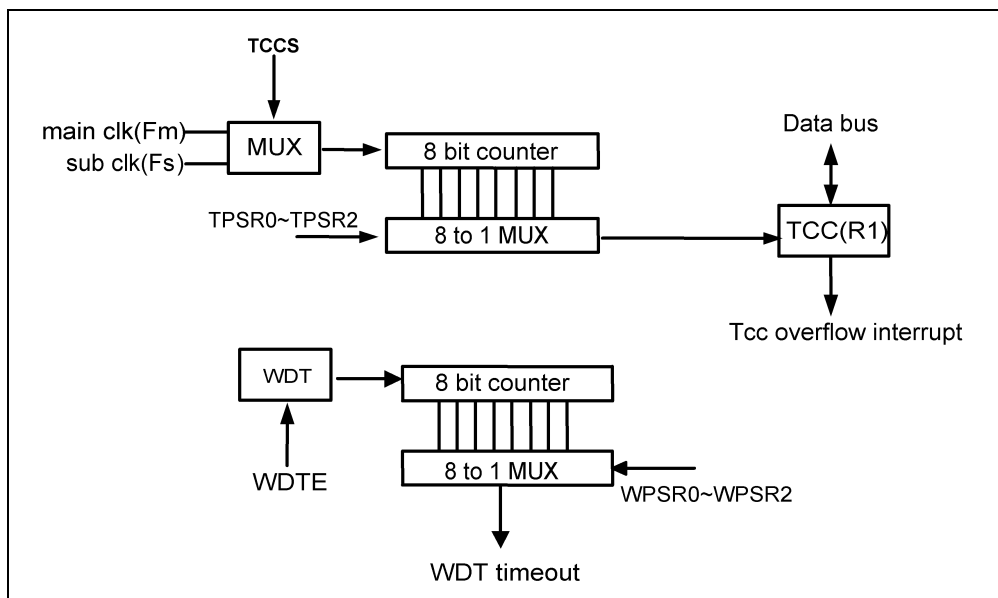

Figure 6-4 TCC/WDT Block Diagram

6.4 I/O Port

Registers for I/O Circuit

R_BANK	Address	Name	Bit 7	Bit 6	Bit 5	Bit 4	Bit 3	Bit 2	Bit 1	Bit 0
Bank 4	0X07~0X0C	PIOCR	IOC7	IOC6	IOC5	IOC4	IOC3	IOC2	IOC1	IOC0
			R/W	R/W	R/W	R/W	R/W	R/W	R/W	R/W
Bank 5	0X07~0X0C	PHCR	PH7	PH6	PH5	PH4	PH3	PH2	PH1	PH0
			R/W	R/W	R/W	R/W	R/W	R/W	R/W	R/W
Bank 6	0X07~0X0B	ODCR	OD7	OD6	OD5	OD4	OD3	OD2	OD1	OD0
			R/W	R/W	R/W	R/W	R/W	R/W	R/W	R/W

The I/O registers, (Port 7, Port 8, Port 9, Port A, Port B and Port C), are bidirectional tri-state I/O ports. All pins are pulled-high internally by software. Likewise, Port 7, Port 8, Port 9, Port A, Port B and Port C, can also have open-drain output through software. Port 7 [7:4], Port B [3:0] and Port 8 [3:2] provides an input status changed interrupt (or wake-up) function and is pulled-high by software. Each I/O pin can be defined as "input" or "output" pin by the I/O control register Bank 4 R7 ~ RC. The I/O registers and I/O control registers are both readable and writable. The I/O interface circuits are shown in Figure 6-5.

The I/O cannot be set to pull-high and output low at the same time. It can relatively increase the power consumption.

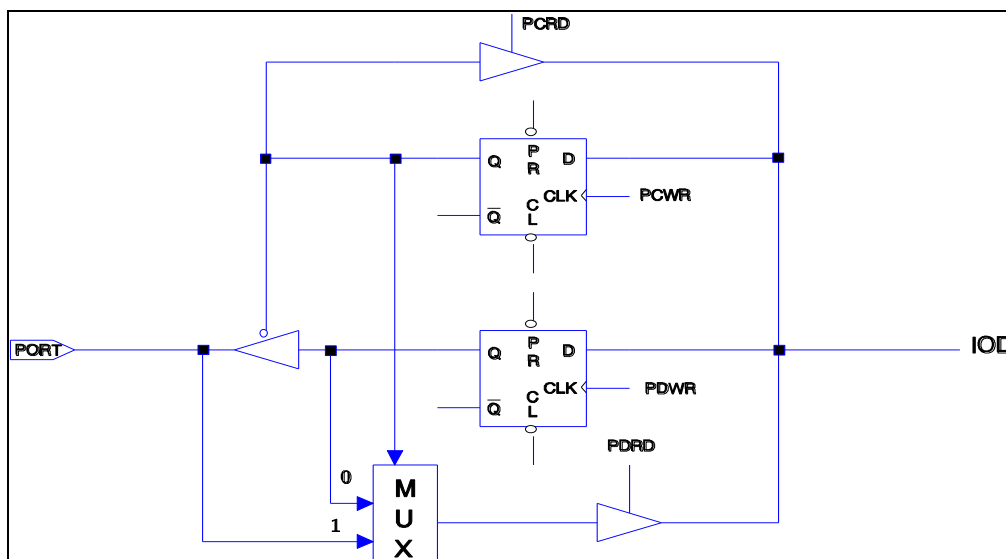

Note: Open-drain is not shown in the figure.

Figure 6-5 Circuits of I/O Port and I/O Control Register for Ports 7~9, and Ports A~C

6.5 Reset and Wake-up

A reset can be caused by:

- Power-on reset
- WDT timeout (if enabled)
- LVR Reset (if enabled)
- RESET pin pulling low

NOTE

The power-on reset circuit is always enabled, it will reset the CPU at 2.3V and power consumption is 0.5 μ A.

Once a reset occurs, the following functions are performed:

- The oscillator is running, or will be started.
- The Program Counter (R2) is set to all "0".
- All I/O port pins are configured as input mode (high-impedance state).
- The TCC/Watchdog timer and prescaler are cleared.
- When power is on, all bits of R5 and R6 are cleared.
- The other registers are described in Table 2

Table 2 Summary of the Registers Initial Values

Address	Name	Reset Type	Bit 7	Bit 6	Bit 5	Bit 4	Bit 3	Bit 2	Bit 1	Bit 0
0x00	R0 IAR	Bit Name	-	-	-	-	-	-	-	-
		Power-on	U	U	U	U	U	U	U	U
		/RESET and WDT	P	P	P	P	P	P	P	P
		Wake-up from Sleep and Idle mode	P	P	P	P	P	P	P	P
0x01	R1 TCC	Bit Name	-	-	-	-	-	-	-	-
		Power-on	0	0	0	0	0	0	0	0
		/RESET and WDT	0	0	0	0	0	0	0	0
		Wake-up from Sleep and Idle mode	P	P	P	P	P	P	P	P
0x02	R2 PC	Bit Name	-	-	-	-	-	-	-	-
		Power-on	0	0	0	0	0	0	0	0
		/RESET and WDT	0	0	0	0	0	0	0	0
		Wake-up from Sleep and Idle mode	Continue to execute next instruction							
0x03	R3 LVD & SR	Bit Name	LV DEN	LV DS1	LV DS0	T	P	Z	DC	C
		Power-on	0	0	0	1	1	U	U	U
		/RESET and WDT	0	0	0	t	t	P	P	P
		Wake-up from Sleep and Idle mode	P	P	P	t	t	P	P	P
0x04	R4 RSR	Bit Name	VDB	BNC	X	X	X	X	X	X
		Power-on	1	1	U	U	U	U	U	U
		/RESET and WDT	1	1	P	P	P	P	P	P
		Wake-up from Sleep and Idle mode	P	P	P	P	P	P	P	P
0x05	Bank 0 R5 RBSR	Bit Name	0	0	0	0	0	BS2	BS1	BS0
		Power-on	0	0	0	0	0	0	0	0
		/RESET and WDT	0	0	0	0	0	0	0	0
		Wake-up from Sleep and Idle mode	P	P	P	P	P	P	P	P
0x07	Bank 0 R7 Port 7	Bit Name	R77	R76	R75	R74	R73	R62	R71	R70
		Power-on	1	1	1	1	1	1	1	1
		/RESET and WDT	1	1	1	1	1	1	1	1
		Wake-up from Sleep and Idle mode	P	P	P	P	P	P	P	P
0x08	Bank 0 R8 Port 8	Bit Name	R87	R86	R85	R84	R83	R82	R81	0
		Power-on	1	1	1	1	1	1	1	0
		/RESET and WDT	1	1	1	1	1	1	1	0
		Wake-up from Sleep and Idle mode	P	P	P	P	P	P	P	0



Address	Name	Reset Type	Bit 7	Bit 6	Bit 5	Bit 4	Bit 3	Bit 2	Bit 1	Bit 0
0x09	Bank 0 R9 Port 9	Bit Name	R97	R96	R95	R94	R93	R92	R91	R90
		Power-on	1	1	1	1	1	1	1	1
		/RESET and WDT	1	1	1	1	1	1	1	1
		Wake-up from Sleep and Idle mode	P	P	P	P	P	P	P	P
0x0A	Bank 0 RA Port A	Bit Name	RA7	RA6	RA5	RA4	RA3	RA2	RA1	RA0
		Power-on	1	1	1	1	1	1	1	1
		/RESET and WDT	1	1	1	1	1	1	1	1
		Wake-up from Sleep and Idle mode	P	P	P	P	P	P	P	P
0x0B	Bank 0 RB Port B	Bit Name	RB7	RB6	RB5	RB4	RB3	RB2	RB1	RB0
		Power-on	1	1	1	1	1	1	1	1
		/RESET and WDT	1	1	1	1	1	1	1	1
		Wake-up from Sleep and Idle mode	P	P	P	P	P	P	P	P
0x0C	Bank 0 RC SCCR	Bit Name	0	CLK2	CKL1	CLK0	IDLE	0	0	CPUS
		Power-on	0	0	0	0	1	0	0	1
		/RESET and WDT	0	0	0	0	1	0	0	1
		Wake-up from Sleep and Idle mode	P	P	P	P	P	P	P	P
0x0D	Bank 0 RD TWTCR	Bit Name	WDTE	WPSR2	WPSR1	WPSR0	TCCS	TPSR2	TPSR1	TPSR0
		Power-on	0	0	0	0	0	0	0	0
		/RESET and WDT	0	0	0	0	0	0	0	0
		Wake-up from Sleep and Idle mode	P	P	P	P	P	P	P	P
0x0E	Bank 0 RE IMR	Bit Name	T11E	LVDIE	ADIE	SPIIE	URTIE	EXIE9	EXIE8	TCIE
		Power-on	0	0	0	0	0	0	0	0
		/RESET and WDT	0	0	0	0	0	0	0	0
		Wake-up from Sleep and Idle mode	P	P	P	P	P	P	P	P
0x0F	Bank 0 RF ISR	Bit Name	T11F	LVDIF	ADIF	SPIIF	URTIF	EXIF9	EXIF8	TCIF
		Power-on	0	0	0	0	0	0	0	0
		/RESET and WDT	0	0	0	0	0	0	0	0
		Wake-up from Sleep and Idle mode	P	P	P	P	P	P	P	P
0x05	Bank 1 R5 LCDCR	Bit Name	LCDEN	LCPYE	BS1	BS0	DS1	DS0	LCDF1	LCDF0
		Power-on	0	0	0	0	0	0	0	0
		/RESET and WDT	0	0	0	0	0	0	0	0
		Wake-up from Sleep and Idle mode	P	P	P	P	P	P	P	P
0x06	Bank 1 R6 LCDAR	Bit Name	0	0	0	LCD_A4	LCD_A3	LCD_A2	LCD_A1	LCD_A0
		Power-on	0	0	0	0	0	0	0	0
		/RESET and WDT	0	0	0	0	0	0	0	0
		Wake-up from Sleep and Idle mode	P	P	P	P	P	P	P	P



Address	Name	Reset Type	Bit 7	Bit 6	Bit 5	Bit 4	Bit 3	Bit 2	Bit 1	Bit 0
0x07	Bank 1 R7 LCDBR	Bit Name	LCD_D7	LCD_D6	LCD_D5	LCD_D4	LCD_D3	LCD_D2	LCD_D1	LCD_D0
		Power-on	0	0	0	0	0	0	0	0
		/RESET and WDT	0	0	0	0	0	0	0	0
		Wake-up from Sleep and Idle mode	P	P	P	P	P	P	P	P
0x08	Bank 1 R8 (LCDVCR)	Bit Name	0	0	0	LCDC1	LCDC0	LCDVC2	LCDVC1	LCDVC0
		Power-on	0	0	0	1	1	1	1	1
		/RESET and WDT	0	0	0	1	1	1	1	1
		Wake-up from Sleep and Idle mode	P	P	P	P	P	P	P	P
0x09	Bank 1 R9 LCDCCR	Bit Name	COM7	COM6	COM5	COM4	COM3	COM2	COM1	COM0
		Power-on	0	0	0	0	0	0	0	0
		/RESET and WDT	0	0	0	0	0	0	0	0
		Wake-up from Sleep and Idle mode	P	P	P	P	P	P	P	P
0x0A	Bank 1 RA (LCDSCRO)	Bit Name	SEG7	SEG6	SEG5	SEG4	SEG3	SEG2	SEG1	SEG0
		Power-on	0	0	0	0	0	0	0	0
		/RESET and WDT	0	0	0	0	0	0	0	0
		Wake-up from Sleep and Idle mode	P	P	P	P	P	P	P	P
0x0B	Bank 1 RB LCDSCR1	Bit Name	SEG15	SEG14	SEG13	SEG12	SEG11	SEG10	SEG9	SEG8
		Power-on	0	0	0	0	0	0	0	0
		/RESET and WDT	0	0	0	0	0	0	0	0
		Wake-up from Sleep and Idle mode	P	P	P	P	P	P	P	P
0x0C	Bank 1 RC LCDSCR 2	Bit Name	0	SEG22	SEG21	SEG20	SEG19	SEG18	SEG17	SEG16
		Power-on	0	0	0	0	0	0	0	0
		/RESET and WDT	0	0	0	0	0	0	0	0
		Wake-up from Sleep and Idle mode	P	P	P	P	P	P	P	P
0x0E	Bank 1 RE EIMR	Bit Name	EXIE7	EXIE6	EXIE5	EXIE4	EXIE3	EXIE2	EXIE1	EXIE0
		Power-on	0	0	0	0	0	0	0	0
		/RESET and WDT	0	0	0	0	0	0	0	0
		Wake-up from Sleep and Idle mode	P	P	P	P	P	P	P	P
0x0F	Bank 1 RF EISR	Bit Name	EXIF7	EXIF6	EXIF5	EXIF4	EXIF3	EXIF2	EXIF1	EXIF0
		Power-on	0	0	0	0	0	0	0	0
		/RESET and WDT	0	0	0	0	0	0	0	0
		Wake-up from Sleep and Idle mode	P	P	P	P	P	P	P	P
0x05	Bank 2 R5 T1CR	Bit Name	TIS1	TIS0	T1MS2	T1MS1	TIMS0	T1P2	T1P1	T1P0
		Power-on	0	0	0	0	0	0	0	0
		/RESET and WDT	0	0	0	0	0	0	0	0
		Wake-up from Sleep and Idle mode	P	P	P	P	P	P	P	P



Address	Name	Reset Type	Bit 7	Bit 6	Bit 5	Bit 4	Bit 3	Bit 2	Bit 1	Bit 0
0x06	Bank 2 R6 TSR	Bit Name	T1MOD	TCRB	T1CSS1	T1CSS0	T2CSS	T1S	T1OMS	T1OC
		Power-on	0	0	0	0	0	0	0	0
		/RESET and WDT	0	0	0	0	0	0	0	0
		Wake-up from Sleep and Idle mode	P	P	P	P	P	P	P	P
0x07	Bank 2 R7 T1PD	Bit Name	PRD1[7]	PRD1[6]	PRD1[5]	PRD1[4]	PRD1[3]	PRD1[2]	PRD1[1]	PRD1[0]
		Power-on	0	0	0	0	0	0	0	0
		/RESET and WDT	0	0	0	0	0	0	0	0
		Wake-up from Sleep and Idle mode	P	P	P	P	P	P	P	P
0x08	Bank 2 R8 T1TD	Bit Name	TD1[7]	TD1[6]	TD1[5]	TD1[4]	TD1[3]	TD1[2]	TD1[1]	TD1[0]
		Power-on	0	0	0	0	0	0	0	0
		/RESET and WDT	0	0	0	0	0	0	0	0
		Wake-up from Sleep and Idle mode	P	P	P	P	P	P	P	P
0x09	Bank 2 R9 T2CR	Bit Name	T2IF	T2IE	T2S	T2MS1	T2MS0	T2P2	T2P1	T2P0
		Power-on	0	0	0	0	0	0	0	0
		/RESET and WDT	0	0	0	0	0	0	0	0
		Wake-up from Sleep and Idle mode	P	P	P	P	P	P	P	P
0x0A	Bank 2 RA T2PD	Bit Name	PRD2[7]	PRD2[6]	PRD2[5]	PRD2[4]	PRD2[3]	PRD2[2]	PRD2[1]	PRD2[0]
		Power-on	0	0	0	0	0	0	0	0
		/RESET and WDT	0	0	0	0	0	0	0	0
		Wake-up from Sleep and Idle mode	P	P	P	P	P	P	P	P
0x0B	Bank 2 RB T2TD	Bit Name	TD2[7]	TD2[6]	TD2[5]	TD2[4]	TD2[3]	TD2[2]	TD2[1]	TD2[0]
		Power-on	0	0	0	0	0	0	0	0
		/RESET and WDT	0	0	0	0	0	0	0	0
		Wake-up from Sleep and Idle mode	P	P	P	P	P	P	P	P
0x0C	Bank 2 RC SPIS	Bit Name	DORD	TD1	TD0	0	OD3	OD4	0	RBF
		Power-on	0	0	0	0	0	0	0	0
		/RESET and WDT	0	0	0	0	0	0	0	0
		Wake-up from Sleep and Idle mode	P	P	P	P	P	P	P	P
0x0D	Bank 2 RD SPIC	Bit Name	CES	SPIE	SRO	SSE	SDOC	SBRS2	SBRS1	SBRS0
		Power-on	0	0	0	0	0	0	0	0
		/RESET and WDT	0	0	0	0	0	0	0	0
		Wake-up from Sleep and Idle mode	P	P	P	P	P	P	P	P
0x0E	Bank 2 RE SPIR	Bit Name	SRB7	SRB6	SRB5	SRB4	SRB3	SRB2	SRB1	SRB0
		Power-on	U	U	U	U	U	U	U	U
		/RESET and WDT	U	U	U	U	U	U	U	U
		Wake-up from Sleep and Idle mode	P	P	P	P	P	P	P	P



Address	Name	Reset Type	Bit 7	Bit 6	Bit 5	Bit 4	Bit 3	Bit 2	Bit 1	Bit 0
0x0F	Bank 2 RF SPIW	Bit Name	SWB7	SWB6	SWB5	SWB4	SWB3	SWB2	SWB1	SWB0
		Power-on	U	U	U	U	U	U	U	U
		/RESET and WDT	U	U	U	U	U	U	U	U
		Wake-up from Sleep and Idle mode	P	P	P	P	P	P	P	P
0x05	Bank 3 R5 URC	Bit Name	URTD8	UMODE1	UMODE0	BRATE2	BRATE1	BRATE0	UTBE	TXE
		Power-on	U	0	0	0	0	0	0	0
		/RESET and WDT	P	0	0	0	0	0	0	0
		Wake-up from Sleep and Idle mode	P	P	P	P	P	P	P	P
0x06	Bank 3 R6 URS	Bit Name	URRD8	EVEN	PRE	PRERR	OVERR	FMERR	URBF	RXE
		Power-on	U	0	0	0	0	0	0	0
		/RESET and WDT	P	0	0	0	0	0	0	0
		Wake-up from Sleep and Idle mode	P	P	P	P	P	P	P	P
0x07	Bank 3 R7 URRD	Bit Name	URRD7	URRD6	URRD5	URRD4	URRD3	URRD2	URRD1	URRD0
		Power-on	0	0	0	0	0	0	0	0
		/RESET and WDT	P	P	P	P	P	P	P	P
		Wake-up from Sleep and Idle mode	P	P	P	P	P	P	P	P
0x08	Bank 3 R8 (URTD)	Bit Name	URTD7	URTD6	URTD5	URTD4	URTD3	URTD2	URTD1	URTD0
		Power-on	0	0	0	0	0	0	0	0
		/RESET and WDT	P	P	P	P	P	P	P	P
		Wake-up from Sleep and Idle mode	P	P	P	P	P	P	P	P
0x09	Bank 3 R9 ADCR	Bit Name	ADRUN	ADP	ADCK1	ADCK0	ADIS3	ADIS2	ADIS1	ADIS0
		Power-on	0	0	0	0	0	0	0	0
		/RESET and WDT	0	0	0	0	0	0	0	0
		Wake-up from Sleep and Idle mode	P	P	P	P	P	P	P	P
0x0A	Bank 3 RA ADICH	Bit Name	CALI	ADREF	0	0	ADE11	ADE10	ADE9	ADE8
		Power-on	0	0	0	0	0	0	0	0
		/RESET and WDT	0	0	0	0	0	0	0	0
		Wake-up from Sleep and Idle mode	P	P	P	P	P	P	P	P
0x0B	Bank 3 RB (ADICL)	Bit Name	ADE7	ADE6	ADE5	ADE4	ADE3	ADE2	ADE1	ADE0
		Power-on	0	0	0	0	0	0	0	0
		/RESET and WDT	0	0	0	0	0	0	0	0
		Wake-up from Sleep and Idle mode	P	P	P	P	P	P	P	P
0x0C	Bank 3 RC ADDH	Bit Name	ADD11	ADD10	ADD9	ADD8	ADD7	ADD6	ADD5	ADD4
		Power-on	0	0	0	0	0	0	0	0
		/RESET and WDT	0	0	0	0	0	0	0	0
		Wake-up from Sleep and Idle mode	P	P	P	P	P	P	P	P



Address	Name	Reset Type	Bit 7	Bit 6	Bit 5	Bit 4	Bit 3	Bit 2	Bit 1	Bit 0
0x0D	Bank 3 RD ADDL	Bit Name	SIGN	VOF[2]	VOF[1]	VOF[0]	ADD3	ADD2	ADD1	ADD0
		Power-on	0	0	0	0	0	0	0	0
		/RESET and WDT	0	0	0	0	0	0	0	0
		Wake-up from Sleep and Idle mode	P	P	P	P	P	P	P	P
0x0E	Bank 3 RE EIESH	Bit Name	EIES7	EIES6	EIES5	EIES4	EIES3	EIES2	EIES1	EIES0
		Power-on	0	0	0	0	0	0	0	0
		/RESET and WDT	0	0	0	0	0	0	0	0
		Wake-up from Sleep and Idle mode	P	P	P	P	P	P	P	P
0x0F	Bank 3 RF EIESL	Bit Name	0	0	0	ADWK	INTWK9	INTWK8	EIES9	EIES8
		Power-on	0	0	0	0	0	0	0	0
		/RESET and WDT	0	0	0	0	0	0	0	0
		Wake-up from Sleep and Idle mode	P	P	P	P	P	P	P	P
0x05	Bank 4 R5 LEDDCR	Bit Name	LEDD7	LEDD6	LEDD5	LEDD4	LEDD3	LEDD2	LEDD1	LEDD0
		Power-on	0	0	0	0	0	0	0	0
		/RESET and WDT	0	0	0	0	0	0	0	0
		Wake-up from Sleep and Idle mode	P	P	P	P	P	P	P	P
0x06	Bank 4 R6 WBCR	Bit Name	WTCS	WTIE	WTIF	WTSSB1	WTSSB0	BUZE	BSSB1	BSSB0
		Power-on	0	0	0	0	0	0	0	0
		/RESET and WDT	0	0	0	0	0	0	0	0
		Wake-up from Sleep and Idle mode	P	P	P	P	P	P	P	P
0x07	Bank 4 R7 P7IOCR	Bit Name	IOC77	IOC76	IOC75	IOC74	IOC73	IOC72	IOC71	IOC70
		Power-on	1	1	1	1	1	1	1	1
		/RESET and WDT	1	1	1	1	1	1	1	1
		Wake-up from Sleep and Idle mode	P	P	P	P	P	P	P	P
0x08	Bank 4 R8 P8IOCR	Bit Name	IOC87	IOC86	IOC85	IOC84	IOC83	IOC82	IOC81	0
		Power-on	1	1	1	1	1	1	1	0
		/RESET and WDT	1	1	1	1	1	1	1	0
		Wake-up from Sleep and Idle mode	P	P	P	P	P	P	P	P
0x09	Bank 4 R9 P9IOCR	Bit Name	IOC97	IOC96	IOC95	IOC94	IOC93	IOC92	IOC91	IOC90
		Power-on	1	1	1	1	1	1	1	1
		/RESET and WDT	1	1	1	1	1	1	1	1
		Wake-up from Sleep and Idle mode	P	P	P	P	P	P	P	P
0x0A	Bank 4 RA PAIOCR	Bit Name	IOCA7	IOCA6	IOCA5	IOCA4	IOCA3	IOCA2	IOCA1	IOCA0
		Power-on	1	1	1	1	1	1	1	1
		/RESET and WDT	1	1	1	1	1	1	1	1
		Wake-up from Sleep and Idle mode	P	P	P	P	P	P	P	P



Address	Name	Reset Type	Bit 7	Bit 6	Bit 5	Bit 4	Bit 3	Bit 2	Bit 1	Bit 0
0x0B	Bank 4 RB PBIOCR	Bit Name	IOCB7	IOCB6	IOCB5	IOCB4	IOCB3	IOCB2	IOCB1	IOCB0
		Power-on	1	1	1	1	1	1	1	1
		/RESET and WDT	1	1	1	1	1	1	1	1
		Wake-up from Sleep and Idle mode	P	P	P	P	P	P	P	P
0x0C	Bank 4 RC PCIOCR	Bit Name	1	1	1	1	IOCC3	IOCC2	IOCC1	IOCC0
		Power-on	1	1	1	1	1	1	1	1
		/RESET and WDT	1	1	1	1	1	1	1	1
		Wake-up from Sleep and Idle mode	P	P	P	P	P	P	P	P
0x0F	Bank 4 RF WKCR	Bit Name	INTWK7	INTWK6	INTWK5	INTWK4	INTWK3	INTWK2	INTWK1	INTWK0
		Power-on	0	0	0	0	0	0	0	0
		/RESET and WDT	0	0	0	0	0	0	0	0
		Wake-up from Sleep and Idle mode	P	P	P	P	P	P	P	P
0x06	Bank 5 R6 UARC2	Bit Name	0	0	UARTE	0	UINVEN	0	0	0
		Power-on	0	0	0	0	0	0	0	0
		/RESET and WDT	0	0	0	0	0	0	0	0
		Wake-up from Sleep and Idle mode	P	P	P	P	P	P	P	P
0x07	Bank 5 R7 P7PHCR	Bit Name	PH77	PH76	PH75	PH74	PH73	PH72	PH71	PH70
		Power-on	0	0	0	0	0	0	0	0
		/RESET and WDT	0	0	0	0	0	0	0	0
		Wake-up from Sleep and Idle mode	P	P	P	P	P	P	P	P
0x08	Bank 5 R8 P8PHCR	Bit Name	PH87	PH86	PH85	PH84	PH83	PH82	PH81	0
		Power-on	0	0	0	0	0	0	0	0
		/RESET and WDT	0	0	0	0	0	0	0	0
		Wake-up from Sleep and Idle mode	P	P	P	P	P	P	P	P
0x09	Bank 5 R9 P9PHCR	Bit Name	PH97	PH96	PH95	PH94	PH93	PH92	PH91	PH90
		Power-on	0	0	0	0	0	0	0	0
		/RESET and WDT	0	0	0	0	0	0	0	0
		Wake-up from Sleep and Idle mode	P	P	P	P	P	P	P	P
0x0A	Bank 5 RA PAPHCR	Bit Name	PHA7	PHA6	PHA5	PHA4	PHA3	PHA2	PHA1	PHA0
		Power-on	0	0	0	0	0	0	0	0
		/RESET and WDT	0	0	0	0	0	0	0	0
		Wake-up from Sleep and Idle mode	P	P	P	P	P	P	P	P
0x0B	Bank 5 RB PBPHCR	Bit Name	PHB7	PHB6	PHB5	PHB4	PHB3	PHB2	PHB1	PHB0
		Power-on	0	0	0	0	0	0	0	0
		/RESET and WDT	0	0	0	0	0	0	0	0
		Wake-up from Sleep and Idle mode	P	P	P	P	P	P	P	P



Address	Name	Reset Type	Bit 7	Bit 6	Bit 5	Bit 4	Bit 3	Bit 2	Bit 1	Bit 0
0x0C	Bank 5 RC PCPHCR	Bit Name	0	0	0	0	PHC3	PHC2	PHC1	PHC0
		Power-on	0	0	0	0	0	0	0	0
		/RESET and WDT	0	0	0	0	0	0	0	0
		Wake-up from Sleep and Idle mode	P	P	P	P	P	P	P	P
0x07	Bank 6 R7 P7ODCR	Bit Name	OD77	OD76	OD75	OD74	OD73	OD72	OD71	OD70
		Power-on	0	0	0	0	0	0	0	0
		/RESET and WDT	0	0	0	0	0	0	0	0
		Wake-up from Sleep and Idle mode	P	P	P	P	P	P	P	P
0x08	Bank 6 R8 P8ODCR	Bit Name	OD87	OD86	OD85	OD84	OD83	OD82	OD81	0
		Power-on	0	0	0	0	0	0	0	0
		/RESET and WDT	0	0	0	0	0	0	0	0
		Wake-up from Sleep and Idle mode	P	P	P	P	P	P	P	P
0x09	Bank 6 R9 P9ODCR	Bit Name	OD97	OD96	OD95	OD94	OD93	OD92	OD91	OD90
		Power-on	0	0	0	0	0	0	0	0
		/RESET and WDT	0	0	0	0	0	0	0	0
		Wake-up from Sleep and Idle mode	P	P	P	P	P	P	P	P
0x0A	Bank 6 RA PAODCR	Bit Name	ODA7	ODA6	ODA5	ODA4	ODA3	ODA2	ODA1	ODA0
		Power-on	0	0	0	0	0	0	0	0
		/RESET and WDT	0	0	0	0	0	0	0	0
		Wake-up from Sleep and Idle mode	P	P	P	P	P	P	P	P
0x0B	Bank 6 RB PBODCR	Bit Name	ODB7	ODB6	ODB5	ODB4	ODB3	ODB2	ODB1	ODB0
		Power-on	0	0	0	0	0	0	0	0
		/RESET and WDT	0	0	0	0	0	0	0	0
		Wake-up from Sleep and Idle mode	P	P	P	P	P	P	P	P
0x0C	Bank 6 RC Port C	Bit Name	1	1	1	1	RC3	RC2	RC1	RC0
		Power-on	1	1	1	1	1	1	1	1
		/RESET and WDT	1	1	1	1	1	1	1	1
		Wake-up from Sleep and Idle mode	P	P	P	P	P	P	P	P
0x10 ~ 0x3F	Bank 0 ~ Bank 7 R10~R3F	Bit Name	-	-	-	-	-	-	-	-
		Power-on	U	U	U	U	U	U	U	U
		/RESET and WDT	U	U	U	U	U	U	U	U
		Wake-up from Sleep and Idle mode	P	P	P	P	P	P	P	P

Legend: "x" = not used
 "u" = unknown or don't care

"P" = previous value before Wake-up or reset

The controller can be awakened from sleep mode and idle mode. The wake-up signals list as following.

Wake-up Signal	Sleep Mode	Idle Mode	Green Mode	Normal Mode
TCC time out	×	Wake-up + interrupt + next instruction	Interrupt	Interrupt
INT pin	Wake-up + interrupt (if enabled) + next instruction	Wake-up + interrupt(if enabled) + next instruction	Interrupt	Interrupt
Timer 1	×	Wake-up + interrupt + next instruction	Interrupt	Interrupt
Timer 2	×	Wake-up + interrupt + next instruction	Interrupt	Interrupt
UART	×	Wake-up + interrupt + next instruction	Interrupt	Interrupt
SPI	×	Wake-up + interrupt + next instruction	Interrupt	Interrupt
LVD	×	Wake-up + interrupt + next instruction	Interrupt	Interrupt
A/D	Wake-up + interrupt(if enabled) + next instruction	Wake-up + interrupt (if interrupt is enabled) + next instruction	Interrupt	Interrupt
Watch Timer	×	Wake-up + interrupt + next instruction	Interrupt	Interrupt
WDT time out	RESET	RESET	RESET	RESET

Note: User must set the wake-up register (Bank 3 RF (EIESL) Bits 2~4 and Bank 4 RF(WKCR) Bits 0~7. Wake up from INT pin or A/D in sleep and idle mode

After wake up:

1. If interrupt is enabled → interrupt + next instruction
2. If interrupt is disabled → next instruction

6.6 Oscillator

6.6.1 Oscillator Modes

The EM78P520N can be operated in the three different oscillator modes for the main oscillator (OSCI, OSCO), namely, RC oscillator with external resistor and Internal capacitor mode (IC), crystal oscillator mode, and PLL operation mode. User can select one of those three modes by programming FMMD1 and FMMD0 in the Code Option register, the sub-oscillator can be operated in crystal mode and ERIC mode. Table 3 shows how these three modes are defined.

Table 3 Oscillator Modes Defined by FSMD, FMMD1, FMMD0

FSMD	FMMD1	FMMD0	Main Clock	Sub-clock
0	0	0	RC type (ERIC)	RC type (ERIC)
0	0	1	Crystal type	RC type (ERIC)
0	1	0	PLL type	RC type (ERIC)
0	1	1	PLL type	RC type (ERIC)
1	0	0	RC type (ERIC)	Crystal type
1	0	1	Crystal type	Crystal type
1	1	0	PLL type	Crystal type
1	1	1	Crystal	None

Table 4 Summary of Maximum Operating Speeds

Conditions	VDD	Fxt max. (MHz)
Two clocks	2.0	4
	3.0	8
	5.0	16

6.6.2 Crystal Oscillator/Ceramic Resonators (Crystal)

EM78P520N can be driven by an external clock signal through the OSCO pin as shown in Figure 6-6 below.

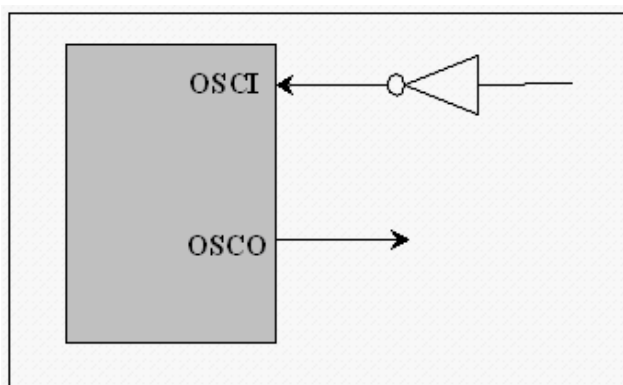

Figure 6-6 External Clock Input Circuit

In most applications, Pin OSC1 and Pin OSC0 can be connected with a crystal or ceramic resonator to generate oscillation. Figure 6-7 depicts such circuitry. Table 5 provides the recommended values of C1 and C2. Since each resonator has its own attribute, user should refer to its specification for appropriate values of C1 and C2. RS, a serial resistor, may be necessary for AT strip cut crystal or low frequency mode.

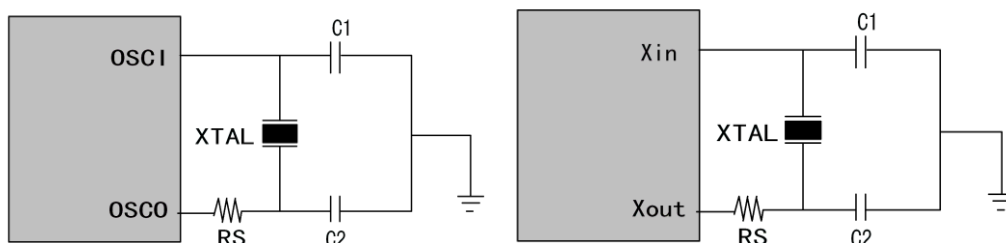

Figure 6-7-1 Circuit for Crystal/Resonator

Table 5 Capacitor Selection Guide for Crystal Oscillator or Ceramic Resonators

Oscillator Source	Oscillator Type	Frequency	C1 (pF)	C2 (pF)	
Main Oscillator	Ceramic Resonators	455kHz	30	30	
		2.0 MHz	30	30	
		4.0 MHz	30	30	
	Crystal Oscillator	100K~1 MHz	100kHz	68	68
			200kHz	30	30
			455kHz	30	30
		1M~6 MHz	1.0 MHz	30	30
			2.0 MHz	30	30
			4.0 MHz	30	30
		6M~12 MHz	6.0 MHz	30	30
			8.0 MHz	30	30
			10.0 MHz	30	30
			12.0 MHz	30	30
		12M~20 MHz	16.0 MHz	20	20
20.0 MHz	15		15		
Sub-oscillator	Crystal Oscillator	32.768kHz	40	40	

If the oscillator fails to start, the loading capacitors may need some adjustments, a higher gain oscillator mode may be selected and a resistor may be required between the OSC1 and OSC2 pins. The resistance for the feedback resistor R_F , is typically within the 1~10 M range. This varies with device voltage, temperature, and process variations. Be sure to also take into consideration the device's operating voltage and manufacturing process when determining resistor requirements.

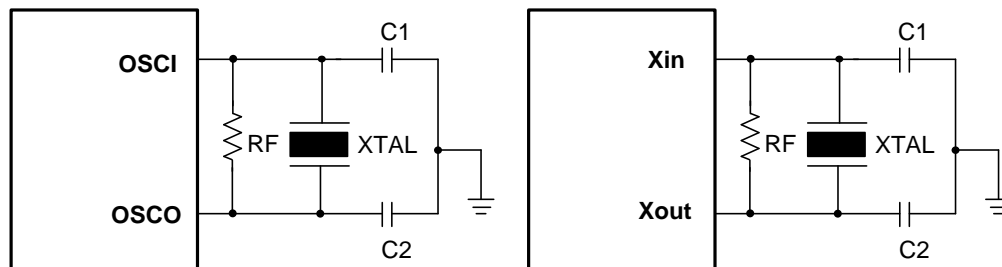

Figure 6-7-2 Circuit for Crystal/Resonator-Feedback Mode

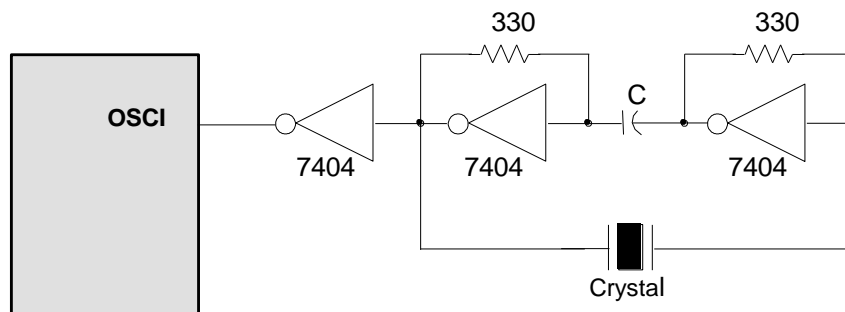

Figure 6-8 Circuit for Crystal/Resonator-Series Mode

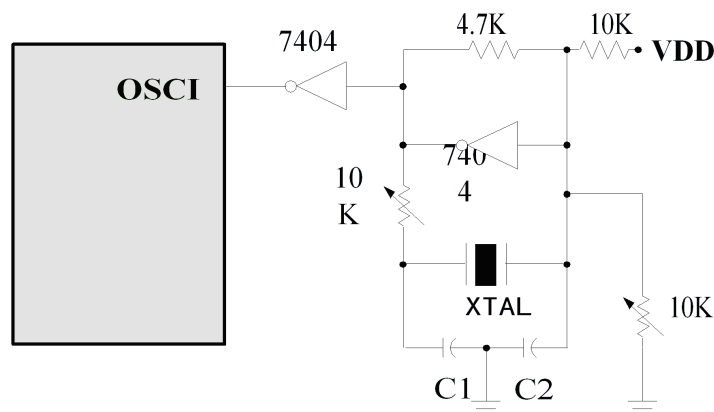

Figure 6-9 Circuit for Crystal/Resonator-Parallel Mode

6.6.3 RC Oscillator Mode with Internal Capacitor

If both precision and cost are taken into consideration, the EM78P520N also offers a special oscillation mode, which has a built-in internal capacitor and an external resistor connected to VDD. The internal capacitor functions as temperature compensator. In order to obtain more accurate frequency, a precise resistor is recommended.

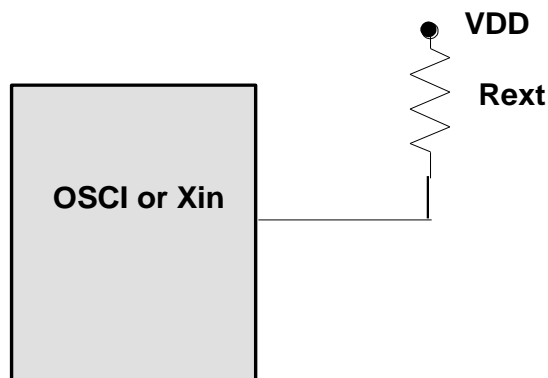

Figure 6-10 Circuit for Internal Capacitor Oscillator Mode

Table 6 Oscillator Frequencies

Pin	Rext	Average Fosc 5V, 25°C	Average Fosc 3V, 25°C
OSCI	51k	2.2221 MHz	2.1972 MHz
	100k	1.1345 MHz	1.1203 MHz
	300k	381.36kHz	374.77kHz
Xin	2.2M	32.768kHz	32.768kHz

Note: ¹: Measured based on DIP packages.

²: The values are for design reference only.

6.6.4 Phase Lock Loop (PLL Mode)

When operating in PLL mode, the High frequency is determined by the sub-oscillator. RC (Bank 0) register can be chosen to change to high oscillator frequency. The relation between high frequency (Fm) and sub-oscillator is shown on the table below:

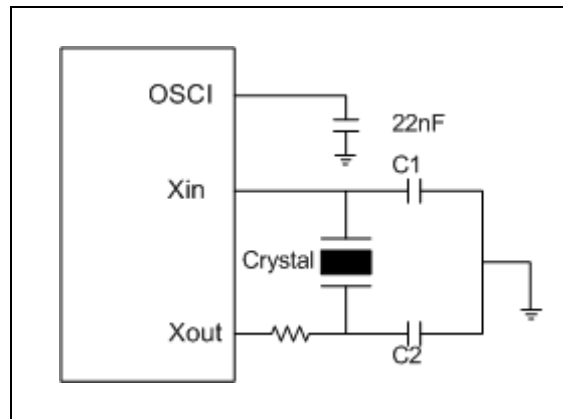

Figure 6-11 Circuit for PLL Mode

Bits 4~6 (CLK0~CLK2) of RC (Bank 0): Main Clock Selection Bits for PLL Mode
 (Code Option Select)

CLK2	CLK1	CLK0	Main Clock	Example $F_s = 32.768\text{kHz}$
0	X	X	Reserve	-
1	0	X	Reserve	-
1	1	X	$F_s \times 488$	15.99 MHz

6.7 Power-on Considerations

Any microcontroller is not warranted to start operating properly before the power supply stabilizes in its steady state. The EM78P520N has a built-in Power-on Reset (POR) with detection level range of 1.9V to 2.1V. The circuitry eliminates the extra external reset circuit. It will work well if VDD rises quickly enough (50 ms or less). However, under critical applications, extra devices are still required to assist in solving power-on problems.

6.7.1 External Power-on Reset Circuit

The circuit shown in Figure 6-12 implements an external RC to produce a reset pulse. The pulse width (time constant) should be kept long enough to allow VDD to reach minimum operation voltage. This circuit is used when the power supply has a slow rise time. Because the current leakage from the /RESET pin is $\pm 5 \mu\text{A}$, it is recommended that R should not be greater than 40K. In this way, the voltage at Pin /RESET is held below 0.2V. The diode (D) acts as a short circuit at power-down. The capacitor, C, is discharged rapidly and fully. The current-limited resistor Rin, prevents high current discharge or ESD (electrostatic discharge) from flowing into Pin /RESET.

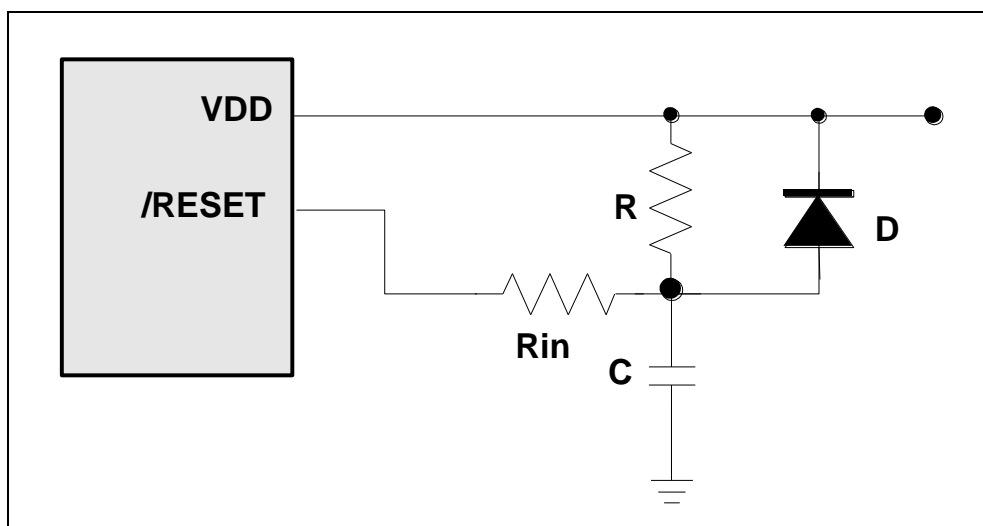

Figure 6-12 External Power-on Reset Circuit

6.7.2 Residue-Voltage Protection

When battery is replaced, device power (VDD) is taken off but residue-voltage remains. The residue-voltage may trip below Vdd minimum, but not to zero. This condition may cause a poor power-on reset. Figure 6-13 and Figure 6-14 show how to build a residue-voltage protection circuit.

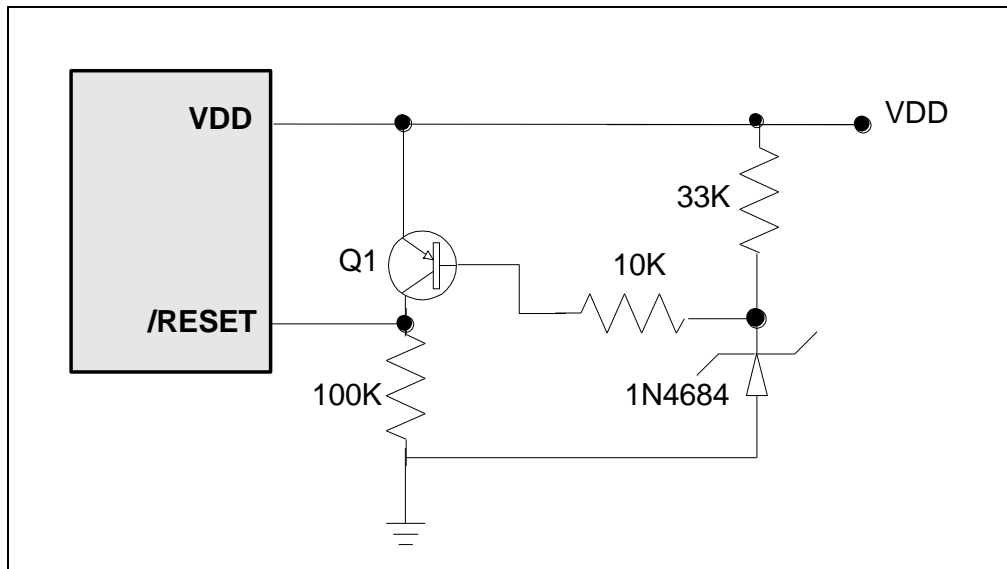

Figure 6-13 Residue Voltage Protection Circuit 1

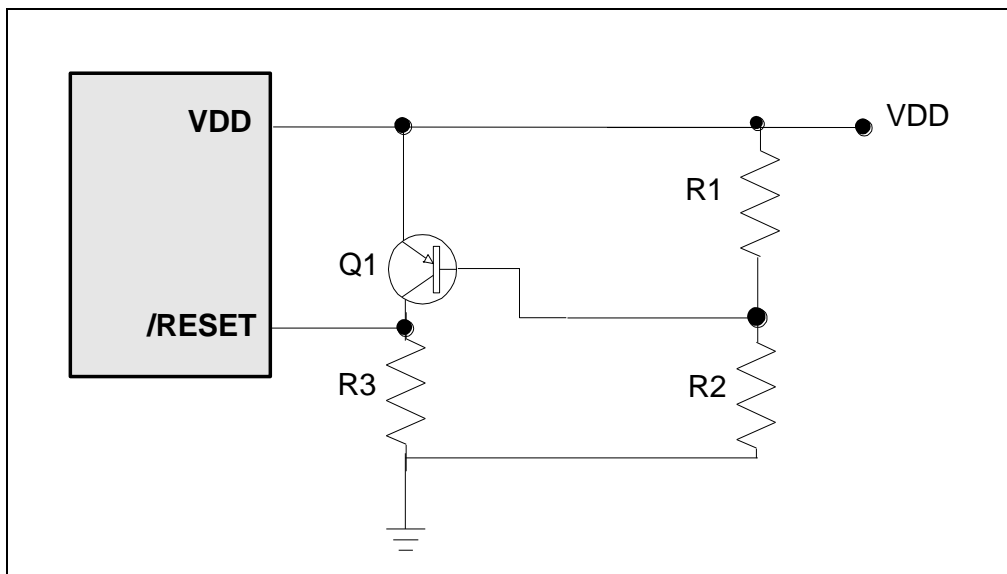

Figure 6-14 Residue Voltage Protection Circuit 2

6.8 Interrupt

Registers for Interrupt

R_BANK	Address	Name	Bit 7	Bit 6	Bit 5	Bit 4	Bit 3	Bit 2	Bit 1	Bit 0
Bank 0	0x0E	IMR	T1IE	LVDIE	ADIE	SPIIE	URTIE	EXIE9	EXIE8	TCIE
			R/W	R/W	R/W	R/W	R/W	R/W	R/W	R/W
Bank 0	0x0F	ISR	T1IF	LVDIF	ADIF	SPIIF	URTIF	EXIF9	EXIF8	TCIF
			R/W	R/W	R/W	R/W	R/W	R/W	R/W	R/W
Bank 1	0X0E	EIMR	EXIE7	EXIE6	EXIE5	EXIE4	EXIE3	EXIE2	EXIE1	EXIE0
			R/W	R/W	R/W	R/W	R/W	R/W	R/W	R/W
Bank 1	0X0F	EISR	EXIF7	EXIF6	EXIF5	EXIF4	EXIF3	EXIF2	EXIF1	EXIF0
			R/W	R/W	R/W	R/W	R/W	R/W	R/W	R/W
Bank 2	0X09	T2CR	T2IF	T2IE	T2S	T2MS1	T2MS0	T2P2	T2P1	T2P0
			R/W	R/W	R/W	R/W	R/W	R/W	R/W	R/W

The EM78P520N has ten interrupt sources as listed below:

- TCC overflow interrupt
- External interrupt pin
- Watch timer interrupt
- Timer 1 overflow interrupt
- Timer 2 overflow interrupt
- A/D conversion complete interrupt
- UART transmit/receive/error interrupt
- SPI transmit/receive interrupt
- Low voltage detector

This IC has internal interrupts which are falling edge triggered, namely: TCC timer overflow interrupt, and two 8-bit upper counter/timer overflow interrupt. If these interrupt sources change signal from high to low, the RF register will generate a “1” flag to the corresponding register if RE register is enabled.

RF is the interrupt status register which records the interrupt request in flag bit. RE is the interrupt mask register. Global interrupt is enabled by ENI instruction and is disabled by DISI instruction. When one of the interrupts (when enabled) is generated, it will cause the next instruction to be fetched from Address 0003H~001BH according to the interrupt source.

For EM78P520N, each individual interrupt source has its own interrupt vector as depicted in Table 7.

Before the interrupt subroutine is executed, the contents of ACC, R3[4:0] and the R5 register will be saved by hardware. After the interrupt service routine is finished, ACC, R3[4:0] and R5 will be pushed back. While in interrupt service routine, other interrupt service routine should not be allowed to be executed, so if other interrupts occur in an interrupt service routine, the hardware will save this interrupt, after which when interrupt service routine is completed, the next interrupt service routine will be executed.

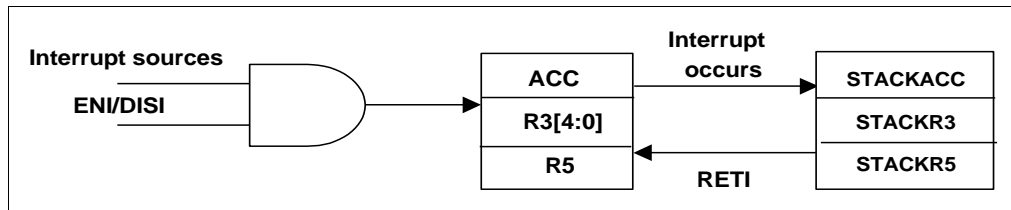

Figure 6-15 Interrupt Backup Diagram

Table 7 Interrupt Vector

Interrupt Vector	Interrupt Status
0003H	TCC overflow interrupt
0006H	External interrupt
0009H	Watch timer interrupt
000CH	Timer 1 overflow interrupt
000FH	Timer 2 overflow interrupt
0012H	A/D conversion complete interrupt
0015H	UART transmit/receive/error complete interrupt
0018H	SPI transmit/receive complete interrupt
001BH	Low voltage detector interrupt

6.9 LCD Driver

Registers for LCD Driver Circuit

R_BANK	Address	Name	Bit 7	Bit 6	Bit 5	Bit 4	Bit 3	Bit 2	Bit 1	Bit 0
Bank 1	0x05	LCDCR	LCDEN	LCDTYPE	BS1	BS0	DS1	DS0	LCDF1	LCDF0
			R/W	R/W	R/W	R/W	R/W	R/W	R/W	R/W
Bank 1	0x06	LCDAR	-	-	-	LCD_A4	LCD_A3	LCD_A2	LCD_A1	LCD_A0
			-	-	-	R/W	R/W	R/W	R/W	R/W
Bank 1	0x07	LCDBR	LCD_D7	LCD_D6	LCD_D5	LCD_D4	LCD_D3	LCD_D2	LCD_D1	LCD_D0
			R/W	R/W	R/W	R/W	R/W	R/W	R/W	R/W
Bank 1	0x08	LCDVCR	-	-	-	LCDC1	LCDC0	LCDVC2	LCDVC1	LCDVC0
			-	-	-	R/W	R/W	R/W	R/W	R/W
Bank 1	0x09	LCDCCR	CON7	CON6	CON5	CON4	CON3	CON2	CON1	CON0
			R/W	R/W	R/W	R/W	R/W	R/W	R/W	R/W
Bank 1	0x0A~0x0C	LCDSCR0~2	SEG	SEG	SEG	SEG	SEG	SEG	SEG	SEG
			R/W	R/W	R/W	R/W	R/W	R/W	R/W	R/W

The EM78P520N can drive an LCD with up to 23 segments and 8 commons that can drive a total of 8×23 dots. LCD block is made up of LCD driver, display RAM, segment output pins, common output pins and LCD operating power supply pins. This circuit can work in normal mode, green mode and idle mode.

The LCD duty, bias, the number of segment, the number of common and frame frequency are determined by the LCD controller register.

The basic structure contains a timing control which use the main system clock or subsystem clock to generate the proper timing for different duty and display access. The R5 register is a command register for LCD driver that include LCD enable/disable, bias (1/2, 1/3 and 1/4), duty (Static, 1/3, 1/4, 1/8) and LCD frame frequency control. The register Bank 1 R6 is an LCD RAM address control register. The register Bank 1 R7 is an LCD RAM data buffer. The register Bank 1 R8 is an LCD contrast control and LCD clock register. The control register is explained below.

6.9.1 R5 LCDCR (LCD Control Register)

Bit 7	Bit 6	Bit 5	Bit 4	Bit 3	Bit 2	Bit 1	Bit 0
LCDEN	LCDTYPE	BS1	BS0	DS1	DS0	LCDF1	LCDF0

Bit 7 (LCDEN): LCD Enable Select Bit

0 : Disable LCD Circuit. All common/segment outputs are set to VDD Level.

1 : Enable LCD circuit

Bit 6 (LCDTYPE): LCD Drive Waveform Type Select Bit

0 : A type wave

1 : B type wave

Bits 5~4 (BS1~BS0): LCD Bias Select Bits

BS1	BS0	LCD Bias Select
0	0	1/2 Bias
0	1	1/3 Bias
1	×	1/4 Bias

Bits 3~2 (DS1~DS0): LCD Duty Select Bits

DS1	DS0	LCD Duty
0	0	Static
0	1	1/3 Duty
1	0	1/4 Duty
1	1	1/8 Duty

Bits 1~0 (LCDF1~LCDF0): LCD Frame Frequency Control Bits

LCD Frame Frequency (e.g. $F_s = 32.768K$)					
LCDF1	LCDF0	Static	1/3 Duty	1/4 Duty	1/8 Duty
0	0	$F_s/(512 \times 1) = 64.0$	$F_s/(172 \times 3) = 63.5$	$F_s/(128 \times 4) = 64$	$F_s/(64 \times 8) = 64.0$
0	1	$F_s/(560 \times 1) = 58.5$	$F_s/(188 \times 3) = 58$	$F_s/(140 \times 4) = 58.5$	$F_s/(70 \times 8) = 58.5$
1	0	$F_s/(608 \times 1) = 53.9$	$F_s/(204 \times 3) = 53.5$	$F_s/(152 \times 4) = 53.9$	$F_s/(76 \times 8) = 53.9$
1	1	$F_s/(464 \times 1) = 70.6$	$F_s/(156 \times 3) = 70$	$F_s/(116 \times 4) = 70.6$	$F_s/(58 \times 8) = 70.6$

6.9.2 R6 LCDADDR (LCD Address Register)

Bit 7	Bit 6	Bit 5	Bit 4	Bit 3	Bit 2	Bit 1	Bit 0
0	0	0	LCD_A4	LCD_A3	LCD_A2	LCD_A1	LCD_A0

Bits 7~5: Reserved

Bits 4~0 (LCD_A4~LCD_A0): LCD RAM Address

R6 (LCD Address)	R7 (LCD Data Buffer)								Segment
	Bit 7 (LCD_D7)	Bit 6 (LCD_D6)	Bit 5 (LCD_D5)	Bit 4 (LCD_D4)	Bit 3 (LCD_D3)	Bit 2 (LCD_D2)	Bit 1 (LCD_D1)	Bit 0 (LCD_D0)	
00H									SEG0
01H									SEG1
02H									SEG2
14H									SEG20
15H									SEG21
16H									SEG22
Common	COM7	COM6	COM5	COM4	COM3	COM2	COM1	COM0	

6.9.3 R7 LCDBR (LCD Data Buffer)

Bit 7	Bit 6	Bit 5	Bit 4	Bit 3	Bit 2	Bit 1	Bit 0
LCD_D7	LCD_D6	LCD_D5	LCD_D4	LCD_D3	LCD_D2	LCD_D1	LCD_D0

Bits 7~0 (LCD_D7~LCD_D0): LCD RAM Data Transfer Register

* When the value of the display segment is "1", the LCD display is turned on; when the bit value is "0", the LCD display is turned off.

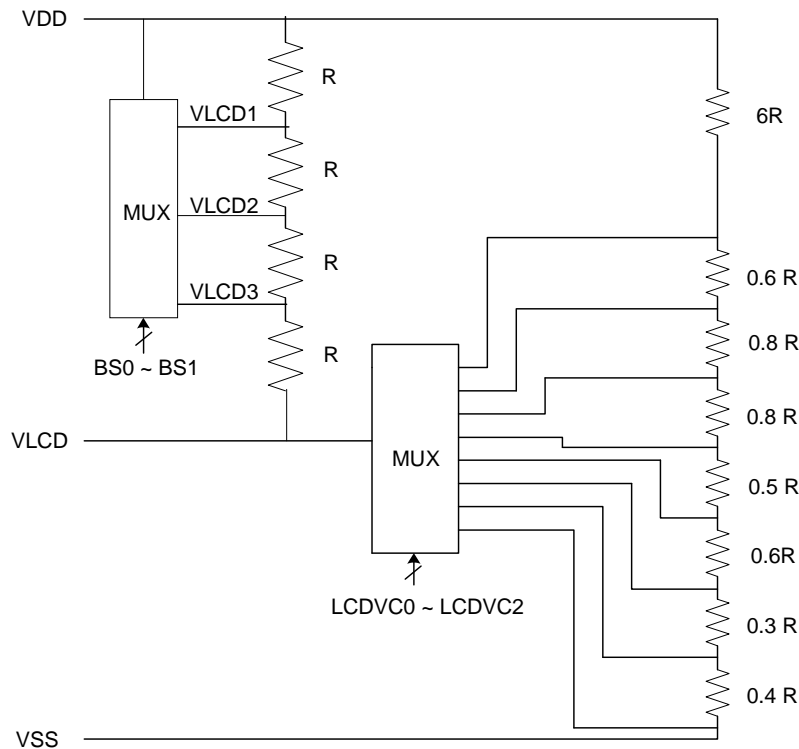

6.9.4 R8 LCDVCR (LCD Voltage Control Register)

Bit 7	Bit 6	Bit 5	Bit 4	Bit 3	Bit 2	Bit 1	Bit 0
0	0	0	LCDC1	LCDC0	LCDVC2	LCDVC1	LCDVC0

Bits 7~5: Reserved

Bits 4~3 (LCDC1~LCDC0): LCD Clock

LCDC1	LCDC0	F _m	F _{LCD}
0	0	16 MHz	F _c /2 ⁹
0	1	8 MHz	F _c /2 ⁸
1	0	4 MHz	F _c /2 ⁷
1	1	2 MHz	F _c /2 ⁶

When the main oscillator operates in crystal mode and there is no sub-oscillator, it is a must to set these two bits used for LCD clock.

Bits 2~0 (LCDVC2~LCDVC0): LCD Voltage Control Bits

LCDVC2	LCDVC1	LCDVC0	Output
0	0	0	0.4VDD ~ VDD
0	0	1	0.34VDD ~ VDD
0	1	0	0.26VDD ~ VDD
0	1	1	0.18VDD ~ VDD
1	0	0	0.13VDD ~ VDD
1	0	1	0.07VDD ~ VDD
1	1	0	0.04VDD ~ VDD
1	1	1	0V ~ VDD

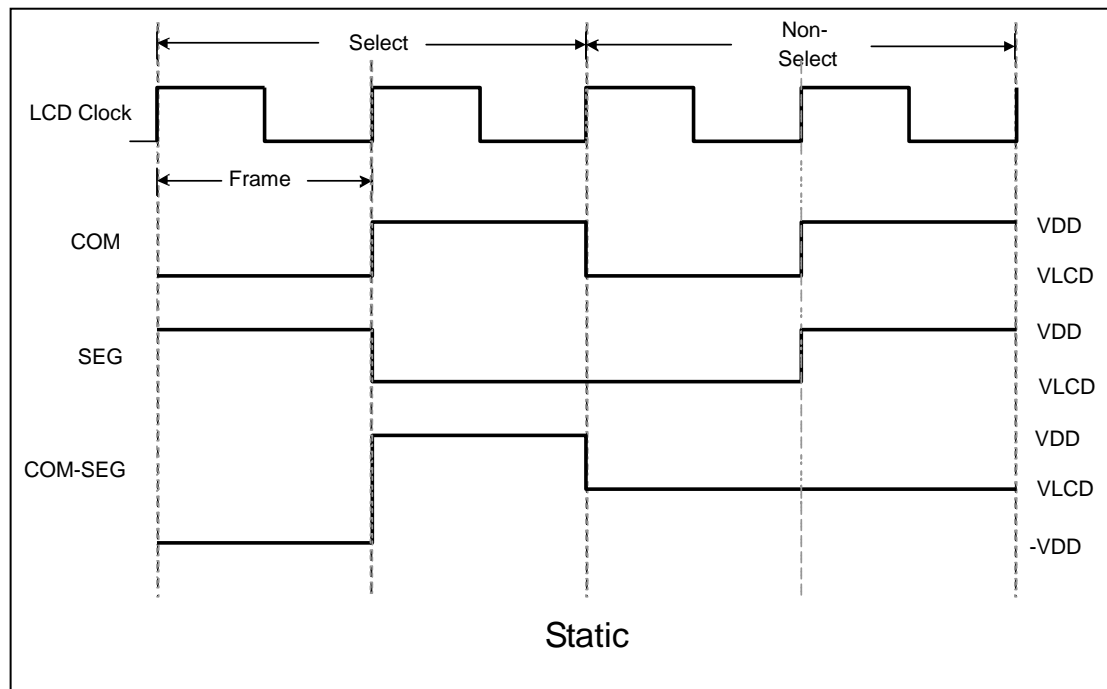

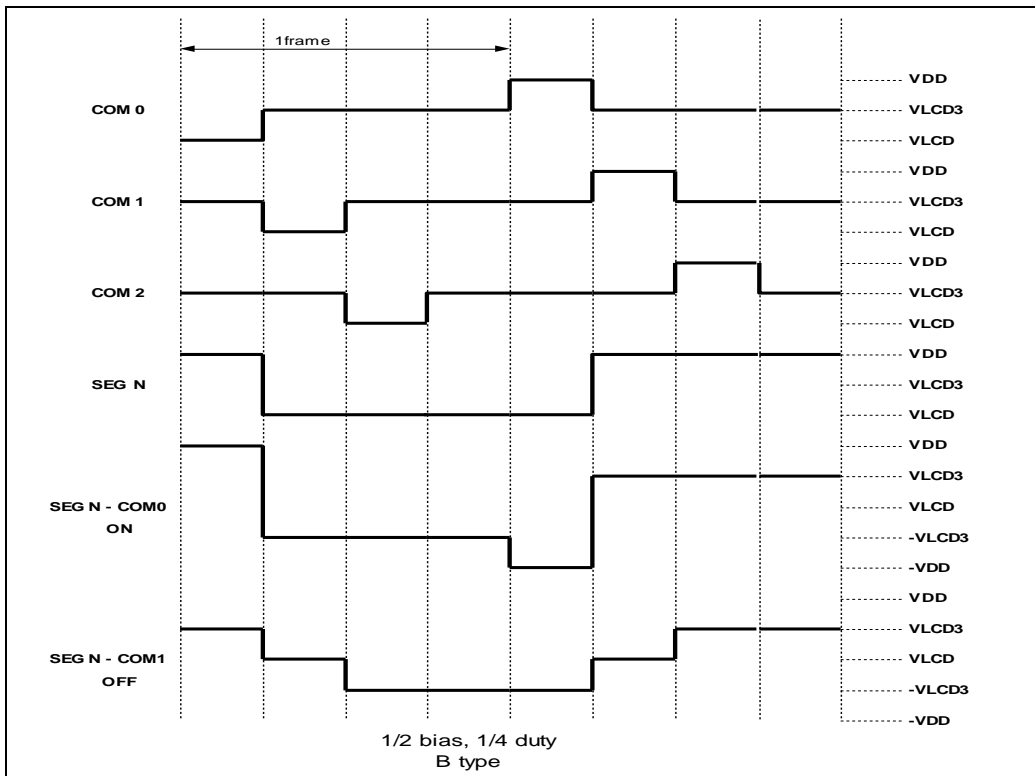
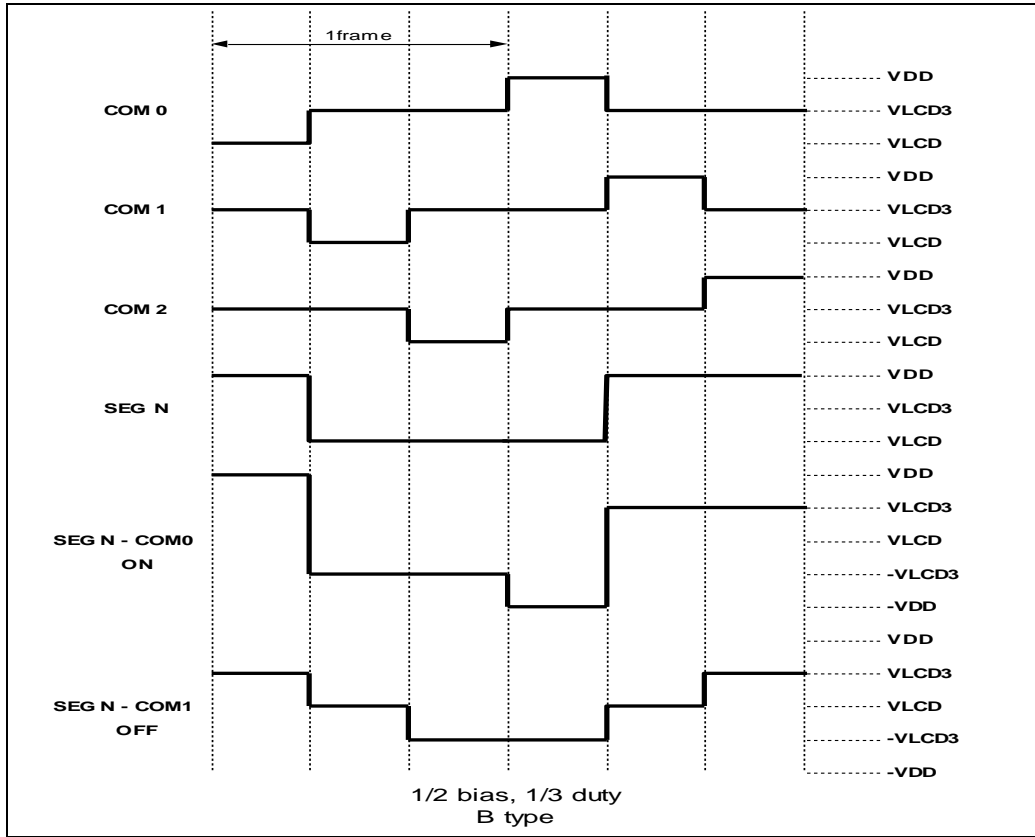

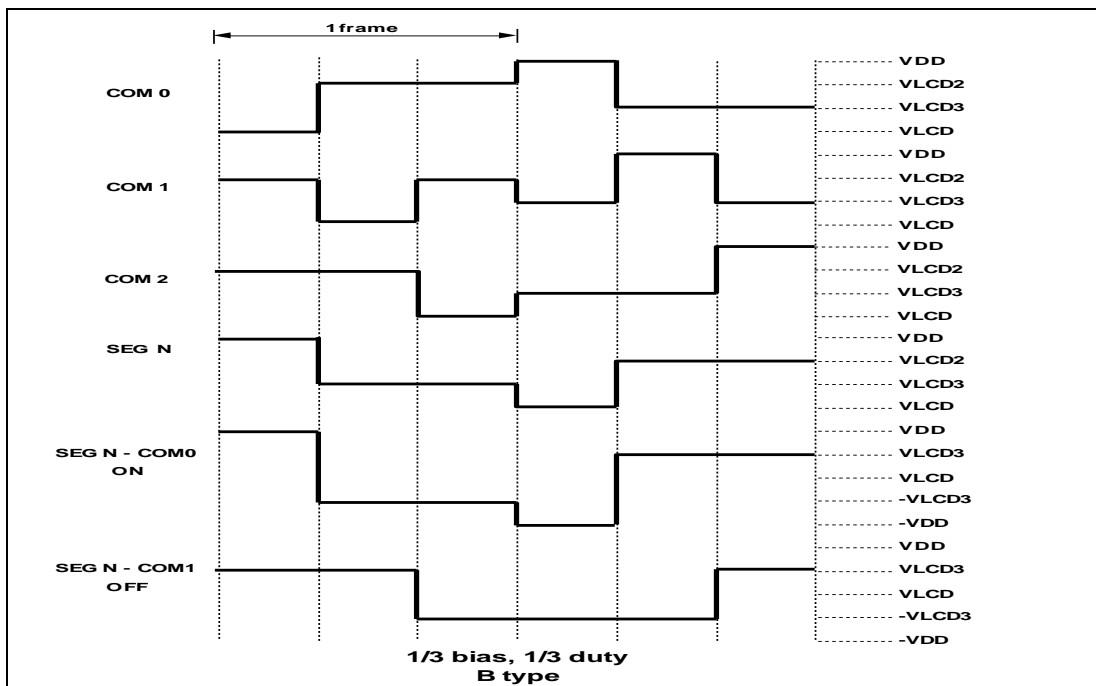
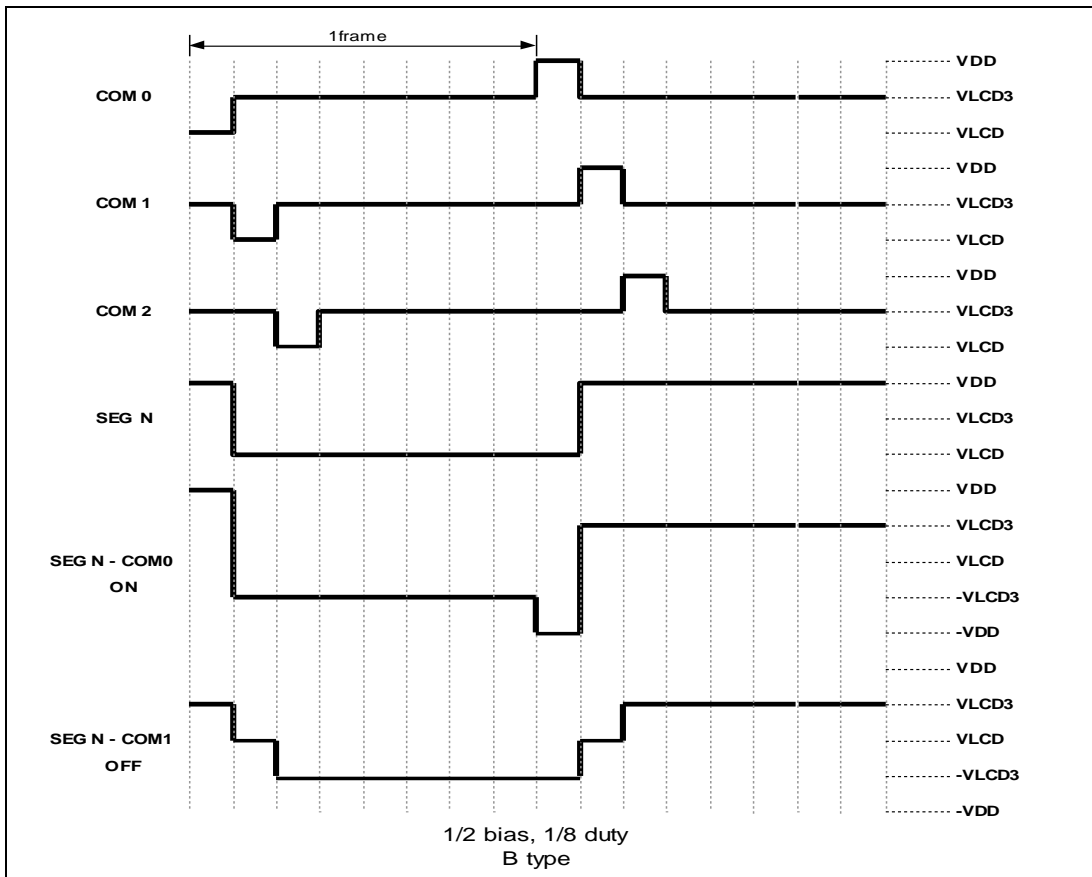

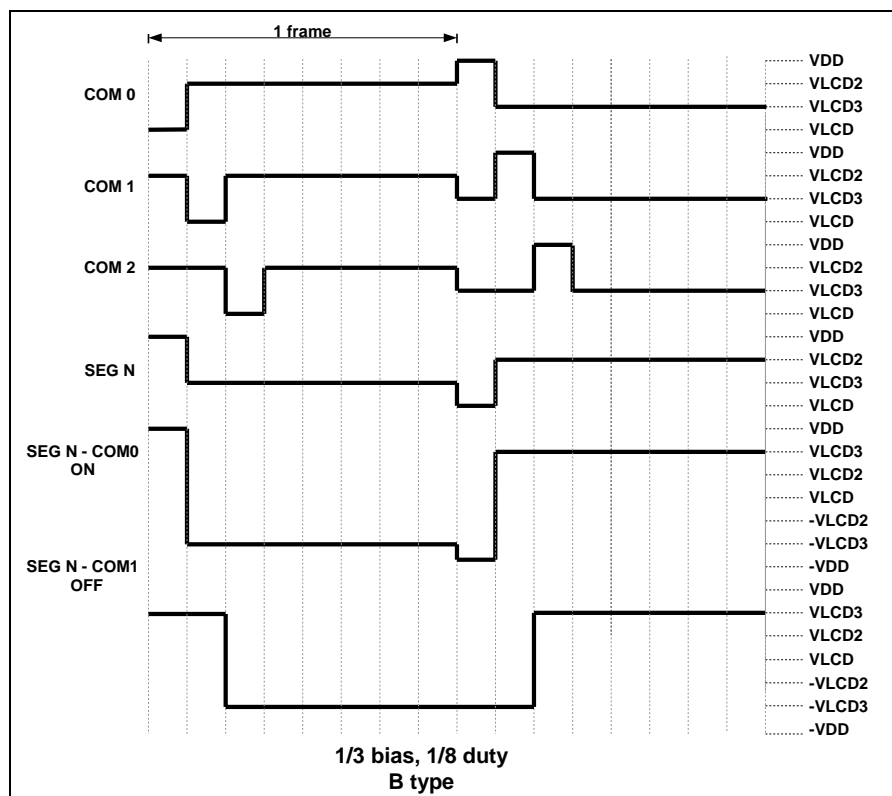
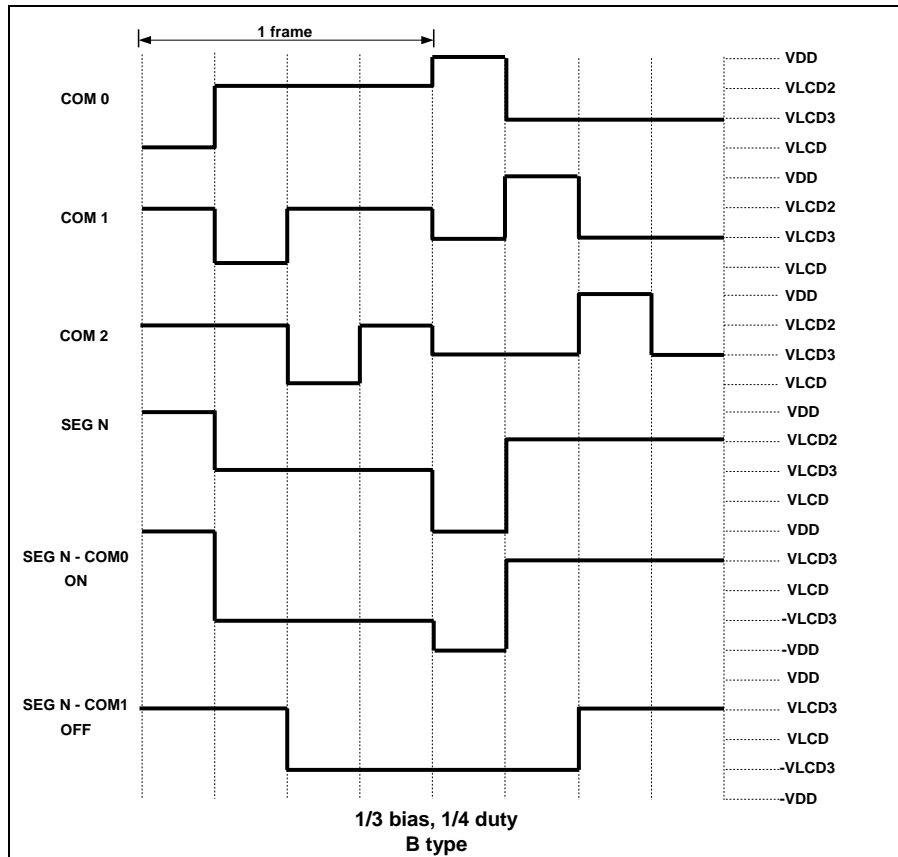

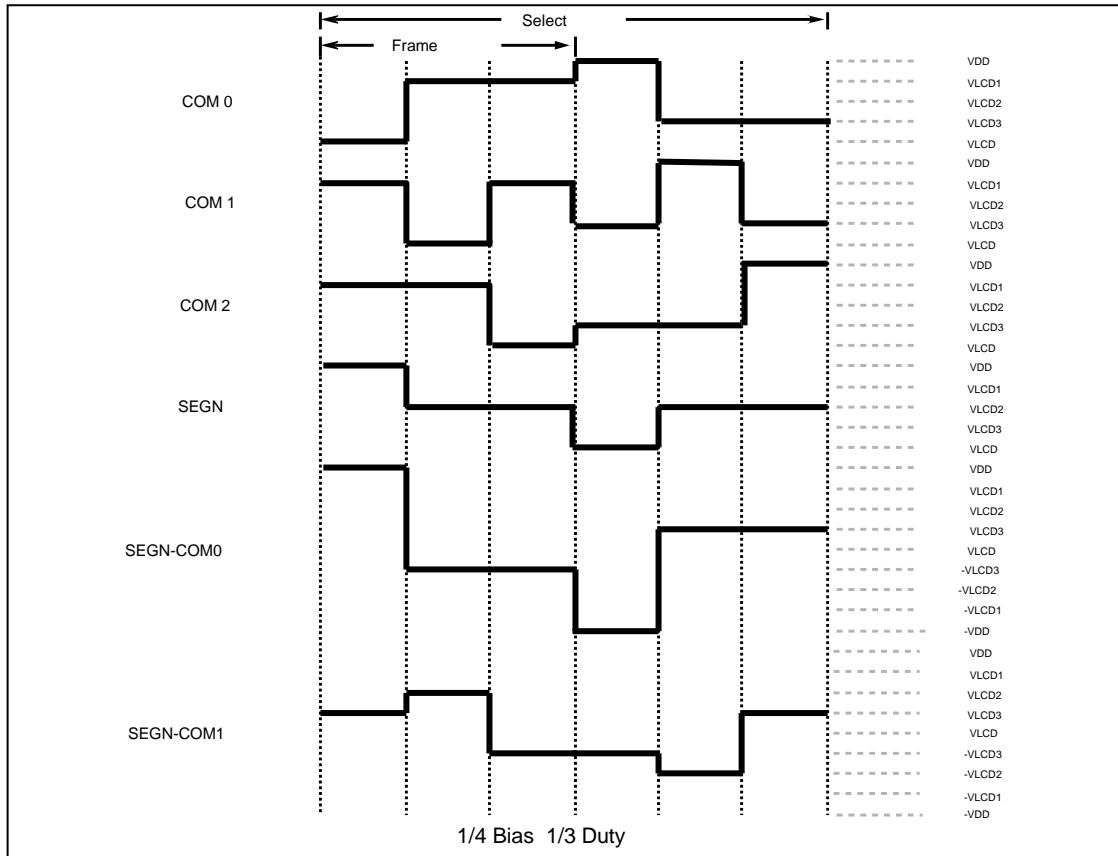

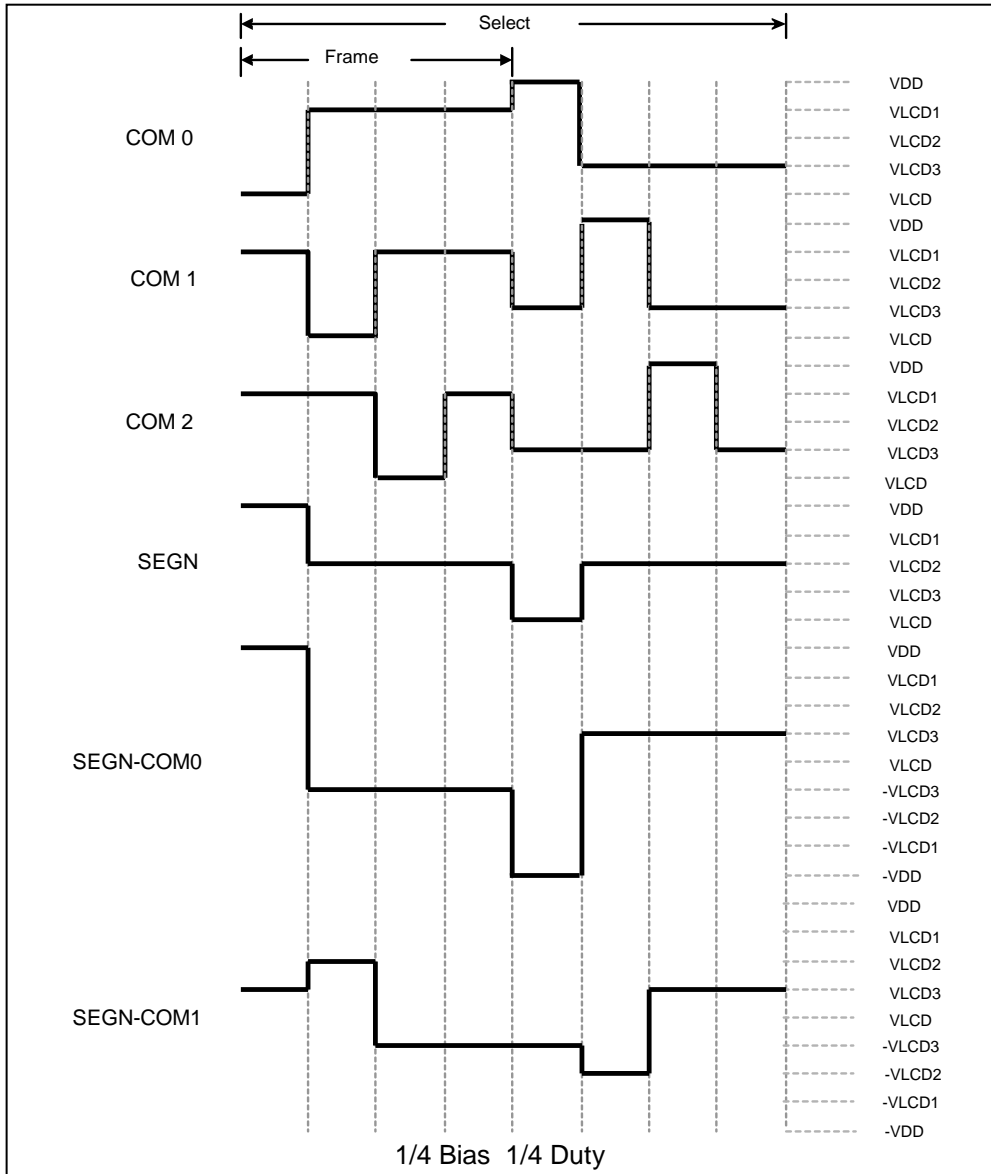

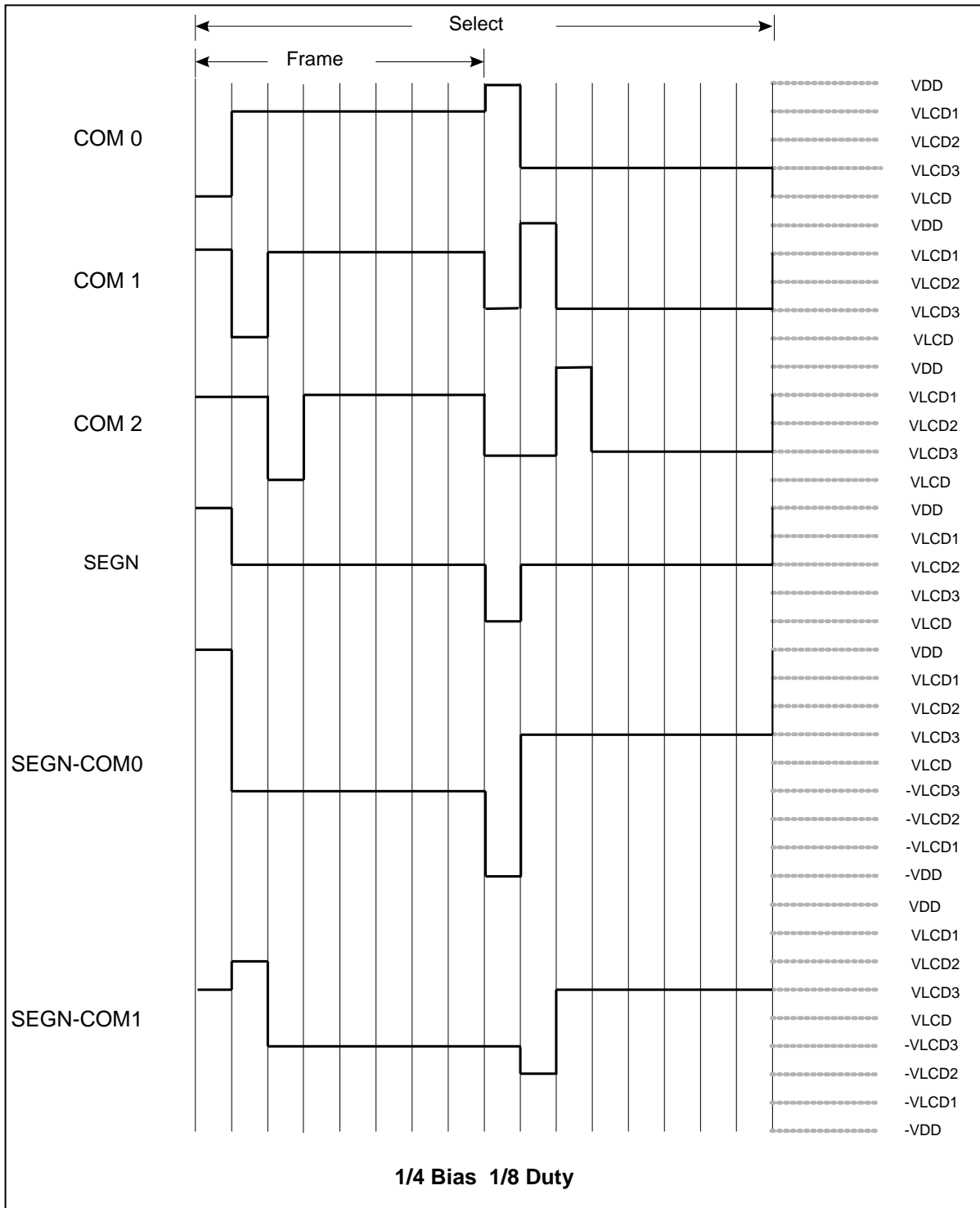

6.10 A/D Converter

Registers for AD Converter Circuit

R_BANK	Address	Name	Bit 7	Bit 6	Bit 5	Bit 4	Bit 3	Bit 2	Bit 1	Bit 0
Bank 3	0X09	ADCR	ADRUN	ADP	ADCK1	ADCK0	ADIS3	ADIS2	ADIS1	ADIS0
			R/W	R/W	R/W	R/W	R/W	R/W	R/W	R/W
Bank 3	0x0A	ADICH	CALI	ADREF			ADE11	ADE10	ADE9	ADE8
			R/W	R/W			R/W	R/W	R/W	R/W
Bank 3	0X0B	ADICL	ADE7	ADE6	ADE5	ADE4	ADE3	ADE2	ADE1	ADE0
			R/W	R/W	R/W	R/W	R/W	R/W	R/W	R/W
Bank 3	0X0C	ADDH	ADD11	ADD10	ADD9	ADD8	ADD7	ADD6	ADD5	ADD4
			R	R	R	R	R	R	R	R
Bank 3	0X0D	ADDL	SIGN	VOF[2]	VOF[1]	VOF[0]	ADD3	ADD2	ADD1	ADD0
			R/W	R/W	R/W	R/W	R	R	R	R
Bank 0	0x0F	EIESL				ADWK	INTWK	INTWK	EIES9	EIES8
						R/W	R/W	R/W	R/W	R/W
Bank 0	0x0E	IMR	T1IE	LVDIE	ADIE	SPIIE	URTIE	EXIE9	EXIE8	TCIE
			R/W	R/W	R/W	R/W	R/W	R/W	R/W	R/W
Bank 0	0x0F	ISR	T1IF	LVDIF	ADIF	SPIIF	URTIF	EXIF9	EXIF8	TCIF
			R/W	R/W	R/W	R/W	R/W	R/W	R/W	R/W

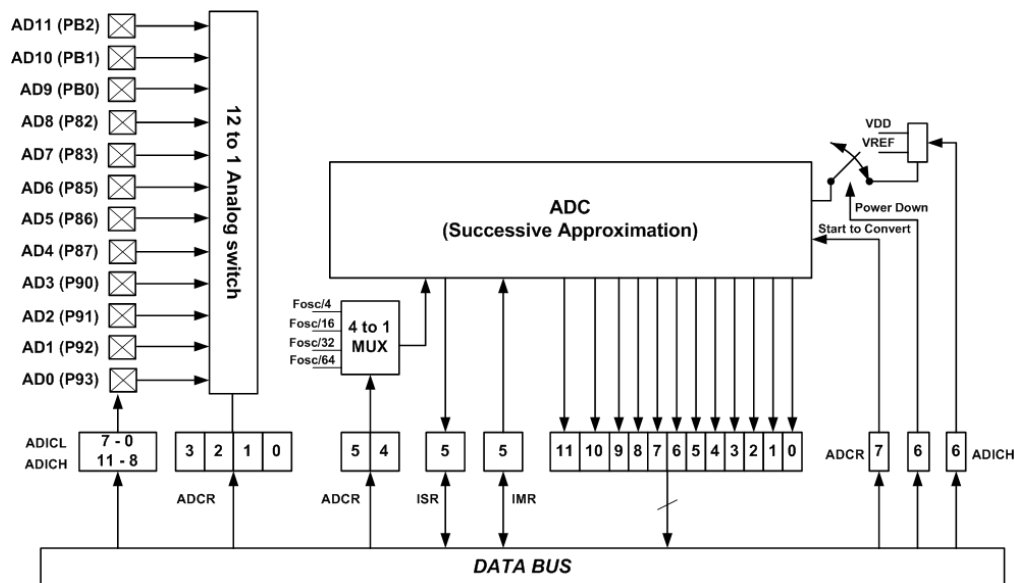

Figure 6-16 AD Converter

This is a 12-bit successive approximation type AD converter. The upper side of analog reference voltage can select either internal VDD or external input pin P84 (VREF) by setting the ADREF bit in ADICH. Connecting to the external VREF is more accurate than connecting to the internal VDD.



6.10.1 ADC Data Register

When A/D conversion is completed, the result is loaded to the ADDH (8-bit) and ADDL (4-bit). The START/END bit is cleared, and the ADIF is set.

6.10.2 A/D Sampling Time

The accuracy, linearity, and speed of the successive approximation A/D converter are dependent on the properties of the ADC. The source impedance and the internal sampling impedance directly affect the time required to charge the sample holding capacitor. The application program controls the length of the sample time to meet the specified accuracy. Generally speaking, the program should wait for 2 μ s for each K Ω of the analog source impedance and at least 2 μ s for the low-impedance source. The maximum recommended impedance for the analog source is 10K Ω at VDD =5V. After the analog input channel is selected, this acquisition time must be done before A/D conversion can be started.

6.10.3 A/D Conversion Time

ADCK0 and ADCK1 select the conversion time (Tct), in terms of instruction cycles. This allows the MCU to run at maximum frequency without sacrificing accuracy of A/D conversion. For the EM78P520N, the conversion time per bit is about 4 μ s. Table 8 shows the relationship between Tct and the maximum operating frequencies.

Table 8

ADCK1:0	Operation Mode	Max. Frequency (Fc)	Max. Conversion Rate per Bit	Max. Conversion Rate
0 0	Fc/4	1 MHz	250kHz (4 μ s)	60 μ s (16.66kHz)
0 1	Fc/16	4 MHz	250kHz (4 μ s)	60 μ s (16.66kHz)
1 0	Fc/32	8 MHz	250kHz (4 μ s)	60 μ s (16.66kHz)
1 1	Fc/64	16 MHz	250kHz (4 μ s)	60 μ s (16.66kHz)

6.11 UART (Universal Asynchronous Receiver/Transmitter)

Registers for UART Circuit

R_BANK	Address	Name	Bit 7	Bit 6	Bit 5	Bit 4	Bit 3	Bit 2	Bit 1	Bit 0
Bank 3	0X05	URC	URTD8	UMODE1	UMODE0	BRATE2	BRATE1	BRATE0	UTBE	TXE
			W	R/W	R/W	R/W	R/W	R/W	R	R/W
Bank 3	0X06	URS	URRD8	EVEN	PRE	PRERR	OVERR	FMERR	URBF	RXE
			R	R/W	R/W	R	R	R	R	R/W
Bank 3	0X07	URRD	URRD7	URRD6	URRD5	URRD4	URRD3	URRD2	URRD1	URRD0
			R	R	R	R	R	R	R	R
Bank 3	0X08	URTD	URTD 7	URTD 6	URTD 5	URTD 4	URTD 3	URTD 2	URTD 1	URTD0
			W	W	W	W	W	W	W	W
Bank 5	0x06	UARC2			UARTE		UINVEN			
					R/W		R/W			
Bank 0	0x0E	IMR	T1IE	LVDIE	ADIE	SPIIE	URTIE	EXIE9	EXIE8	TCIE
			R/W	R/W	R/W	R/W	R/W	R/W	R/W	R/W
Bank 0	0x0F	ISR	T1IF	LVDIF	ADIF	SPIIF	URTIF	EXIF9	EXIF8	TCIF
			R/W	R/W	R/W	R/W	R/W	R/W	R/W	R/W

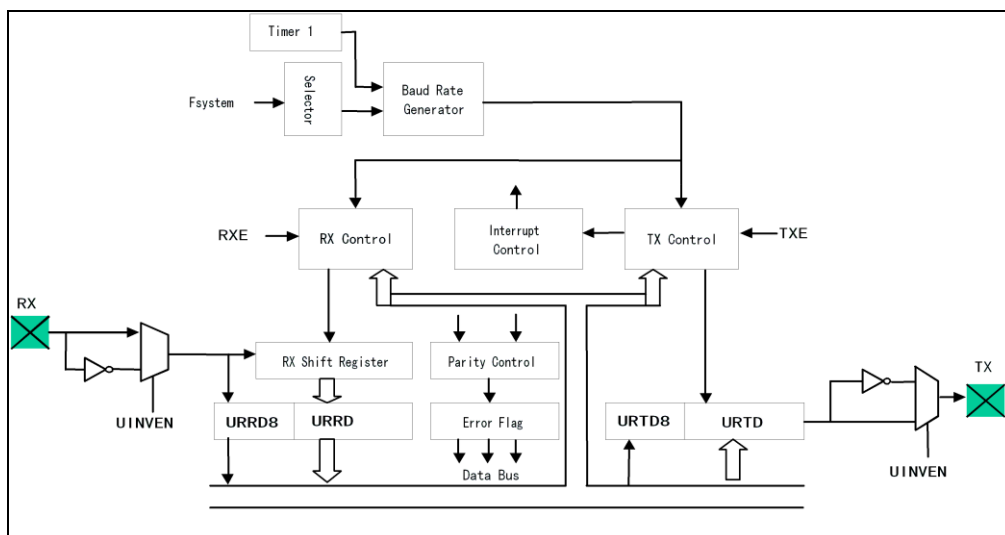

Figure 6-17 Functional Block Diagram

In Universal Asynchronous Receiver Transmitter (UART), each transmitted or received character is individually synchronized by framing it with a start bit and stop bit.

Full duplex data transfer is possible since the UART has independent transmit and receive sections. Double buffering for both sections allows the UART to be programmed for continuous data transfer.

The figure below shows the general format of one character sent or received. The communication channel is normally held in the marked state (high). Character transmission or reception starts with a transition to the space state (low).

The first bit transmitted or received is the start bit (low). It is followed by the data bits, in which the Least Significant Bit (LSB) comes first. The data bits are followed by the parity bit. If present, then the stop bit or bits (high) confirm the end of the frame.

In receiving, the UART synchronizes on the falling edge of the start bit. When two or three "0" are detected during three samples, it is recognized as normal start bit and the receiving operation is started.

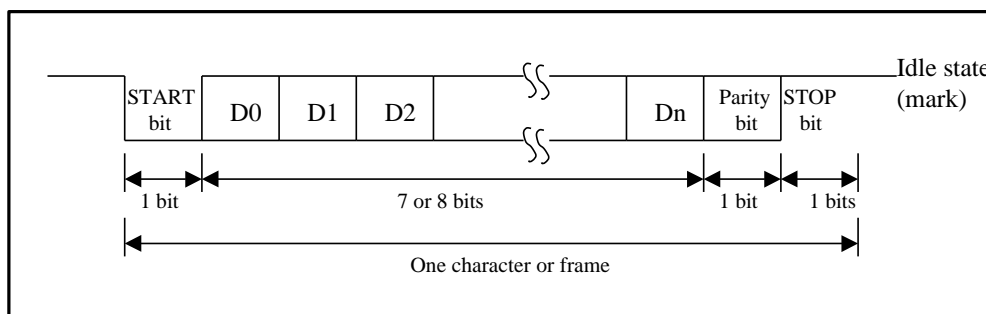

Figure 6-18 Data Format in UART

6.11.1 UART Mode

There are three UART modes. Mode 1 (7 bits data) and Mode 2 (8 bits data) allow the addition of a parity bit. The parity bit addition is not available in Mode 3. Figure 6-19 below shows the data format in each mode.

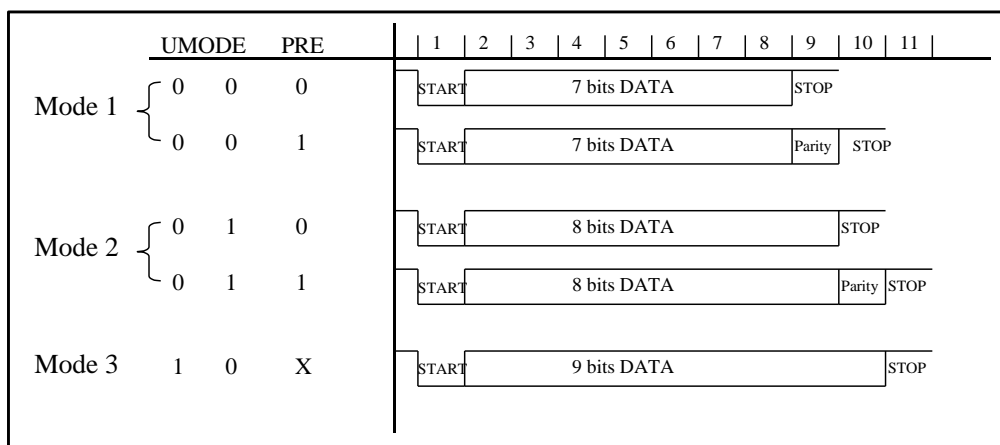

Figure 6-19 UART Model

6.11.2 Transmitting

In transmitting serial data, the UART operates as follows:

1. Set the TXE bit of the URC register to enable the UART transmission function.
2. Write data into the URTD register and the UTBE bit of the URC register will be set by hardware.
3. Then start transmitting.
4. Serially transmitted data are transmitted in the following order from the TX pin.
5. Start bit: one “0” bit is output.
6. Transmit data: 7, 8 or 9 bits data are output from the LSB to the MSB.
7. Parity bit: one parity bit (odd or even selectable) is output.
8. Stop bit: one “1” bit (stop bit) is output.

Mark state: output “1” continues until the start bit of the next transmitted data.

After transmitting the stop bit, the UART generates a TBEF interrupt (if enabled).

6.11.3 Receiving

In receiving, the UART operates as follows:

1. Set RXE bit of the URS register to enable the UART receiving function. The UART monitors the RX pin and synchronizes internally when it detects a start bit.
2. Receive data is shifted into the URRD register in the order from LSB to MSB.
3. The parity bit and the stop bit are received. After one character is received, the URBF bit of the URS register will be set to “1”.
4. The UART makes the following checks:
 - (a) Parity check: The number 1 of the received data must match the even or odd parity setting of the EVEN bit in the URS register.
 - (b) Frame check: The start bit must be “0” and the stop bit must be “1”.
 - (c) Overrun check: The URBF bit of the URS register must be cleared (that means the URRD register should be read out) before the next received data is loaded into the URRD register.

If any checks failed, the URTIF interrupt will be generated (if enabled), and an error flag is indicated in PRERR, OVERR or FMERR bit. The error flag should be cleared by software otherwise, URTIF interrupt will occur when the next byte is received.

5. Read received data from the URRD register. The URBF bit will be cleared by hardware.

6.11.4 Baud Rate Generator

The baud rate generator is comprised of a circuit that generates a clock pulse to determine the transfer speed for transmission/reception in the UART.

The BRATE2~BRATE0 bits of the URC register can determine the desired baud rate.

6.11.5 UART Timing

1. Transmission Counter Timing

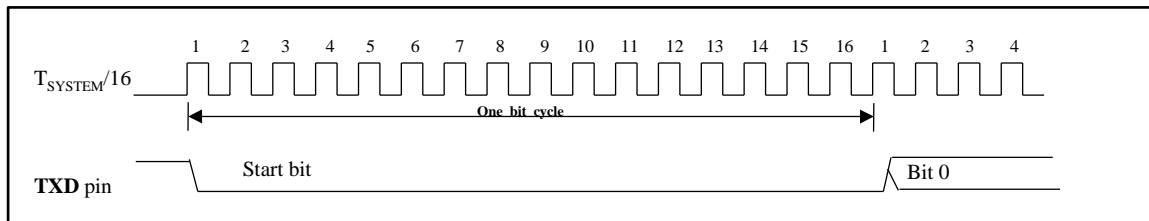

2. Receiving Counter Timing

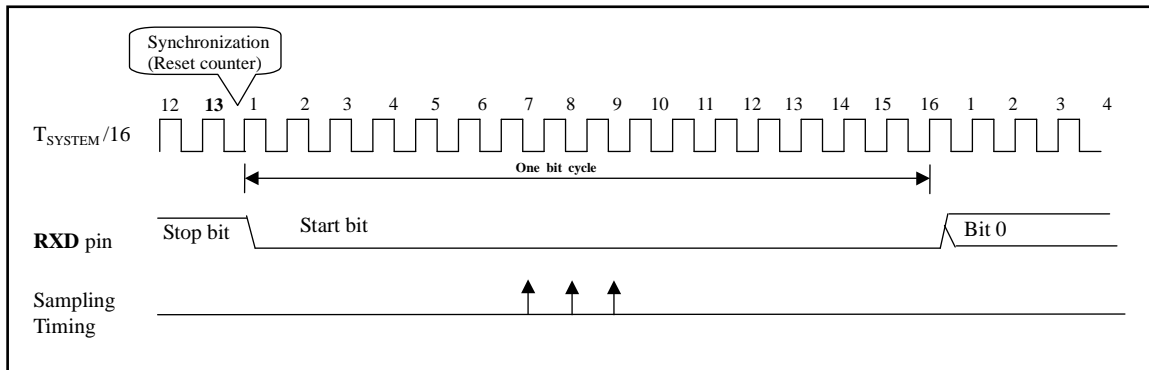

3. UART Transmit operation (8 bits data with parity bit)

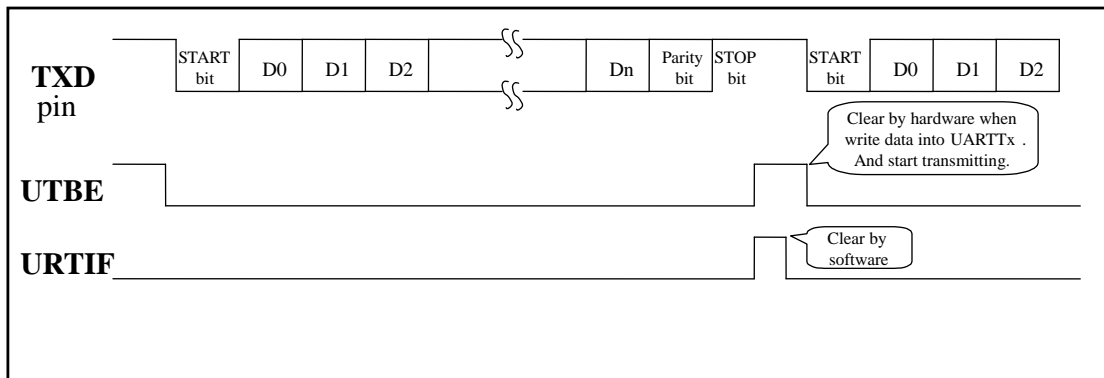

4. UART Receive operation (8 bits data with parity and stop bit):

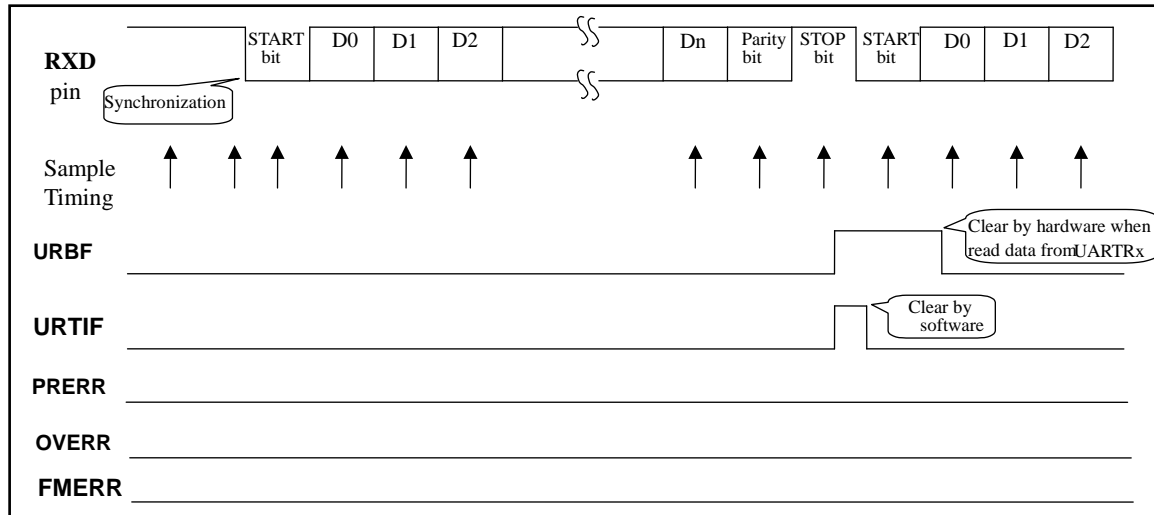

6.12 SPI (Serial Peripheral Interface)

6.12.1 Overview and Features

Overview:

Figures 6-20 and 6-21 shows how the EM78P520N communicates with other devices through SPI module. If the EM78P520N is a master controller, it sends clock through the SCK pin. A couple of 8-bit data are transmitted and received at the same time. However, if the EM78P520N is defined as a slave, its SCK pin could be programmed as an input pin. Data will continue to be shifted based on both the clock rate and the selected edge. The SPIS Bit 7 (DORD) can also set to determine the SPI transmission order, SPIC Bit 3 (SDOC) to control the SO pin after serial data output status and SPIS Bit 6 (TD1), Bit 5 (TD0) determines the SO status output delay times.

Features:

- Operation in either Master mode or Slave mode
- Full duplex, three-wire synchronous communication
- Programmable baud rates of communication
- Programming clock polarity, (RD Bit 7)
- Interrupt flag available for the read buffer full
- SPI transmission order
- After serial data output SDO status select
- SDO status output delay times
- Up to 8 MHz (maximum) bit frequency

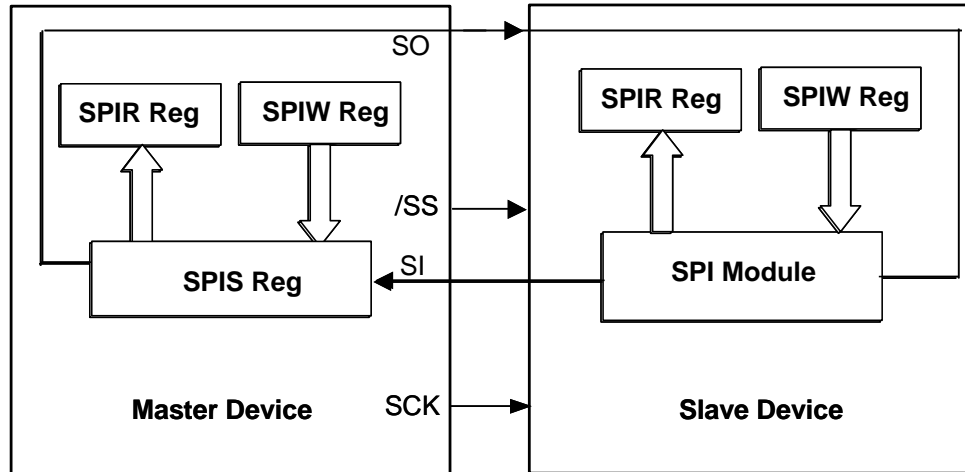

Figure 6-20 SPI Master/Slave Communication

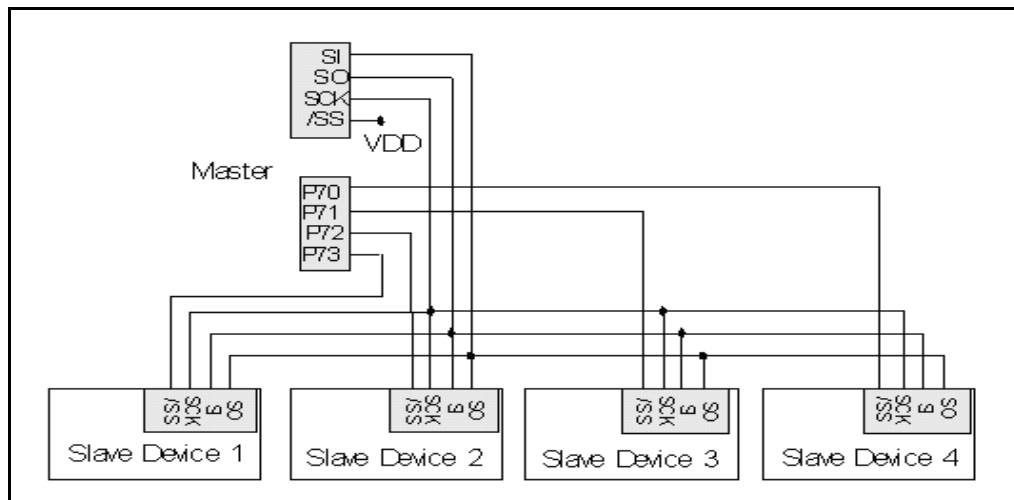

Figure 6-21 SPI Configuration of Single-Master and Multi-Slave

6.12.2 SPI Function Description

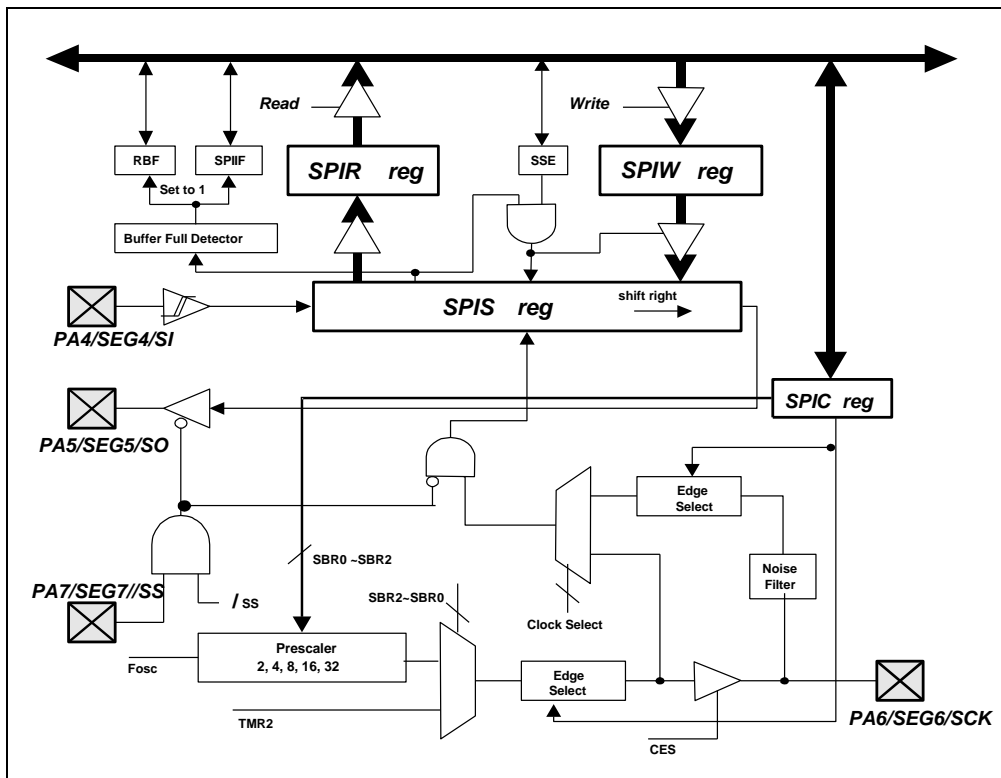

Figure 6-22 SPI Block Diagram

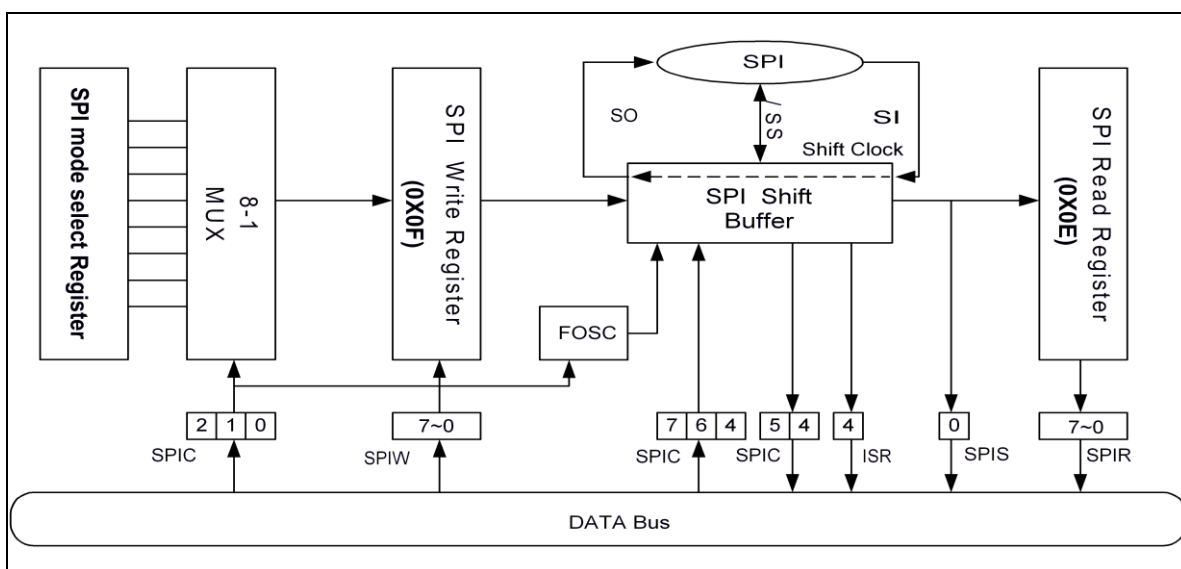

Figure 6-23 Function Block Diagram of SPI Transmission

Below are the functions of each block and explanations on how to carry out the SPI communication with the signals depicted in Figure 6-22 and Figure 6-23.

- PA4/SEG4/SI: Serial Data In
- PA5/SEG5/SO: Serial Data Out
- PA6/SEG6/SCK: Serial Clock
- PA7/SEG7//SS: /Slave Select (Option). This pin (/SS) may be required in slave mode
- RBF: Set by Buffer Full Detector
- Buffer Full Detector: Set to 1 when an 8-bit shifting is completed.
- SSE: Loads the data in SPIS register, and begin to shift
- SPIS reg.: Shifting byte in and out. The MSB is shifted first. Both the SPIR and the SPIW registers are shift at the same time. Once data are written, SPIS starts transmitting / receiving. The data received will be moved to the SPIR register as the shifting of the 8-bit data is completed. The RBF (Read Buffer Full) flag and the SPIIF (SPI Interrupt) flags are then set.
- SPIR reg.: Read buffer. The buffer will be updated as the 8-bit shifting is completed. The data must be read before the next reception is completed. The RBF flag is cleared as the SPIR register reads.
- SPIW reg.: Write buffer. The buffer will deny any attempts to write until the 8-bit shifting is completed.
- The SSE bit will be kept in "1" if the communication is still undergoing. This flag must be cleared as the shifting is completed. Users can determine if the next write attempt is available.
- SBRS2~SBRS0: Programming the clock frequency/rates and sources.
- Clock Select: Selecting either the internal or the external clock as the shifting clock.
- Edge Select: Selecting the appropriate clock edges by programming the CES bit

6.12.3 SPI Signal and Pin Description

The detailed functions of the four pins, SI, SO, SCK, and /SS are as follows:

PA4/SEG4/SI:

- Serial Data In
- Receive sequentially, the Most Significant Bit (MSB) first, Least Significant Bit (LSB) last
- Defined as high-impedance, if not selected

- Program the same clock rate and clock edge to latch on both the master and slave devices.
- The byte received will update the transmitted byte.
- The RBF (located in Register 0x0C) will be set as the SPI operation is completed.
- Timing is shown in Figure 6-23 and 6-24.

PA5/SEG5/SO:

- Serial Data Out
- Transmit sequentially; the Most Significant Bit (MSB) first, Least Significant Bit (LSB) last
- Program the same clock rate and clock edge to latch on both the master and slave devices.
- The received byte will update the transmitted byte.
- The CES (located in Register 0x0D) bit will be reset, as the SPI operation is completed.
- Timing is shown in Figure 6-23 and 6-24.

PA6/SEG6/SCK:

- Serial Clock
- Generated by a master device
- Synchronize the data communication on both the SI and SO pins
- The CES (located in Register 0x0D) is used to select the edge to communicate.
- The SBR0~SBR2 (located in Register 0x0D) is used to determine the baud rate of communication
- The CES, SBR0, SBR1, and SBR2 bits have no effect in slave mode
- Timing is shown in Figure 6-23 and 6-24

PA7/SEG7//SS:

- Slave Select; negative logic
- Generated by a master device to signify the slave(s) to receive data
- Goes low before the first cycle of SCK appears, and remains low until the last 8th cycle is completed.
- Ignores the data on the SI and SO pins while /SS is high, because SO is no longer driven.
- Timing is shown in Figure 6-23 and 6-24.



Note:

1. The Priority of PA4/SEG4/SI Pin

PA4/SEG4/SI Pin Priority		
High	Medium	Low
SI	SEG4	PA4

2. The Priority of PA5/SEG5/SO Pin

PA5/SEG5/SO Pin Priority		
High	Medium	Low
SO	SEG5	PA5

3. The Priority of PA6/SEG6/SCK Pin

PA6/SEG6/SCK Pin Priority		
High	Medium	Low
SCK	SEG6	PA6

4. The Priority of PA7/SEG7//SS Pin

PA7/SEG7//SS Pin Priority		
High	Medium	Low
/SS	SEG7	PA7

6.12.4 Programming the Related Registers

Registers for the SPI Circuit

R_BANK	Address	Name	Bit 7	Bit 6	Bit 5	Bit 4	Bit 3	Bit 2	Bit 1	Bit 0
Bank 2	0X0C	SPIS	DORD	TD1	TD0	-	OD3	OD4	-	RBF
			R/W	R/W	R/W	-	R/W	R/W	-	R
Bank 2	0X0D	SPIC	CES	SPIE	SRO	SSE	SDOC	SBR2	SBR1	SBR0
			R/W	R/W	R/W	R/W	R/W	R/W	R/W	R/W
Bank 2	0X0E	SPIR	SRB7	SRB6	SRB5	SRB4	SRB3	SRB2	SRB1	SRB0
			R/W	R/W	R/W	R/W	R/W	R/W	R/W	R/W
Bank 2	0X0F	SPIW	SWB7	SWB6	SWB5	SWB4	SWB3	SWB2	SWB1	SWB0
			R/W	R/W	R/W	R/W	R/W	R/W	R/W	R/W
Bank 0	0X0E	IMR	T1IE	LVDIE	ADIE	SPIE	URTIE	EXIE9	EXIE8	TCIE
			R/W	R/W	R/W	R/W	R/W	R/W	R/W	R/W
Bank 0	0X0F	ISR	T1IF	LVDIF	ADIF	SPIF	URTIF	EXIF9	EXIF8	TCIF
			R/W	R/W	R/W	R/W	R/W	R/W	R/W	R/W

As the SPI mode is defined, the related registers of this operation are shown.

Related Control Registers of the SPI Mode

Address	Name	Bit 7	Bit 6	Bit 5	Bit 4	Bit 3	Bit 2	Bit 1	Bit 0
Bank 2 0x0D	SPIC	CES	SPIE	SRO	SSE	SDOC	SBR2	SBR1	SBR0
Bank 0 0x0E	IMR	T1IE	LVDIE	ADIE	SPIE	URTIE	EXIE9	EXIE8	TCIE

SPIC: SPI Control Register

Bit 7 (CES): Clock Edge Select Bit

0 : Data shifts out on a rising edge, and shifts in on a falling edge. Data is on hold during a low-level.

1 : Data shifts out on a falling edge, and shifts in on a rising edge. Data is on hold during a high-level.

Bit 6 (SPIE): SPI Enable Bit

0 : Disable SPI mode

1 : Enable SPI mode

Bit 5 (SRO): SPI Read Overflow Bit

0 : No overflow

1 : A new data is received while the previous data is still being held in the SPIRB register. In such situation, the data in the SPI register will be destroyed. To avoid setting this bit, users are required to read the SPIRB register although only transmission is implemented. This can only occur in slave mode.

Bit 4 (SSE): SPI Shift Enable Bit

0 : Resets as soon as the shift is completed, and the next byte is read to shift.

1 : Starts to shift, and remained on "1" while the current byte is still being transmitted.

Bit 3 (SDOC): SDO Output Status Control Bit

0 : After the serial data output, the SDO remain high.

1 : After the serial data output, the SDO remain low.

Bits 2~0 (SBRS2~SBRS0): SPI Baud Rate Select Bits

SBRS2	SBRS1	SBRS0	Mode	SPI Baud Rate
0	0	0	Master	Fosc/2
0	0	1	Master	Fosc/4
0	1	0	Master	Fosc/8
0	1	1	Master	Fosc/16
1	0	0	Master	Fosc/32
1	0	1	Master	Timer 2
1	1	0	Slave	/SS enable
1	1	1	Slave	/SS disable

IMR: Interrupt Mask Register



Bit 4 (SPIIE): Interrupt Enable Bit

0 : Disable SPIIF interrupt

1 : Enable SPIIF interrupt

Related Status/Data Registers of the SPI Mode

Address	Name	Bit 7	Bit 6	Bit 5	Bit 4	Bit 3	Bit 2	Bit 1	Bit 0
0X0C	SPIS	DORD	TD1	TD0	-	OD3	OD4	-	RBF
0x0E	SPIR	SRB7	SRB6	SRB5	SRB4	SRB3	SRB2	SRB1	SRB0
0x0F	SPIW	SWB7	SWB6	SWB5	SWB4	SWB3	SWB2	SWB1	SWB0

SPIS: SPI Status Register

Bit 7 (DORD): Data Shift Control Bit

0 : Shift left (MSB first)

1 : Shift right (LSB first).

Bits 6~5 (TD1~TD0): SDO Status Output Delay Times Options

TD1	TD0	Delay Time
0	0	8 CLK
0	1	16 CLK
1	0	24 CLK
1	1	32 CLK

Bit 4: Reserved

Bit 3 (OD3): Open-Drain Control Bit

0 : Open-drain disable for SDO.

1 : Open-drain enable for SDO

Bit 2 (OD4): Open-Drain Control Bit

0 : Open-drain disable for SCK

1 : Open-drain enable for SCK

Bit 1: Reserved

Bit 0 (RBF): Read Buffer Full Flag

0 : Receiving not completed, and SPIRB has not fully exchanged.

1 : Receiving completed, and SPIRB is fully exchanged.

SPIRB: SPI Read Buffer. Once the serial data is received completely, it will load to SPIRB from SPIS register. The RBF bit in the SPIS register will also be set.

SPIWB: SPI Write Buffer. As a transmitted data is loaded, the SPIS register stands by and start to shift the data when sensing SCK edge with SSE set to "1".

6.12.5 SPI Mode Timing

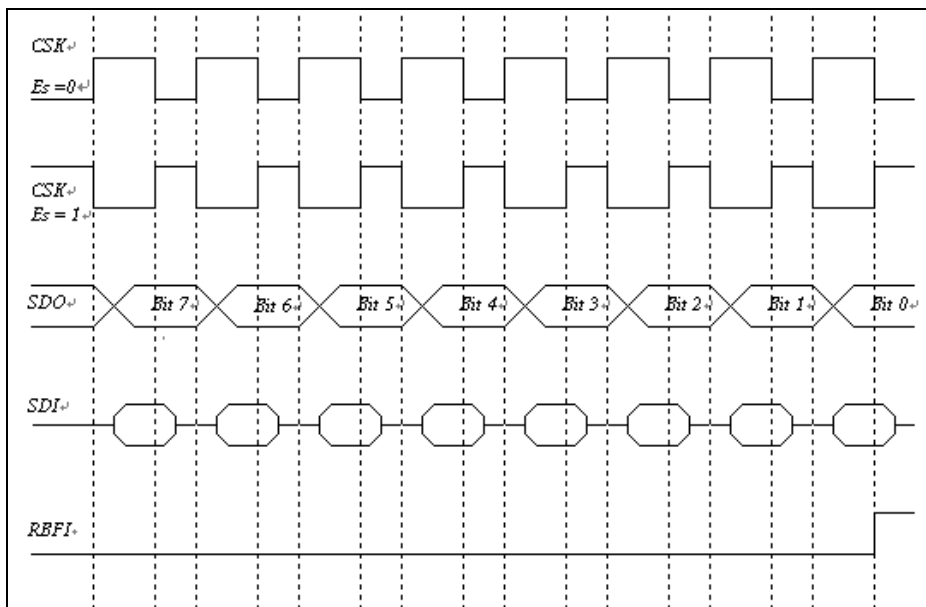

Figure 6-24 SPI Mode with /SS Disabled

The SCK edge is selected by programming bit CES. The waveform shown in Figure 6-24 is applicable regardless of whether the EM78P520N is in master or slave mode with /SS disabled. However, the waveform in Figure 6-25 can only be implemented in slave mode with /SS enabled.

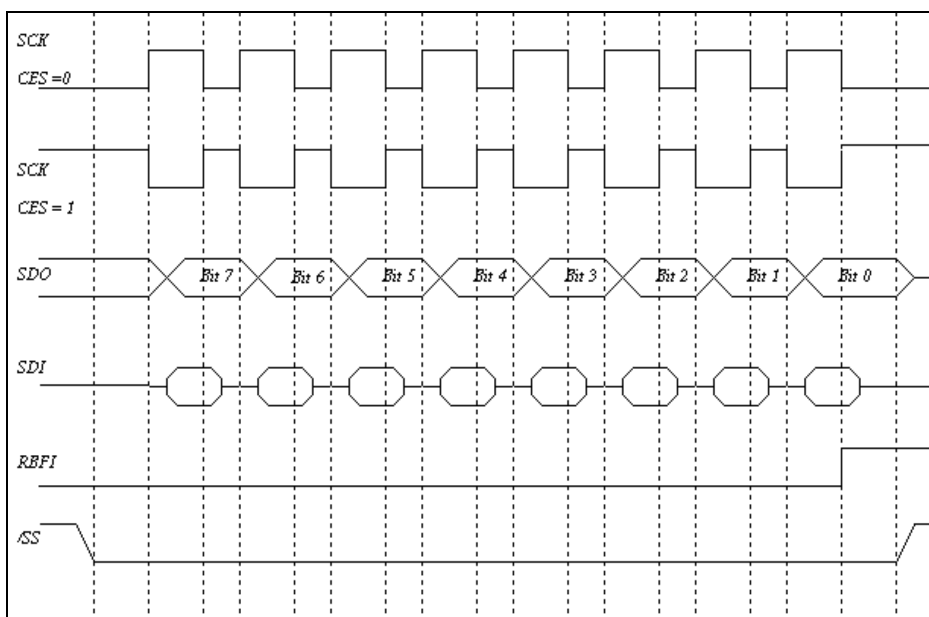

Figure 6-25 SPI Mode with /SS Enabled

6.13 Timer/Counter 1

Registers for Timer/Counter 1 Circuit

R_BANK	Address	Name	Bit 7	Bit 6	Bit 5	Bit 4	Bit 3	Bit 2	Bit 1	Bit 0
Bank 2	0X05	T1CR	TIS1	TIS0	T1MS2	T1MS1	T1MS0	T1P2	T1P1	T1P0
			W	W	W	W	W	W	W	W
Bank 2	0X06	TSR	T1MOD	TRCB	T1CSS1	T1CSS0	T2CSS	T1S	T1OMS	T1OC
			R/W	R/W	R/W	R/W	R/W	R/W	R/W	R/W
Bank 2	0X07	T1PD	PRD1[7]	PRD1[6]	PRD1[5]	PRD1[4]	PRD1[3]	PRD1[2]	PRD1[1]	PRD1[0]
			R/W	R/W	R/W	R/W	R/W	R/W	R/W	R/W
Bank 2	0X08	T1TD	TD1[7]	TD1[6]	TD1[5]	TD1[4]	TD1[3]	TD1[2]	TD1[1]	TD1[0]
			R/W	R/W	R/W	R/W	R/W	R/W	R/W	R/W
Bank 0	0x0E	IMR	T1IE	LVDIE	ADIE	SPIIE	URTIE	EXIE9	EXIE8	TCIE
			R/W	R/W	R/W	R/W	R/W	R/W	R/W	R/W
Bank 0	0x0F	ISR	T1IF	LVDIF	ADIF	SPIIF	URTIF	EXIF9	EXIF8	TCIF
			R/W	R/W	R/W	R/W	R/W	R/W	R/W	R/W

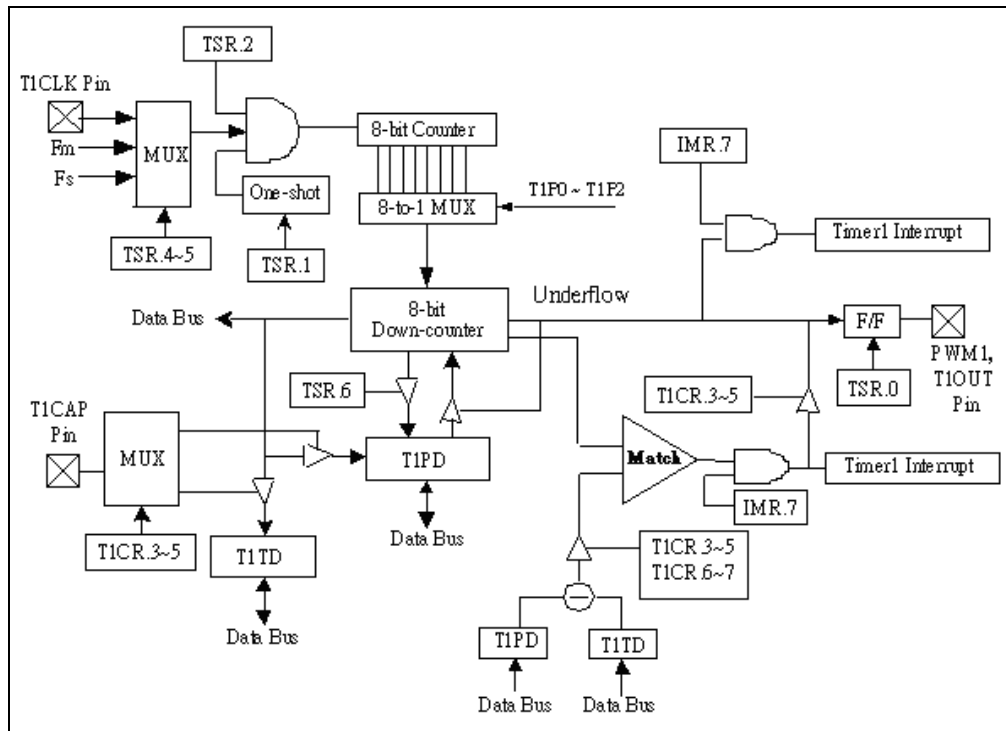

Figure 6-26 Timer/Counter 1 Configuration

6.13.1 Timer Mode

In Timer mode, counting down is performed using the internal clock. The down-counter value auto reloads from T1PD. When the content of the down-counter underflows, an interrupt is generated and the counter is cleared. Counting down resumes after the counter is cleared.

6.13.2 T1OUT Mode

In Timer 1 underflow Output mode, counting down is performed using the internal clock with prescaler or external clock through T1CLK Pin or Sub Frequency with prescaler. The counter value is loaded from T1PD, when the counter underflows. The F/F output is toggled and the counter is auto-reloaded from T1PD, each time an overflow is found. The F/F output is inverted and output to /T1OUT pin. This mode can generate 50% duty pulse output. The program can initialize the F/F and it is initialized to “0” during a reset. A T1OUT interrupt is generated each time the /T1OUT output is toggled.

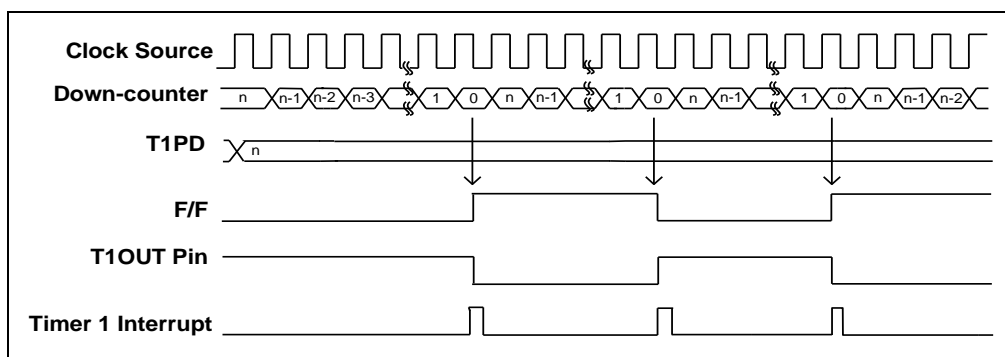

Figure 6-27 T1OUT Mode Timing Diagram

6.13.3 Capture Mode

In Capture mode, the pulse width, period and duty of the T1CAP input pin are measured, which can be used in decoding the remote control signal. The counter is free running by the internal clock. On the rising (falling) edge of T1CAP pin input, the contents of the counter is loaded into T1PD, then the counter is cleared and interrupt is generated. On the falling (rising) edge of T1CAP pin input, the contents of the counter are loaded into T1TD. The counter is still counting, on the next rising edge of the T1CAP pin input, the contents of the counter are loaded into T1PD, the counter is cleared and interrupt is generated again. If an overflow occurs before the edge is detected, 00H is loaded into T1PD and an underflow interrupt is generated. During interrupt processing, it can be determined whether or not there is an overflow by checking whether the T1PD value is 00H. After an interrupt (capture to T1PD or overflow detection) is generated, capture and underflow detection are halted until T1PD is read out.

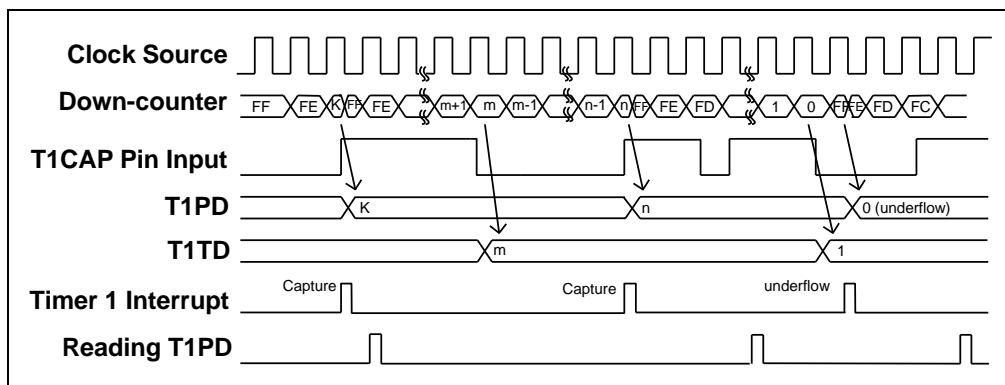

Figure 6-28 Capture Mode Timing Diagram

6.13.4 PWM Mode

In Pulse Width Modulation (PWM) Output mode, counting down is performed using the internal clock with prescaler or external clock through T1CLK Pin or Sub Frequency with prescaler. The Duty of PWM1 is controlled by T1TD, and the period of PWM1 is controlled by T1PD. The pulse at the PWM1 pin is held to a high level as long as the counter value of T1TD is greater than or equal to zero, while the pulse is held to a low level until the counter value of T1PD underflows. The F/F is toggled when underflow occurs. While the counter is still counting, the F/F is toggled again when the counter underflows, then the counter is auto reloaded from T1PD. The F/F output is inverted and output to the /PWM pin. A Timer 1 interrupt is generated each time an underflow occurs. T1PD is configured as a 2-stage shift register and during output, will not switch until one output cycle is completed even if T1PD is overwritten. Therefore, the output can be changed continuously. T1PD is also shifted the first time by setting T1S to “1” after data is loaded to T1PD.

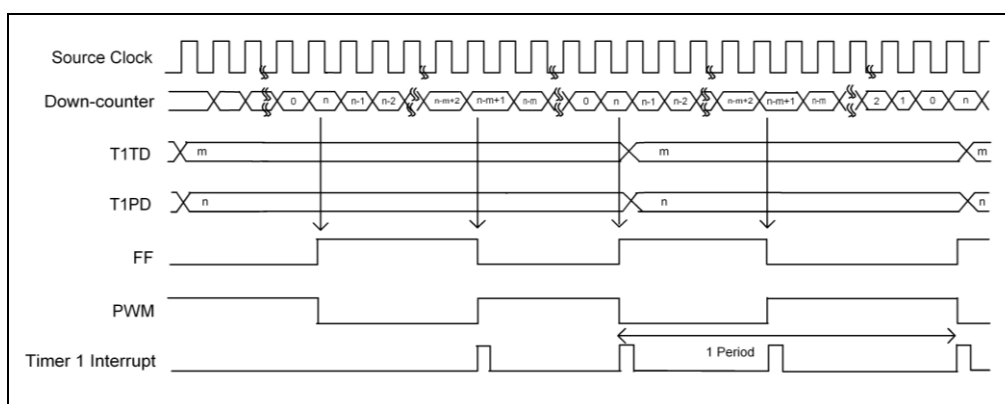

Figure 6-29 PWM Mode Timing Diagram

6.13.5 16-Bit Mode

In 16-bit timer mode, all function in Timer 1 resolution become 16 bits.

6.14 Timer 2

Registers for Timer 2 Circuit

R_BANK	Address	Name	Bit 7	Bit 6	Bit 5	Bit 4	Bit 3	Bit 2	Bit 1	Bit 0
Bank 2	0X06	TSR	T1MOD	TRCB	T1CSS1	T1CSS0	T2CSS	T1S	T1OMS	T1OC
			R/W	R/W	R/W	R/W	R/W	R/W	R/W	R/W
Bank 2	0X09	T2CR	T2IF	T2IE	T2S	T2MS1	T2MS0	T2P2	T2P1	T2P0
			R/W	R/W	R/W	R/W	R/W	R/W	R/W	R/W
Bank 2	0X0A	T2PD	PRD2[7]	PRD2[6]	PRD2[5]	PRD2[4]	PRD2[3]	PRD2[2]	PRD2[1]	PRD2[0]
			R/W	R/W	R/W	R/W	R/W	R/W	R/W	R/W
Bank 2	0X0B	T2TD	TD2[7]	TD2[6]	TD2[5]	TD2[4]	TD2[3]	TD2[2]	TD2[1]	TD2[0]
			R/W	R/W	R/W	R/W	R/W	R/W	R/W	R/W

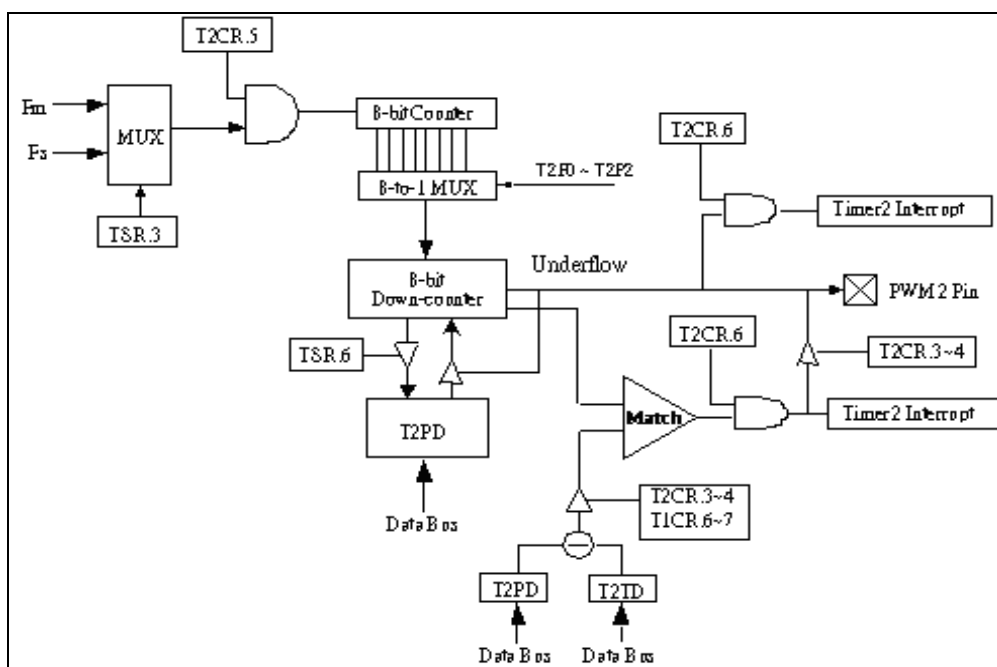

Figure 6-30 Timer 2 Configuration

6.14.1 Timer Mode

In Timer mode, counting down is performed using the internal clock with prescaler. When the counter value from T2PD underflows, interrupt is then generated and the counter is cleared. Counting down resumes after the counter is cleared. The counter value will automatically reload from T2PD.

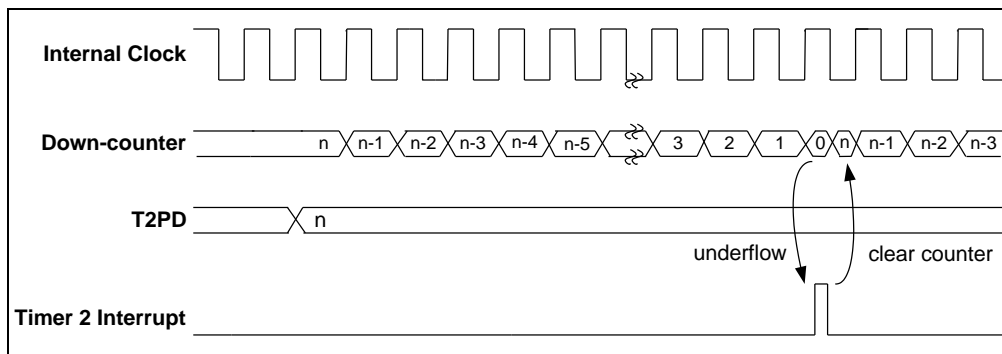

Figure 6-31 Timer Mode Timing Diagram

6.14.2 PWM Mode

In Pulse Width Modulation (PWM) Output mode, counting down is performed using the internal clock with prescaler or F_{sub} with frequency. The PWM2 duty cycle is controlled by T2TD, and the PWM2 period is controlled by T2PD. The pulse at the PWM2 pin is held to high level as long as the T2TD counter value is greater than or equal to zero while the pulse is held to low level until the T2PD counter value underflows.

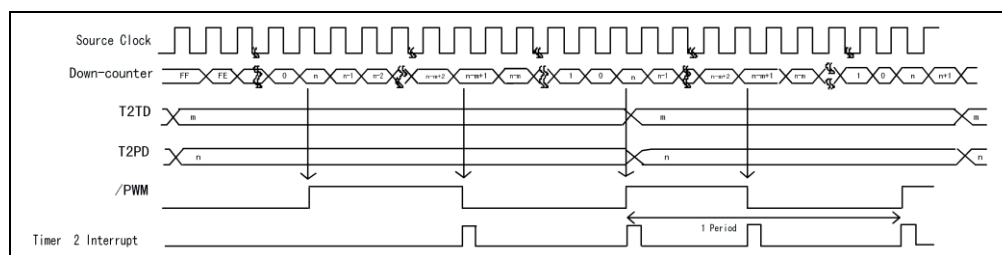

Figure 6-32 PWM Mode Timing Diagram

6.15 Code Options

The EM78P520N has one Code Option word that is not part of the normal program memory. The option bits cannot be accessed during normal program execution.

Code Option Register and Customer ID Register arrangement distribution:

Word 0	Word 1	Word 2
Bit 12~Bit 0	Bit 12~Bit 0	Bit 12~Bit 0

1. Code Option Register (Word 0)

Word 0													
Bit	Bit 12	Bit 11	Bit 10	Bit 9	Bit 8	Bit 7	Bit 6	Bit 5	Bit 4	Bit 3	Bit 2	Bit 1	Bit 0
Mnemonic	TYPE1	TYPE0	LVREN	LVR1	LVR0	ENWDTB	FSMD	FMMD1	FMMD0	HLP	Protect		
1	High	High	Enable	High	High	Disable	High	High	High	High	Disable		
0	Low	Low	Disable	Low	Low	Enable	Low	Low	Low	Low	Enable		

Bits 12~11 (TYPE1~TYPE0): Type Selection for 48 pins or 44 pins.

TYPE1	TYPE0	Type Selection
0	0	Reserved
0	1	Reserved
1	0	EM78P520N (44-pin LQFP/QFP)
1	1	EM78P520N (48-pin LQFP) (default)

Bit 10 (LVREN): Low Voltage Reset Enable Bit

0 : Disable

1 : Enable

Bits 9~8 (LVR1~LVR0): Low Voltage Reset Voltage Select Bits

LVR1	LVR0	Reset Voltage
0	0	2.6V
0	1	3.3V
1	0	3.9V

Bit 7 (ENWDTB): Watchdog Timer Enable Bit

0 : Enable

1 : Disable

Bits 6~4 (FSMD, FMMD1~FMMD0): Oscillator Modes Selection Bits

FSMD	FMMD1	FMMD0	Main Oscillator	Sub Oscillator
0	0	0	RC type (ERIC)	RC type (ERIC)
0	0	1	Crystal type	RC type (ERIC)
0	1	0	PLL type	RC type (ERIC)
0	1	1	PLL type	RC type (ERIC)
1	0	0	RC type (ERIC)	Crystal type
1	0	1	Crystal type	Crystal type
1	1	0	PLL type	Crystal type
1	1	1	Crystal	None



Bit 3 (HLP): Power Consumption Select Bit

0 : Low power consumption, apply to working frequency at 4 MHz or below 4 MHz.

1 : High power consumption, apply to working frequency above 4 MHz.

Bits 2~0 (Protect): Protect Bit

Protect are protect bits, protect type are as follows:

0 : Enable

1 : Disable

2. Code Option Register (Word 1)

Word 1													
Bit	Bit 12	Bit 11	Bit 10	Bit 9	Bit 8	Bit 7	Bit 6	Bit 5	Bit 4	Bit 3	Bit 2	Bit 1	Bit 0
Mnemonic	-	-	-	-	-	-	-	HLFS	-	-	FCB0	FCB1	RESETENB
1	-	-	-	-	-	-	-	Main Oscillator	-	-	High	High	P81
0	-	-	-	-	-	-	-	Sub Oscillator	-	-	Low	Low	/RESET

Bits 12~7: Not used, but must be cleared to “1” all the time to avoid possible error.

Bit 6: Not used, but must be cleared to “0” all the time to avoid possible error.

Bit 5 (HLFS): Main or Sub Oscillator Select Bit

0 : CPU is selected as sub-oscillator when a reset occurs

1 : CPU is selected as main-oscillator when a reset occurs

Bits 4~3: Not used, but must be cleared to “1” all the time to avoid possible error.

Bits 2~1 (FCB0~FCB1): Frequency for Crystal (main oscillator) Select Bit

FCB1	FCB0	Operation Frequency
0	0	100k~1M
0	1	1M~6M
1	0	6M~12M
1	1	12M~20M

Bit 0 (RESETENB): Reset Pin Enable Bit

0 : Enable, P81//RESET → /RESET pin

1 : Disable, P81//RESET → P81

3. Customer ID Register (Word 2)

Word 2													
Bit 12	Bit 11	Bit 10	Bit 9	Bit 8	Bit 7	Bit 6	Bit 5	Bit 4	Bit 3	Bit 2	Bit 1	Bit 0	
Customer ID													

6.16 Instruction Set

Each instruction in the Instruction Set is a 13-bit word divided into an OP code and one or more operand. Normally, all instructions are executed within one single instruction cycle (one instruction consists of 2 oscillator periods), unless the program counter is changed by instruction "MOV R2,A", "ADD R2,A", or by instructions of arithmetic or logic operation on R2 (e.g. "SUB R2,A", "BS(C) R2,6", "CLR R2",...). In this case, the execution takes two instruction cycles.

The following are executed within two instruction cycles; "LJMP", "LCALL", or conditional skip ("JBS", "JBC", "JZ", "JZA", "DJZ", "DJZA") instructions which were tested to be true. Instructions written to the program counter are also executed within two instruction cycles.

In addition, the instruction set has the following features:

- (1) Every bit of any register can be set, cleared, or tested directly.
- (2) The I/O register can be regarded as general register. That is, the same instruction can operate on the I/O register.

Convention:

r = Register designator that specifies which one of the registers (including operation and general purpose registers) is to be utilized by the instruction.

Bits 6 and 7 in R4 determine the selected register bank.

b = Bit field designator that selects the value for the bit located in the register R and which affects the operation.

k = 8 or 10-bit constant or literal value

Mnemonic	Operation	Status Affected
NOP	No Operation	None
DAA	Decimal Adjust A	C
SLEP	0 → WDT, Stop oscillator	T, P
WDTC	0 → WDT	T, P
ENI	Enable Interrupt	None
DISI	Disable Interrupt	None
RET	[Top of Stack] → PC	None
RETI	[Top of Stack] → PC, Enable Interrupt	None
MOV R,A	A → R	None
CLRA	0 → A	Z
CLR R	0 → R	Z

Mnemonic	Operation	Status Affected
SUB A,R	$R-A \rightarrow A$	Z, C, DC
SUB R,A	$R-A \rightarrow R$	Z, C, DC
DECA R	$R-1 \rightarrow A$	Z
DEC R	$R-1 \rightarrow R$	Z
OR A,R	$A \vee R \rightarrow A$	Z
OR R,A	$A \vee R \rightarrow R$	Z
AND A,R	$A \& R \rightarrow A$	Z
AND R,A	$A \& R \rightarrow R$	Z
XOR A,R	$A \oplus R \rightarrow A$	Z
XOR R,A	$A \oplus R \rightarrow R$	Z
ADD A,R	$A + R \rightarrow A$	Z, C, DC
ADD R,A	$A + R \rightarrow R$	Z, C, DC
MOV A,R	$R \rightarrow A$	Z
MOV R,R	$R \rightarrow R$	Z
COMA R	$/R \rightarrow A$	Z
COM R	$/R \rightarrow R$	Z
INCA R	$R+1 \rightarrow A$	Z
INC R	$R+1 \rightarrow R$	Z
DJZA R	$R-1 \rightarrow A$, skip if zero	None
DJZ R	$R-1 \rightarrow R$, skip if zero	None
RRCA R	$R(n) \rightarrow A(n-1)$, $R(0) \rightarrow C$, $C \rightarrow A(7)$	C
RRC R	$R(n) \rightarrow R(n-1)$, $R(0) \rightarrow C$, $C \rightarrow R(7)$	C
RLCA R	$R(n) \rightarrow A(n+1)$, $R(7) \rightarrow C$, $C \rightarrow A(0)$	C
RLC R	$R(n) \rightarrow R(n+1)$, $R(7) \rightarrow C$, $C \rightarrow R(0)$	C
SWAPA R	$R(0-3) \rightarrow A(4-7)$, $R(4-7) \rightarrow A(0-3)$	None
SWAP R	$R(0-3) \leftrightarrow R(4-7)$	None
JZA R	$R+1 \rightarrow A$, skip if zero	None

Mnemonic	Operation	Status Affected
JZ R	$R+1 \rightarrow R$, skip if zero	None
BC R,b	$0 \rightarrow R(b)$	None
BS R,b	$1 \rightarrow R(b)$	None ¹
JBC R,b	if $R(b)=0$, skip	None
JBS R,b	if $R(b)=1$, skip	None
CALL k	$PC+1 \rightarrow [\text{Stack}]$, (Page, k) $\rightarrow PC$	None
LCALL k	$PC+1 \rightarrow [\text{Stack}]$, K $\rightarrow PC$	None
JMP k	(Page, k) $\rightarrow PC$	None
LJMP k	K $\rightarrow PC$	None
MOV A,k	k $\rightarrow A$	None
OR A,k	$A \vee k \rightarrow A$	Z
AND A,k	$A \& k \rightarrow A$	Z
XOR A,k	$A \oplus k \rightarrow A$	Z
RETL k	k $\rightarrow A$, [Top of Stack] $\rightarrow PC$	None
SUB A,k	$k-A \rightarrow A$	Z, C, DC
BANK k	k $\rightarrow R5(2:0)$	None
ADD A,k	$k+A \rightarrow A$	Z, C, DC

Note: ¹ This instruction cannot operate under interrupt status register.

7 Absolute Maximum Ratings

Items	Symbol	Condition	Rating		Unit
			Min.	Max.	
Supply voltage	V _{DD}	–	2.3	5.5	V
Input voltage	V _I	Port 7 ~ Port 9, Port A ~ Port C	GND-0.3	VDD+0.3	V
Output voltage	V _O	Port 7 ~ Port 9, Port A ~ Port C	GND-0.3	VDD+0.3	V
Operation temperature	T _{OPR}	–	-40	85	°C
Storage temperature	T _{STG}	–	-65	150	°C
Power dissipation	P _D	–	–	500	mW
Operating Frequency (2clk)	–	–	32.768K	16M	Hz

8 DC Electrical Characteristics

8.1 DC Electrical Characteristics

- Ta= 25°C, VDD= 5.0V±5%, VSS= 0V

Symbol	Parameter	Condition	Min.	Typ.	Max.	Unit
Fc	Crystal: VDD to 5V	Two cycles with two clocks	0.1	–	16	MHz
ERIC	ERIC: VDD to 5V	R: 51KΩ	F-20%	2.2221	F+20%	MHz
IIL	Input Leakage Current for input pins	VIN = VDD, VSS	-1	0	1	μA
VIH1	Input High Voltage (Schmitt Trigger)	Ports 7, 8, 9, A, B, C	0.75VDD	–	VDD+0.3V	V
VIL1	Input Low Voltage (Schmitt Trigger)	Ports 7, 8, 9, A, B, C	-0.3V	–	0.25VDD	V
VIHT1	Input High Threshold Voltage (Schmitt Trigger)	/RESET, INT	0.75VDD	–	VDD+0.3V	V
VILT1	Input Low Threshold Voltage (Schmitt Trigger)	/RESET, INT	-0.3V	–	0.25VDD	V
VIHX1	Clock Input High Voltage	OSCI in crystal mode	0.75VDD	–	VDD+0.3V	V
VILX1	Clock Input Low Voltage	OSCI in crystal mode	-0.3V	–	0.25VDD	V
IOH1	High Drive Current 1 (Port 9) LED enabled	VOH = VSS+2.1V	8	10	15	mA
IOH2	High Drive Current 2 (Ports 7, 8, 9, A, B, C)	VOH = VDD-0.1VDD	7	9	12	mA
IOL1	Low Sink Current 1 (Port 9) LED enabled	VOL = VDD-2.1	8	10	15	mA
IOL2	Low Sink Current 2 (Ports 7, 8, 9, A, B, C)	VOL = VSS+0.1VDD	16	18	21	mA



Symbol	Parameter	Condition		Min.	Typ.	Max.	Unit
IPH1	Pull-high current	Pull-high active, input pin at VSS		-70	-75	-80	μA
LVR1	Low Voltage Reset Level 1 (2.6V)	Ta = 25°C		2.31	2.6	2.89	V
		Ta = -40°C ~ 85°C		2.04	2.6	3.15	V
LVR2	Low Voltage Reset Level 2 (3.3V)	Ta = 25°C		2.9	3.3	3.72	V
		Ta = -40°C ~ 85°C		2.53	3.3	4.05	V
LVR3	Low Voltage Reset Level 3 (3.9V)	Ta = 25°C		3.46	3.9	4.33	V
		Ta = -40°C ~ 85°C		3.06	3.9	4.71	V
ISB1	Stop mode Power down current	All input and I/O pins at VDD	WDT disabled	-	1.1	-	μA
ISB2	Stop mode Power down current		Output pin floating	WDT enabled	-	6.6	-
ICC1	Idle mode current	/RESET= 'High', CPU OFF, Sub-oscillator clock (32.768kHz) ON, Output pin floating, WDT disabled		-	4.7	-	μA
ICC2	Idle mode current	/RESET= 'High', CPU OFF, Sub-oscillator clock (32.768kHz) ON, Output pin floating, WDT enabled,		-	10.3	-	μA
ICC3	Idle mode current	/RESET= 'High', CPU OFF, Sub-oscillator clock (32.768kHz) ON, Output pin floating, WDT disabled, LCD enabled		-	23.7	-	μA
ICC4	Green mode current	/RESET= 'High', CPU ON, used Sub-oscillator clock (32.768kHz), Output pin floating, WDT enabled,		-	21.4	-	μA
ICC5	Normal mode	/RESET= 'High', Fosc=4 MHz (Crystal type, CLKS="0"), Output pin floating, WDT enabled		-	1.48	-	mA
ICC6	Normal mode	/RESET= 'High', Fosc=16 MHz (Crystal type, CLKS="0"), Output pin floating, WDT enabled		-	3.45	-	mA
RLCD	LCD Voltage Dividing Resistor	Ta = 25°C		-	80	-	KΩ
ILCD1	All LCD lighting	VLCD=5V, exclude CPU core operation current (not panel)		-	23.3	-	μA
ILCD2	All LCD lighting	VLCD=3V, exclude CPU core operation current (not panel)		-	12.9	-	μA

Note: 1. These parameters are hypothetical (not tested) and are provided for design reference use only.
2. Data under minimum, typical, and maximum (Min., Typ., and Max.) columns are based on hypothetical results at 25°C. These data are for design reference only.

8.2 A/D Converter Characteristics

■ VDD=2.5V to 5.5V, VSS=0V, Ta=-40 to 85°C

Symbol	Parameter	Condition	Min.	Typ.	Max.	Unit	
VREF	Analog reference voltage	VREF – VSS ≥ 2.5V	2.5	–	VDD	V	
VSS			VSS	–	VSS	V	
VAI	Analog input voltage	–	VSS	–	VREF	V	
IAI1	Analog supply current	VDD=VREF=5.0V, VSS = 0.0V (V reference from VDD)	Ivdd	750	850	1000	μA
			Ivref	-10	0	+10	μA
IAI2	Analog supply current	VDD=VREF=5.0V, VSS = 0.0V (V reference from VREF)	Ivdd	500	600	820	μA
			Ivref	200	250	300	μA
RN1	Resolution	ADREF=0, Internal VDD VDD=5.0V, VSS = 0.0V	–	9	10	Bits	
RN2	Resolution	ADREF=1, External VREF VDD=VREF=5.0V, VSS = 0.0V	–	11	12	Bits	
LN1	Linearity error	VDD= 2.5 to 5.5V Ta=25°C	0	±4	±8	LSB	
LN2	Linearity error	VDD= 2.5 to 5.5V Ta=25°C	0	±2	±4	LSB	
DNL	Differential non-linear error	VDD= 2.5 to 5.5V Ta=25°C	0	±0.5	±0.9	LSB	
FSE1	Full scale error	VDD=5.0V, VASS = 0.0V	±0	±4	±8	LSB	
FSE2	Full scale error	VDD=VREF=5.0V, VSS = 0.0V	±0	±2	±4	LSB	
OE	Offset error	VDD=VREF=5.0V, VSS = 0.0V	±0	±2	±4	LSB	
ZAI	Recommended impedance of analog voltage source	–	0	8	10	KΩ	
ADIV	A/D input voltage range	VDD =VREF=5.0V, VSS = 0.0V	0	–	VREF	V	
ADOV	A/D output voltage swing	VDD =VREF=5.0V, VSS = 0.0V, RL=10KΩ	0	0.2	0.3	V	
			4.7	4.8	5		
TAD	A/D clock period	VDD=VREF=5.0V, VSS = 0.0V	4	–	–	μs	
TCN	A/D conversion time	VDD=VREF=5.0V, VSS = 0.0V	15	–	15	TAD	
PSR	Power Supply Rejection	VDD=5.0V±0.5V	±0	–	±2	LSB	

- Note:** 1. These parameters are hypothetical (not tested) and are provided for design reference only.
 2. There is no current consumption when ADC is off other than minor leakage current.
 3. AD conversion result will not decrease when the input voltage is increased, and no missing code will result.

8.3 Phase Lock Loop Characteristics

8.3.1 PLL DC Electrical Characteristics

Symbol	Parameter	Condition	Min.	Typ.	Max.	Unit
VD	Digital Supply Voltage	–	4.5	–	5.5	V

8.3.2 AC Electrical Characteristics

Parameter	Condition			Min	Typ	Max	Unit
Input Clock	–			–	32.768	–	kHz
Output Clock	CLK2	CLK1	CLK0	–	–	–	–
	1	1	X	–	15.99	–	MHz
Current Consumption	Normal			–	–	600	μA
	Power Down Mode			–	–	1	μA
Lock Up Time	–			–	–	200	μs
Settling Time	–			–	3	5	ms

Note: 1. These parameters are hypothetical (not tested) and are provided for design reference only.

2. These parameters are subject to change without further notice.

8.4 Device Characteristics

The graphs provided in the following pages were derived based on a limited number of samples and are shown here for reference only. The device characteristics illustrated herein are not guaranteed for its accuracy. In some graphs, the data may be out of the specified warranted operating range.

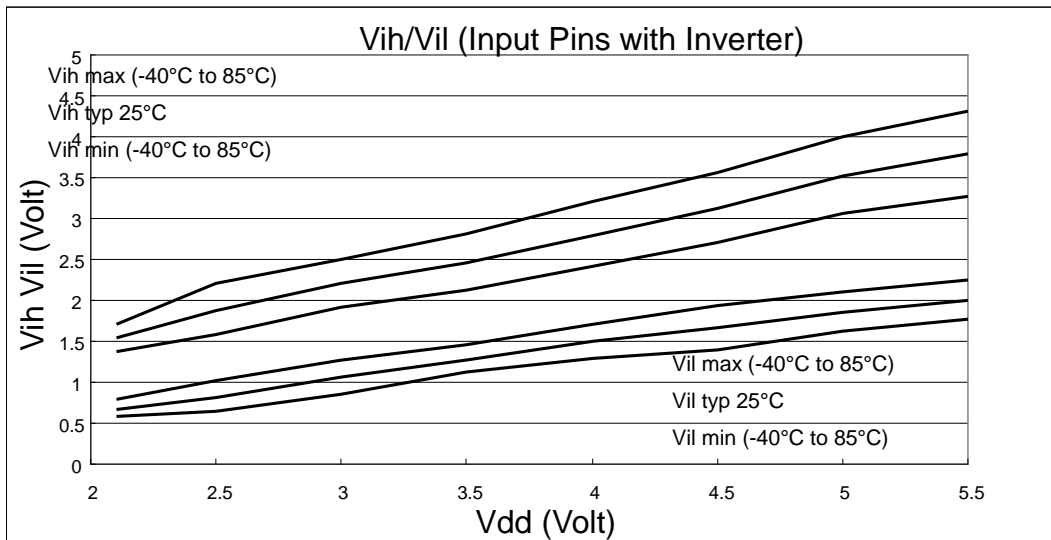

Figure 8-1 Vih, Vil vs. VDD

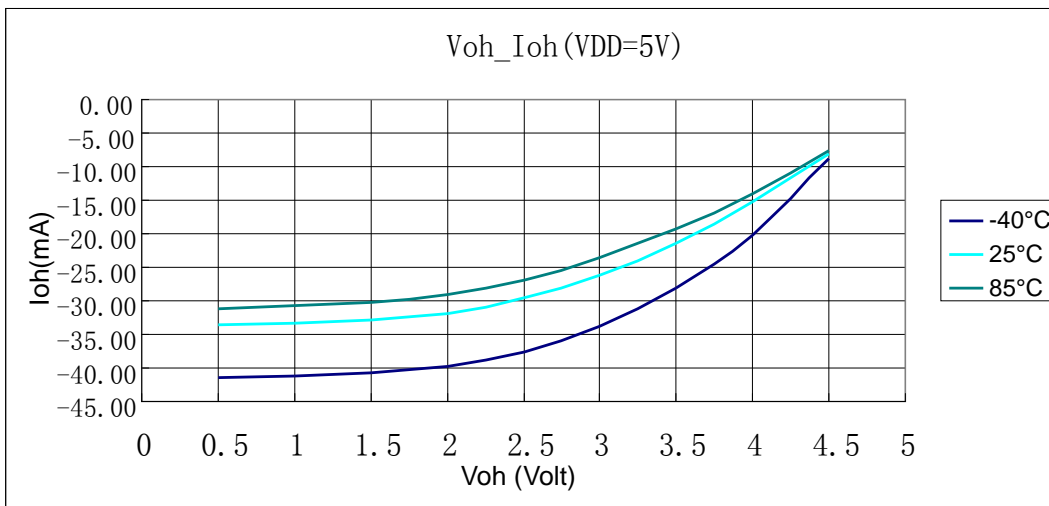

Figure 8-2 Voh vs. Ioh, VDD=5V

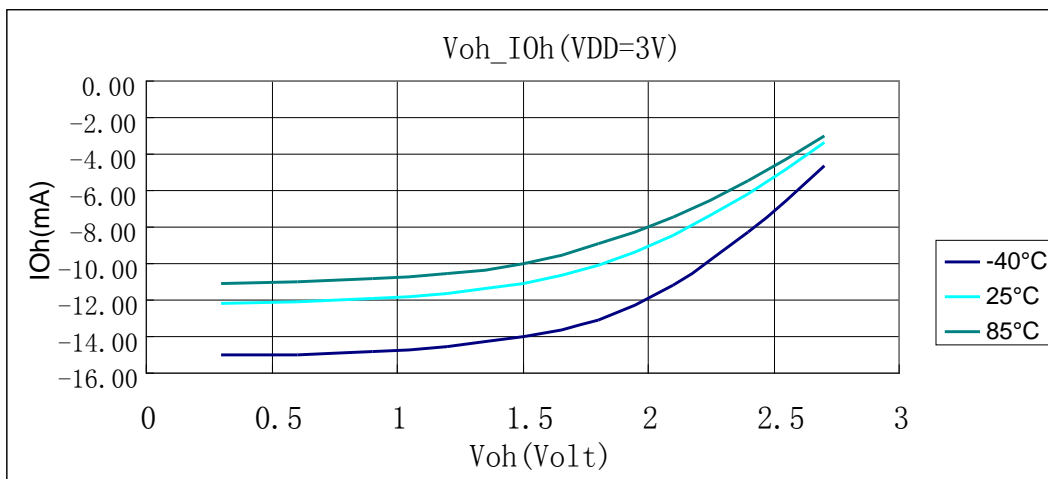

Figure 8-3 Voh vs. Ioh, VDD=3V

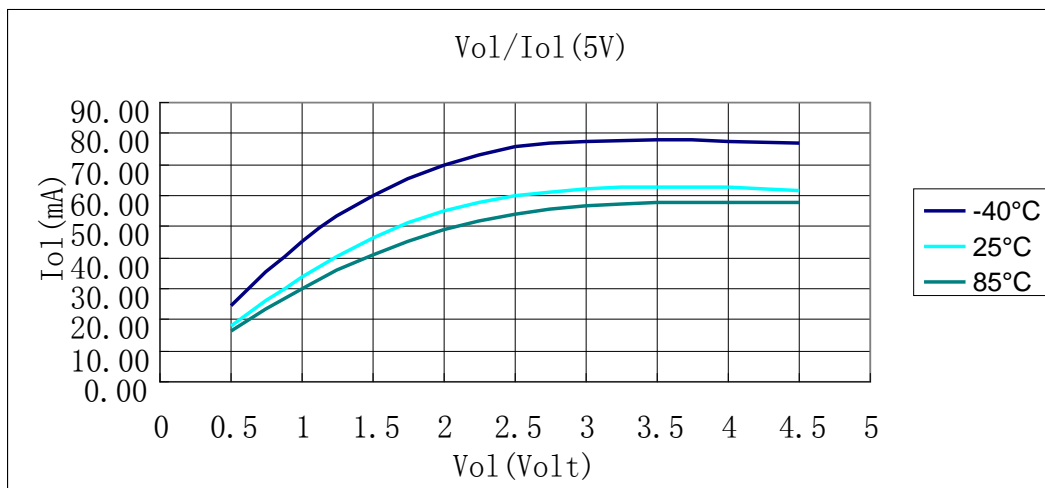

Figure 8-4 Vol vs. Iol, VDD=5V

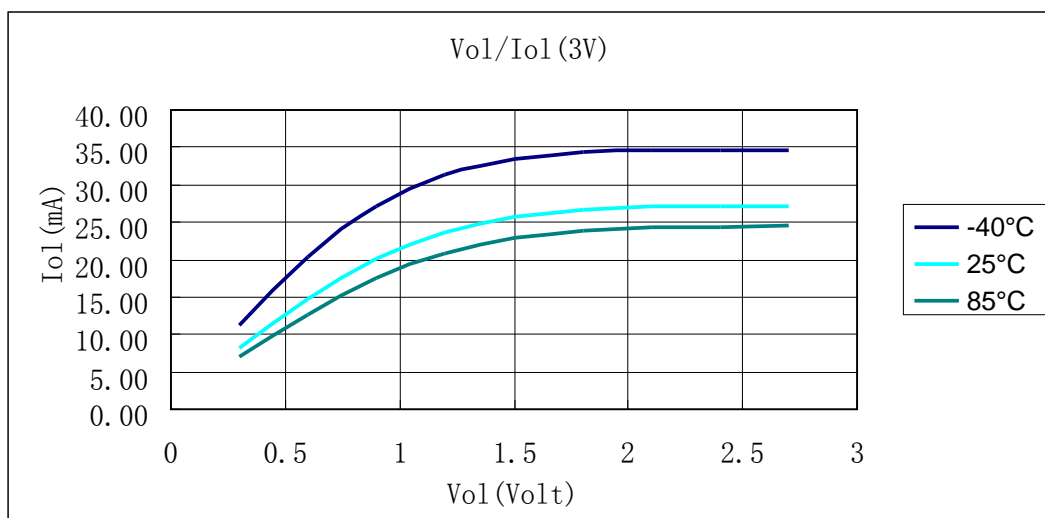

Figure 8-5 Vol vs. Iol, VDD=3V

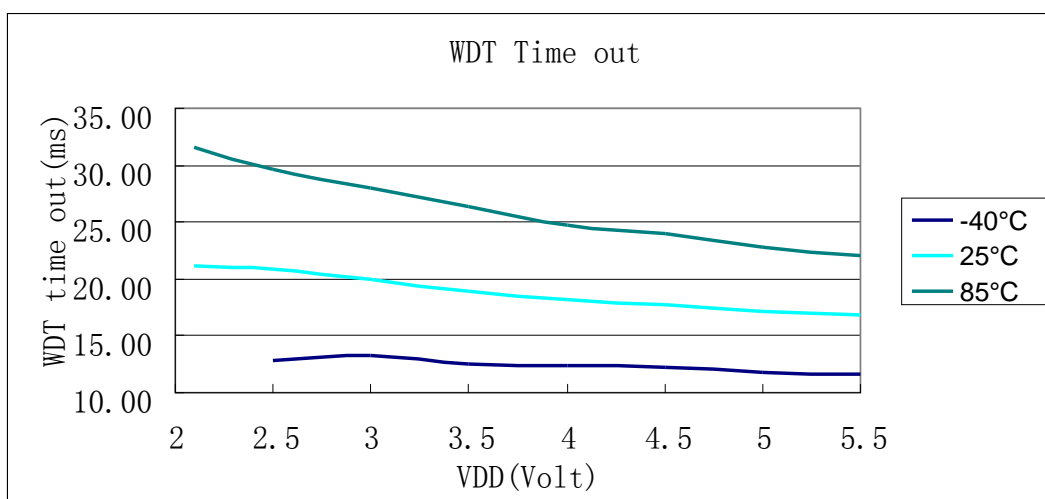

Figure 8-6 WDT Time out Period vs. VDD, with Prescaler set to 1:1

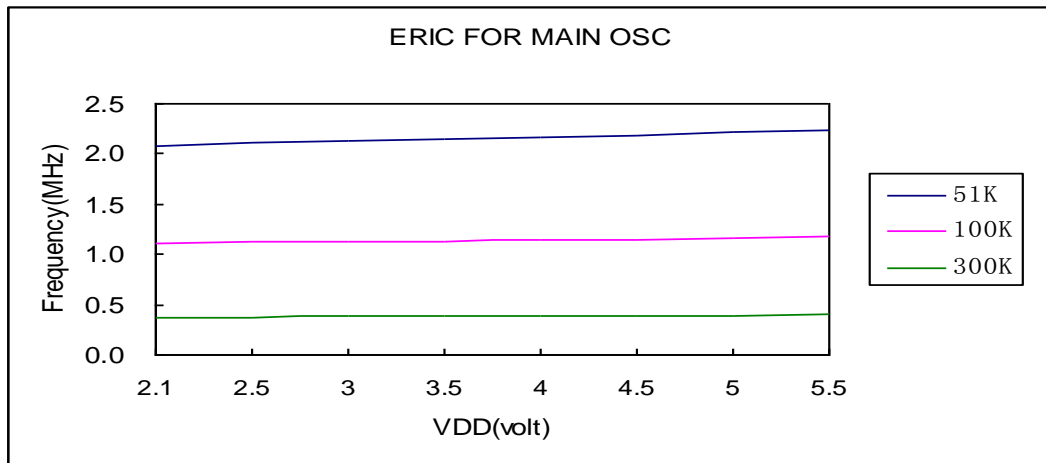

Figure 8-7 ERIC fosc vs. VDD

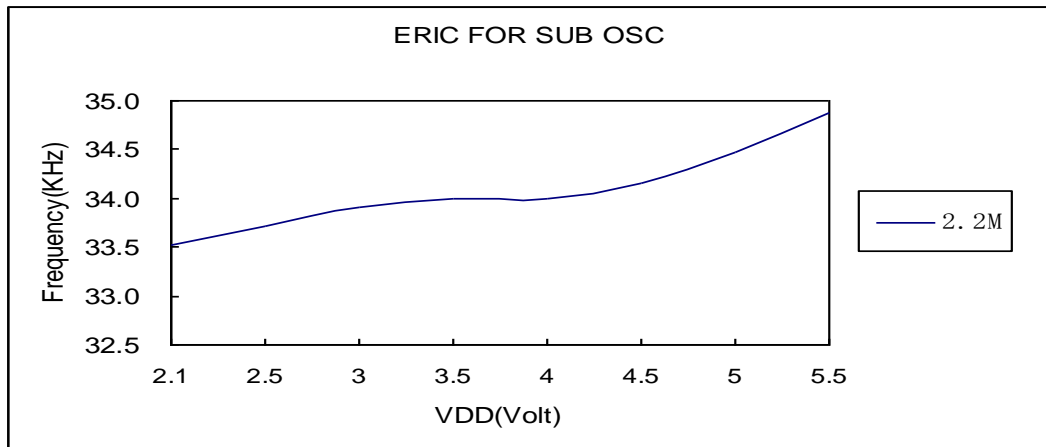

Figure 8-8 ERIC fs vs. VDD

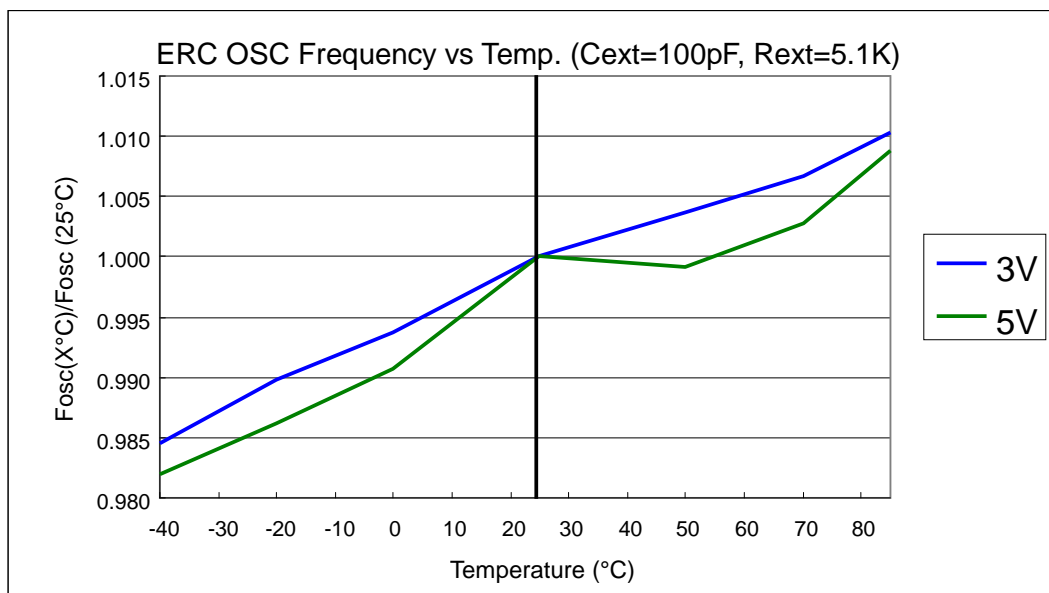

Figure 8-9 ERIC fosc vs. Temperature

There are two conditions with the Standby Current ISB1 and ISB2. These conditions are as follows:

ISB1: WDT disable (Sleep mode)

ISB2: WDT enable (Sleep mode)

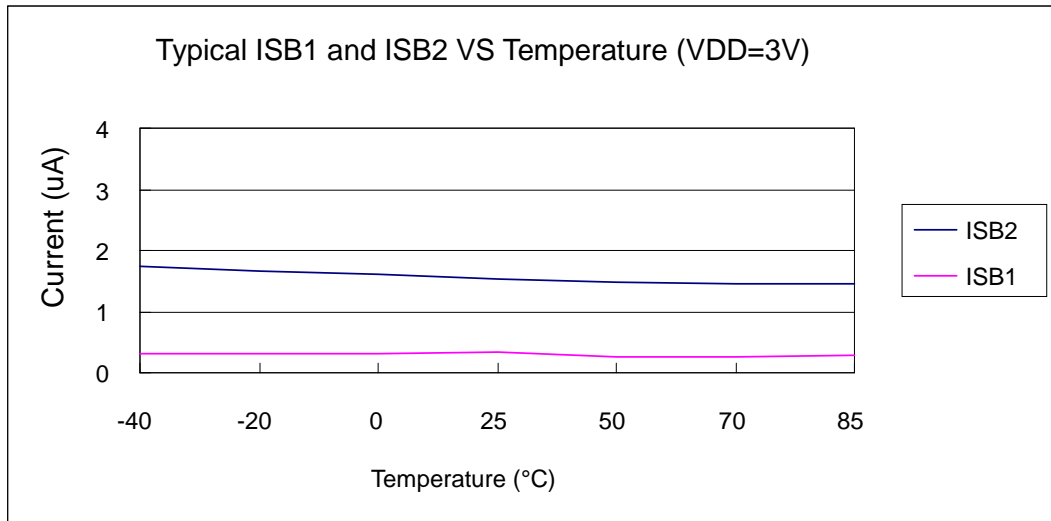

Figure 8-11 Typical Standby Current (VDD=3V) vs. Temperature

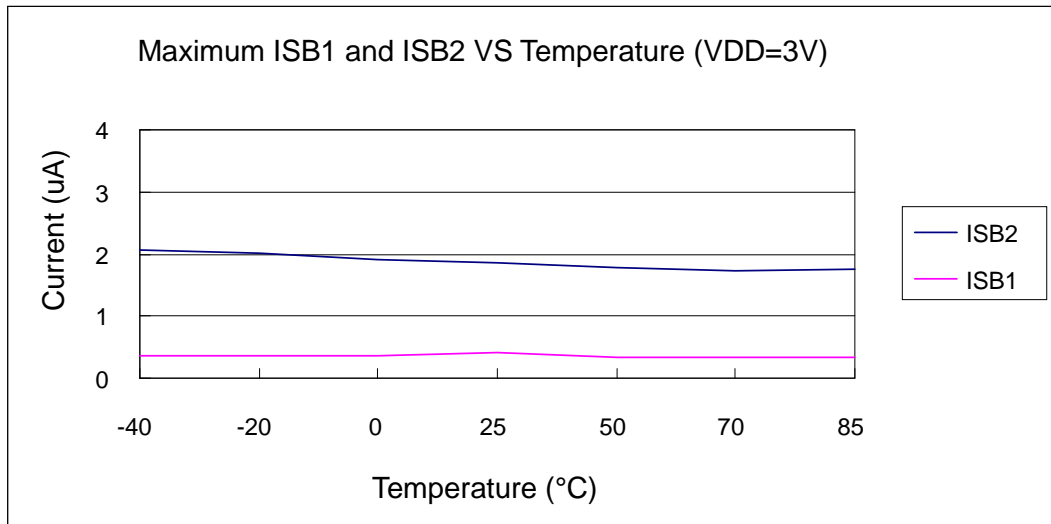

Figure 8-12 Maximum Standby Current (VDD=3V) vs. Temperature

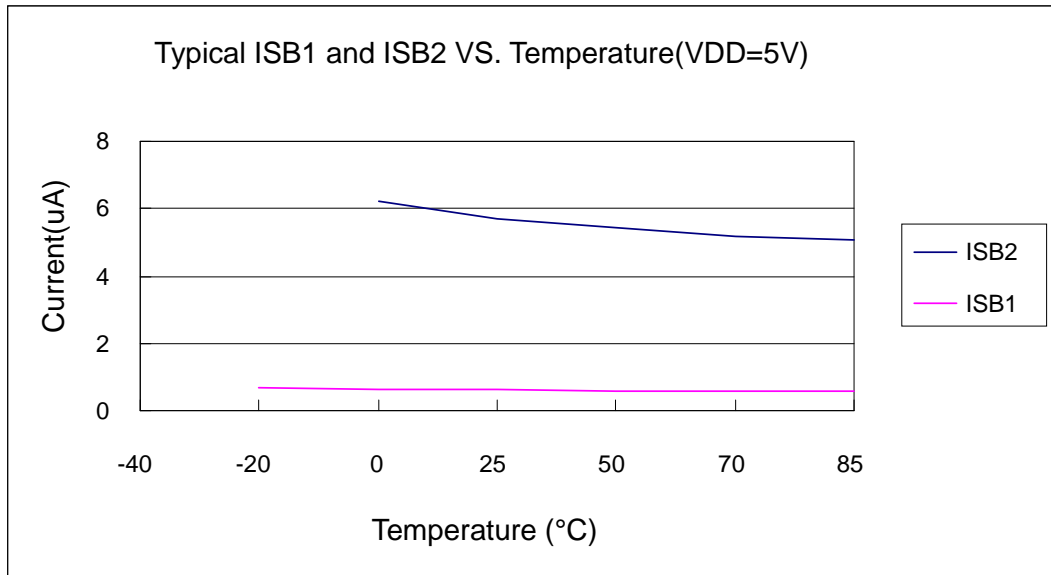

Figure 8-13 Typical Standby Current (VDD=5V) vs. Temperature

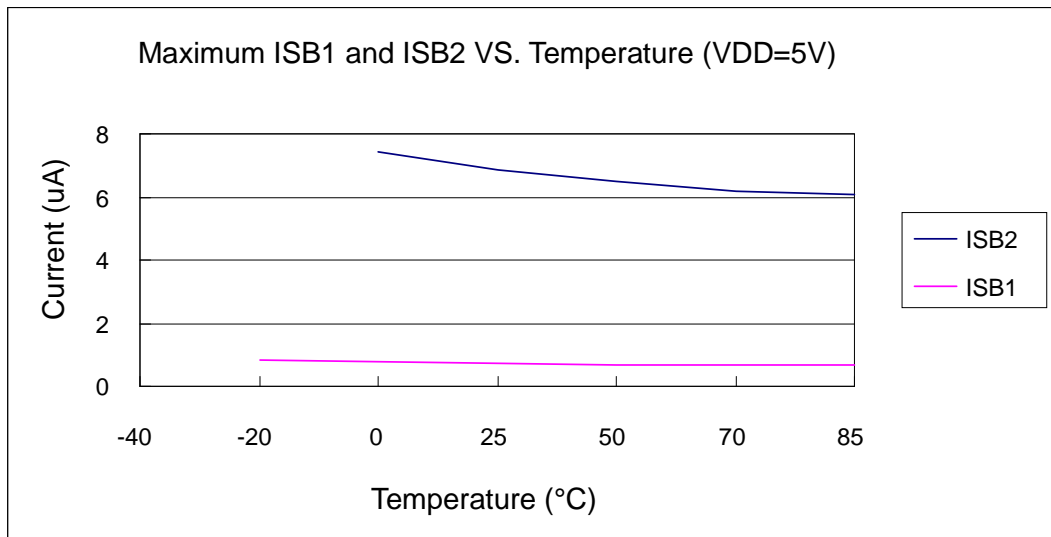

Figure 8-14 Maximum Standby Current (VDD=5V) vs. Temperature

Four conditions exist with the Operating Current ICC1 to ICC6. These conditions are as follows:

ICC1: Fosc = 32.768kHz, 2 clocks, WDT disable (Idle mode)

ICC2: Fosc = 32.768kHz, 2 clocks, WDT enable (Idle mode)

ICC4: Fosc = 32.768kHz, 2 clocks, WDT enable (Green mode)

ICC5: Fosc = 4 MHz, 2 clocks, WDT enable (Normal mode)

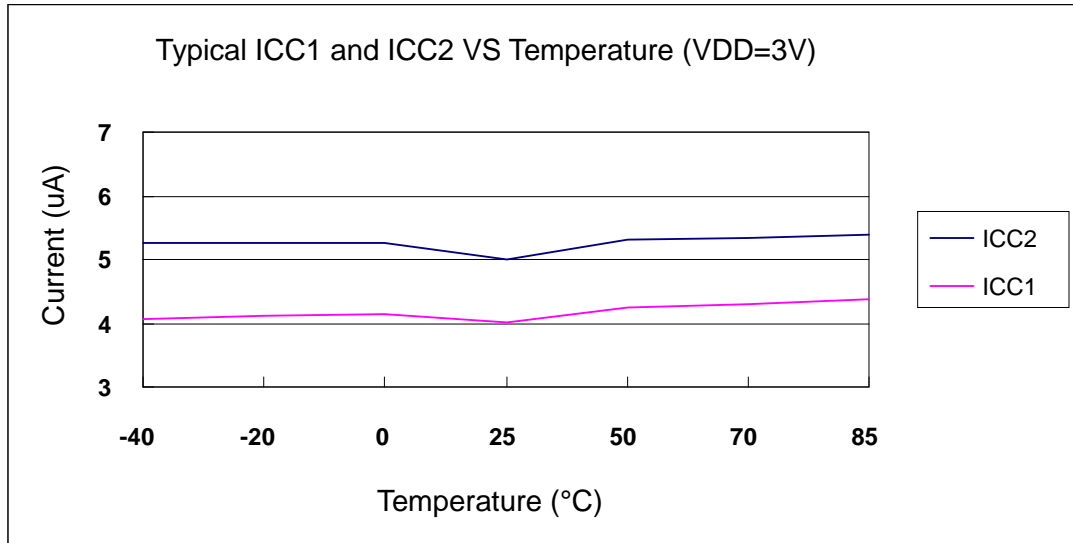

Figure 8-15 Typical Operating Current (VDD=3V) vs. Temperature

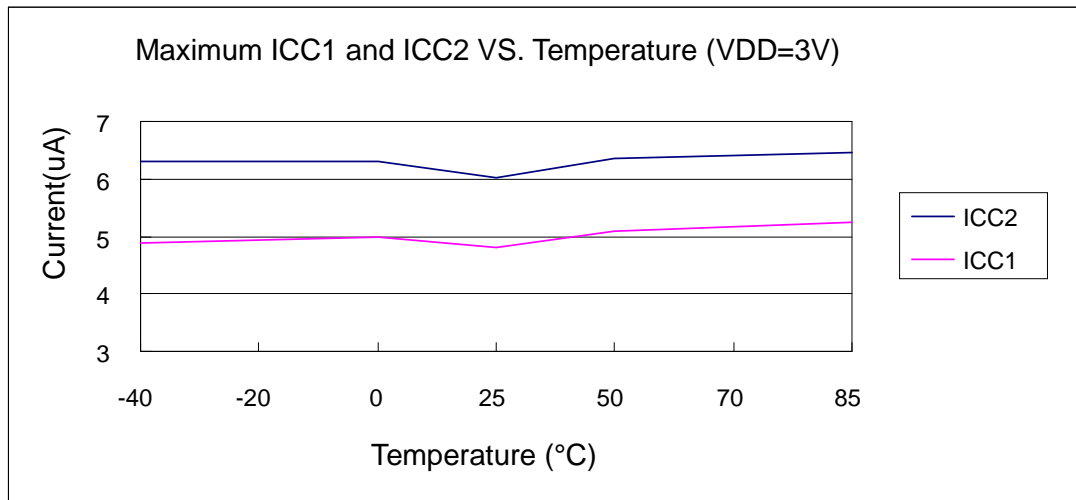

Figure 8-16 Maximum Operating Current (VDD=3V) vs. Temperature

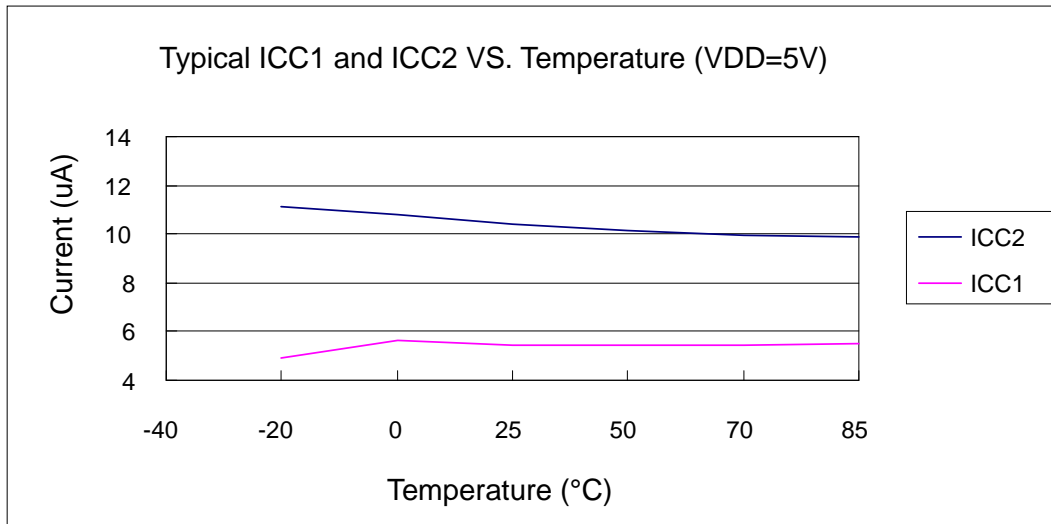

Figure 8-17 Typical Operating Current (VDD=5V) vs. Temperature

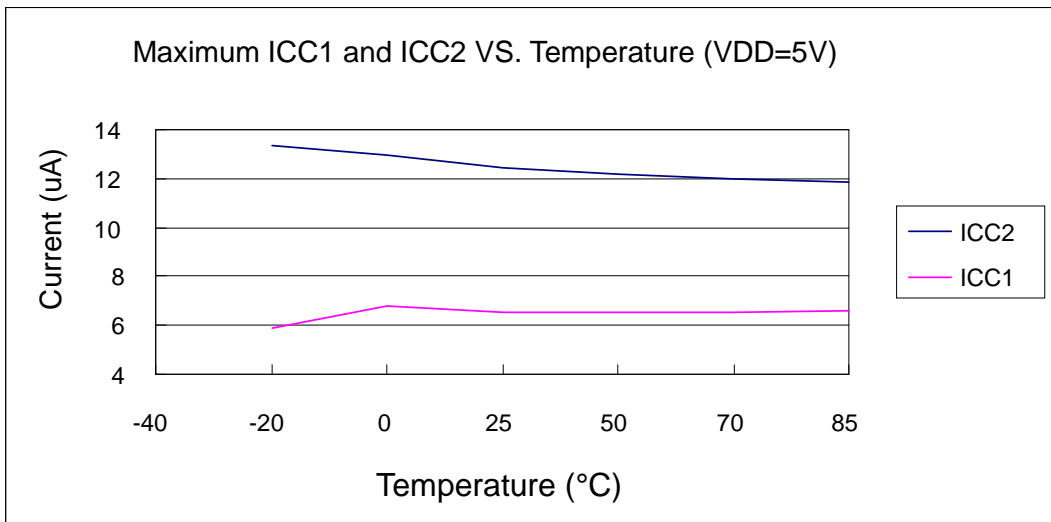

Figure 8-18 Maximum Operating Current (VDD=5V) vs. Temperature

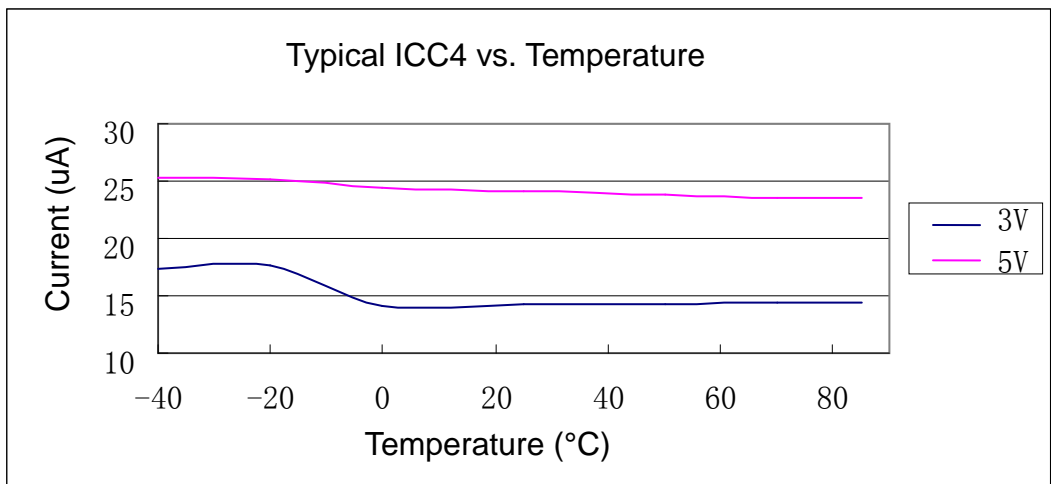

Figure 8-19 Typical Operating Current vs. Temperature

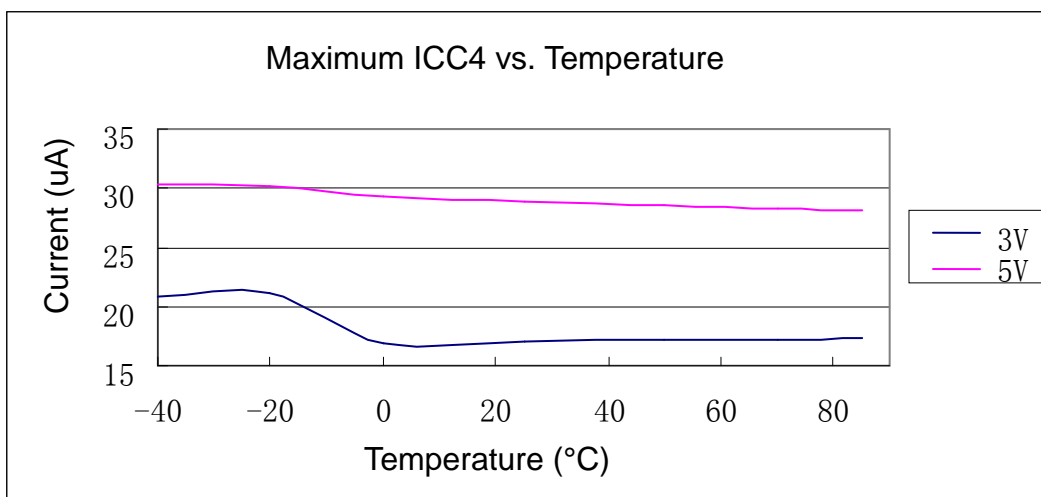

Figure 8-20 Maximum Operating Current vs. Temperature

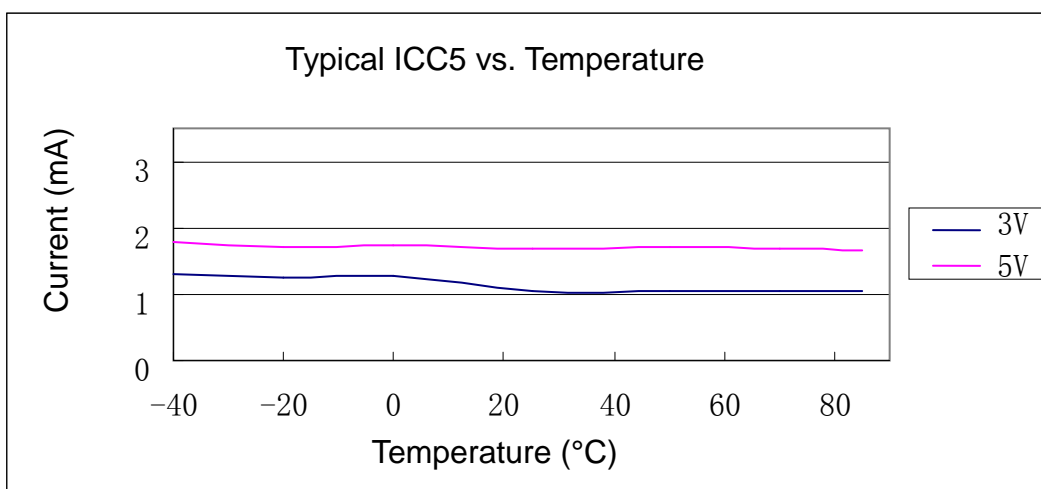

Figure 8-21 Typical Operating Current vs. Temperature

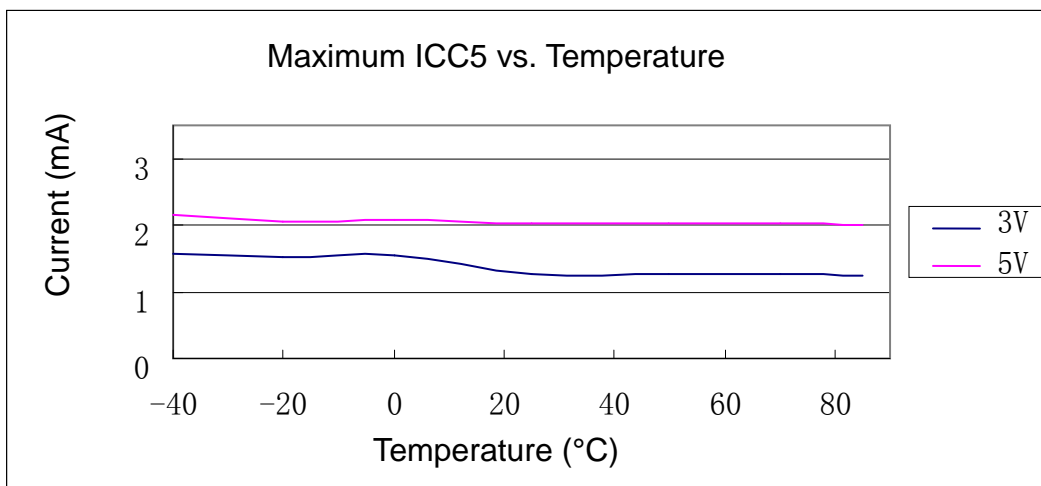

Figure 8-22 Maximum Operating Current vs. Temperature

9 AC Electrical Characteristics

■ (Ta = -40°C ~ 85°C, VDD = 5V ± 5%, GND = 0V)

Symbol	Parameter	Conditions	Min.	Typ.	Max.	Unit
Dclk	Input CLK duty cycle	–	45	50	55	%
Tins	Instruction cycle time (CLKS="0")	Crystal type	100	–	DC	ns
		RC type	500	–	DC	ns
Tdrh	Device reset hold time	Ta = 25°C	11.3	16.2	21.6	ms
Trst	/RESET pulse width	Ta = 25°C	2000	–	–	ns
Twdt	Watchdog timer period	Ta = 25°C	11.3	16.2	21.6	ms
Tset	Input pin setup time	–	–	0	–	ns
Thold	Input pin hold time	–	–	20	–	ns
Tdelay	Output pin delay time	Cload = 20pF	–	50	–	ns
Tiod	I/O delay for EMI enable	Cload = 150pF	4	5	6	ns

Note: These parameters are theoretical values and have not been tested.

10 Timing Diagrams

AC Test Input/Output Waveform

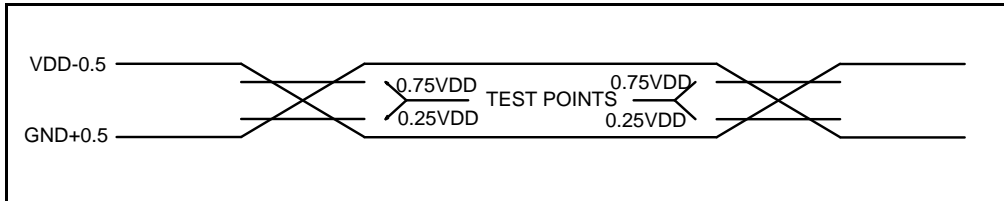

Note: AC Testing: Input are driven at $VDD-0.5V$ for logic "1," and $VSS+0.5V$ for logic "0"
Timing measurements are made at $0.75VDD$ for logic "1," and $0.25VDD$ for logic "0"

Figure 10-1a AC Test Input/Output Waveform Timing Diagram

Reset Timing (CLK="0")

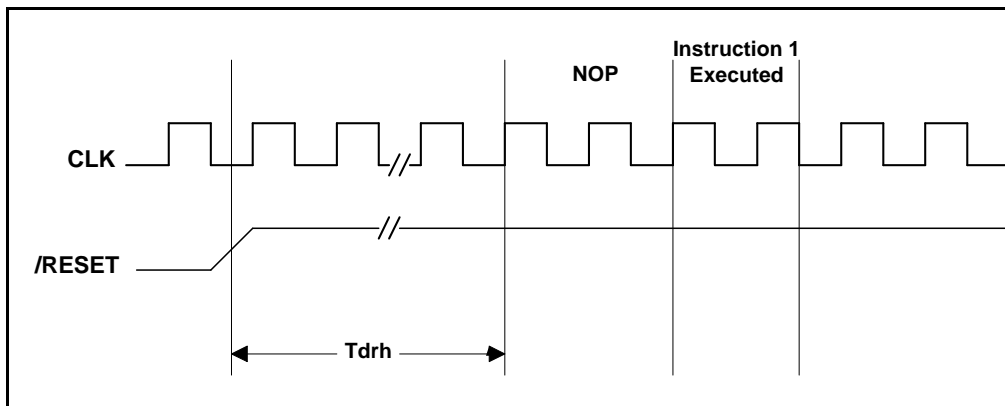
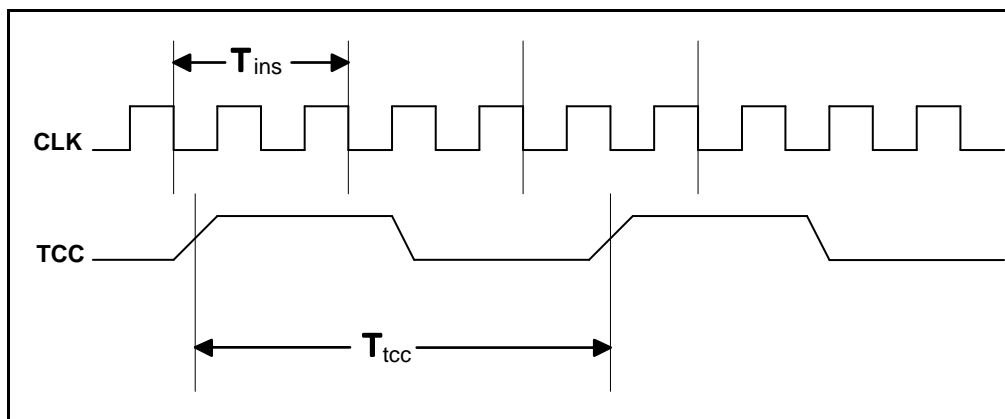

Figure 10-1b Reset Timing Diagram

TCC Input Timing (CLKS="0")



* $n = 0, 2, 4, 6$

Figure 10-1c TCC Input Timing Diagram

APPENDIX

A Ordering and Manufacturing Information

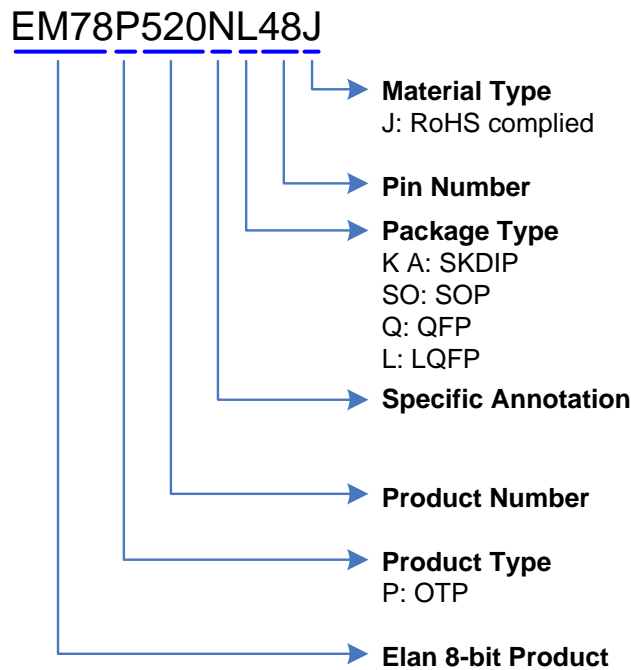

For example:

EM78P520NL48J

is EM78P520N with OTP program memory, industrial grade product, in 48-pin LQFP 7x7mm package with RoHS complied

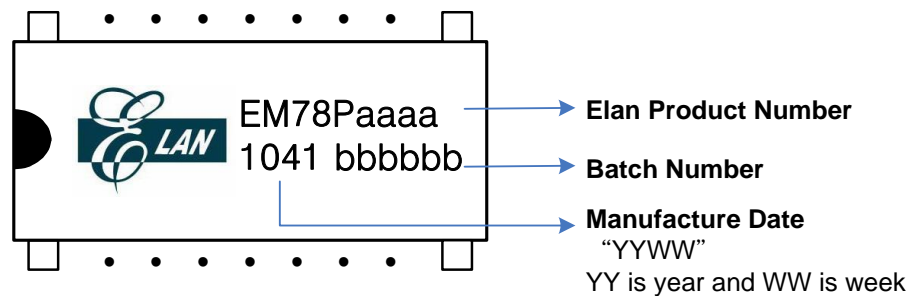

Ordering Code

EM78P520NL44J

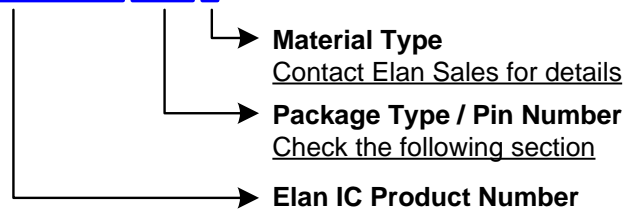

B Package Type

OTP MCU	Package Type	Pin Count	Package Size
EM78P520NQ44	QFP	44	10mm × 10mm
EM78P520NL44	LQFP	44	10mm × 10mm
EM78P520NL48	LQFP	48	7mm × 7mm

These are Green products which do not contain hazardous substances and comply with the third edition of Sony SS-00259 standard.

Pb content is less than 100ppm and complies with Sony specifications.

Part No.	EM78P520NxJ/xS
Electroplate type	Pure Tin
Ingredient (%)	Sn:100%
Melting point (°C)	232°C
Electrical resistivity ($\mu\Omega$ -cm)	11.4
Hardness (hv)	8~10
Elongation (%)	>50%

C Package Information

C.1 EM78P520NQ44

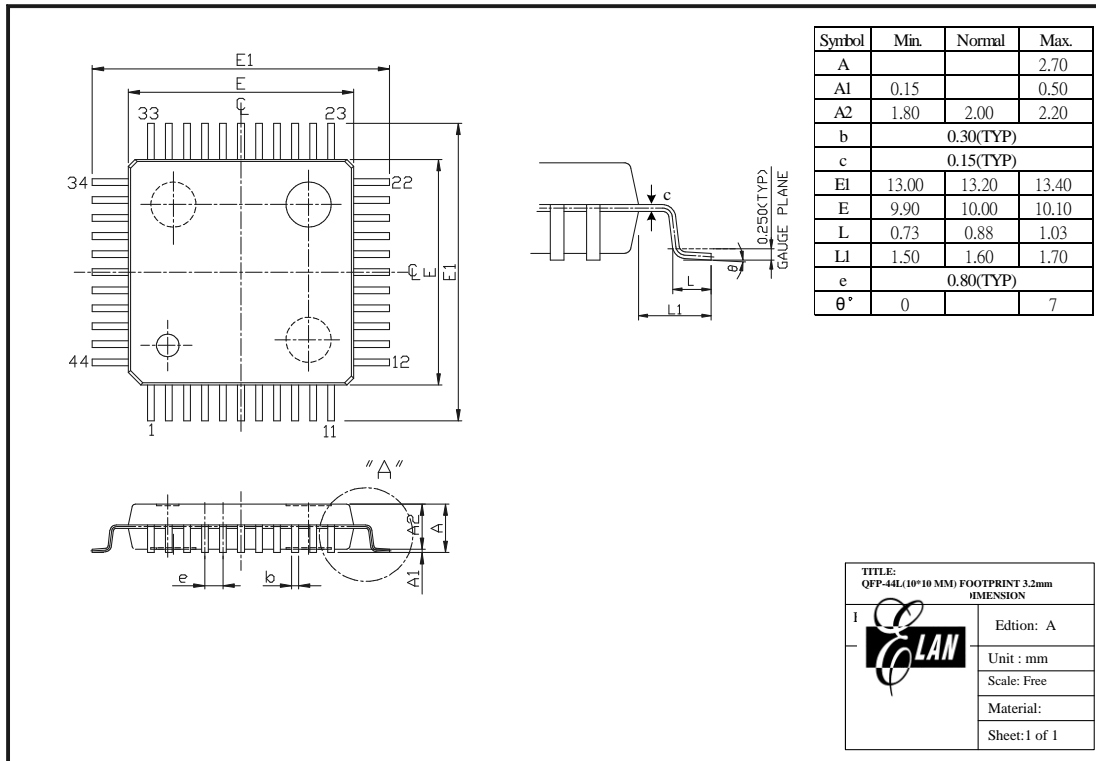

Figure B-3 EM78P520N 44-pin QFP Package Type

C.2 EM78P520NL44

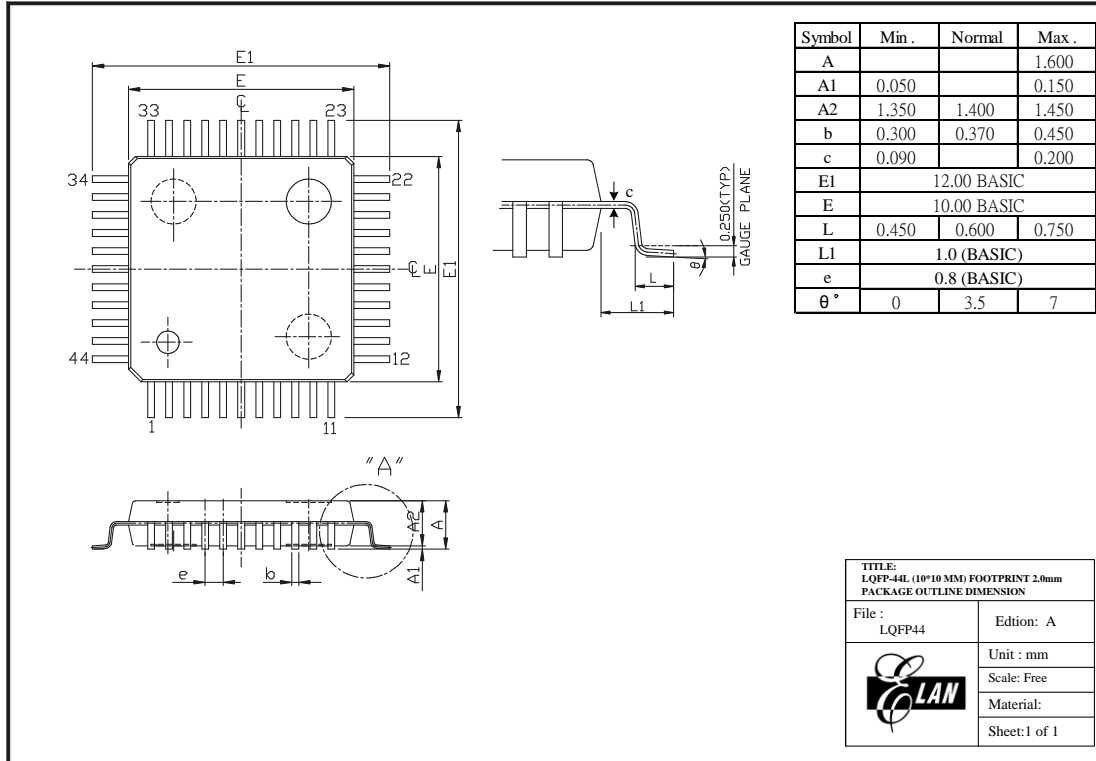

Figure B-4 EM78P520N 44-pin LQFP Package Type

C.3 EM78P520NL48

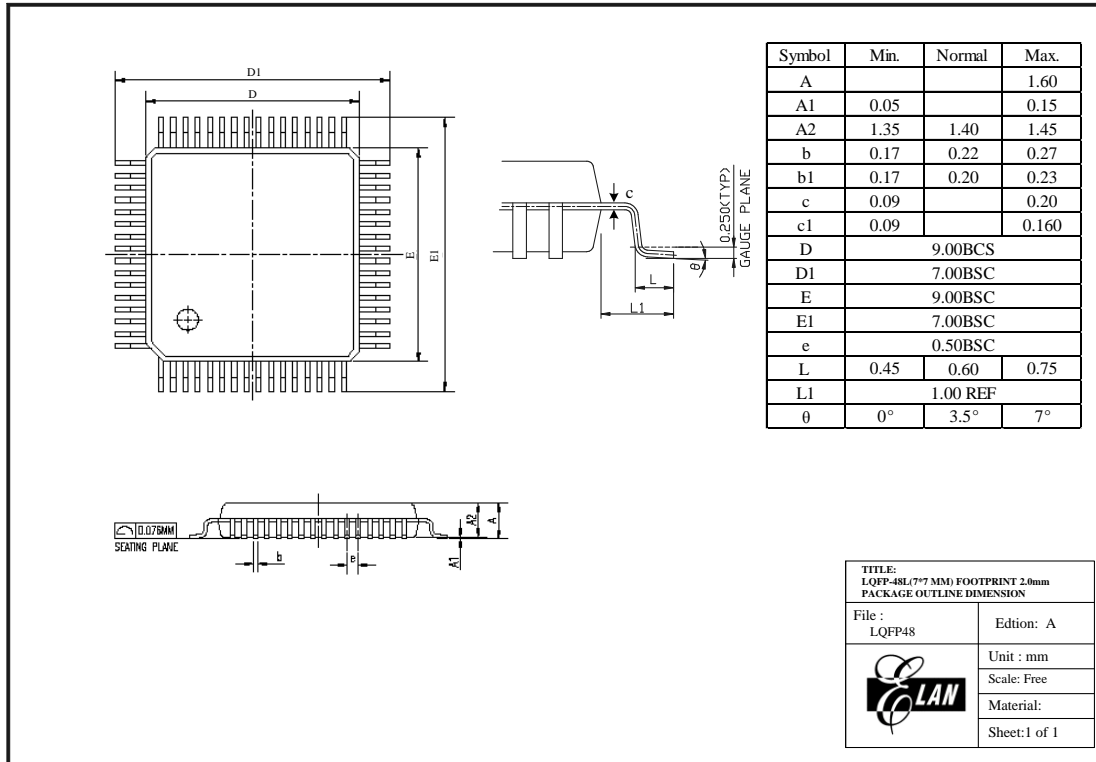

Figure B-5 EM78P520N 48-pin LQFP Package Type

D Quality Assurance and Reliability

Test Category	Test Conditions	Remarks
Solderability	Solder temperature= $245\pm 5^{\circ}\text{C}$, for 5 seconds up to the stopper using a rosin-type flux	
Pre-condition	Step 1: TCT, 65°C (15mins)~ 150°C (15min), 10 cycles	For SMD IC (such as SOP, QFP, SOJ, etc)
	Step 2: Bake at 125°C , TD (endurance) = 24 hrs	
	Step 3: Soak at $30^{\circ}\text{C}/60\%$, TD (endurance) = 192 hrs	
	Step 4: IR flow 3 cycles (Pkg thickness $\geq 2.5\text{mm}$ or Pkg volume $\geq 350\text{mm}^3$ ---- $225\pm 5^{\circ}\text{C}$) (Pkg thickness $\leq 2.5\text{mm}$ or Pkg volume $\leq 350\text{mm}^3$ ---- $240\pm 5^{\circ}\text{C}$)	
Temperature cycle test	-65°C (15min)~ 150°C (15min), 200 cycles	
Pressure cooker test	TA = 121°C , RH=100%, pressure = 2 atm, TD (endurance)= 96 hrs	
High temperature / High humidity test	TA= 85°C , RH=85%, TD (endurance) = 168, 500 hrs	
High-temperature storage life	TA= 150°C , TD (endurance) = 500, 1000 hrs	
High-temperature operating life	TA= 125°C , VDD=Max. operating voltage, TD (endurance) =168, 500, 1000 hrs	
Latch-up	TA= 25°C , VDD=Max. operating voltage, 150mA/20V	
ESD (HBM)	TA= 25°C , $\geq \pm 3\text{KV} $	IP_ND,OP_ND,IO_ND IP_NS,OP_NS,IO_NS IP_PD,OP_PD,IO_PD, IP_PS,OP_PS,IO_PS,
ESD (MM)	TA= 25°C , $\geq \pm 300\text{V} $	VDD-VSS(+),VDD_VSS (-) mode

D.1 Address Trap Detect

An address trap detect is one of the MCU embedded fail-safe functions that detects MCU malfunction caused by noise or the like. Whenever the MCU attempts to fetch an instruction from a certain section of ROM, an internal recovery circuit is auto started. If a noise caused address error is detected, the MCU will repeat execution of the program until the noise is eliminated. The MCU will then continue to execute the next program.

E EM78P520N Program Pin List

DWTR is used to program the EM78P520N IC's. The connector of DWTR is selected by CON3 (EM78P447). The software is selected by EM78P520N.

Program Pin Name	IC Pin Name	LQFP-48 Pin Number	L/QFP-44 Pin Number
Pin #31	P75	2	2
Pin #30	P76	3	3
Pin #28	P77	4	4
Pin #8	VDD	5	5
Pin #10	VSS	6	6
Pin #34	TEST	9	9
Pin #29	PC2	10	10
Pin #32	PC3	11	11

F ICE 520 Oscillator Circuit (JP4)

F.1 Mode 1

Main oscillator: Crystal mode, Sub oscillator: Crystal mode

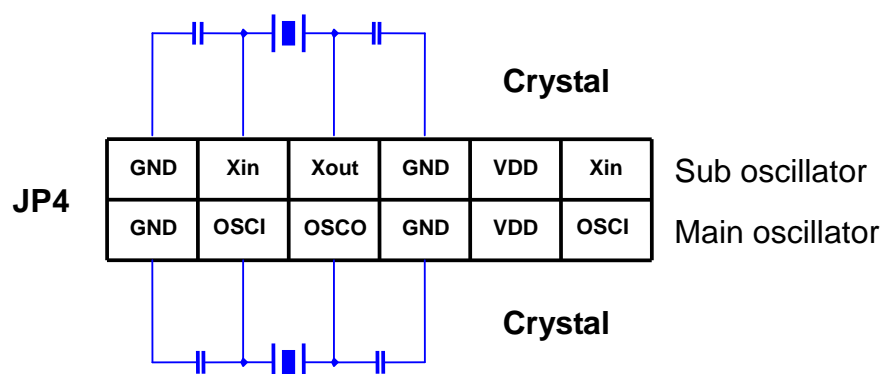

F.2 Mode 2

Main oscillator: PLL mode, Sub oscillator: Crystal mode

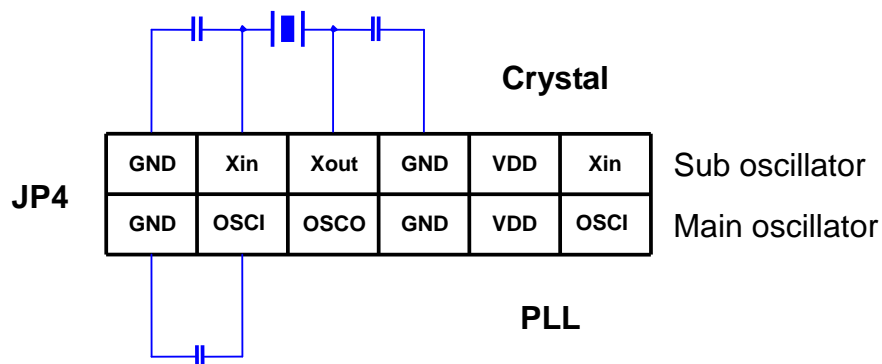

F.3 Mode 3

Main oscillator: ERIC mode, Sub oscillator: Crystal mode

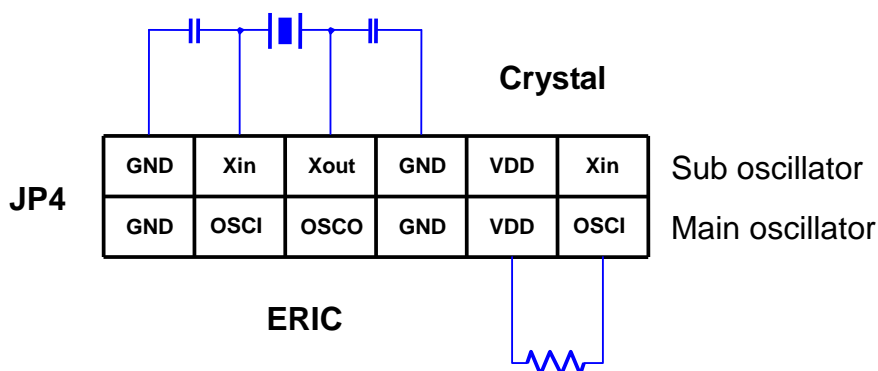

F.4 Mode 4

Main oscillator: Crystal mode, Sub oscillator: ERIC mode

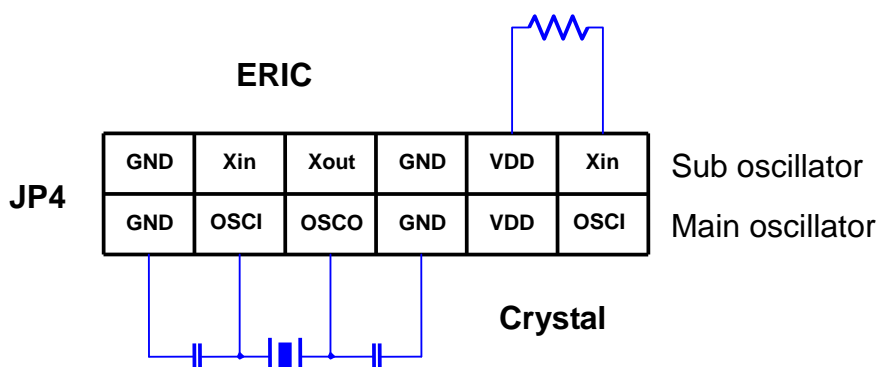

F.5 Mode 5

Main oscillator: PLL mode, Sub oscillator: RC mode

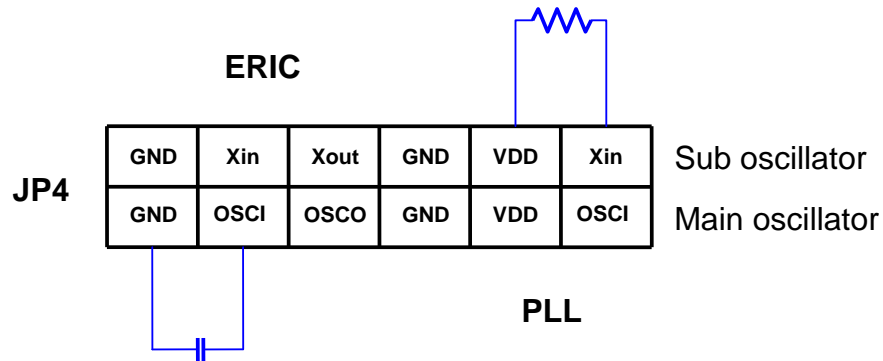

F.6 Mode 6

Main oscillator: RC mode, Sub oscillator: RC mode

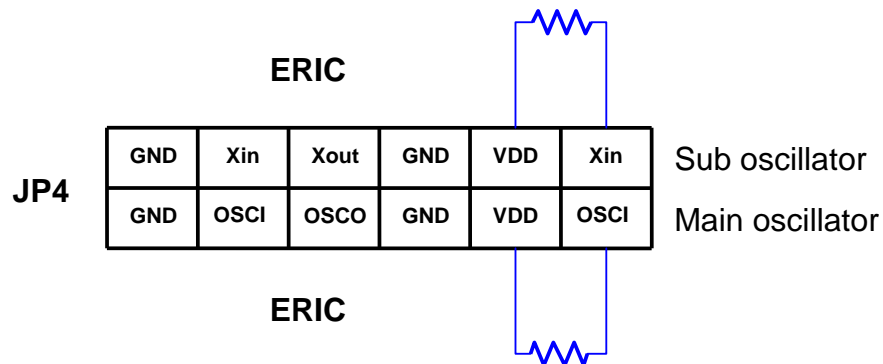

F.7 Mode 7

Main oscillator: Crystal mode, Sub oscillator: None

