



義隆電子股份有限公司

ELAN MICROELECTRONICS CORP.

---

# EM78P568

**8-BIT OTP MICRO-CONTROLLER**

Version 4.9

ELAN MICROELECTRONICS CORP.  
No. 12, Innovation 1<sup>st</sup> RD., Science-Based Industrial Park  
Hsin Chu City, Taiwan  
TEL: (03) 5639977  
FAX: (03) 5630118 (Elan SA2)

---



## Version History

Specification Revision History		
Version	Content	
EM78P568		
1.0	Initial version	2002/01/11
1.1	Change pin configuration	2002/04/08
1.2	Change pin configuration	2002/05/09
1.3	1.Update initial value of IOCA PAGE1 bit 3 from “x” to “0” 2.Change pin configuration on SEG20 ~ SEG28 pins locations	2002/05/16
2.0	1. Change R3 PAGE setting registers 2. Update register configuration and initial value tables 3. Add LCD waveform option bit. The new option : switch over LCD bias V1 and V2 for segments but bias remain unchanged for commons. 4.Modified pin configuration 5.Modified register setting	2002/06/12
2.1	Update error description and drawing	2002/06/19
2.2	Revise Fig.4 and Fig.5	2002/06/25
2.3	Change pin configuration	2002/08/30
2.4	Correct most of Figure #	2002/09/17
2.5	1. Change P73 interrupt setting from INT2 to INT3 2.Update pin configuration and pin description 3.Update relative RF, IOCF register bit description	2002/09/23
3.0	1.Add item 1 ~ 3 in the user application note (see user application note) 2.Clarity “not existent”, “unknown”or “undefined bits” descriptions. 3.Add LCD Type0 and Type1 waveform 4.Revised ROM size from 32kx13 to 16kx13 in the R2 description	2002/10/16
3.1	Change R3’s C,DC and Z flag status from “R” to “R/W”	2002/10/29
3.2	Fix bug in the application note	2002/10/31
3.3	1.Revise pin name of pin37,38 in the pin configuration figure 2.Revise description of IOC6 PAGE1 bit 0 ~ bit 1. 3.Add new application note on IOC6 PAGE1 bit 0 ~ bit 1.	2002/11/04
3.4	Revise test condition of electrical characteristic	2002/11/07
3.5	1.Update operating voltage of Comparator, DAC and CTCSS block in the feature description 2.Add DC voltage characteristic for 2.5VREF. 3.Revise sleep current max value from 8uA to 5uA. 4.add description in user application note	2002/11/22
3.6	1.Add DC characteristic under VDD=3V for 2.5VREF 2.Update description in user application note	2002/11/26
3.7	1.Update DC characteristic 2.Add effective VDD reference spec 3.Remove /POVD function 4.Update user application note	2002/11/29
3.8	1.Revised waveform of LCD 1/4 duty for Type 1 2.Revise CTCSS block figure	2003/01/15
3.9	1.Update DC characteristic for 2.5Vref spec and I/O port sink current spec. 2.Change OTP programming pin from P7(4~7) to P6(2~5) as following DINCK : change from P77 to P65 ACLK : change from p76 to P64 PGMB change from P75 to P63 OEB : change from P74 to P62	2003/02/12
4.0	1 Revise description in operating current for analog circuit 2.Revise dB to dBm on level for CTCSS tone to MTX	2003/10/24
4.1	1. Update application circuit Fig.23 2. Add VII.10 section	2004/07/15
4.5	1. Update VII.9, VII.10 sections 2. Add VII.11, VII.12, VII.13 sections	2004/07/15



	<ol style="list-style-type: none"><li>3. Update Fig.4, 5, 7, 10, 12, 14, 16, 18, 19, 20, 21</li><li>4. Add Fig.15, 22, 23</li><li>5. Make some figures with color</li><li>6. Add OSC and reset timing characteristic in page 52</li></ol>	
4.6	<ol style="list-style-type: none"><li>1. Add AC characteristic of AURX and MTX driving capacity for CTCSS block in page 52</li><li>2. Add AC characteristic of AURX and MTX output loading impedance for CTCSS block in page 52</li></ol>	2004/12/24
4.7	<ol style="list-style-type: none"><li>1. Update the title of VII.10 (3) and (4)</li><li>2. Revise Fig.23 bit location error</li><li>3. Update AC characteristics spec for CTCSS block</li><li>4. Add note on AC characteristics spec for CTCSS block item "Zero crossing threshold"</li><li>5. Add VII.10.2 and more descriptions in VII.10 section</li></ol>	2005/01/31
4.8	<ol style="list-style-type: none"><li>1. Add QFP 48 package</li></ol>	2006/07/14
4.9	<ol style="list-style-type: none"><li>1. Update description of IOCE PAGE1 bit2 (ASW3) and bit4 (ASW4)</li><li>2. Revise Fig.14</li><li>3. Remove bias description in VII.10.1</li><li>4. Revise CTCSS block and Fig.18 ~ Fig.21 in VII.10.1</li><li>5. Add VII.10.2 and VII.10.3 section</li><li>6. Update CTCSS block characteristic in XI. AC Electrical Characteristic</li><li>7. Revise the description of IOC5 page1 bit0~4 (CMP_B) at page 28</li><li>8. Remove QFP 48 package and add LQFP 48 package (EM78P568LFQ)</li><li>9. Add section Appendix. Package outline dimension</li></ol>	2007/01/17



## User Application Note

(Before using this chip, take a look at the following description note, it includes important messages.)

1. There are some undefined bits in the registers. The values in these bits are unpredicted. These bits are not allowed to use. We use the symbol “-” in the spec to recognize them.
2. You will see some names for the register bits definitions. Some name will be appear very frequently in the whole spec. The following describes the meaning for the register’s definitions such as bit type, bit name, bit number and so on.

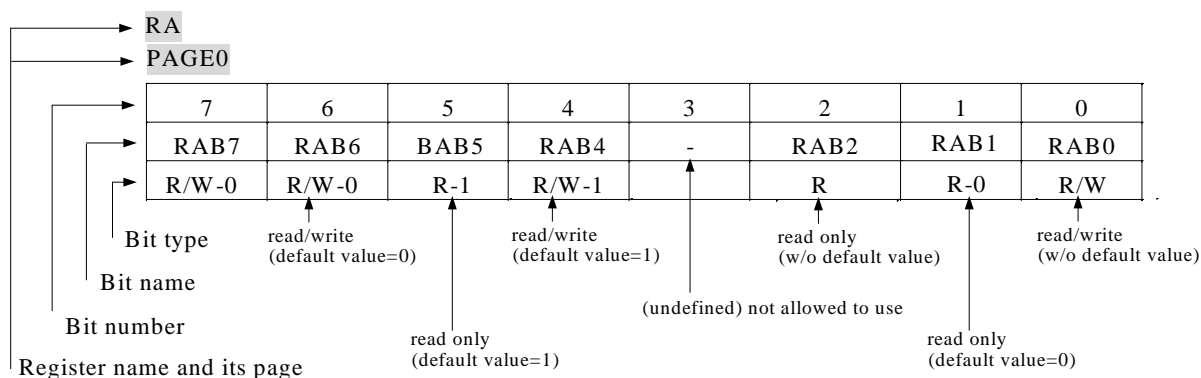

3. Let “IOCE PAGE0 Bit 4 ~ Bit 7” remain these values to “0” otherwise it will generate unpredicted interrupts.
4. Let “IOCC PAGE1 Bit 0” remain its value to “0” unchanged otherwise Comparator and CTCSS function will fail.
5. Let IOC6 PAGE1 bit 0 ~ Bit 1 remain these values to “0” unchanged if PORT60,61 are used.
6. Please set RA PAGE2 bit 7 to “1” to get better LCD display performance while LCD driver is used.
7. The difference between EM78568 and EM78P568.

### Function

Item	EM78568	EM78P568
Data RAM	0.5k x 8	1k x 8
I/O	PC0	PC0 ~ PC7 PB0 ~ PB7
LCD driver	SEG0 ~ SEG19	SEG0 ~ SEG31
Package	100-pin QFP, 63-pin die	100-Pin QFP, 48-pin LQFP, 78-pin die

### DC characteristic

Parameter	Symbol	Condition	Min	Typ	Max	Unit
Internal 2.5V ref. Voltage	2.5VREF	VDD=5V, 25 deg for EM78568	2.32	2.46	2.58	V
		VDD=5V, 25 deg for EM78P568	2.14	2.32	2.44	V
		VDD=3V, 25 deg for EM78568	2.22	2.36	2.48	V
		VDD=3V, 25 deg for EM78P568	2.04	2.25	2.36	V



義隆電子股份有限公司

ELAN MICROELECTRONICS CORP.

---

8. *In the feature description CPU operating voltage 2.2 ~ 5.5V, the minimum operating voltage 2.2V is under maximum main clock = 3.5826MHz.*

---



## I. General Description

The EM78P568 is an 8-bit RISC type microprocessor with low power, high speed CMOS technology. There are 16Kx13 bits Electrical One Time Programmable Read Only Memory (OTP-ROM) within it. It provides security bits and some One time programmable Option bits to protect the OTP memory code from any external access as well as to meet user's options.

This integrated single chip has an on\_chip watchdog timer (WDT), program OTP-ROM, data RAM, LCD driver, programmable real time clock/counter, internal interrupt, power down mode, 8-bit D/A, 5-bit Comparator, DAC tone generator, CTCSS analog circuit, programming dual tone generator and tri-state I/O.

## II. Feature

### CPU

- Operating voltage : 2.2V~5.5V
- 16k x 13 on chip Electrical One Time Programmable Read Only Memory (OTP-ROM)
- 1k x 8 on chip data RAM
- Up to 51 bi-directional tri-state I/O ports
- 16 level stack for subroutine nesting
- 8-bit real time clock/counter (TCC)
- two 8-bit counters : COUNTER1 and COUNTER2
- On-chip watchdog timer (WDT)
- 99.9% single instruction cycle commands
- Four modes (Main clock can be programmed from 447.829k to 17.913MHz generated by internal PLL)

Mode	CPU status	Main clock	32.768kHz clock status
Sleep mode	Turn off	Turn off	Turn off
Idle mode	Turn off	Turn off	Turn on
Green mode	Turn on	Turn off	Turn on
Normal mode	Turn on	Turn on	Turn on

- Input port interrupt function
- 8 interrupt source, 4 external, 8 internal
- Dual clocks operation (Internal PLL main clock , External 32.768KHz)

### PROGRAMMING TONE GENERATORS

- Operating voltage : 2.2V~5.5V
- Programming Tone1 and Tone2 dual tone generators
- 11-bit programming Tone1 generators
- 8-bit programming Tone2 generator

### COMPARATOR

- Operating : 2.7V ~ 5.5V
- 3-channel input
- 5-bit comparison reference level setting
- Internal (2.5V or VDD) or external reference level

### DAC

- Operating : 2.7V~5.5V
- 8-bit R-2R D/A converter
- 8-bit programmable tone output
- Easy to direct access as programmable CTCSS tone output by DAC tone generator
- Internal (VDD or 2.5V) reference



#### CTCSS block

- Operating voltage : 2.7V ~ 5.5V
- Microphone amplifier (can be used as general OP Amp)
- Microphone mute function
- RX input OP
- Audio BPF (300Hz ~ 3400Hz)
- Sub-audio LPF (60Hz ~ 253Hz) for CTCSS tone detection
- Zero-crossing for detected CTCSS tone frequency output
- CTCSS Tx modulation summing Amp

#### LCD

- Common driver pins : 4
- Segment driver pins : 32
- 1/3 bias
- 1/4 duty, 1/2 duty
- 16 Level LCD contrast control by software

#### PACKAGE

- 100-pin QFP (EM78P568AQ)
- 48-pin LQFP (EM78P568LFQ)
- 78-pin die (EM78P568H)

### III. Application

FRS (Family Radio Systems) ,other wireless and portable products,



## IV. Pin Configuration

	100	99	98	97	96	95	94	93	92	91	90	89	88	87	86	85	84	83	82	81			
	SEG1	SEG2	SEG3	SEG4	SEG5	SEG6	SEG7	SEG8	SEG9	SEG10/P55	SEG11/P56	SEG12/P57	SEG13/P97	SEG14/P96	SEG15/P95	SEG16/P94	SEG17/P93	SEG18/P92	SEG19/P91	SEG20/P90			
NC	1																				80	NC	
NC	2																					79	NC
NC	3																					78	NC
NC	4																					77	NC
NC	5																					76	NC
NC	6																					75	SEG21/PB7
NC	7																					74	SEG22/PB6
NC	8																					73	SEG23/PB5
NC	9																					72	SEG24/PB4
SEG0	10																					71	SEG25/PB3
COM3	11																					70	SEG26/PB2
COM2	12																					69	SEG27/PB1
COM1	13																					68	SEG28/PB0
COM0	14																					67	SEG29/PC7
NC	15																					66	SEG30/PC6
NC	16																					65	SEG31/PC5
NC	17																					64	PC4
NC	18																					63	PC3
NC	19																					62	PC2
NC	20																					61	PC1
AVDD	21																					60	PC0
RXO	22																					59	INT0/P70
RXI	23																					58	INT1/P71
NC	24																					57	INT2/P72
NC	25																					56	INT3/P73
MIC1	26																					55	P74
MICO	27																					54	P75
TONE	28																					53	P76
PLL	29																					52	P77
AVSS	30																					51	VDD
		31																					
DAO/P67																							
MTX/P66																							
AURX/P65																							
CMP3/P64																							
CMP2/P63																							
CMP1/P62																							
							P61																
							P60																
							P87																
							P86																
							P85																
							P84																
							XIN																
							XOUT																
							VSS																
							P84																
							P83																
							P82																
							P81																
							P80																
							/RESET																
							50																

100-pin QFP



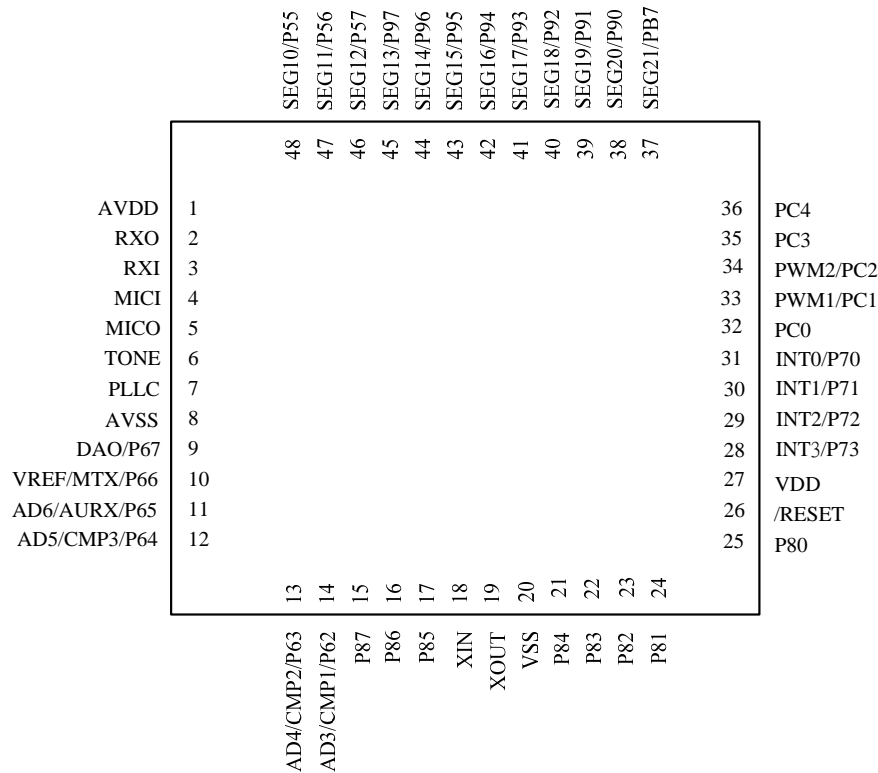

48-pin LQFP

Fig.1 Pin assignment

(please refer Appendix. Package outline dimension)

OTP PIN NAME	MASK ROM PIN NAME	P.S.
VDD	VDD,AVDD	
VPP	/RESET	
DINCK	P65	
ACLK	P64	
PGMB	P63	
OEB	P62	
DATA	P73	
GND	VSS,AVSS	

### V. Functional Block Diagram

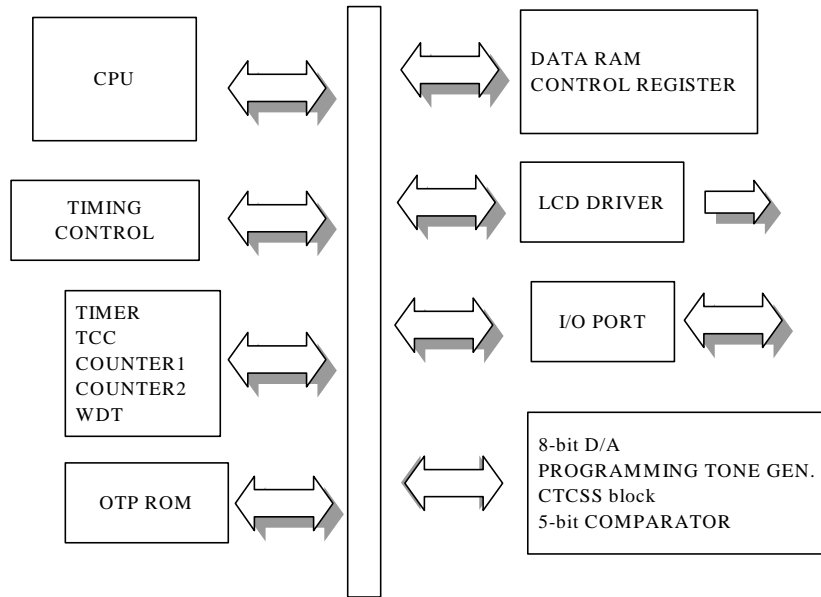

Fig.2a Block diagram

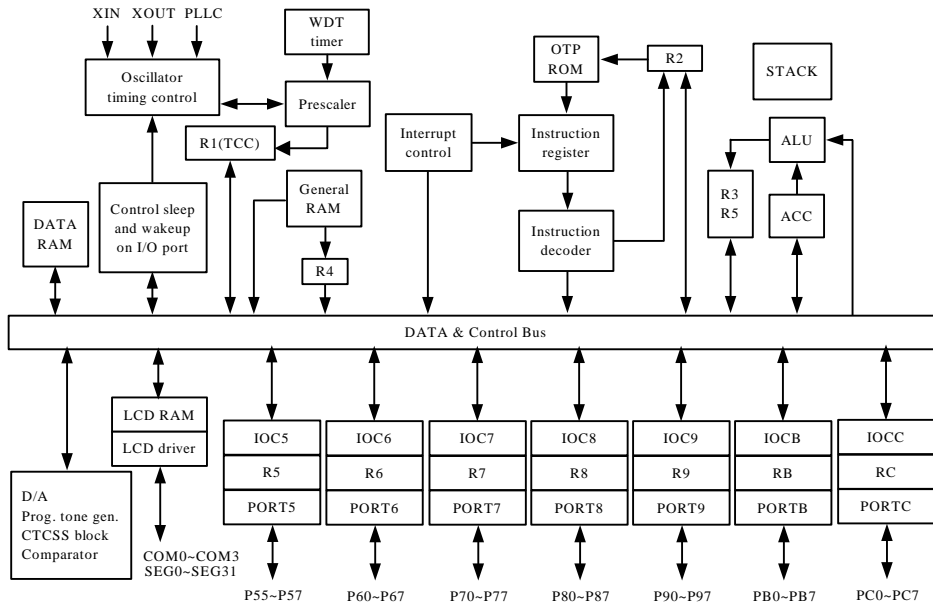

Fig.2b Block diagram

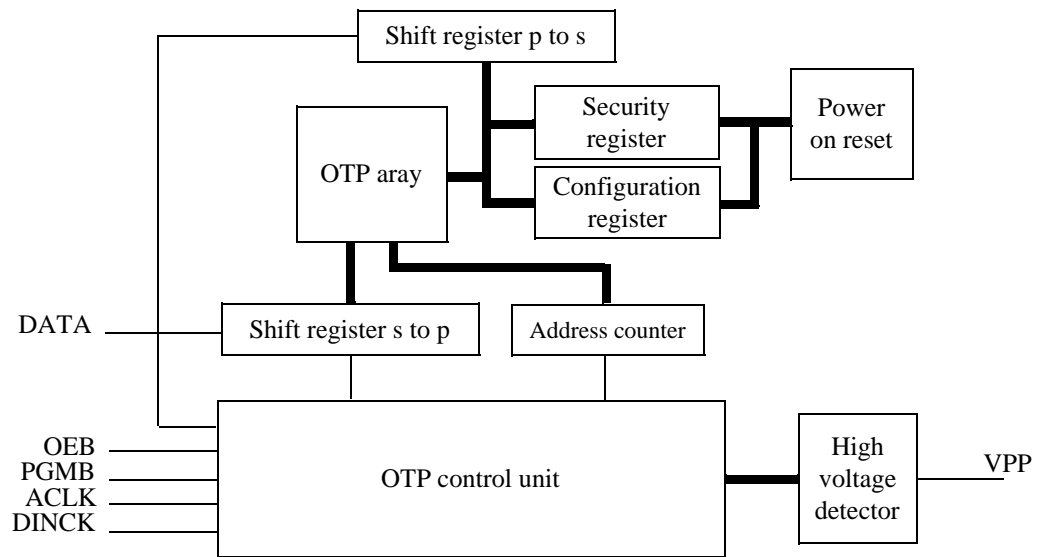

Fig.2c Block diagram for OTP function



## VI. Pin Descriptions

PIN	I/O	DESCRIPTION
<b>POWER</b>		
VDD	POWER	Digital power
AVDD		Analog power
VSS	POWER	Digital ground
AVSS		Analog ground
<b>CLOCK</b>		
XIN	I	Input pin for 32.768 kHz oscillator
XOUT	O	Output pin for 32.768 kHz oscillator
PLLC	I	Phase loop lock capacitor, connect a capacitor 0.01u to 0.047u to the ground.
<b>LCD</b>		
COM0 ~ COM3	O	Common driver pins of LCD drivers
SEG0 ~ SEG9	O	Segment driver pins of LCD drivers SEG10 to SEG31 are shared with IO PORT.
SEG10 ~ SEG12	O (I/O : PORT5)	
SEG13 ~ SEG20	O (I/O : PORT9)	
SEG21 ~ SEG28	O (I/O : PORTB)	
SEG29 ~ SEG31	O (I/O : PORTC)	
<b>Programming tone generators</b>		
TONE	O	Programming single tone or dual tone output
<b>Comparator</b>		
CMP1	I (P62)	Comparator input pins. Shared with PORT62, PORT634 and PORT64.
CMP2	I (P63)	
CMP3	I (P64)	
<b>8-bit D/A</b>		
DAO	O (P67)	D/A converter output pin. Shared with PORT67
<b>CTCSS</b>		
MICO	O	Microphone amplifier output. Put a feedback resistor to adjust the gain
MICI	I	Microphone amplifier input
RXO	O	Receiver amplifier output. Put a feedback resistor to adjust the gain
RXI	I	Receiver amplifier input
AURX	O (P65)	Receiving audio output Share with PORT65
MTX	O (P66)	Modulation transmission output for CTCSS tone Shared with PORT66
<b>IO</b>		
P55~P57	I/O	PORT5 can be INPUT or OUTPUT port each bit. PORT5(7:5) are shared with LCD Segment signal.
P60 ~P67	I/O	PORT6 can be INPUT or OUTPUT port each bit.
P70 ~ P77	I/O	PORT7 can be INPUT or OUTPUT port each bit. PORT7(4~6) are shared with SPI interface pins Internal Pull high function. PORT7(0~3) has interrupt function.



P80 ~ P87	I/O	PORT8 can be INPUT or OUTPUT port each bit. Internal pull high. PORT85 ~ P87 are shared with ADC input PORT8(0~3) have wake-up functions(set by RE PAGE0)
P90 ~ P97	I/O	PORT9 can be INPUT or OUTPUT port each bit. PORT9 are shared with LCD Segment signal.
PB0 ~ PB7	I/O	PORTB can be INPUT or OUTPUT port each bit. PORTB are shared with LCD Segment signal.
PC0 ~ PC7	I/O	PORTC can be INPUT or OUTPUT port each bit. PORTC(7:5) are shared with LCD Segment signal.
INT0	(PORT70)	Interrupt sources. Once PORT70 has a falling edge or rising edge signal (controlled by CONT register), it will generate a interruption.
INT1	(PORT71)	Interrupt sources which has the same interrupt flag. Any pin from PORT71 has a falling edge signal, it will generate a interruption.
INT2	(PORT72)	Interrupt sources which has the same interrupt flag. Any pin from PORT72 has a falling edge signal, it will generate a interruption.
INT3	(PORT73)	Interrupt sources which has the same interrupt flag. Any pin from PORT73 has a falling edge signal, it will generate a interruption.
/RESET	I	Low reset



## VII. Functional Descriptions

### VII.1 Operational Registers

#### Register configuration

Addr	R PAGE registers			
	R PAGE0	R PAGE1	R PAGE2	
00	Indirect addressing			
01	TCC			
02	PC			
03	Page, Status			
04	RAM bank, RSR			
05	Port5 I/O data, Program ROM page			LCD RAM address
06	Port6 I/O data			LCD RAM data buffer
07	Port7 I/O data			CTCSS detection output, Data RAM bank
08	Port8 I/O data			Data RAM address
09	Port9 I/O data			Data RAM data buffer
0A	PLL, Main clock, Comparator flag, WDTE	DAC input data buffer	LCD waveform option	
0B	PortB I/O data			
0C	PortC I/O data			Counter1 data
0D	LCD control			Counter2 data
0E	Wake-up control, Interrupt flag			DAC tone selection
0F	Interrupt flag			
10	16 bytes			
:	Common registers			
1F				
20	Bank0~Bank3			
:	Common registers			
3F	(32x8 for each bank)			

Addr	IOC PAGE registers	
	IOC PAGE0	IOC PAGE1
00		
01		
02		
03		
04		
05	Port5 I/O control, LCD bias control	Comparator control
06	Port6 I/O control	Port6 switches
07	Port7 I/O control	Port7 pull high
08	Port8 I/O control	Port8 pull high

\* This specification are subject to be changed without notice.



09	Port9 I/O control	Port9 switches
0A	TONE2 control	DAC,DAC tone control, 2.5V ref control
0B	PortB I/O control	
0C	PortC I/O control	Port5,8,B,C switch
0D	TONE1 control	Clock source(CN1,CN2) Prescaler(CN1,CN2)
0E	TONE1 extra control, Interrupt mask	CTCSS control switches
0F	Interrupt mask	
10		
:		
1F		
20		
:		
3F		

## VII.2 Operational Register Detail Description

### R0 (Indirect Addressing Register)

R0 is not a physically implemented register. It is used as indirect addressing pointer. Any instruction using R0 as register actually accesses data pointed by the RAM Select Register (R4).

Example:

```
Mov  A, @0x20      ;store a address at R4 for indirect addressing
Mov  0x04, A
Mov  A, @0xAA      ;write data 0xAA to R20 at bank0 through R0
Mov  0x00, A
```

### R1 (TCC)

TCC data buffer. Increased by 16.384KHz or by the instruction cycle clock (controlled by CONT register).  
Written and read by the program as any other register.

### R2 (Program Counter)

The structure is depicted in Fig.3.

Generates  $16k \times 13$  on-chip PROGRAM OTP-ROM addresses to the relative programming instruction codes.

"JMP" instruction allows the direct loading of the low 10 program counter bits.

"CALL" instruction loads the low 10 bits of the PC, PC+1, and then push into the stack.

"RET" ("RETL k", "RETI") instruction loads the program counter with the contents at the top of stack.

"MOV R2, A" allows the loading of an address from the A register to the PC, and the ninth and tenth bits are cleared to "0".

"ADD R2,A" allows a relative address be added to the current PC, and contents of the ninth and tenth bits are cleared to "0".

"TBL" allows a relative address added to the current PC, and contents of the ninth and tenth bits don't change. The most significant bit (A10~A13) will be loaded with the contents of bit PS0~PS3 in the status register (R5 PAGE0) upon the execution of a "JMP", "CALL", "ADD R2, A", or "MOV R2, A" instruction.

If an interrupt is triggered, PROGRAM ROM will jump to address 0x08 at page0. The CPU will store ACC, R3 status and R5 PAGE automatically, and they will be restored after instruction RETI.

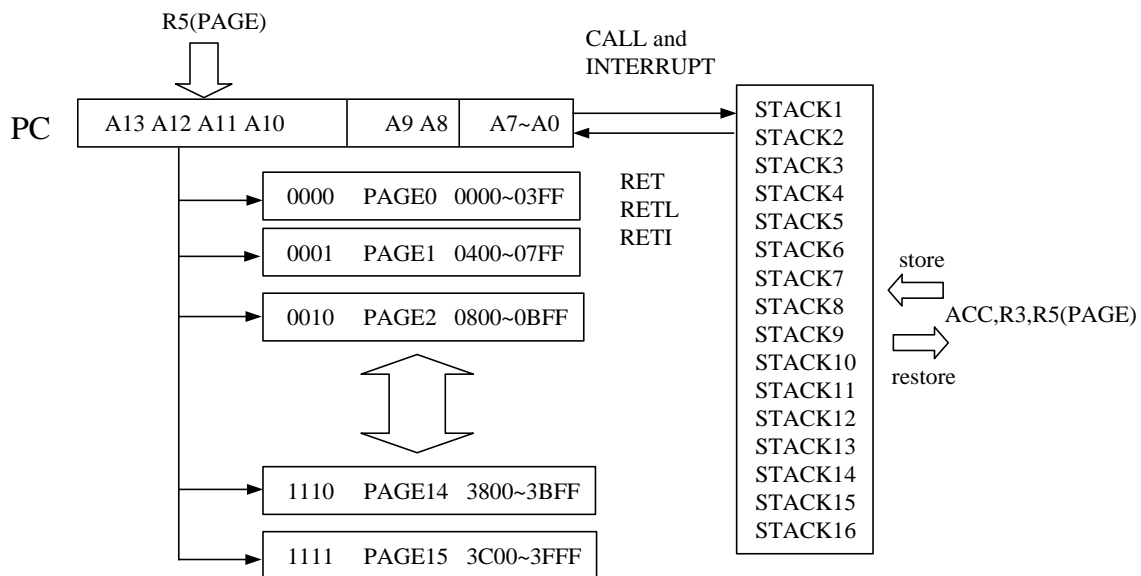

Fig.3 Program counter organization

### R3 (Status, Page selection)

(Status flag, Page selection bits)

7	6	5	4	3	2	1	0
RPAGE2	RPAGE	IOCPAGE	T	P	Z	DC	C
R/W-0	R/W-0	R/W-0	R	R	R/W	R/W	R/W

Bit 0(C) : Carry flag

Bit 1(DC) : Auxiliary carry flag

Bit 2(Z) : Zero flag

Bit 3(P) : Power down bit

Set to 1 during power on or by a "WDTC" command and reset to 0 by a "SLEP" command.

Bit 4(T) : Time-out bit

Set to 1 by the "SLEP" and "WDTC" command, or during power up and reset to 0 by WDT timeout.

EVENT	T	P	REMARK
WDT wake up from sleep mode	0	0	
WDT time out (not sleep mode)	0	1	
/RESET wake up from sleep	1	0	
Power up	1	1	
Low pulse on /RESET	x	X	x : don't care

Bit 5(IOCPAGE) : change IOC5 ~ IOCE to another page

0/1 → IOC page0 / IOC page1

Please refer to VII.1 Operational registers for detail IOC PAGE register configuration.

Bit 6 ~ Bit 7 (RPAGE0 ~ RPAGE1) : change R5 ~ RE to another page

(RPAGE1,RPAGE0)	R page # selected
(0,0)	R page 0
(0,1)	R page 1
(1,0)	R page 2
(1,1)	R page 3



Please refer to VII.1 Operational registers for detail R PAGE register configuration.

#### R4 (RAM selection for common registers R20 ~ R3F))

(RAM selection register)

7	6	5	4	3	2	1	0
RB1	RB0	RSR5	RSR4	RSR3	RSR2	RSR1	RSR0
R/W-0	R/W-0	R/W	R/W	R/W	R/W	R/W	R/W

Bit 0 ~ Bit 5 (RSR0 ~ RSR5) : Indirect addressing for common registers R20 ~ R3F

RSR bits are used to select up to 32 registers (R20 to R3F) in the indirect addressing mode.

Bit 6 ~ Bit 7 (RB0 ~ RB1) : Bank selection bits for common registers R20 ~ R3F

These selection bits are used to determine which bank is activated among the 4 banks for 32 register (R20 to R3F)..

Please refer to VII.1 Operational Registers for details.

#### R5 (PORT5 I/O data, Program page selection, LCD address)

PAGE0 (PORT5 I/O data register, Program page register)

7	6	5	4	3	2	1	0
P57	P56	P55	-	PS3	PS2	PS1	PS0
R/W	R/W	R/W		R/W-0	R/W-0	R/W-0	R/W-0

Bit 0 ~ Bit 3 (PS0 ~ PS3) : Program page selection bits

PS3	PS2	PS1	PS0	Program memory page (Address)
0	0	0	0	Page 0
0	0	0	1	Page 1
0	0	1	0	Page 2
0	0	1	1	Page 3
:	:	:	:	:
:	:	:	:	:
1	1	1	0	Page 14
1	1	1	1	Page 15

User can use PAGE instruction to change page to maintain program page by user. Otherwise, user can use far jump (FJMP) or far call (FCALL) instructions to program user's code. And the program page is maintained by EMC's compiler. It will change user's program by inserting instructions within program.

Bit 4 : (undefined) not allowed to use

Bit 5 ~ Bit 7 (P55 ~ P57) : 8-bit PORT5(5~7) I/O data register

User can use IOC register to define input or output each bit.

PAGE1 (LCD address)

7	6	5	4	3	2	1	0
-	-	-	-	LCDA3	LCDA2	LCDA1	LCDA0
				R/W-0	R/W-0	R/W-0	R/W-0

Bit 0 ~ Bit 3 (LCDA0 ~ LCDA3) : LCD address for LCD RAM read or write

The address of the LCD RAM correspond to the COMMON and SEGMENT signals as the table.

COM3 ~ COM0	LCD address (LCDA3 ~ LCDA0)
SEG1, SEG0	00H
SEG3, SEG2	01H
SEG5, SEG4	02H
SEG7, SEG6	03H



SEG9, SEG8	04H
SEG11, SEG10	05H
SEG13, SEG12	06H
SEG15, SEG14	07H
SEG17, SEG16	08H
SEG19, SEG18	09H
SEG21, SEG20	0AH
SEG23, SEG22	0BH
SEG25, SEG24	0CH
SEG27, SEG26	0DH
SEG29, SEG28	0EH
SEG31, SEG30	0FH

Bit 4 ~ Bit 7 : (undefined) not allowed to use

### R6 (PORT6 I/O data, LCD data)

#### PAGE0 (PORT6 I/O data register)

7	6	5	4	3	2	1	0
P67	P66	P65	P64	P63	P62	P61	P60
R/W	R/W	R/W	R/W	R/W	R/W	R/W	R/W

Bit 0 ~ Bit 8 (P60 ~ P67) : 8-bit PORT6(0~7) I/O data register

User can use IOC register to define input or output each bit.

#### PAGE1 (LCD data)

7	6	5	4	3	2	1	0
LCDD7	LCDD6	LCDD5	LCDD4	LCDD3	LCDD2	LCDD1	LCDD0
R/W	R/W	R/W	R/W	R/W	R/W	R/W	R/W

Bit 0 ~ Bit 7 (LCDD0 ~ LCDD7) : LCD data buffer for LCD RAM read or write

LCD data vs. COM-SEG		LCD address (LCDA3 ~ LCDA0)
LCDD7 ~ LCDD4	LCDD3 ~ LCDD0	
COM3 ~ COM0	COM3 ~ COM0	
SEG1	SEG0	00H
SEG3	SEG2	01H
SEG5	SEG4	02H
SEG7	SEG6	03H
SEG9	SEG8	04H
SEG11	SEG10	05H
SEG13	SEG12	06H
SEG15	SEG14	07H
SEG17	SEG16	08H
SEG19	SEG18	09H
SEG21	SEG20	0AH
SEG23	SEG22	0BH
SEG25	SEG24	0CH
SEG27	SEG26	0DH
SEG29	SEG28	0EH
SEG31	SEG30	0FH



**R7 (PORT7 I/O data, Data RAM bank)**

**PAGE0 (PORT7 I/O data register)**

7	6	5	4	3	2	1	0
P77	P76	P75	P74	P73	P72	P71	P70
R/W	R/W	R/W	R/W	R/W	R/W	R/W	R/W

Bit 0 ~ Bit 7 (P70 ~ P77) : 8-bit PORT7(0~7) I/O data register

User can use IOC register to define input or output each bit.

**PAGE1 (CTCSS detection output, Data RAM bank selection bits)**

7	6	5	4	3	2	1	0
-	DETO	-	-	-	-	RAM_B1	RAM_B0
	R					R/W-0	R/W-0

Bit 0 ~ Bit1 (RAM\_B0 ~ RAM\_B1) : Data RAM bank selection bits

Each bank has address 0 ~ address 255 which is total 256 (0.25k) bytes RAM size.

Data RAM bank selection : (Total RAM = 1.0K)

RAM_B1	RAM_B0	RAM bank
0	0	Bank0
0	1	Bank1
1	0	Bank2
1	1	Bank3

Bit 2 ~ Bit 5 : (undefined) not allowed to use

Bit 6(DETO) : CTCSS tone detection

The signal passing CTCSS sub audio LPF will be extracted CTCSS tone. Then this tone will go into the ZC(Zero-crossing detector) and output to DETO bit. This bit reflects the CTCSS tone frequency pulse waveform. The user can count the timing to get the CTCSS frequency. Also see IOCE PAGE1 for CTCSS block and switch control.

Bit 7 : (undefined) not allowed to use

**R8 (PORT8 I/O data, Data RAM address)**

**PAGE0 (PORT8 I/O data register)**

7	6	5	4	3	2	1	0
P87	P86	P85	P84	P83	P82	P81	P80
R/W	R/W	R/W	R/W	R/W	R/W	R/W	R/W

Bit 0 ~ Bit 7 (P80 ~ P87) : 8-bit PORT8(0~7) I/O data register

User can use IOC register to define input or output each bit.

**PAGE1 (Data RAM address register)**

7	6	5	4	3	2	1	0
RAM_A7	RAM_A6	RAM_A5	RAM_A4	RAM_A3	RAM_A2	RAM_A1	RAM_A0
R/W-0	R/W-0	R/W-0	R/W-0	R/W-0	R/W-0	R/W-0	R/W-0

Bit 0 ~ Bit 7 (RAM\_A0 ~ RAM\_A7) : data RAM address

The data RAM bank's selection is from R7 PAGE1 bit0 ~ bit 1 (RAM\_B0 ~ RAM\_B1).

**R9 (PORT9 I/O data, Data RAM data buffer)**

**PAGE0 (PORT9 I/O data register)**

7	6	5	4	3	2	1	0
P97	P96	P95	P94	P93	P92	P91	P90
R/W	R/W	R/W	R/W	R/W	R/W	R/W	R/W

Bit 0 ~ Bit 7 (P90 ~ P97) : 8-bit PORT9(0~7) I/O data register

User can use IOC register to define input or output each bit.

PAGE1 (Data RAM data register)

7	6	5	4	3	2	1	0
RAM_D7	RAM_D6	RAM_D5	RAM_D4	RAM_D3	RAM_D2	RAM_D1	RAM_D0
R/W	R/W	R/W	R/W	R/W	R/W	R/W	R/W

Bit 0 ~ Bit 7 (RAM\_D0 ~ RAM\_D7) : Data RAM's data

The address for data RAM is accessed from R8 PAGE1. The data RAM bank is selected by R7 PAGE1 Bit 0 ~ Bit 1 (RAM\_B0 ~ RAM\_B1).

RA (PLL, Main clock selection, Comparator flag, Watchdog timer, DAC input data buffer, LCD option)

PAGE0 (PLL enable bit, Main clock selection bits, Comparator control bits, Watchdog timer enable bit)

7	6	5	4	3	2	1	0
IDLE	PLLEN	CLK2	CLK1	CLK0	CMPFLAG	CMPREF	WDTEN
R/W-0	R/W-0	R/W-0	R/W-1	R/W-1	R	R/W-0	R/W-0

Bit 0(WDTEN) : Watch dog control bit

0/1 → disable/enable

User can use WDTC instruction to clear watch dog counter. The counter's clock source is 32768/2 Hz. If the prescaler assigns to TCC. Watch dog will time out by  $(1/32768) * 2 * 256 = 15.616\text{mS}$ . If the prescaler assigns to WDT, the time of time out will be more times depending on the ratio of prescaler.

Bit 1(CMPREF) : Comparator's reference voltage source selection bit

0 → Comparator's reference voltage is driven from internal bias resistor string. This reference voltage level can be set by RD PAGE0 bit 0 ~ bit 5 (CMP\_B0 ~ CMP\_B5).

1 → Comparator's reference voltage is driven from external bias. This reference voltage input is CMP3/P65 pin. Also IOC6 PAGE1 bit 2(CMP63/P63) should be set to "1".

Bit 2(CMPFLAG) : Output of the comparator

0 → Input voltage < reference voltage

1 → input voltage > reference voltage

Bit 3 ~ Bit 5 (CLK0 ~ CLK2) : MAIN clock selection bits

User can choose different frequency of main clock by CLK1 and CLK2. All the clock selection is list below.

PLLEN	CLK2	CLK1	CLK0	Sub clock	MAIN clock	CPU clock
1	0	0	0	32.768kHz	447.829kHz	447.829kHz (Normal mode)
1	0	0	1	32.768kHz	895.658kHz	895.658kHz (Normal mode)
1	0	1	0	32.768kHz	1.791MHz	1.791MHz (Normal mode)
1	0	1	1	32.768kHz	3.582MHz	3.582MHz (Normal mode)
1	1	0	0	32.768kHz	7.165MHz	7.165MHz (Normal mode)
1	1	0	1	32.768kHz	10.747MHz	10.747MHz (Normal mode)
1	1	1	0	32.768kHz	14.331MHz	14.331MHz (Normal mode)
1	1	1	1	32.768kHz	17.913MHz	17.913MHz (Normal mode)
0	don't care		don't care	32.768kHz	don't care	32.768kHz (Green mode)

Bit 6(PLLEN) : PLL's power control bit which is CPU mode control register

0/1 → disable PLL/enable PLL

If enable PLL, CPU will operate at normal mode (high frequency). Otherwise, it will run at green mode (low frequency, 32768 Hz).

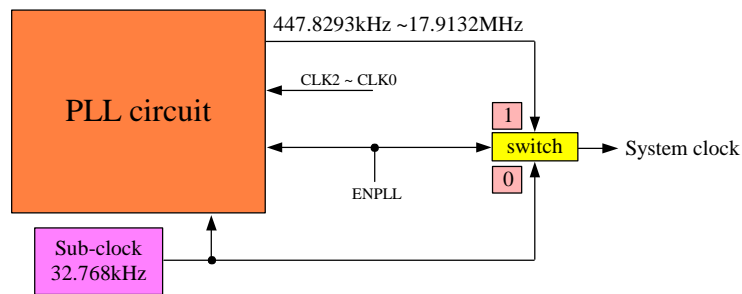

Fig.4 The relation between 32.768kHz and PLL

Bit 7(IDLE) : Sleep mode or IDLE mode control after using "SLEP" instruction.

0/1 → SLEEP mode/IDLE mode.

This bit will decide SLEP instruction which mode to go.

The status after wake-up and the wake-up sources list as the table below.

Wakeup signal	SLEEP mode	IDLE mode
	RA(7,6)=(0,0) + SLEP	RA(7,6)=(1,0) + SLEP
TCC time out IOCF bit0=1	No function	(1) Wake-up (2) Jump to SLEP next instruction
COUNTER1 time out IOCF bit1=1	No function	(1) Wake-up (2) Jump to SLEP next instruction
COUNTER2 time out IOCF bit2=2	No function	(1) Wake-up (2) Jump to SLEP next instruction
WDT time out	Reset and jump to address 0	(1) Wake-up (2) Next instruction
PORT8(0~3) RE PAGE0 bit3 or bit4 or bit5 or bit6 = 1	Reset and Jump to address 0	(1) Wake-up (2) Jump to SLEP next instruction
PORT7(0~3) IOCF bit3 or bit4 or bit5 or bit7=1	Reset and Jump to address 0	(1) Wake-up (2) Jump to SLEP next instruction

<Note> PORT70 's wakeup function is controlled by IOCF bit 3. It's falling edge or rising edge trigger (controlled by CONT register bit7).

PORT7(1~3) 's wakeup functions are controlled by IOCF bit (4,5,7). They are falling edge trigger.

PORT80~PORT83's wakeup function are controlled by RE PAGE0 bit 0 ~ bit 3. They are falling edge trigger.



**PAGE1 (DAC input data register)**

7	6	5	4	3	2	1	0
DA7	DA6	DA5	DA4	DA3	DA2	DA1	DA0
R/W-1	R/W-1	R/W-1	R/W-1	R/W-1	R/W-1	R/W-1	R/W-1

Bit 0 ~ Bit 7 (DA0 to DA7) : DA converter data buffer

**PAGE2 (LCD waveform option, Multiplication control)**

7	6	5	4	3	2	1	0
LCDOPT	-	-	-	-	-	-	-
R/W-0							

Bit 0 ~ Bit 6 : (undefined) not allowed to use

Bit 7 (LCDOPT) : LCD output waveform option

0 → default LCD waveform for Type0 LCD waveform

1 → switch over LCD bias V1 and V2 for segment for Type1 LCD waveform

(Please set this bit to "1" to get better display performance while LCD driver is used)

**RB (PORTB I/O data, ADC output data buffer)**

**PAGE0 (PORT9 I/O data register)**

7	6	5	4	3	2	1	0
PB7	PB6	PB5	PB4	PB3	PB2	PB1	PB0
R/W	R/W	R/W	R/W	R/W	R/W	R/W	R/W

Bit 0 ~ Bit 7 (PB0 ~ PB7) : 8-bit PORTB(0~7) I/O data register

User can use IOC register to define input or output each bit.

**RC (PORTC I/O data, Counter1 data)**

**PAGE0 (PORT9 I/O data register)**

7	6	5	4	3	2	1	0
PC7	PC6	PC5	PC4	PC3	PC2	PC1	PC0
R/W	R/W	R/W	R/W	R/W	R/W	R/W	R/W

Bit 0 ~ Bit 7 (PC0 ~ PC7) : 8-bit PORTC(0~7) I/O data register

User can use IOC register to define input or output each bit.

**PAGE1 (Counter1 data register)**

Bit7	Bit6	Bit5	Bit4	Bit3	Bit2	Bit1	Bit0
CN17	CN16	CN15	CN14	CN13	CN12	CN11	CN10
R/W-0	R/W-0	R/W-0	R/W-0	R/W-0	R/W-0	R/W-0	R/W-0

Bit 0 ~ Bit 7 (CN10 ~ CN17) : Counter1's buffer that user can read and write.

Counter1 is a 8-bit up-counter with 8-bit prescaler that user can use RC PAGE1 to preset and read the counter.(write → preset) After a interruption , it will reload the preset value.

Example for writing :

MOV 0x0C, A ; write the data at accumulator to counter1 (preset)

Example for reading :

MOV A, 0x0C ; read the data at counter1 to accumulator

**RD (LCD control, Counter2 data, PWM1,2 duty latch, Multiplication result)**

**PAGE0 (LCD driver control bits)**

7	6	5	4	3	2	1	0
DETOED	-	-	-	-	LCD_C1	LCD_C0	LCD_M
R/W-0					R/W-0	R/W-0	R/W-0

Bit 0 (LCD\_M) : LCD operation method including duty and frame frequency

Bit 1 ~ Bit 2 (LCD\_C0 ~ LCD\_C1) : LCD display control

LCD_C1	LCD_C0	LCD_M	LCD Display Control	Duty	Bias
0	0	0	change duty	1/4	1/3
		1	Disable(turn off LCD)	1/2	1/3
0	1	:	Blanking	:	:
1	1	:	LCD display enable	:	:

Ps. To change the display duty must set the "LCD\_C1 ,LCD\_C0" to "00".

The controller can drive LCD directly. The LCD block is made up of common driver, segment driver, display LCD RAM, common output pins, segment output pins and LCD operating power supply. The basic structure contains a timing control. This timing control uses the basic frequency 32.768KHz to generate the proper timing for different duty and display access.

RD PAGE0 Bit 0 ~ Bit 2 are LCD control bits for LCD driver. These LCD control bits determine the duty, the number of common and the frame frequency. The LCD display (disable, enable, blanking) is controlled by Bit 1 and Bit 2. The driving duty is decided by Bit 0. The display data is stored in LCD RAM which address and data access controlled by registers R5 PAGE1 and R6 PAGE1.

User can regulate the contrast of LCD display by IOC5 PAGE0 Bit 0 ~ Bit 3 (BIAS0 ~ BIAS3). Up to 16 levels contrast is convenient for better display.

Bit 3 ~ Bit 6 : *(undefined) not allowed to use*

Bit 7 (DETOED) : the interrupt triggering edge control for CTCSS tone detection output

0/1 → falling edge/falling and rising

PAGE1 (Counter2 data register)

Bit7	Bit6	Bit5	Bit4	Bit3	Bit2	Bit1	Bit0
CN27	CN26	CN25	CN24	CN23	CN22	CN21	CN20
R/W-0	R/W-0	R/W-0	R/W-0	R/W-0	R/W-0	R/W-0	R/W-0

Bit 0 ~ Bit 7 (CN20 ~ CN27) : Counter2's buffer that user can read and write.

Counter2 is a 8-bit up-counter with 8-bit prescaler that user can use RD PAGE1 to preset and read the counter.(write → preset) After a interruption, it will reload the preset value.

Example for writing :

MOV 0x0D, A ; write the data at accumulator to counter2 (preset)

Example for reading :

MOV A, 0x0D ; read the data at counter2 to accumulator

RE (Interrupt flag, Wake-up control, DAC tone output frequency selection, PWM2 duty latch, Multiplication result)

PAGE0 (Interrupt flag, Wake-up control bits)

7	6	5	4	3	2	1	0
-	-	-	-	/WUP83	/WUP82	/WUP81	/WUP80
				R/W-0	R/W-0	R/W-0	R/W-0

Bit 0 (/WUP80) : PORT80 wake-up control, 0/1 → disable/enable P80 pin wake-up function

Bit 1 (/WUP81) : PORT81 wake-up control, 0/1 → disable/enable P81 pin wake-up function

Bit 2 (/WUP82) : PORT82 wake-up control, 0/1 → disable/enable P82 pin wake-up function

Bit 3 (/WUP83) : PORT83 wake-up control, 0/1 → disable/enable P83 pin wake-up function

Bit 4 ~ Bit 7 : *(undefined) not allowed to use*

Set when a selected period is reached, reset by software.

PAGE1 (Programmable D/A tone selection register)

7	6	5	4	3	2	1	0
DAT7	DAT6	DAT5	DAT4	DAT3	DAT2	DAT1	DAT0
R/W-1	R/W-1	R/W-1	R/W-1	R/W-1	R/W-1	R/W-1	R/W-1

Bit 0 ~ Bit 7 (DAT0 ~ DAT7) : D/A tone output frequency selection

The programmable D/A tone output frequency =  $447829\text{Hz} / M_i / 32$ , where  $M_i = \text{DAT7} \sim \text{DAT0} = 1 \sim 255$   
When  $M_i = \text{DAT7} \sim \text{DAT0} = 0$  or  $\text{DAT/DAD}(\text{IOCA PAGE1 Bit 7}) = 0$ , the D/A tone output generation circuit will be disabled. It is specially used for CTCSS tone generation. Also refer to DAC for details.

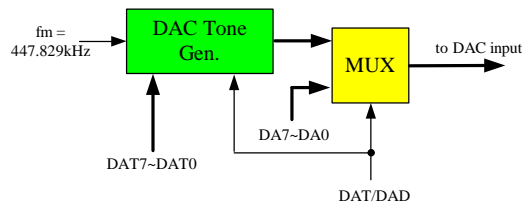

Fig.5 Programmable DAC tone generation

For example : CTCSS tone generation table

Channel	DAT7~DAT0	D/A tone generation	CTCSS tone	Mi (decimal)	Act. Freq.
-	00000000	Disable	-	-	-
1	11010001	Enable	67.0	209	66.960
2	11001010		69.3	202	69.280
3	11000011		71.9	195	71.767
4	10111100		74.4	188	74.440
5	10110110		77.0	182	76.894
6	10110000		79.7	176	79.515
7	10101010		82.5	170	82.322
8	10100100		85.4	164	85.333
9	10011110		88.5	158	88.574
10	10011001		91.5	153	91.468
11	10010100		94.8	148	94.558
12	10010000		97.4	144	97.185
13	10001100		100.0	140	99.962
14	10000111		103.5	135	103.664
15	10000011		107.2	131	106.829
16	01111110		110.9	126	111.069
17	01111010		114.8	122	114.710
18	01110110		118.8	118	118.599
19	01110010		123.0	114	122.760
20	01101110		127.3	110	127.224
21	01101010		131.8	106	132.025
22	01100111		136.5	103	135.870
23	01100011		141.3	99	141.360
24	01100000		146.2	96	145.778
25	01011100		151.4	92	152.116
26	01011001		156.7	89	157.243
27	01011000		159.8	88	159.030
28	01010110		162.2	86	162.729
29	01010011		167.9	83	168.610





30	01010001	173.8	81	172.773
31	01001110	179.9	78	179.419
32	01001100	183.5	76	184.140
33	01001011	186.2	75	186.595
34	01001010	189.9	74	189.117
35	01001001	192.8	73	191.708
36	01000111	196.6	71	197.108
37	01000110	199.5	70	199.924
38	01000101	203.5	69	202.821
39	01000100	206.5	68	205.804
40	01000010	210.7	66	212.040
41	01000000	218.1	64	218.667
42	00111110	225.7	62	225.720
43	00111101	229.1	61	229.421
44	00111100	233.6	60	233.244
45	00111010	241.8	58	241.287
46	00111000	250.3	56	249.905
47	00110111	254.1	55	254.448

### RF (Interrupt status)

(Interrupt status register)

7	6	5	4	3	2	1	0
INT3	DETO	INT2	INT1	INT0	CNT2	CNT1	TCIF
R/W-0	R/W-0	R/W-0	R/W-0	R/W-0	R/W-0	R/W-0	R/W-0

"1" means interrupt request, "0" means non-interrupt

Bit 0(TCIF) : TCC timer overflow interrupt flag

Set when TCC timer overflows.

Bit 1(CNT1) : counter1 timer overflow interrupt flag

Set when counter1 timer overflows.

Bit 2(CNT2) : counter2 timer overflow interrupt flag

Set when counter2 timer overflows.

Bit 3(INT0) : external INT0 pin interrupt flag

If PORT70 has a falling edge/rising edge (controlled by CONT register) trigger signal, CPU will set this bit.

Bit 4(INT1) : external INT1 pin interrupt flag

If PORT71 has a falling edge trigger signal, CPU will set this bit.

Bit 5(INT2) : external INT2 pin interrupt flag

If PORT72 has a falling edge trigger signal, CPU will set this bit.

Bit 6(DETO) : CTCSS tone detection interrupt flag

If CTCSS detection output signal(R7 PAGE1 bit 6) has an edge signal (falling edge, falling and rising edge), CPU will set this bit.

Bit 7(INT3) : external INT3 pin interrupt flag

If PORT73 has a falling edge trigger signal, CPU will set this bit.

<Note> IOCF is the interrupt mask register. User can read and clear.

Trigger edge as the table

Signal	Trigger
TCC	Time out
COUNTER1	Time out
COUNTER2	Time out
INT0	Falling Rising edge
INT1	Falling edge
INT2	Falling edge
DETO	Falling edge Falling and rising edge

#### R10~R3F (General Purpose Register)

R10~R3F (Banks 0 ~ 3) : all are general purpose registers.

### VII.3 Special Purpose Registers

#### A (Accumulator)

Internal data transfer, or instruction operand holding  
It's not an addressable register.

#### CONT (Control Register)

7	6	5	4	3	2	1	0
P70EG	INT	TS	RETBK	PAB	PSR2	PSR1	PSR0

Bit 0 ~ Bit 2 (PSR0 ~ PSR2) : TCC/WDT prescaler bits

PSR2	PSR1	PSR0	TCC rate	WDT rate
0	0	0	1:2	1:1
0	0	1	1:4	1:2
0	1	0	1:8	1:4
0	1	1	1:16	1:8
1	0	0	1:32	1:16
1	0	1	1:64	1:32
1	1	0	1:128	1:64
1	1	1	1:256	1:128

Bit 3(PAB) : Prescaler assignment bit

0/1 → TCC/WDT

Bit 4(RETBK) : Return value backup control for interrupt routine

0 → disable/enable

When this bit is set to 1, the CPU will store ACC,R3 status and R5 PAGE automatically after an interrupt is triggered. And it will be restored after instruction RETI. When this bit is set to 0, the user need to store ACC, R3 and R5 PAGE in user program.

Bit 5(TS) : TCC signal source

0 → internal instruction cycle clock

1 → 16.384kHz

Bit 6 (INT) : INT enable flag

0 → interrupt masked by DISI or hardware interrupt

1 → interrupt enabled by ENI/RETI instructions

Bit 7(P70EG) : interrupt edge type of P70

0 → P70 's interruption source is a rising edge signal.

1 → P70 's interruption source is a falling edge signal.

CONT register is readable (CONTR) and writable (CONTW).

TCC and WDT :

There is an 8-bit counter available as prescaler for the TCC or WDT. The prescaler is available for the TCC only or WDT only at the same time.

An 8 bit counter is available for TCC or WDT determined by the status of the bit 3 (PAB) of the CONT register.

See the prescaler ratio in CONT register.

Fig.17 depicts the circuit diagram of TCC/WDT.

Both TCC and prescaler will be cleared by instructions which write to TCC each time.

The prescaler will be cleared by the WDTC and SLEP instructions, when assigned to WDT mode.

The prescaler will not be cleared by SLEP instructions, when assigned to TCC mode.



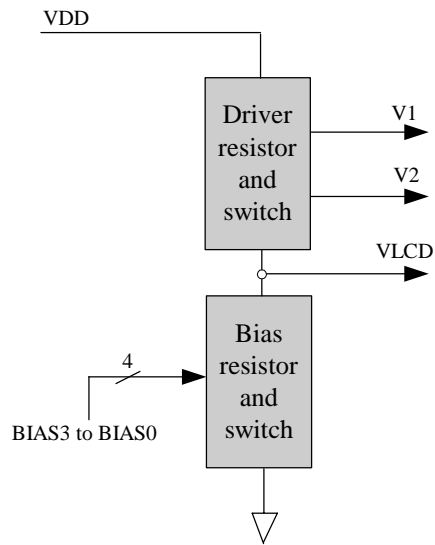

Fig.7 LCD driver bias circuit

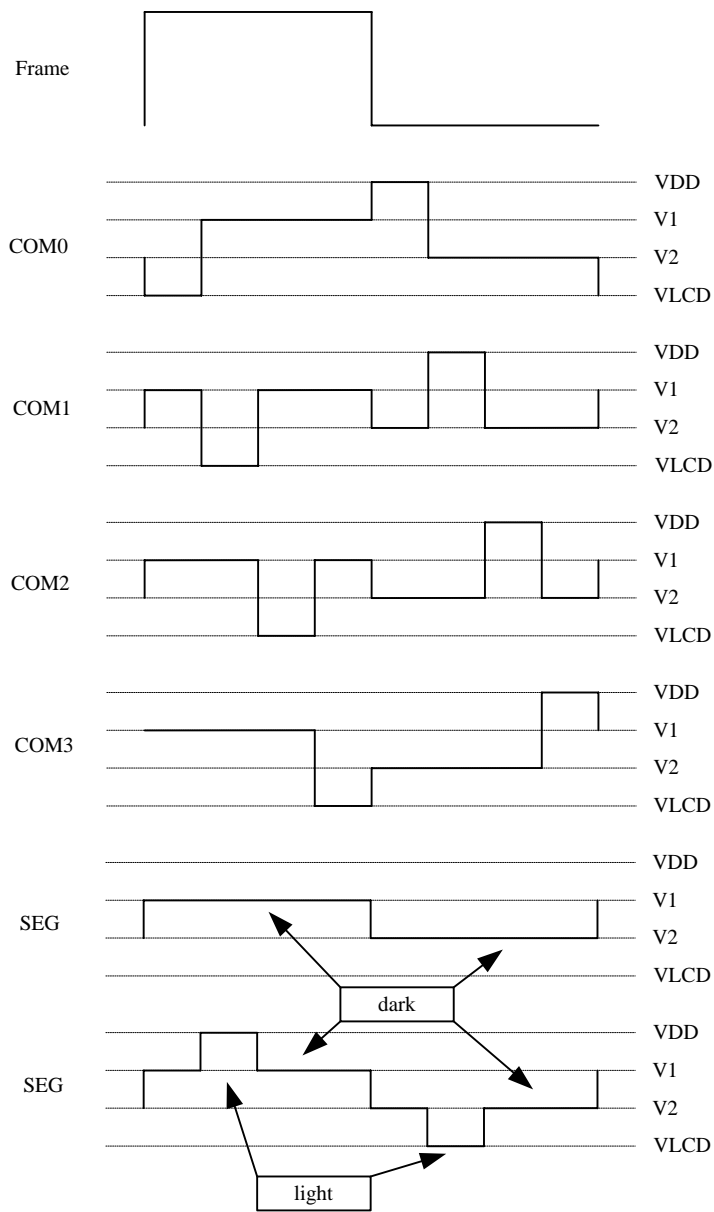

Fig.8a Type0's LCD waveform for 1/3 bias, 1/4 duty  
(Type0 or type1 is controlled by RA PAGE2 bit7)

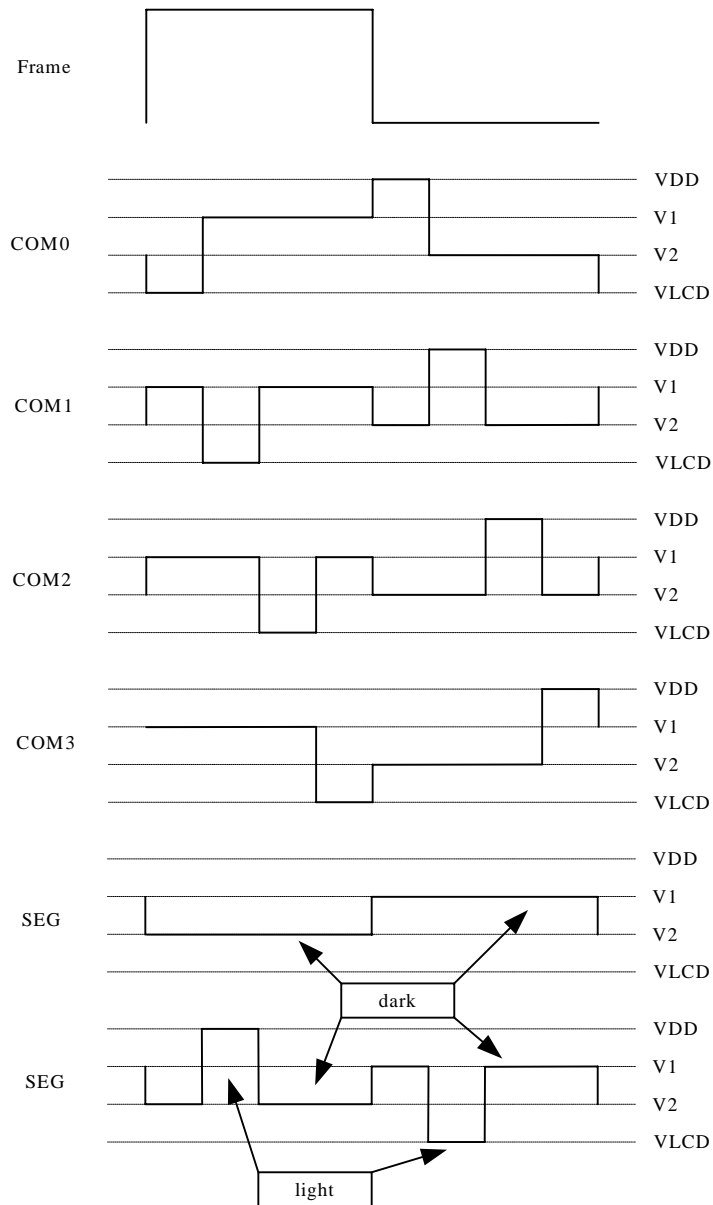

Fig.8b Type1's LCD waveform for 1/3 bias, 1/4 duty  
(Type0 or type1 is controlled by RA PAGE2 bit7)

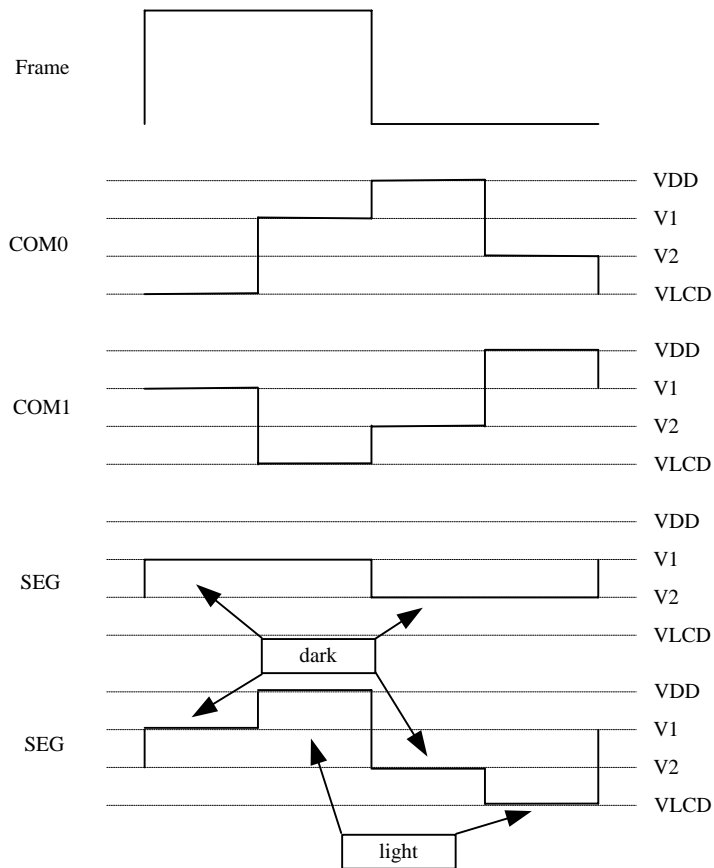

Fig.9a Type0's LCD waveform for 1/3 bias, 1/2 duty  
(Type0 or type1 is controlled by RA PAGE2 bit7)



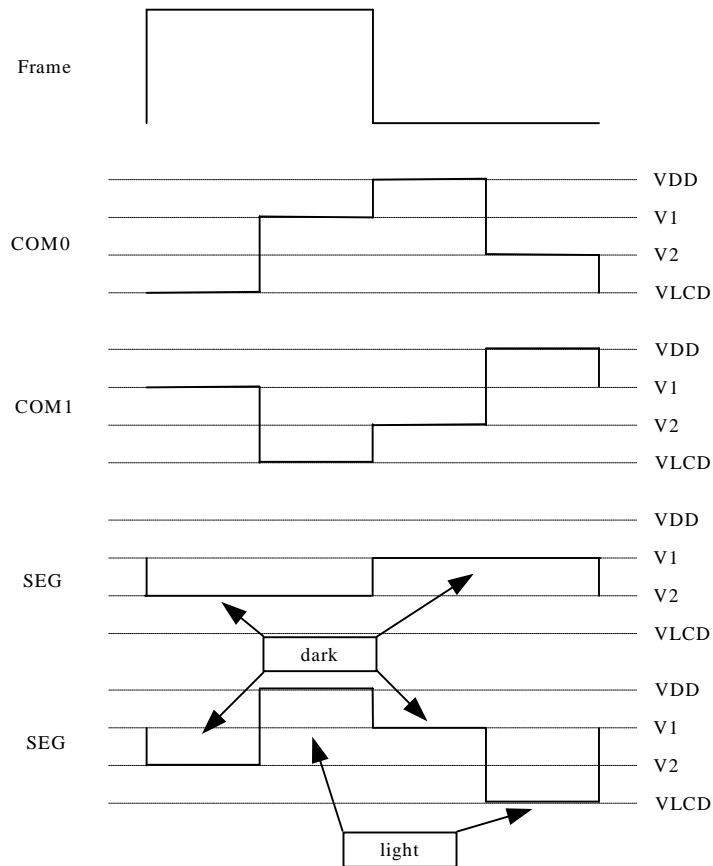

Fig.9b Type1's LCD waveform for 1/3 bias, 1/2 duty  
(Type0 or type1 is controlled by RA PAGE2 bit7)

PAGE1 (Comparator control register)

7	6	5	4	3	2	1	0
CMPEN	CMPS1	CMPS0	CMP_B4	CMP_B3	CMP_B2	CMP_B1	CMP_B0
R/W-0	R/W-0	R/W-0	R/W-0	R/W-0	R/W-0	R/W-0	R/W-0

If user define CMP1/P63 pin, CMP2/P64 pin or CMP3/P65 pin (by CMPIN1, CMPIN2, CMPIN3 at IOCE page1) as CMP1, CMP2 pin or CMP3 pin (comparator's input pins), user can use this register to control comparator's function.

Bit 0 ~ Bit 4 (CMP\_B0 ~ CMP\_B4) : Reference voltage selection of internal bias resistor string

Voltage =  $VR \times (n + 0.5) / 32$ ,  $n=0$  to 31. Set IOCA page1 bit 4 (VRSEL) to select  $VR = VDD$  or 2.5V

Bit 5 ~ Bit 6 (CMPS0 ~ CMPS1) : Comparator's channel selection bits from CMP1 to CMP3

Bit 7(CMPEN) : Enable bit of the comparator circuit

0/1 → disable/enable the comparator circuit

CMPS1	CMPS0	Input
0	0	CMP1
0	1	CMP2
1	0	CMP3
1	1	Reserved

The relation between these registers is shown as follows in Fig.10.  
Ps. VRSEL bit is in IOCA PAGE1 bit 4.

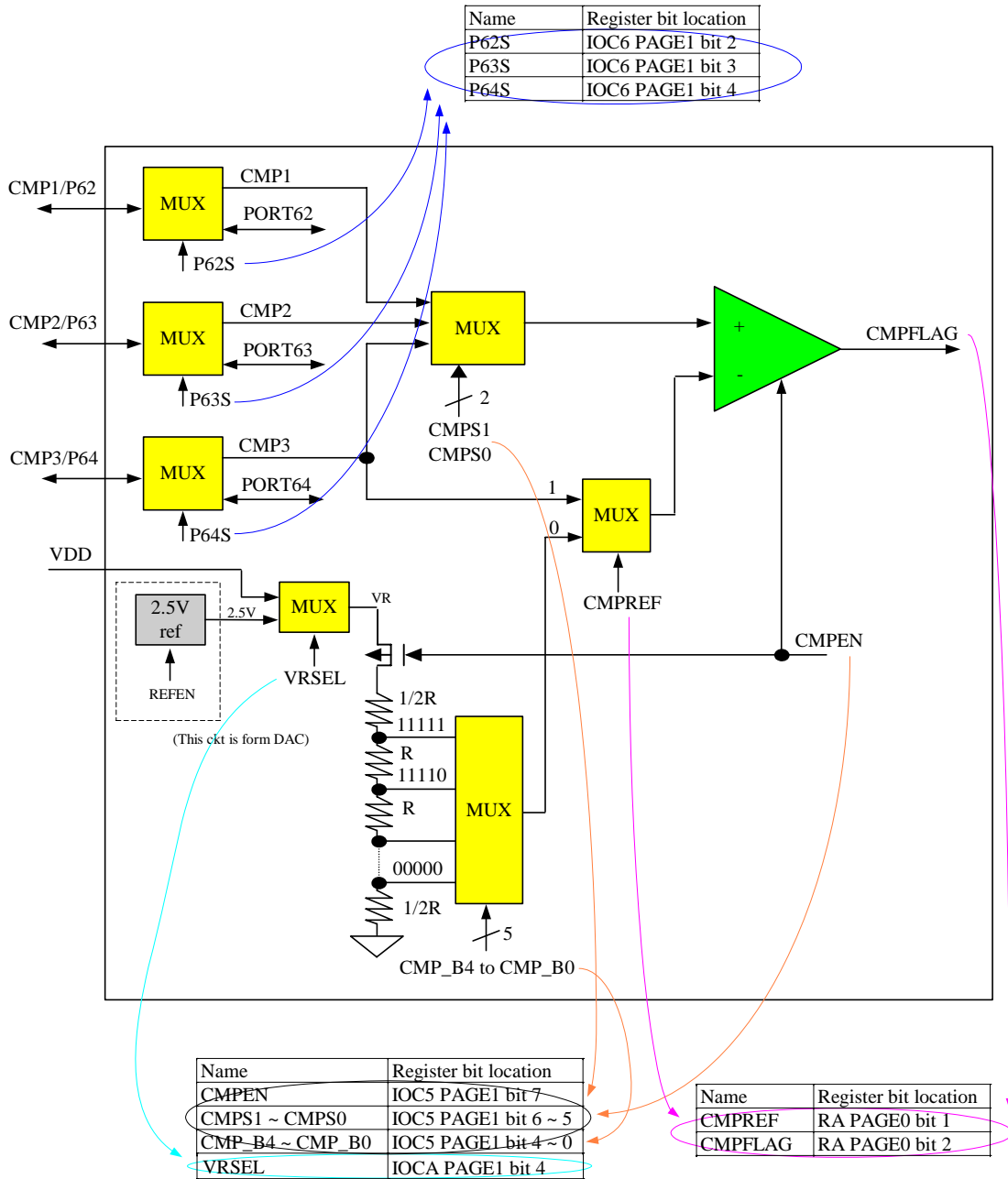

Fig.10 The comparator circuit

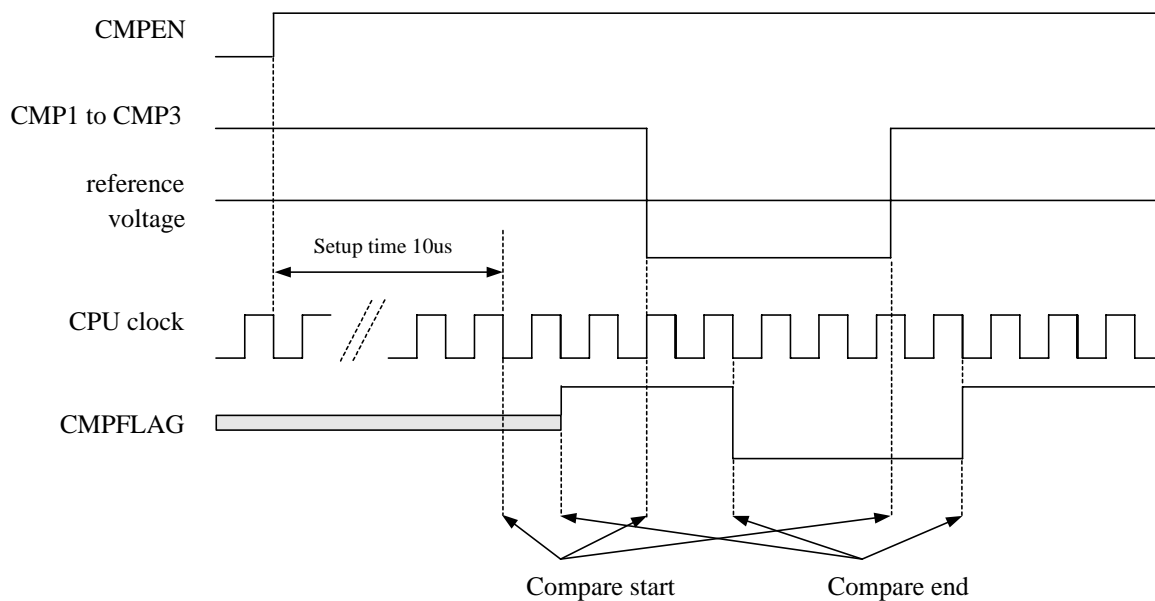

Fig.11 The comparator timing

**IOC6 (PORT6 I/O control, P6\* pins switch control)**

**PAGE0 (PORT6 I/O control register)**

7	6	5	4	3	2	1	0
IOC67	IOC66	IOC65	IOC64	IOC63	IOC62	IOC61	IOC60
R/W-1	R/W-1	R/W-1	R/W-1	R/W-1	R/W-1	R/W-1	R/W-1

Bit 0 ~ Bit 7 (IOC60 ~ IOC67) : PORT6(0~7) I/O direction control register

0 → put the relative I/O pin as output

1 → put the relative I/O pin into high impedance

**PAGE1 (P6\* pins switch control register)**

7	6	5	4	3	2	1	0
AMUTE	P66S	P65S	P64S	P63S	P62S	-	-
R/W-0	R/W-0	R/W-0	R/W-0	R/W-0	R/W-0	R/W-0	R/W-0

Bit 0 ~ Bit 1 : (remain these values to "0" unchanged if PORT60,61 are used)

Bit 2(P62S) : Select channel 2 input pin of comparator or I/O PORT63 pin

0 → P62 (I/O PORT62) pin is selected

1 → CMP1 (Channel 1 input of comparator) pin is selected

Bit 3(P63S) : Select channel 2 input pin of comparator or I/O PORT63 pin

0 → P63 (I/O PORT63) pin is selected

1 → CMP2 (Channel 2 input of comparator) pin is selected

Bit 4(P64S) : Select channel 3 input pin of comparator or I/O PORT64 pin

0 → P64 (I/O PORT64) pin is selected

1 → CMP3 (Channel 3 input of comparator) pin is selected

Bit 5(P65S) : Select receiving audio output pin of CTCSS or I/O PORT65 pin

0 → P65 (I/O PORT65) pin is selected

1 → AURX (Receiving audio output pin of CTCSS) pin is selected

Bit 6(P66S) : Select modulation transmitting output pin of CTCSS or I/O PORT66 pin  
 0 → P66 (I/O PORT66) pin is selected  
 1 → MTX (Modulation transmitting output of CTCSS) pin is selected  
 Bit 7(AMUTE) : Audio mute for MIC AMP of CTCSS block  
 0 → Voice transmitting path from MIC AMP output  
 1 → Audio mute from MIC AMP output  
 Refer to Fig.19 CTCSS block for details.

### IOC7 (PORT7 I/O control, PORT7 pull high control)

#### PAGE0 (PORT7 I/O control register)

7	6	5	4	3	2	1	0
IOC77	IOC76	IOC75	IOC74	IOC73	IOC72	IOC71	IOC70
R/W-1	R/W-1	R/W-1	R/W-1	R/W-1	R/W-1	R/W-1	R/W-1

Bit 0 ~ Bit 7 (IOC70 ~ IOC77) : PORT7(0~7) I/O direction control register  
 0 → put the relative I/O pin as output  
 1 → put the relative I/O pin into high impedance

#### PAGE1 (PORT7 pull high control register)

7	6	5	4	3	2	1	0
PH77	PH76	PH75	PH74	PH73	PH72	PH71	PH70
R/W-0	R/W-0	R/W-0	R/W-0	R/W-0	R/W-0	R/W-0	R/W-0

Bit 0 ~ Bit 7 (PH70 ~ PH77) : PORT7 bit0~bit7 pull high control register  
 0 → disable pull high function.  
 1 → enable pull high function

### IOC8 (PORT8 I/O control, PORT8 pull high control)

#### PAGE0 (PORT8 I/O control register)

7	6	5	4	3	2	1	0
IOC87	IOC86	IOC85	IOC84	IOC83	IOC82	IOC81	IOC80
R/W-1	R/W-1	R/W-1	R/W-1	R/W-1	R/W-1	R/W-1	R/W-1

Bit 0 ~ Bit 7 (IOC80 ~ IOC87) : PORT8(0~7) I/O direction control register  
 0 → put the relative I/O pin as output  
 1 → put the relative I/O pin into high impedance

#### PAGE1 (PORT8 pull high control register)

7	6	5	4	3	2	1	0
PH87	PH86	PH85	PH84	PH83	PH82	PH81	PH80
R/W-0	R/W-0	R/W-0	R/W-0	R/W-0	R/W-0	R/W-0	R/W-0

Bit 0 ~ Bit 7 (PH80 ~ PH87) : PORT8 bit0~bit7 pull high control register  
 0 → disable pull high function.  
 1 → enable pull high function

### IOC9 (PORT9 I/O control, PORT9 switches)

#### PAGE0 (PORT9 I/O control register)

7	6	5	4	3	2	1	0
IOC97	IOC96	IOC95	IOC94	IOC93	IOC92	IOC91	IOC90
R/W-1	R/W-1	R/W-1	R/W-1	R/W-1	R/W-1	R/W-1	R/W-1



Bit 0 ~ Bit 7 (IOC90 ~ IOC97) : PORT9(0~7) I/O direction control register

0 → put the relative I/O pin as output

1 → put the relative I/O pin into high impedance

**PAGE1 (PORT9 switches)**

7	6	5	4	3	2	1	0
P97S	P96S	P95S	P94S	P93S	P92S	P91S	P90S
R/W-0	R/W-0	R/W-0	R/W-0	R/W-0	R/W-0	R/W-0	R/W-0

Bit 0(P90S) : Switch I/O PORT90 or LCD segment signal

0 → (P90 pin is selected) : normal PORT90

1 → (SEG20 pin) : SEGMENT output

Bit 1(P91S) : Switch I/O PORT91 or LCD segment signal

0 → (P91 pin is selected) : normal PORT91

1 → (SEG19 pin) : SEGMENT output

Bit 2(P92S) : Switch I/O PORT92 or LCD segment signal

0 → (P92 pin is selected) : normal PORT92

1 → (SEG18 pin) : SEGMENT output

Bit 3(P93S) : Switch I/O PORT93 or LCD segment signal

0 → (P93 pin is selected) : normal PORT93

1 → (SEG17 pin) : SEGMENT output

Bit 4(P94S) : Switch I/O PORT94 or LCD segment signal

0 → (P94 pin is selected) : normal PORT94

1 → (SEG16 pin) : SEGMENT output

Bit 5(P95S) : Switch I/O PORT95 or LCD segment signal

0 → (P95 pin is selected) : normal PORT95

1 → (SEG15 pin) : SEGMENT output

Bit 6(P96S) : Switch I/O PORT96 or LCD segment signal

0 → (P96 pin is selected) : normal PORT96

1 → (SEG14 pin) : SEGMENT output

Bit 7(P97S) : Switch I/O PORT97 or LCD segment signal

0 → (P97 pin is selected) : normal PORT97

1 → (SEG13 pin) : SEGMENT output

**IOCA (TONE2 control, Control bits for DAC, DAC tone, Reference)**

**PAGE0 (TONE2 control register)**

7	6	5	4	3	2	1	0
T27	T26	T25	T24	T23	T22	T21	T20
R/W-0	R/W-0	R/W-0	R/W-0	R/W-0	R/W-0	R/W-0	R/W-0

Bit 0 ~ Bit 7(T20 ~ T27) : Tone generator 2 's frequency divider and power control

Please Run in Normal mode .

Clock source = 111957Hz

T27~T20 = '11111111' => Tone generator2 will has 438Hz SIN wave output.

:

T27~T20 = '0000010' => Tone generator2 will has 55921Hz SIN wave output.

T27~T20 = '00000001' => DC bias voltage output

T27~T20 = '00000000' => Power off

Built-in tone generators can generate dialing tone signals for telephone of dialing tone type or just a single tone. In DTMF application, there are two kinds of tone. One is the group of row frequency (TONE1), the

other is the group of column frequency (TONE2), each group has 4 kinds of frequency, user can get 16 kinds of DTMF frequency totally. Tone generator contains a row frequency sine wave generator for generating the DTMF signal which selected by IOCD PAGE0, IOCE PAGE0 and a column frequency sine wave generator for generating the DTMF signal which selected by IOCA PAGE0. This block can generate single tone by filling one of these two register.

If all the values are low, the power of tone generators will turn off .

		TONE2 (IOCA PAGE0) High group freq.			
		1203.8 (0X5D)	1332.8(0X54)	1473.1(0X4C)	1646.4(0X44)
TONE1(IOCD, IOCE PAGE0) Low group freq.	699.7Hz(0x0A0)	1	2	3	A
	772.1Hz(0x091)	4	5	6	B
	854.6Hz(0x083)	7	8	9	C
	940.8Hz(0x077)	*	0	#	D

PAGE1 (Control bits for DAC, DAC tone, Reference)

7	6	5	4	3	2	1	0
DAT/DAD	VREF	DATEN	VRSEL	DAST/P67	-	-	-
R/W-0	R/W-0	R/W-0	R/W-0	R/W-0			

Bit 0 ~ Bit 2 : (undefined) not allowed to use

Bit 3(DAST/P67) : DAC enable control or P67 switch

0 → switch DAO/P67 pin as normal I/O P67

1 → enable DAC, enable DAC output buffer B1 and DAC output to DAO/P67 pin

When this bit is set by software, the DA converter will start converting and output to DAO/P67 pin. If user clean this bit, DA converter will stop and DAO/P67 pin will be become normal I/O P67.

Also refer to bit 5(DATEN) for DAC power control.

Bit 4(VRSEL) : Reference voltage selection bit for Comparator circuit

0/1 → VDD/2.5V from DAC

Also see Fig.16 in the next page.

Bit 5(DATEN) : DAC enable control

0/1 → disable/enable DAC and its tone output buffer B2

When this bit is set by software, the DA converter will start converting and output to internal CTCSS VTX3 end. If user clean this bit, DA converter will stop and DAO tone output buffer B2 is disabled.

Also refer to bit 3(DAST/P67) for DAC power control.

Bit 6(VREF) : Reference voltage selection bit for DA converter circuit

DAC reference setting is shown as following. Also see Fig.16 and Fig.17 in the next page.

ASW3	VREF	DATEN	DAST/P67	Function
1	x	1	x	select 2.5V ref, enable 2.5V ref, enable DAC,
0	1	1	x	enable buffer B2, buffer B2 output to CTCSS LPF
0	0	1	x	select VDD, disable 2.5V, enable DAC, enable buffer B2
x	1	0	1	select 2.5V ref, enable 2.5V ref, enable DAC, enable buffer B1, buffer B1 output to DAO/P67 pin
x	0	0	1	select VDD, disable 2.5V, enable DAC, enable buffer B1, buffer B1 output to DAO/P67 pin

Ps. IOCE PAGE1 bit 2 (ASW3), IOCA PAGE1 bit 6 (VREF), IOCA PAGE1 bit 5 (DATEN),IOCA PAGE1 bit 3 (DAST/P67)

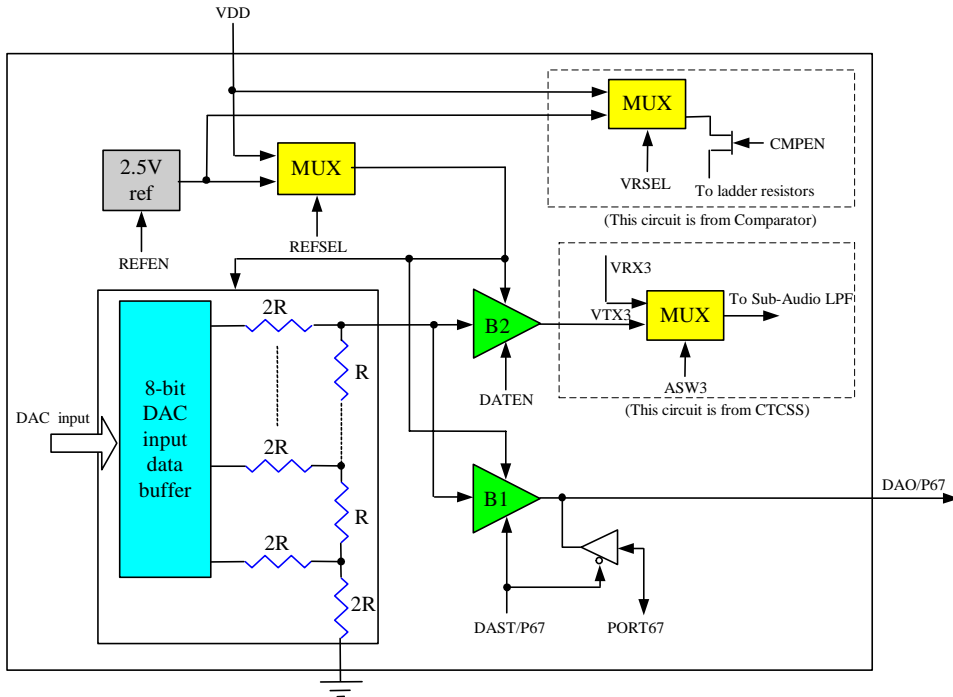

Fig.12 D/A converter (DAC)

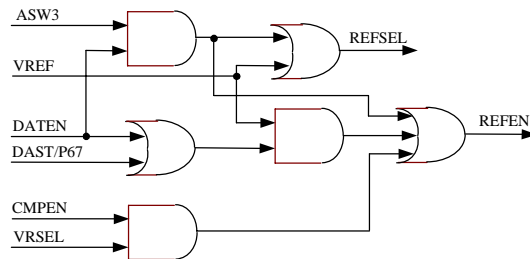

Fig.13 DAC reference voltage control logic

- Bit 7 (DAT/DAD) : Programmable D/A tone generation or D/A input data enable control  
 0 → Enable D/A input data and disable D/A tone generation (also stop to D/A tone generation)  
 1 → Enable Programmable D/A tone generation and disable D/A input data

**IOCB (PORTB I/O control)**

**PAGE0 (PORTB I/O control register)**

7	6	5	4	3	2	1	0
IOCB7	IOCB6	IOCB5	IOCB4	IOCB3	IOCB2	IOCB1	IOCB0
R/W-1	R/W-1	R/W-1	R/W-1	R/W-1	R/W-1	R/W-1	R/W-1

Bit 0 ~ Bit 7 (IOCB0 ~ IOCB7) : PORTB(0~7) I/O direction control register

- 0 → put the relative I/O pin as output  
 1 → put the relative I/O pin into high impedance

**IOCC (PORTC I/O control, ADC control)**
**PAGE0 (PORTC I/O control register)**

7	6	5	4	3	2	1	0
IOCC7	IOCC6	IOCC5	IOCC4	IOCC3	IOCC2	IOCC1	IOCC0
R/W-1	R/W-1	R/W-1	R/W-1	R/W-1	R/W-1	R/W-1	R/W-1

Bit 0 ~ Bit 7 (IOCC0 ~ IOCC7) : PORTC(0~7) I/O direction control register

0 → put the relative I/O pin as output

1 → put the relative I/O pin into high impedance

**PAGE1 (PORT switch)**

7	6	5	4	3	2	1	0
PC7S	PC6S	PC5S	PBSH	PBSL	P5SH	-	-
R/W-0	R/W-0	R/W-0	R/W-0	R/W-0	R/W-0		R/W-0

Bit 0 : (remain its value to "0" unchanged otherwise Comparator and CTCSS function will fail)

Bit 1 : (undefined) not allowed to use

Bit 2(P5SH) : Switch I/O PORT5 high nibble(5~7) or LCD segment signal

0 → (P55 ~ P57 pins are selected) : normal PORT5 high nibble(5~7)

1 → (SEG10 ~ SEG12 pins are selected) : SEGMENT output

Bit 3(PBSL) : Switch I/O PORTB low nibble(0~3) or LCD segment signal

0 → (PB0 ~ PB3 pins are selected) : normal PORTB low nibble(0~3)

1 → (SEG28 ~ SEG25 pins are selected) : SEGMENT output

Bit 4(PBSH) : Switch I/O PORTB high nibble(4~7) or LCD segment signal

0 → (PB5 ~ PB7 pins are selected) : normal PORTB high nibble(4~7)

1 → (SEG24 ~ SEG21 pins are selected) : SEGMENT output

Bit 5(PC5S) : Switch I/O PORTC5 or LCD segment signal

0 → (PC5 pin is selected) : normal PORTC5

1 → (SEG31 pin) : SEGMENT output

Bit 6(PC6S) : Switch I/O PORTC6 or LCD segment signal

0 → (PC6 pin is selected) : normal PORTC6

1 → (SEG30 pin) : SEGMENT output

Bit 7(PC7S) : Switch I/O PORTC7 or LCD segment signal

0 → (PC7 pin is selected) : normal PORTC7

1 → (SEG29 pin) : SEGMENT output

**IOCD (TONE1 control, Clock source, Prescaler of CN1 and CN2)**
**PAGE0 (TONE1 control)**

7	6	5	4	3	2	1	0
T17	T16	T15	T14	T13	T12	T11	T10
R/W-0	R/W-0	R/W-0	R/W-0	R/W-0	R/W-0	R/W-0	R/W-0

Bit 0 ~ Bit 7 (T10 ~ T17) : Tone generator 1's frequency divider and power control

Please Run in Normal mode.

Clock source = 111957Hz and Freq. = 111957Hz / N, where N is divider value for T1A ~ T10 (T1A ~ T18 are in the IOCE PAGE0 Bit 2 ~ Bit 0.

If T20 ~ T18 are all "0", then

T17 ~ T10 = '11111111' => Tone generator1 will has 439Hz SIN wave output.

:

T17~T10 = '00000010' => Tone generator1 will has 55978Hz SIN wave output.

T17~T10 = '00000001' => DC bias voltage output

T17~T10 = '00000000' => Power off



**PAGE1 (Clock source and prescaler for COUNTER1 and COUNTER2)**

7	6	5	4	3	2	1	0
CNT2S	C2_PSC2	C2_PSC1	C2_PSC0	CNT1S	C1_PSC2	C1_PSC1	C1_PSC0
R/W-0	R/W-0	R/W-0	R/W-0	R/W-0	R/W-0	R/W-0	R/W-0

Bit 0 ~ Bit 2 (C1\_PSC0 ~ C1\_PSC2) : COUNTER1 prescaler ratio

C1_PSC2	C1_PSC1	C1_PSC0	COUNTER1
0	0	0	1:2
0	0	1	1:4
0	1	0	1:8
0	1	1	1:16
1	0	0	1:32
1	0	1	1:64
1	1	0	1:128
1	1	1	1:256

Bit 3(CNT1S) : COUNTER1 clock source

0/1 → 16.384kHz/system clock

Bit 4 ~ Bit 6 (C2\_PSC0 ~ C2\_PSC2) : COUNTER2 prescaler ratio

C2_PSC2	C2_PSC1	C2_PSC0	COUNTER2
0	0	0	1:2
0	0	1	1:4
0	1	0	1:8
0	1	1	1:16
1	0	0	1:32
1	0	1	1:64
1	1	0	1:128
1	1	1	1:256

Bit 7(CNT2S) : COUNTER2 clock source

0/1 → 16.384kHz/system clock

**IOCE (Interrupt mask, TONE1 extra control bits, CTCSS control switches)**

**PAGE0 (Interrupt mask, TONE1 extra three control bits)**

7	6	5	4	3	2	1	0
-	-	-	-	-	T1A	T19	T18
R/W-0	R/W-0	R/W-0	R/W-0		R/W-0	R/W-0	R/W-0

Bit 0 ~ Bit 2 (T18 ~ T1A) : Most significant 3 bits of Tone generator 1's frequency divider and power control

These 3 bits and other 8 bits (IOCA PAGE0 bit 7 ~ bit0) are assembled as 11-bit frequency divider for Tone generator 1

Bit 3 : (undefined) not allowed to use

Bit 4 ~ Bit 7 : (remain these values to "0" otherwise it will generate unpredicted interrupts)

**PAGE1 (CTCSS control switches)**

7	6	5	4	3	2	1	0
TXPWR	RXPWR	BFPWR	LFPWR	ASW4	ASW3	ASW2	ASW1
R/W-0	R/W-0	R/W-0	R/W-0	R/W-0	R/W-0	R/W-0	R/W-0

Bit 0(ASW1) : Analog switch-1 control for multi-plexer in the CTCSS block

0 → Select VRX1 input

1 → Select VTX1 input

- Bit 1(ASW2) : Analog switch-2 control for multi-plexer in the CTCSS block
  - 0 → Select VRX2 output
  - 1 → Select VTX2 output
- Bit 2(ASW3) : Analog switch-3 control for multi-plexer in the CTCSS block
  - 0 → Select VRX3 input
  - 1 → Select VTX3 input, **when this input is selected, it will has -6dB attenuation**
- Bit 3(ASW4) : Analog switch-4 control for multi-plexer in the CTCSS block
  - 0 → Select VRX4 output
  - 1 → Select VTX4 output, **when this output is selected, it will has -4dB attenuation**
- Bit 4(LFPWR) : Power control for sub-audio LPF in the CTCSS block. 0/1 → disable/enable
- Bit 5(BFPWR) : Power control for audio BPF in the CTCSS block. 0/1 → disable/enable
- Bit 6(RXPWR) : RX power control for the CTCSS block 0/1 → disable/enable
- Bit 7(TXPWR) : TX power control for the CTCSS block 0/1 → disable/enable

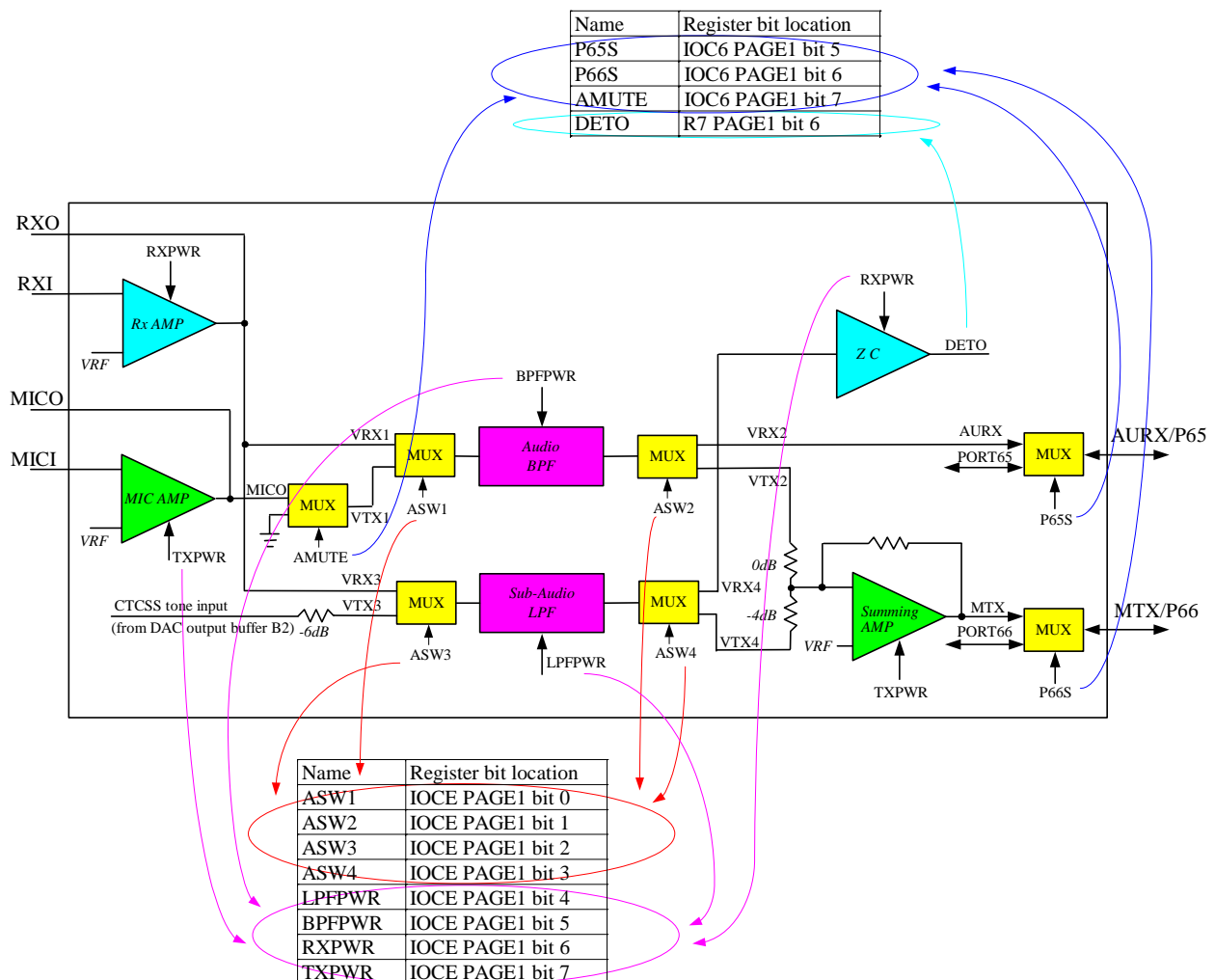

Fig.14 CTCSS block

**IOCF (Interrupt mask)**

(Interrupt mask register)

Bit7	Bit6	Bit5	Bit4	Bit3	Bit2	Bit1	Bit0
INT3	DETO	INT2	INT1	INT0	CNT2	CNT1	TCIF
R/W-0	R/W-0	R/W-0	R/W-0	R/W-0	R/W-0	R/W-0	R/W-0

Bit 0 ~ 7 : interrupt enable bit

0 → disable interrupt

1 → enable interrupt

The status after interrupt and the interrupt sources list as the table below.

Interrupt signal	IDLE mode	GREEN mode	NORMAL mode
	RA(7,6)=(1,0) + SLEP	RA(7,6)=(x,0) no SLEP	RA(7,6)=(x,1) no SLEP
TCC time out IOCF bit0=1 And "ENI"	(1) Wake-up (2) Interrupt (jump to address 8 at page0) (3) after RETI instruction, jump to SLEP Next instruction	Interrupt (jump to address 8 at page0)	Interrupt (jump to address 8 at page0)
COUNTER1 time out IOCF bit1=1 And "ENI"	(1) Wake-up (2) Interrupt (jump to address 8 at page0) (3) after RETI instruction, jump to SLEP Next instruction	Interrupt (jump to address 8 at page0)	Interrupt (jump to address 8 at page0)
COUNTER2 time out IOCF bit2=2 And "ENI"	(1) Wake-up (2) Interrupt (jump to address 8 at page0) (3) after RETI instruction, jump to SLEP Next instruction	Interrupt (jump to address 8 at page0)	Interrupt (jump to address 8 at page0)
PORT7(0~3) IOCF bit3 or bit4 or bit5 or bit7=1 And "ENI"	(1) Wake-up (2) Interrupt (jump to address 8 at page0) (3) after RETI instruction, jump to SLEP Next instruction	Interrupt (jump to address 8 at page0)	Interrupt (jump to address 8 at page0)
DETO IOCF bit6 = 1 And "ENI"	No function	No function	Interrupt (jump to address 8 at page0)

<Note> PORT70 's interrupt function is controlled by IOCF bit 3. It's falling edge or rising edge trigger (controlled by CONT register bit7).

PORT7(1~3) 's wakeup functions are controlled by IOCF bit (4,5,7). They are falling edge trigger.

DETO's interrupt function is controlled by IOCF bit 6. It's falling edge trigger, falling and rising edge trigger (set by RD PAGE0 bit 7).

<ps> It only happens when master and 16.386kHz mode is selected.

## VII.4 I/O Port

The I/O registers are bi-directional tri-state I/O ports. The I/O ports can be defined as "input" or "output" pins by the I/O control registers under program control. The I/O data registers and I/O control registers are both readable and writable. The I/O interface circuit is shown as follows.

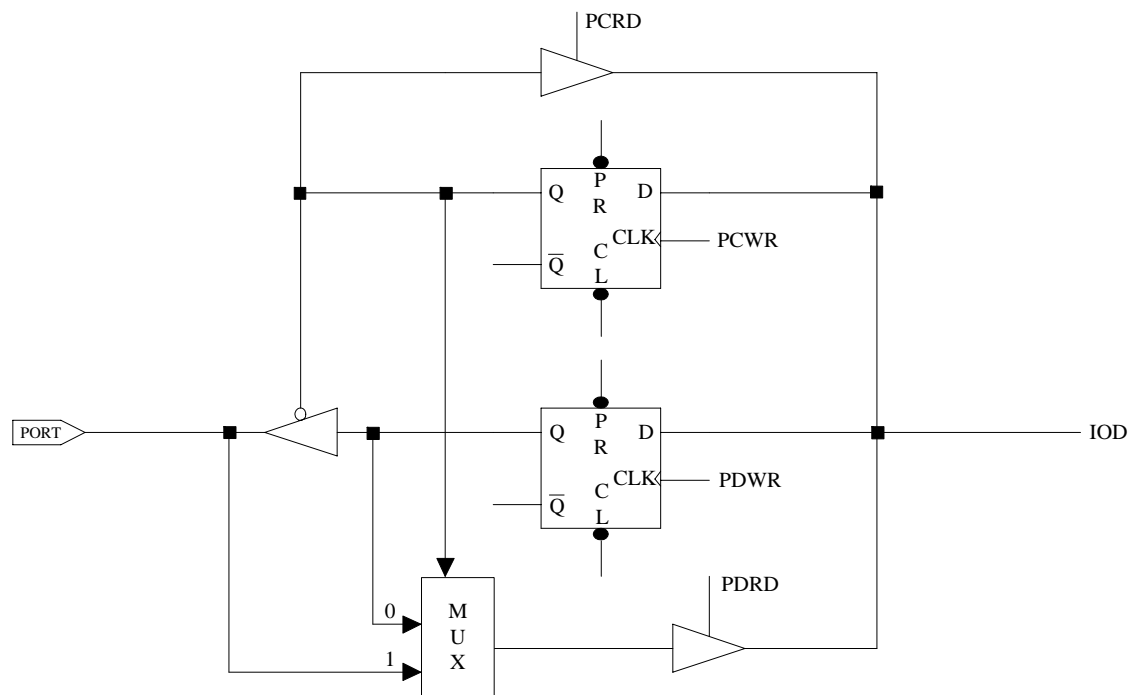

Fig.15 The circuit of I/O port and I/O control register

## VII.5 RESET

The RESET can be caused by

- (1) Power on voltage detector reset (/POVD) and power on reset
- (2) WDT timeout. (if enabled and in GREEN or NORMAL mode)
- (3) /RESET pin pull low

<Note> At case (1), /POVD is controlled by CODE OPTION. If you enable /POVD, CPU will reset at under 1.8V and CPU will consume more current about 5uA. It is used for low voltage reset/ And the power-on reset is a circuit which is always enabled and only works on initially power-on reset. It will reset CPU at about 1.4V and consume about 0.5uA.

Once the RESET occurs, the following functions are performed.

- The oscillator is running, or will be started.
- The Program Counter (R2) is set to all "0".
- When power on, the upper 3 bits of R3 and the upper 2 bits of R4 are cleared.
- The Watchdog timer and prescaler counter are cleared.
- The Watchdog timer is disabled.
- The CONT register is set to all "1"
- The other register (bit 7 ~ bit 0) default values are as follows.

Operation registers :

Address	R register PAGE0	R register PAGE1	R register PAGE2	IOC register PAGE0	IOC register PAGE1
0x4	00xxxxxx				
0x5	xxxx0000	xxxx0000		111x0000	00000000
0x6	xxxxxxxx	xxxxxxxx		11111111	00000000
0x7	xxxxxxxx	xxxxxx00		11111111	00000000
0x8	xxxxxxxx	00000000		11111111	00000000
0x9	xxxxxxxx	xxxxxxxx		11111111	00000000
0xA	00011x00	11111111	0xxxxxxx	00000000	00000xxx
0xB	xxxxxxxx			11111111	
0xC	xxxxxxxx	00000000		11111111	000000x0
0xD	0xxxx000	00000000		00000000	00000000
0xE	xxxx0000	11111111		0000x000	00000000
0xF	00000000			00000000	

## VII.6 Wake-up

The controller has two types of sleep mode for power saving :

- (1) SLEEP mode, RA(7) = 0 + "SLEP" instruction

The controller will turn off all the CPU and crystal. Other circuit with power control like key tone control or PLL control (which has enable register), user has to turn it off by software.

- (2) IDLE mode, RA(7) = 1 + "SLEP" instruction.

The controller will turn CPU off, but the crystal.

Wake-up from SLEEP mode

- (1) WDT time out
- (2) External interrupt
- (3) /RESET pull low

All these cases will reset controller , and run the program at address zero. The status just like the power on reset.

Be sure to enable circuit at case (1) or (2).

Wake-up from IDLE mode

- (1)WDT time out
- (2) external interrupt
- (3) internal interrupt like counters

All these cases, user has to enable circuit before entering IDLE mode. After wake-up, all the register will keep values just like into "SLEP" instruction before.

At case (2) or (3), controller will wake up and jump to address 0x08 for interruption sub-routine. After finishing sub-routine ("RETI" instruction), program will jump to the next instruction from "SLEP" instruction.

## VII.7 Interrupt

RF is the interrupt status register which records the interrupt request in flag bit. IOCF is the interrupt mask register. Global interrupt is enabled by ENI instruction and is disabled by DISI instruction. When one of the interrupts (when enabled) generated, will cause the next instruction to be fetched from address 008H. Once in the interrupt service routine, the source of the interrupt can be determined by polling the flag bits in the RF register.



The interrupt flag bit must be cleared in software before leaving the interrupt service routine and enabling interrupts to avoid recursive interrupts.

## VII.8 Instruction Set

Instruction set has the following features:

- (1) Every bit of any register can be set, cleared, or tested directly.
- (2) The I/O register can be regarded as general register. That is, the same instruction can operate on I/O register.

The symbol "R" represents a register designator which specifies which one of the 64 registers (including operational registers and general purpose registers) is to be utilized by the instruction. Bits 6 and 7 in R4 determine the selected register bank. "b" represents a bit field designator which selects the number of the bit, located in the register "R", affected by the operation. "k" represents an 8 or 10-bit constant or literal value.

INSTRUCTION BINARY	HEX	MNEMONIC	OPERATION	STATUS AFFECTED	Instruction cycle
0 0000 0000 0000	0000	NOP	No Operation	None	1
0 0000 0000 0001	0001	DAA	Decimal Adjust A	C	1
0 0000 0000 0010	0002	CONTW	A → CONT	None	1
0 0000 0000 0011	0003	SLEP	0 → WDT, Stop oscillator	T,P	1
0 0000 0000 0100	0004	WDTC	0 → WDT	T,P	1
0 0000 0000 rrrr	000r	IOW R	A → IOCR	None	1
0 0000 0001 0000	0010	ENI	Enable Interrupt	None	1
0 0000 0001 0001	0011	DISI	Disable Interrupt	None	1
0 0000 0001 0010	0012	RET	[Top of Stack] → PC	None	2
0 0000 0001 0011	0013	RETI	[Top of Stack] → PC Enable Interrupt	None	2
0 0000 0001 0100	0014	CONTR	CONT → A	None	1
0 0000 0001 rrrr	001r	IOR R	IOCR → A	None	1
0 0000 0010 0000	0020	TBL	R2+A → R2 bits 9,10 do not clear	Z,C,DC	2
0 0000 0011 0000	0030	MUL	(MR) (+/-) (s/us X)*(s/us Y) → MR	None	1
0 0000 01rr rrrr	00rr	MOV R,A	A → R	None	1
0 0000 1000 0000	0080	CLRA	0 → A	Z	1
0 0000 11rr rrrr	00rr	CLR R	0 → R	Z	1
0 0001 00rr rrrr	01rr	SUB A,R	R-A → A	Z,C,DC	1
0 0001 01rr rrrr	01rr	SUB R,A	R-A → R	Z,C,DC	1
0 0001 10rr rrrr	01rr	DECA R	R-1 → A	Z	1
0 0001 11rr rrrr	01rr	DEC R	R-1 → R	Z	1
0 0010 00rr rrrr	02rr	OR A,R	A ∨ VR → A	Z	1
0 0010 01rr rrrr	02rr	OR R,A	A ∨ VR → R	Z	1
0 0010 10rr rrrr	02rr	AND A,R	A & R → A	Z	1
0 0010 11rr rrrr	02rr	AND R,A	A & R → R	Z	1

\* This specification are subject to be changed without notice.



0	0011	00rr	rrrr	03rr	XOR A,R	$A \oplus R \rightarrow A$	Z	1
0	0011	01rr	rrrr	03rr	XOR R,A	$A \oplus R \rightarrow R$	Z	1
0	0011	10rr	rrrr	03rr	ADD A,R	$A + R \rightarrow A$	Z,C,DC	1
0	0011	11rr	rrrr	03rr	ADD R,A	$A + R \rightarrow R$	Z,C,DC	1
0	0100	00rr	rrrr	04rr	MOV A,R	$R \rightarrow A$	Z	1
0	0100	01rr	rrrr	04rr	MOV R,R	$R \rightarrow R$	Z	1
0	0100	10rr	rrrr	04rr	COMA R	$/R \rightarrow A$	Z	1
0	0100	11rr	rrrr	04rr	COM R	$/R \rightarrow R$	Z	1
0	0101	00rr	rrrr	05rr	INCA R	$R+1 \rightarrow A$	Z	1
0	0101	01rr	rrrr	05rr	INC R	$R+1 \rightarrow R$	Z	1
0	0101	10rr	rrrr	05rr	DJZA R	$R-1 \rightarrow A$ , skip if zero	None	2 if skip
0	0101	11rr	rrrr	05rr	DJZ R	$R-1 \rightarrow R$ , skip if zero	None	2 if skip
0	0110	00rr	rrrr	06rr	RRCA R	$R(n) \rightarrow A(n-1)$ $R(0) \rightarrow C, C \rightarrow A(7)$	C	1
0	0110	01rr	rrrr	06rr	RRC R	$R(n) \rightarrow R(n-1)$ $R(0) \rightarrow C, C \rightarrow R(7)$	C	1
0	0110	10rr	rrrr	06rr	RLCA R	$R(n) \rightarrow A(n+1)$ $R(7) \rightarrow C, C \rightarrow A(0)$	C	1
0	0110	11rr	rrrr	06rr	RLC R	$R(n) \rightarrow R(n+1)$ $R(7) \rightarrow C, C \rightarrow R(0)$	C	1
0	0111	00rr	rrrr	07rr	SWAPA R	$R(0-3) \rightarrow A(4-7)$ $R(4-7) \rightarrow A(0-3)$	None	1
0	0111	01rr	rrrr	07rr	SWAP R	$R(0-3) \leftrightarrow R(4-7)$	None	1
0	0111	10rr	rrrr	07rr	JZA R	$R+1 \rightarrow A$ , skip if zero	None	2 if skip
0	0111	11rr	rrrr	07rr	JZ R	$R+1 \rightarrow R$ , skip if zero	None	2 if skip
0	100b	bbrr	rrrr	0xxx	BC R,b	$0 \rightarrow R(b)$	None	1
0	101b	bbrr	rrrr	0xxx	BS R,b	$1 \rightarrow R(b)$	None	1
0	110b	bbrr	rrrr	0xxx	JBC R,b	if $R(b)=0$ , skip	None	2 if skip
0	111b	bbrr	rrrr	0xxx	JBS R,b	if $R(b)=1$ , skip	None	2 if skip
1	00kk	kkkk	kkkk	1kkk	CALL k	$PC+1 \rightarrow [SP]$ $(Page, k) \rightarrow PC$	None	2
1	01kk	kkkk	kkkk	1kkk	JMP k	$(Page, k) \rightarrow PC$	None	2
1	1000	kkkk	kkkk	18kk	MOV A,k	$k \rightarrow A$	None	1
1	1001	kkkk	kkkk	19kk	OR A,k	$A \vee k \rightarrow A$	Z	1
1	1010	kkkk	kkkk	1Akk	AND A,k	$A \& k \rightarrow A$	Z	1
1	1011	kkkk	kkkk	1Bkk	XOR A,k	$A \oplus k \rightarrow A$	Z	1
1	1100	kkkk	kkkk	1Ckk	RETL k	$k \rightarrow A, [Top\ of\ Stack] \rightarrow PC$	None	2
1	1101	kkkk	kkkk	1Dkk	SUB A,k	$k-A \rightarrow A$	Z,C,DC	1
1	1110	0000	0001	1E01	INT	$PC+1 \rightarrow [SP]$ $001H \rightarrow PC$	None	1
1	1110	100k	kkkk	1E8k	PAGE k	$K \rightarrow R5(4:0)$	None	1
1	1111	kkkk	kkkk	1Fkk	ADD A,k	$k+A \rightarrow A$	Z,C,DC	1

VII.9 Signal and control paths for DAC, DAC tone gen., CTCSS and Comparator

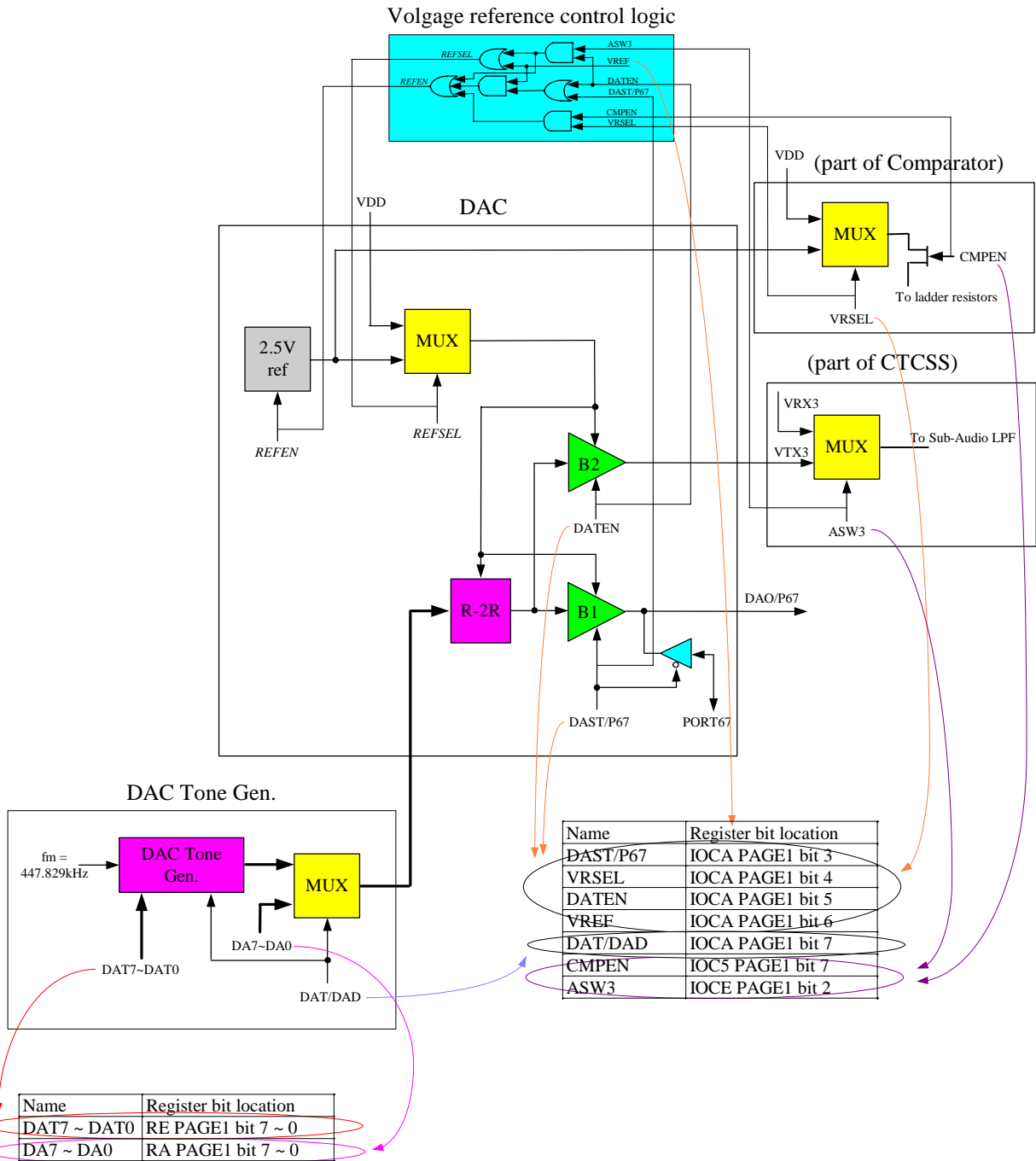

ps. REFEN, REFSEL are not register bits.

Fig.16 Signal and control paths for analog circuit

The Fig.16 above try to explain how to use built-in 8-bit R-2R DAC. This DAC can be used as general DAC; here is call “DAC general mode”. Also it can be used as FRS CTCSS tone generation; here is called DAC tone generator mode. When you use DAC general mode, you have to software program DAC input data DA7 ~ DA0 bits with different points of value for tone generation. When you use DAC tone generator mode, you just need to set DAT7 ~ DAT0 bits and then the hardware “DAC Tone Gen.” will auto-program DAC to generate corresponding frequency signal output. Using this feature, it is easy and software free to generate accurate CTCSS tone.

\* This specification are subject to be changed without notice.



- (1) DAC program mode :
- The below item “1” is for DAC general mode. The below item “2,3” are for DAC tone generator mode.
1. DAT/DAD = 0 → DAC general mode, software-program DAC from DA7 ~ DA0 register bits , disable DAC tone generator ◦
  2. DAT/DAD = 1 → DAC tone generator mode, hardware-program DAC by setting DAT7 ~ DAT0 register bits, enable DAC tone generator ◦
  3. DAT7 ~ DAT0 = 0 → Disable DAC tone generator ◦
- (2) DAC output paths :
- DAST/P67 is used to enable DAC output buffer B1. DATEN is used to enable DAC output buffer B2.
1. External : DAC output from its output buffer B1 to DAO/P67 pin ◦  
DAST/P67 = 1 → power on DAC, enable DAC output buffer B1, output sent to DAO/P67 pin ◦
  2. Internal : DAC output from its output buffer B2 to CTCSS Sub-audio LPF ◦  
DATEN = 1 → power on DAC, enable DAC output buffer B2, output sent to CTCSS VTX3 ◦
- (3) Using 2.5V ref and DAC

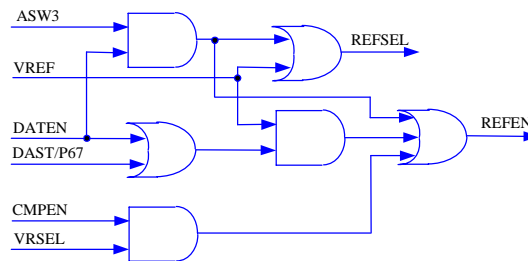

Fig.17 Voltage reference control logic

“2.5V ref.” is the reference voltage used in DAC, Comparator or CTCSS. The voltage reference control logic process these combination use. For this reference used in Comparator, you just only take care of CMPEN and VRSEL bits. For this reference used in others, you need to set ASW3, VREF, DATEN and DAST/P67. The following table shows the least two bits setting to logic “1” (CMPEN=VRSEL=1 or ASW3=DATEN=1 or VREF=DATEN=1 or VREF=DAST/P67=1) will “select 2.5V and enable 2.5V ref”.

When REFSEL = 1, the 2.5V ref is select not VDD. (select 2.5V ref)

When REFEN = 1, the 2.5V ref is power on. (2.5V ref enable)

ASW3	VREF	DATEN	DAST/P67	CMPEN	VRSEL	Function
x	x	x	x	1	1	select 2.5V ref, enable 2.5V ref, enable Comparator
1	x	1	x	x	x	select 2.5V ref, enable 2.5V ref, enable DAC, enable buffer B2, buffer B2 output to CTCSS LPF
x	1	0	1	x	x	select 2.5V ref, enable 2.5V ref, enable DAC, enable buffer B1, buffer B1 output to DAO/P67 pin

- (4) Select DAO/P67 pin as normal I/O P67  
Set DAST/P67 = 0 to select normal I/O P67.
- (5) Using DAC general mode
1. DAT/DAD = 0 → select DAC general mode ◦
  2. Program DA7 ~ DA0 ◦
  3. Enable DAC, enable DAC output buffer, select DAC reference source ◦
- (6) Using DAC tone generator mode
1. DAT/DAD = 1 → select DAC tone generator mode ◦
  2. Program DAT7 ~ DAT0 = 1 to 255. (If DAT7 ~ DAT0 = 0, DAC tone gen. is disabled.) ◦
  3. Enable DAC, enable DAC output buffer, select DAC reference source ◦
- Ps. When DAC tone output is set to CTCSS Sub-audio LPF(ASW3=DATEN=1 or VREF=DATEN=1), it will be forced to select 2.5V ref by voltage reference control logic. When its output is set to DAO/P67 pin, reference voltage can be selected as VDD or 2.5V.  
Ref to Page 18,19 for CTCSS tone generation table.*

## VII.10 CTCSS block

### VII.10.1 Block control and signal flow description

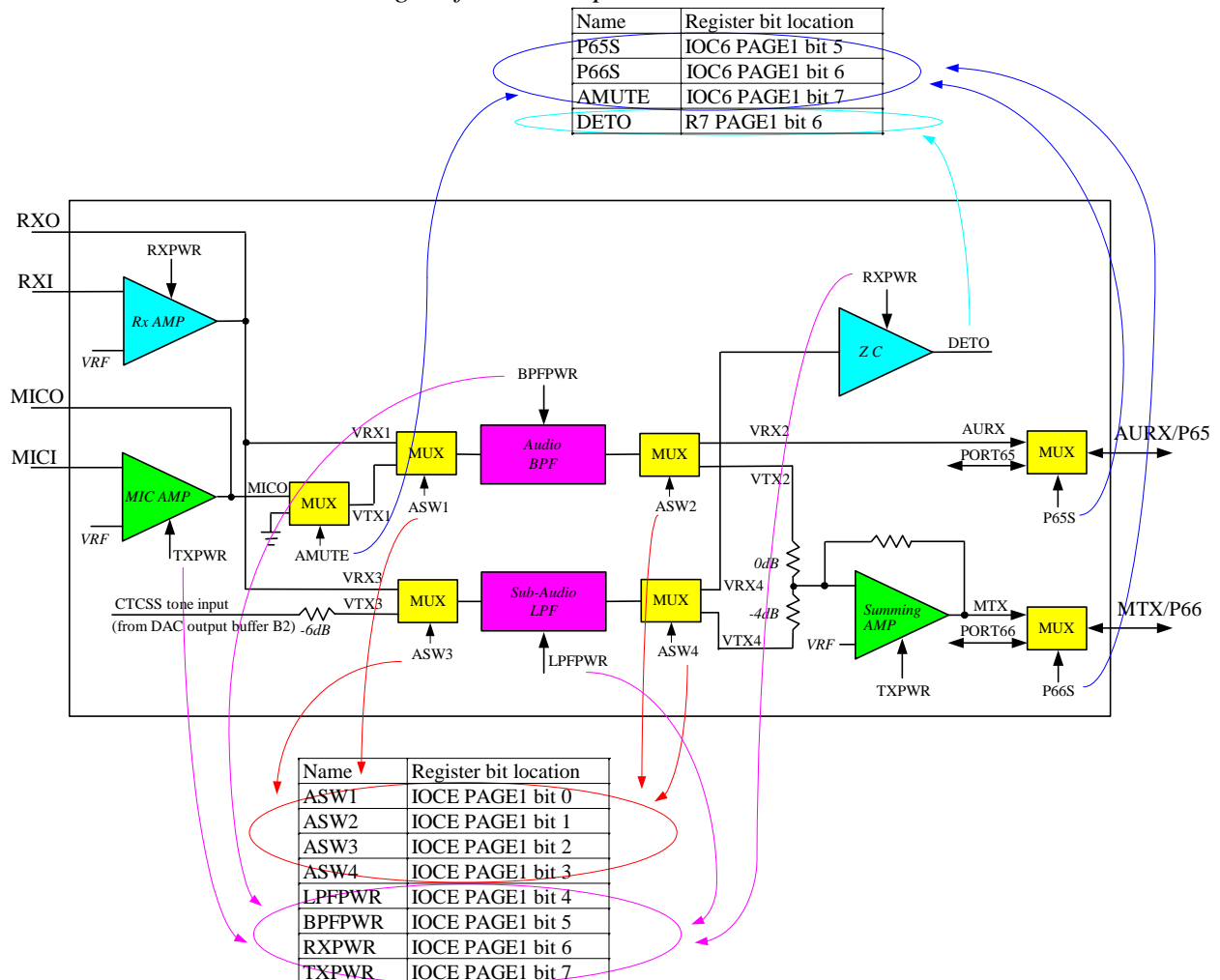

CTCSS block on page 36 Fig.14 is the key feature for FRS baseband signal processing. For receiving path, it receives the RF demodulator output signal and extract the audio output signal to AURX pin. Also it decodes CTCSS tone and its decoding data is shown in the DETO. For transmitting path, it combines audio signal from Mic Amp and CTCSS signal from DAC tone generator(as description in VII.9 section) thru MTX output to RF modulator input end. CTCSS block consists of amplifiers, analog switch, filters and zero-crossing detector which descriptions are shown below.

- **RX AMP** : (Receiving amplifier) It accepts RF demodulator output signals which combine demodulated audio and CTCSS tone.
- **MIC AMP** : (Microphone amplifier) It is the audio input amplifier.
- **MUX** : (Analog multiplexer switch) It is used for analog signal path switching.
- **Audio BPF** : (Audio band pass filter) This audio BPF has pass band 300Hz ~ 3.4kHz. It is used to let audio signal pass through and filter out CTCSS tones. It plays an important role in extracting audio signal. Also it cut out unwanted signal while audio signal transmitting.
- **Sub-Audio LPF** : (Sub-audio low pass filter) This sub-audio LPF has pass band 253Hz. It is used to let CTCSS tone pass through and filters out audio signal. It plays an important in extracting CTCSS tone. Also it cut out unwanted signal while CTCSS tone transmitting.
- **Summing AMP** : (Summing amplifier) It is an analog signal mixer for audio signal and CTCSS tone transmitting. CTCSS tone will be attenuated about 10dB before signal mixing.
- **ZC** : (Zero-crossing detector) This detector transforms CTCSS tone signal from analog form to digital form. It will be the CTCSS tone detection.

- Description for register control bits  
 ASW1 ~ ASW4 for analog input/output signal path switching  
 RXPWR for power control of receiving RX AMP and ZC  
 TXPWR for power control of transmitting MIC AMP and Summing AMP  
 AMUTE for MIC AMP output muting  
 P65S for receiving audio output pin AURX or port P65 pin switching  
 P66S for transmitting output pin MTX or port P66 pin switching

The following is the above CTCSS block signal flow and it is easy to use these figures to explain how CTCSS works. ('blue' highlight means signal flow and switch setting)

(1) RX : receiving CTCSS tone

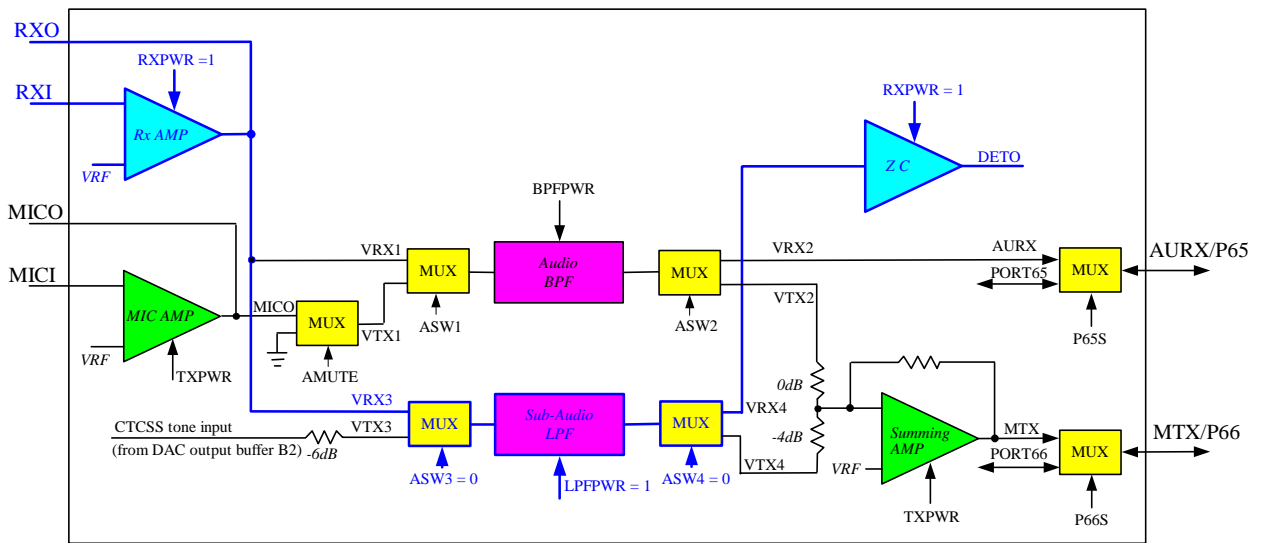

Fig.18

(2) RX : receiving audio

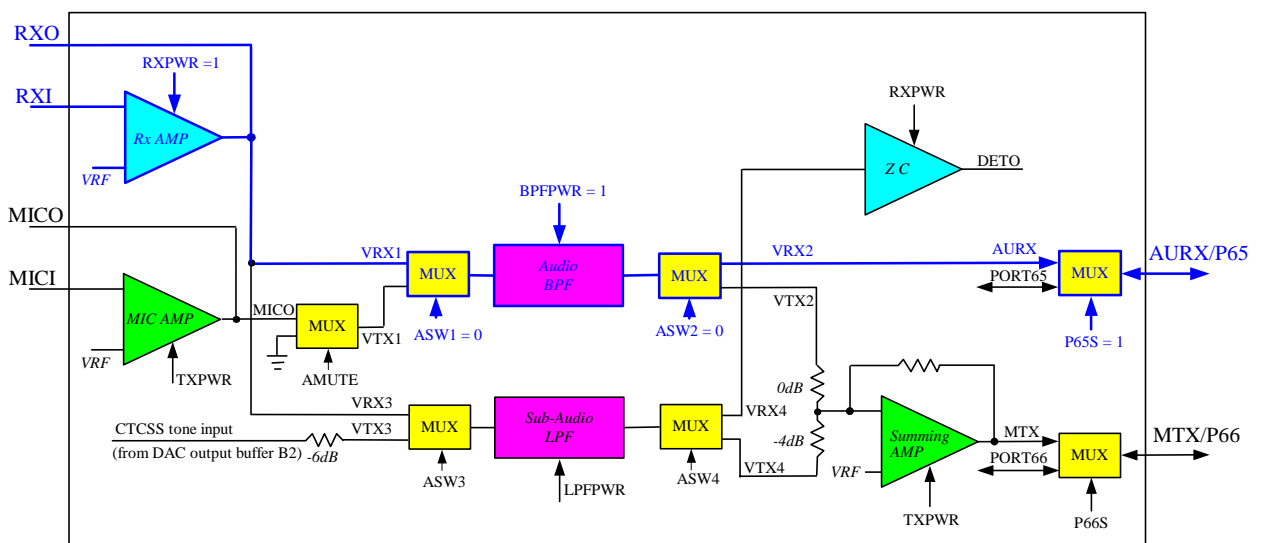

Fig.19

(3) TX : transmitting audio

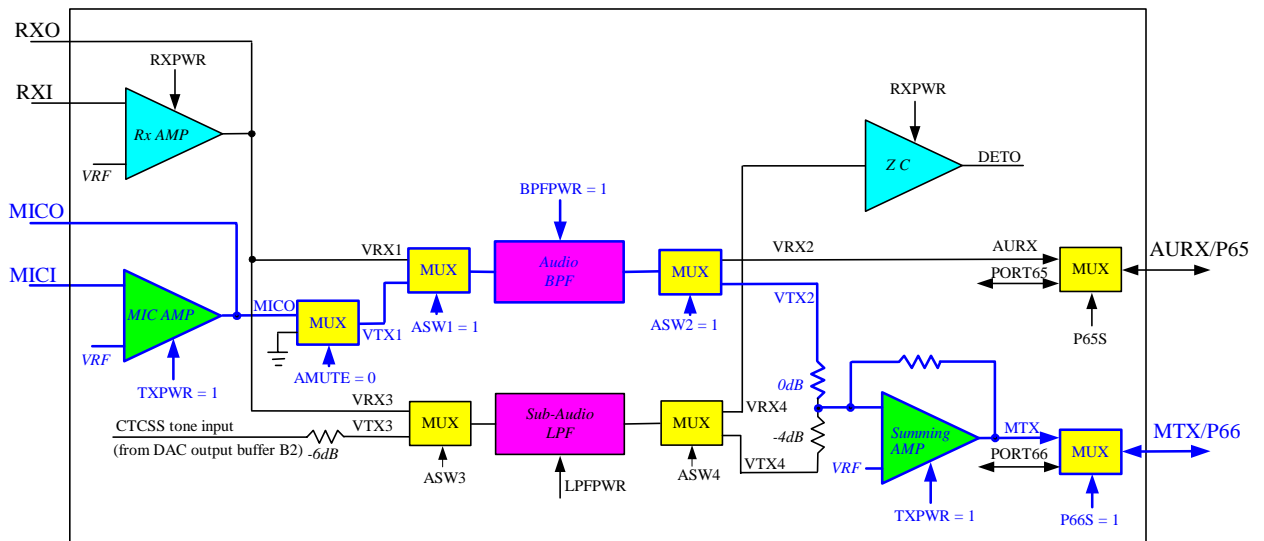

Fig.20

(4) TX : transmitting CTCSS tone

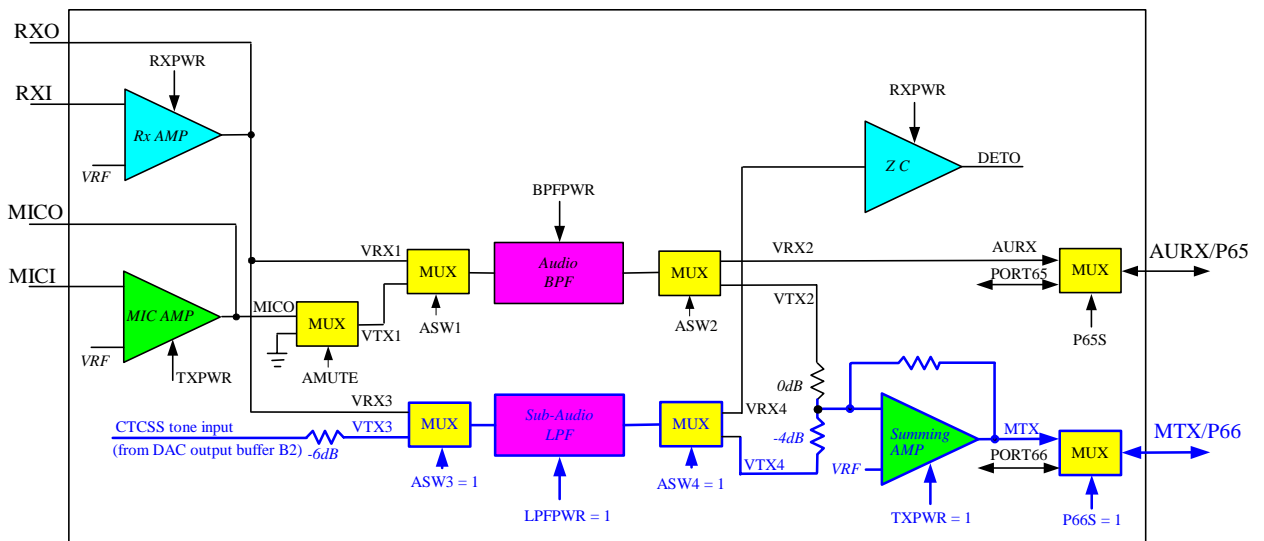

Fig.21

### VII.10.2 CTCSS Block reference voltage

In VII.10.2 CTCSS block, there is VRF for RX AMP, MIC AMP, Summing AMP and so on. This bias VRF is come from VDD or 2.5V ref. That means  $VRF = VDD/2$  or  $2.5V/2$ . When  $ASW3=DATEN=1$  or  $VREF=DATEN=1$ , then  $REFEN$  and  $REFSEL$  will be set to "1" by voltage control logic as description in VII.9 (3). At this time, 2.5V ref. is selected on and  $VRF = 2.5V/2$ . In other case, if voltage control logic don't set  $REFEN$  and  $REFSEL$  to "1", then VDD is selected on and  $VRF = VDD/2$ .

### VII.10.3 Output driving capacity consideration for AURX/P65 and MTX/P66

For AURX/P65 and MTX/P66 output pins, their output driving capacity is not much. Their output loading impedance can use too small otherwise their output swing will be reduced. *User has to follow the following table “Min. loading impedance for max. swing” to get max. output swing.*

VDD = 5V

Output pin	Condition	Max. swing for no loading	Min. loading impedance for max. swing (typical value)
AURX/P65	VRF = VDD/2	3.8 Vp-p	200k ohms
	VRF = 2.5V/2	2 Vp-p	82k ohms
MTX/P66	VRF = VDD/2	1.6 Vp-p	51k ohms
	VRF = 2.5V/2	0.8 Vp-p	27k ohms

### VII.10.4 Special application on Audio/CTCSS tone mixing output

Generally speaking, users can use built-in DAC tone gen.(described in VII.9) to generate CTCSS tone accompanied with audio on MTX/P66 pin output without problem. For some customers, due to modulation index criteria of their FM modulator cannot accept built-in CTCSS tone because this level is too large for them to use.

In this case, there are two ways to solve this problem :

- (1) One way is not to use built-in DAC tone gen. but need to program built-in DAC to generate CTCSS tone by user software algorithm. User software algorithm can normalize the final CTCSS tone level to their requirement without adding any external elements.
- (2) The other way is still to use built-in DAC tone gen. but need some external element to attenuate CTCSS tone on DAO/P67 pin. Program some control bit to let CTCSS output on DAO/P67 pin refer to VII.9 (3) description). Because DAO/P67 output is stair-case waveform, we need put simple RC LPF circuit to smooth output waveform before CTCSS attenuation circuit. Also RC LPF has some attenuation effect. It depends on its cut-off frequency of LPF. User can design by his own way. There are two suggestion circuits for your reference as following.

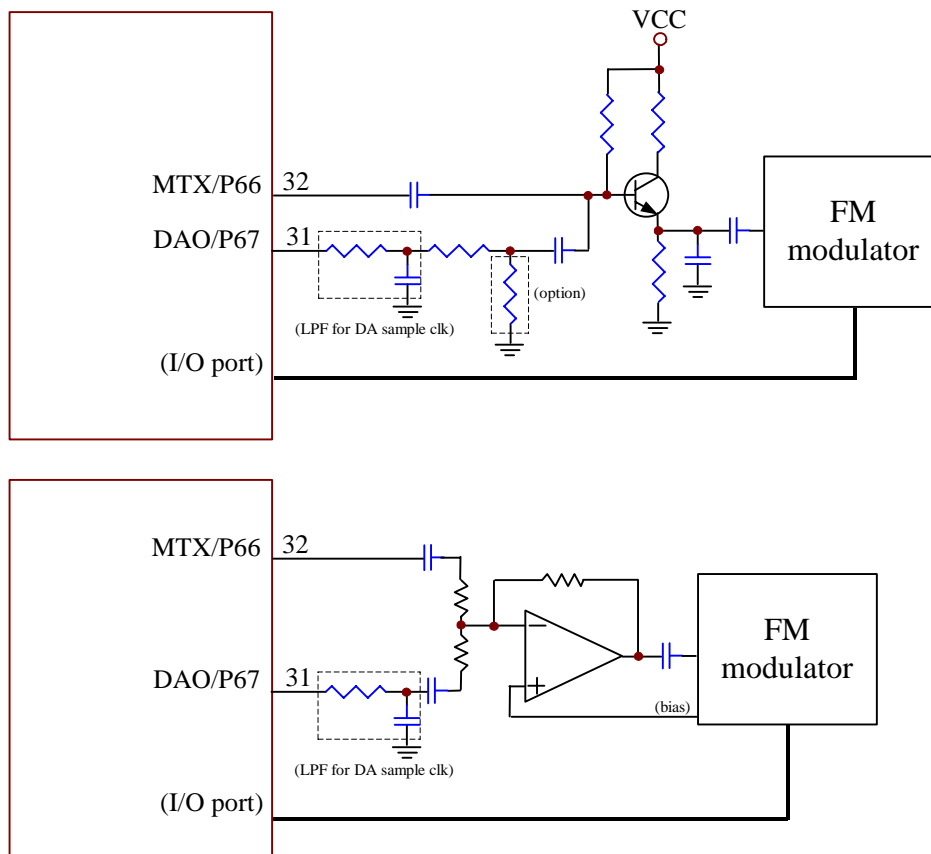

### VII.11 8-bit R-2R DAC

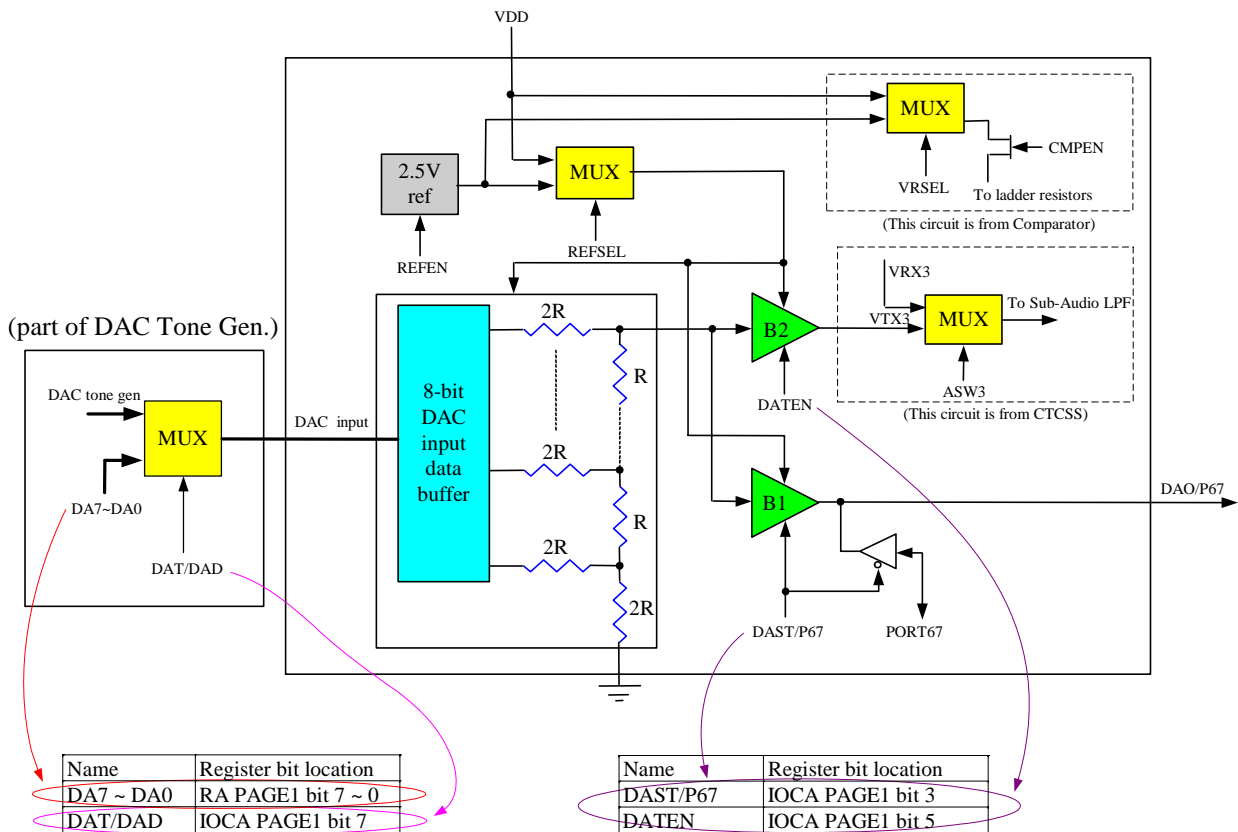

ps. Please refer to “Voltage reference control logic” to set DAC reference.

Fig.22 DAC block

In DAC tone generator mode, user can get CTCSS tone output. In other case, DAC is useful in general tone generation such as key tone, alert tone, music and so on. In DAC general mode, only VREF and DAST/P67 bits are relative to DAC reference voltage. DAC reference voltage is come from VDD or 2.5V ref. Setting VREF bit (IOCE PAGE1 bit 6) = 0/1 to select VDD/2.5V as reference. Setting DAST/P67 bit = 1 to power on DAC and also enable output buffer B1. After that, DAC output signal will be sent to DAO/P67 pin.

### VII.12 4-bit Comparator

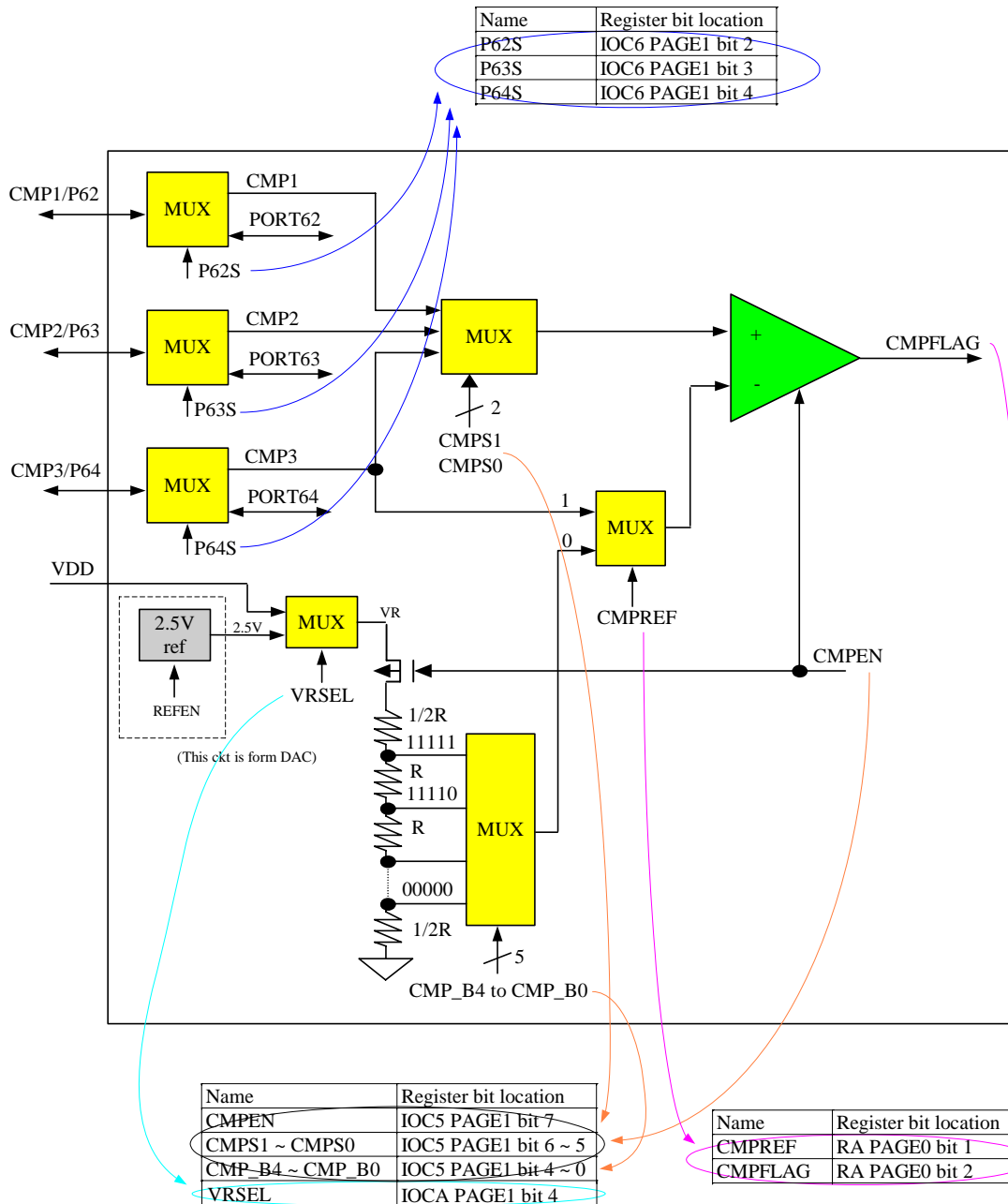

This comparator is not only a single comparator. It consists of 16-R resistor string, 3-channel input and optional external comparison reference source input. The 16-R resistor string acts as 16-level voltage divider which top voltage reference can be selected from VDD or 2.5V ref. Use above register bits to set the whole job. This comparator is used to some applications such as voltage detection, RSSI level, sensor output level and other slow signal level transition detection and so on. This comparator can be called a simple 4-bit low speed ADC but the sampling time is decided by software. For AC frequency detection, it is limited by its output comparator structure. We suggest the detected AC frequency below 1kHz.

\* This specification are subject to be changed without notice.

### VII.13 Programming tone generators

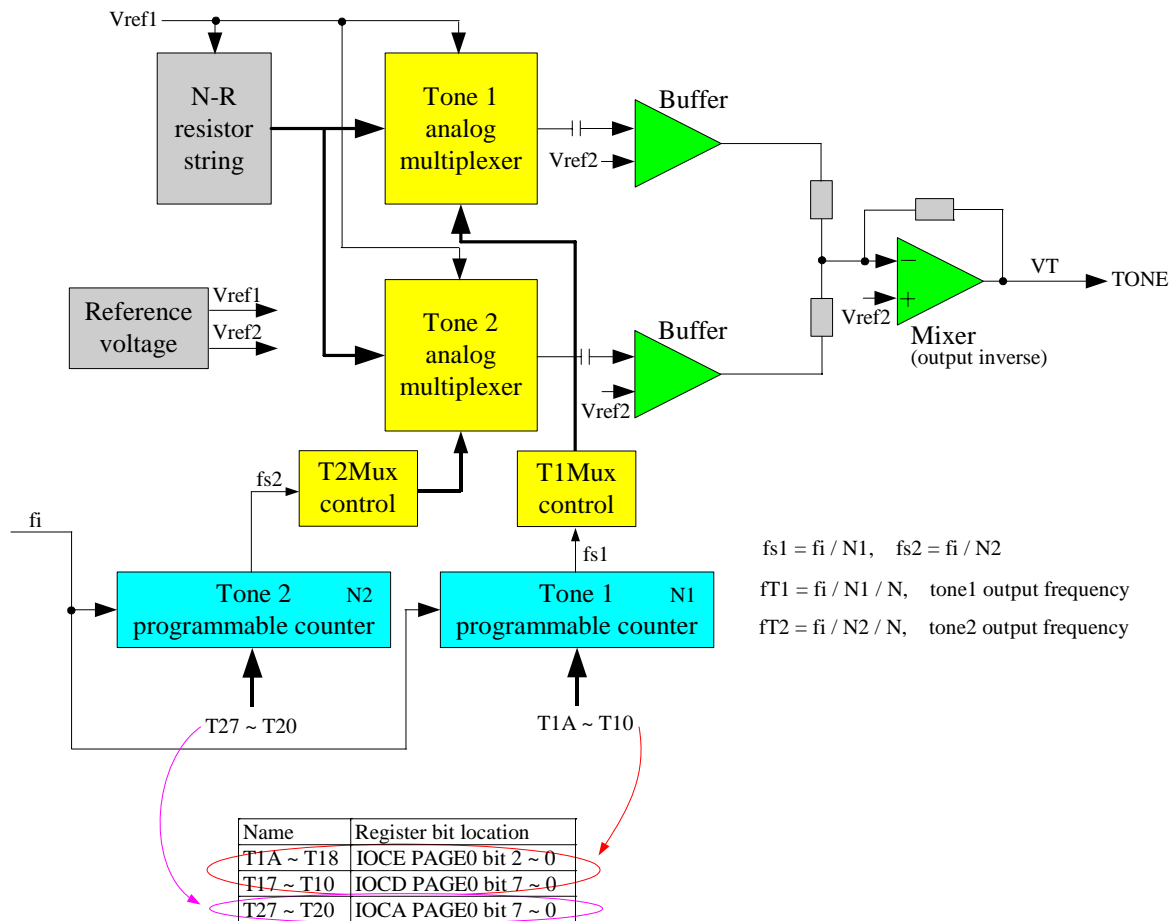

Fig.23 Programming tone generator

Programming tone generators is an universal dual tone generators. It includes Tone 1 and Tone 2 generators which can be combines as dual tones output or either one tone output. The clock source  $f_i$  is come from PLL and divided to required ratio. Tone 1 and Tone 2 are sinewave output. The programming tone generators consists of Tone 1/2 programmable counters, analog multiplexer, N-R resistor string, output buffers, mixer amplifier and reference buffers. N-R resistor is a voltage divider which has different output levels. By programmable counters and analog multiplexer, the hardware will automatically generate individual divider output with circular order back and forth. The output frequency will be  $119957/N1$  for Tone 1 and  $11.957/N2$  for Tone 2, where  $N1$  is 11-bit  $T1A \sim T10$  and  $N2$  is 8-bit  $T17 \sim T10$ .





### VIII. Absolute Operation Maximum Ratings

RATING	SYMBOL	VALUE	UNIT
DC SUPPLY VOLTAGE	VDD	-0.3 To 6	V
INPUT VOLTAGE	V <sub>in</sub>	-0.5 to VDD +0.5	V
OPERATING TEMPERATURE RANGE	T <sub>a</sub>	-30 to 70	°C

### IX. DC Electrical Characteristic

(T<sub>a</sub> = 0°C ~ 70°C, AVDD=VDD=5V±5%, VSS=0V)

Parameter	Symbol	Condition	Min	Typ	Max	Unit
Input leakage current for input pins	IIL1	VIN = VDD, VSS			±1	μA
Input leakage current for bi-directional pins	IIL2	VIN = VDD, VSS			±1	μA
Input high voltage	VIH		2.5			V
Input low voltage	VIL				0.8	V
Input high threshold voltage	VIHT	/RESET, TCC	2.0			V
Input low threshold voltage	VILT	/RESET, TCC			0.8	V
Clock input high voltage	VIHX	OSCI	3.5			V
Clock input low voltage	VILX	OSCI			1.5	V
Output high voltage for PORT5,6,7,8,B	VOH1	IOH = -5mA	2.4			V
Output high voltage for PORT9	VOH2	IOH = -14mA	2.4			V
Output low voltage for PORT5,6,7,8,B	VOL1	IOH = 5mA			0.4	V
Output low voltage for PORT9	VOL2	IOH = 10mA			0.4	V
LCD drive reference voltage	VLCD	VDD=5V, Contrast adjust		4 ~ 5		V
Pull-high current	IPH	Pull-high active input pin at VSS		-10	-15	μA
Power down current (SLEEP mode)	ISB1	All input and I/O pin at VDD, output pin floating, WDT disabled		1	5	μA
Low clock current (GREEN mode)	ISB2	CLK=32.768KHz, All analog circuits disabled, All input and I/O pin at VDD, output		35	50	μA
Low clock current (IDLE mode)	ISB3	CLK=32.768KHz, All analog circuits disabled, All input and I/O pin at VDD, output		30	45	μA
Operating supply current (Normal mode)	ICC1	/RESET=High, CLK=3.582MHz, All analog circuits disabled, output pin floating		1	2	mA
Tone generator reference voltage	Vref2	VREG is regulator output	0.5		0.7	VREG
Tone1 signal strength	V1rms	Root mean square voltage	130	155	180	mV
Tone2 signal strength	V2rms	Root mean square voltage	1.259V1rms			mV

\* This specification are subject to be changed without notice.



2.5Vref for Comparator or DAC

Parameter	Symbol	Condition	Min	Typ	Max	Unit
Internal 2.5V ref. voltage.	2.5VREF	VDD=5V, 25 deg	2.14	2.32	2.44	V
		VDD=3V, 25 deg	2.04	2.25	2.36	V
Reference voltage linearity	$\Delta 2.5V_{REF}/\Delta V_{DD}$	VDD=5.5V ~ 3.0V, 25 deg		5	8	%
		VDD=3.0V ~ 2.7V, 25 deg		8	15	%

Effective VDD reference for Comparator or DAC

Parameter	Symbol	Condition	Min	Typ	Max	Unit
VDD ref. voltage.	VDDref	VDD=5V ~ 2.7V, -20 ~ +50 deg	VDD-0.05	VDD-0.02	VDD	V

(Operation current consumption for analog circuit) (Ta = 0°C ~ 70°C, AVDD=VDD=5V±5%, VSS=0V)

Parameter	Symbol	Condition	Min	Typ	Max	Unit
Programming tone generators						
Operation current for Programming tone generators	I_TONE	TONE1 is power on TONE2 is power on		0.35	0.6	mA
Digital to analog converter						
Operation current for DAC	I_DA			0.65	0.9	mA
Comparator						
Operation current for Comparator	I_CMP			70	120	uA
CTCSS						
Operation current for RX power on	I_RX	RXPWR=1, TXPWR=0 LPFPWR=0, BFPWR=0		0.7	1.0	mA
Operation current for TX power on	I_TX	RXPWR=0, TXPWR=1 LPFPWR=0, BFPWR=0		0.12	0.2	mA
Operation current for LPF power on	I_LPF	RXPWR=0, TXPWR=0 LPFPWR=1, BFPWR=0		0.3	0.5	mA
Operation current for BPF power on	I_BPF	RXPWR=0, TXPWR=0 LPFPWR=0, BFPWR=1		0.3	0.5	mA

\* the spec for above table not including MCU current consumption

## XI. AC Electrical Characteristic

CPU instruction timing (Ta = -30°C ~ 70°C, AVDD=VDD=5V, VSS=0V)

Parameter	Symbol	Condition	Min	Typ	Max	Unit
Input CLK duty cycle	Dclk		45	50	55	%
Instruction cycle time	Tins	32.768kHz		60		us
		3.582MHz		550		ns
Device delay hold time	Tdrh			16		ms
TCC input period	Ttcc	Note 1	(Tins+20)/N			ns
Watchdog timer period	Twdt	Ta = 25°C		16		ms

Note 1: N= selected prescaler ratio.

\* This specification are subject to be changed without notice.

OSC and reset timing characteristics (see Fig.25 for details)

Description	Symbol	Min	Typ	Max	Unit
<b>Oscillator timing characteristic</b>					
OSC start up	32.768kHz	Toscs	400	1500	ms
	3.579MHz PLL		5	10	us
<b>Reset timing characteristic</b>					
The minimum width of reset low pulse	Trst	3			uS
The delay between reset and program start	Tdrs		18		mS

Embedded LCD driver

Symbol	Parameter	Condition	Min	Typ	Max	Unit
Frame	LCD frame frequency	1/8, 1/16 duty		64		Hz

TONE generators for AC Characteristic (AVDD=VDD=5V, Ta=+25°C)

CHARACTERISTIC	Min	Typ	Max	Unit
Tone1/Tone2 signal strength (root mean square voltage)				
Tone1 signal strength V1rms (ps1) ~ -14dBm (600Ω)	130	155	180	mV
Tone2 signal strength V2rms (ps1) ~ -12dBm (600Ω)	1.259V1rms			mV
Tone twist				
(Tone1 – Tone2) twist		-2		dB

(ps1) : V1rms and V2rms has 2 dB difference. It means  $20\log(V2rms/V1rms) = 20\log 1.259 = 2$  (dB)

CTCSS block (AVDD=VDD=5V, Ta=+25°C)

Parameter	Min.	Typ.	Max.	Unit
<b>RX mode</b>				
Zero crossing threshold (mVrms) (note : 1*)		20		mV
Data Duty Ratio	30	50	70	%
<b>TX mode</b>				
CTCSS tone (form Tone 2) to VTX3, for 600Ω		-12		dBm
CTCSS tone to MTX, for 600Ω		-22		dBm
<b>Filter</b>				
<b>BPF for Audio</b>				
Pass-Band Frequency	300		3400	Hz
Pass-Band Ripple			1.0	dB
<b>LPF for Sub-Audio</b>				
Pass-Band Frequency	60		253	Hz
Pass-Band Ripple			1.0	dB
Output (min. output loading impedance for max. output swing)				
Output loading impedance for AURX pin (VRF = VDD/2)		200		kΩ
Output loading impedance for MTX pin (VRF = VDD/2)		51		kΩ
Output loading impedance for AURX pin (VRF = 2.5V/2)		82		kΩ
Output loading impedance for MTX pin (VRF = 2.5V/2)		27		kΩ

Note :

1\*. Test under Fig.26 application circuit. Zero crossing threshold means ZC's transition level in Fig.14 CTCSS block. This level is close but not equal to CTCSS receiving sensitivity. The CTCSS receiving sensitivity partially depends on user software judgement. Also CTCSS receiving sensitivity can be adjusted by changing external resistors of RX AMP in Fig.26 application circuit.

## XII. Timing Diagrams

### AC Test Input/Output Waveform

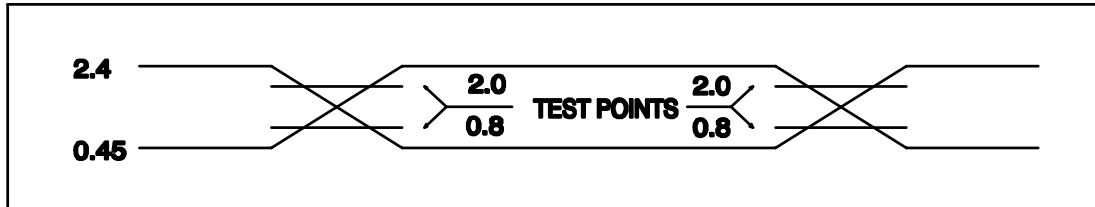

AC Testing: Input are driven at 2.4V for logic "1", and 0.45V for logic "0". Timing measurements are made at 2.0V for logic "1", and 0.8V for logic "0".

### RESET Timing

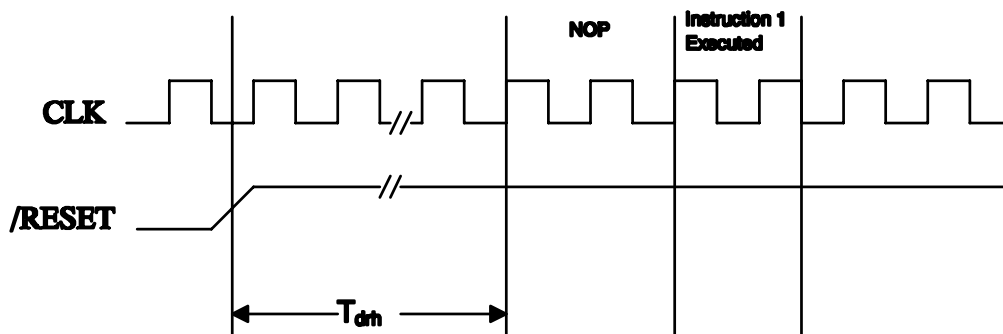

### TCC Input Timing

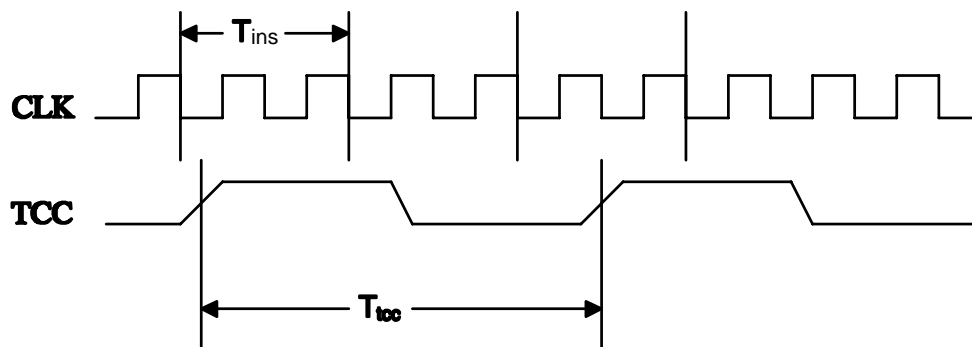

Fig.24 AC timing

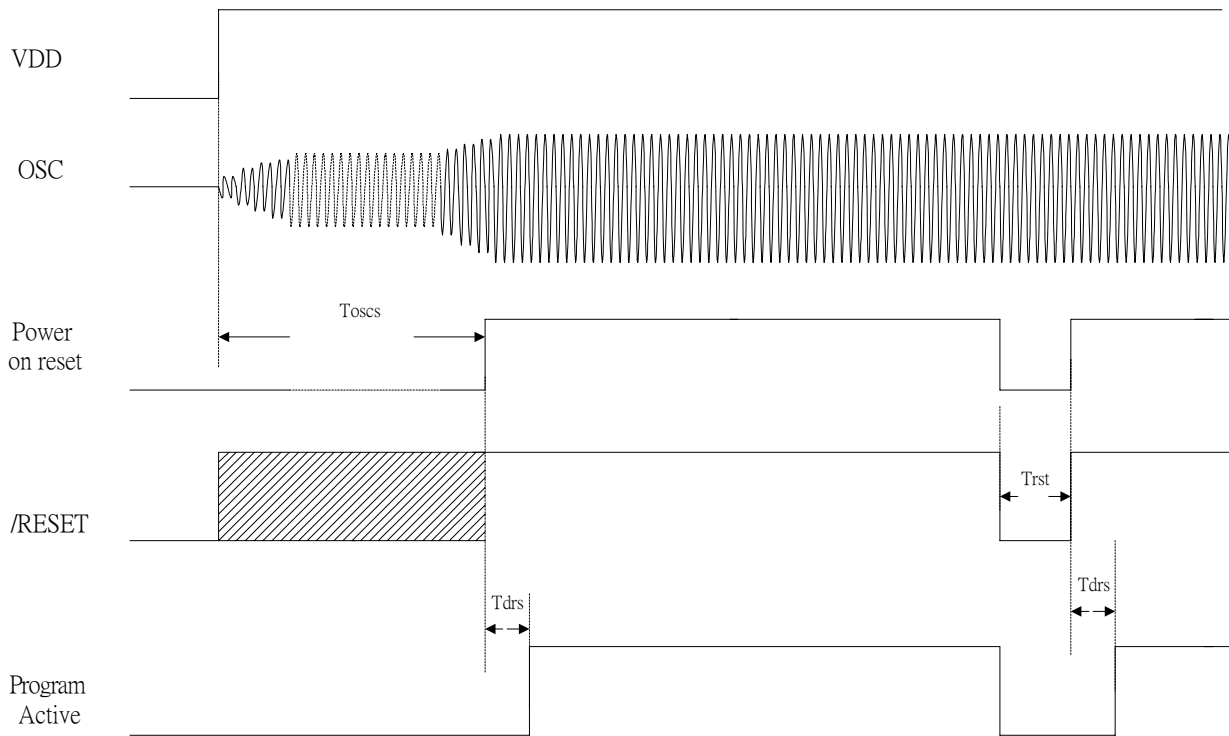

Fig.25 OSC and reset timing

### XIII. Application circuits

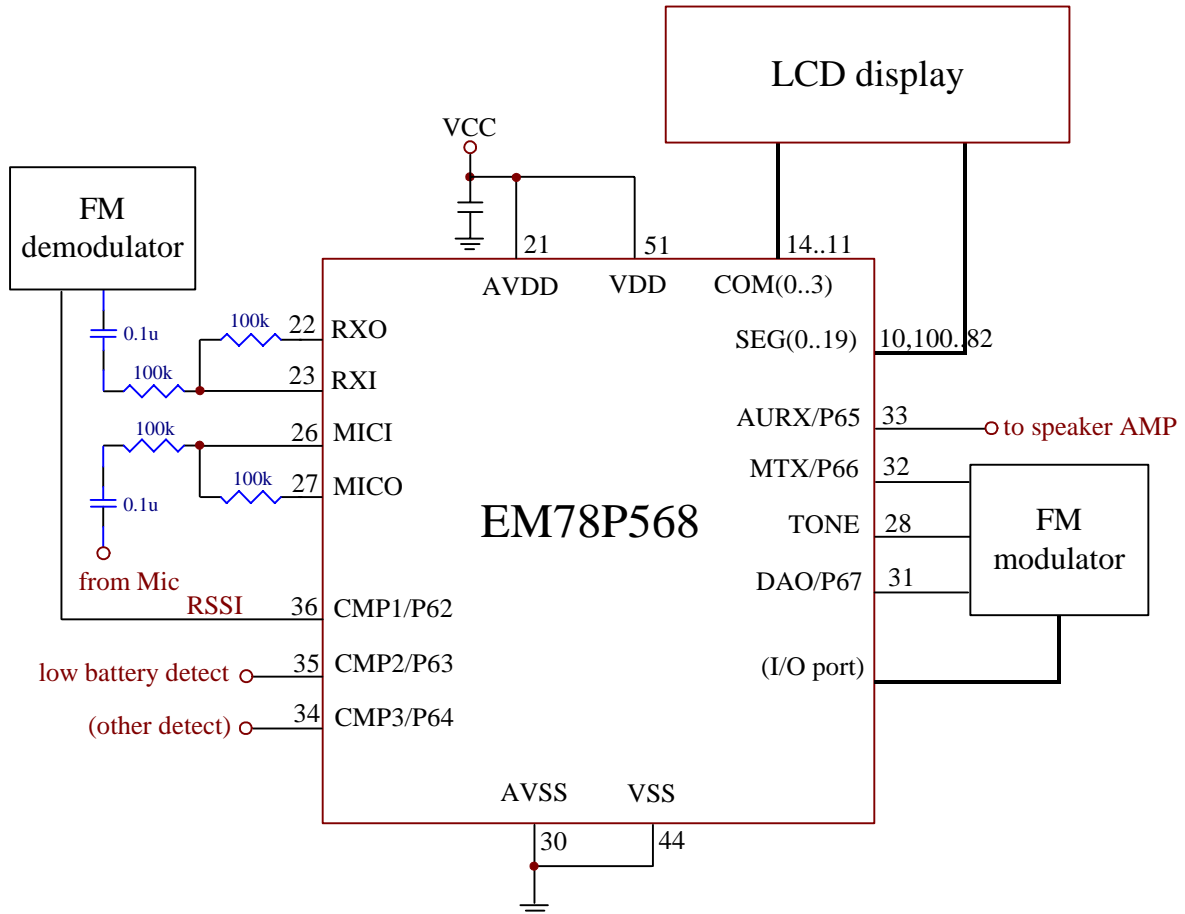
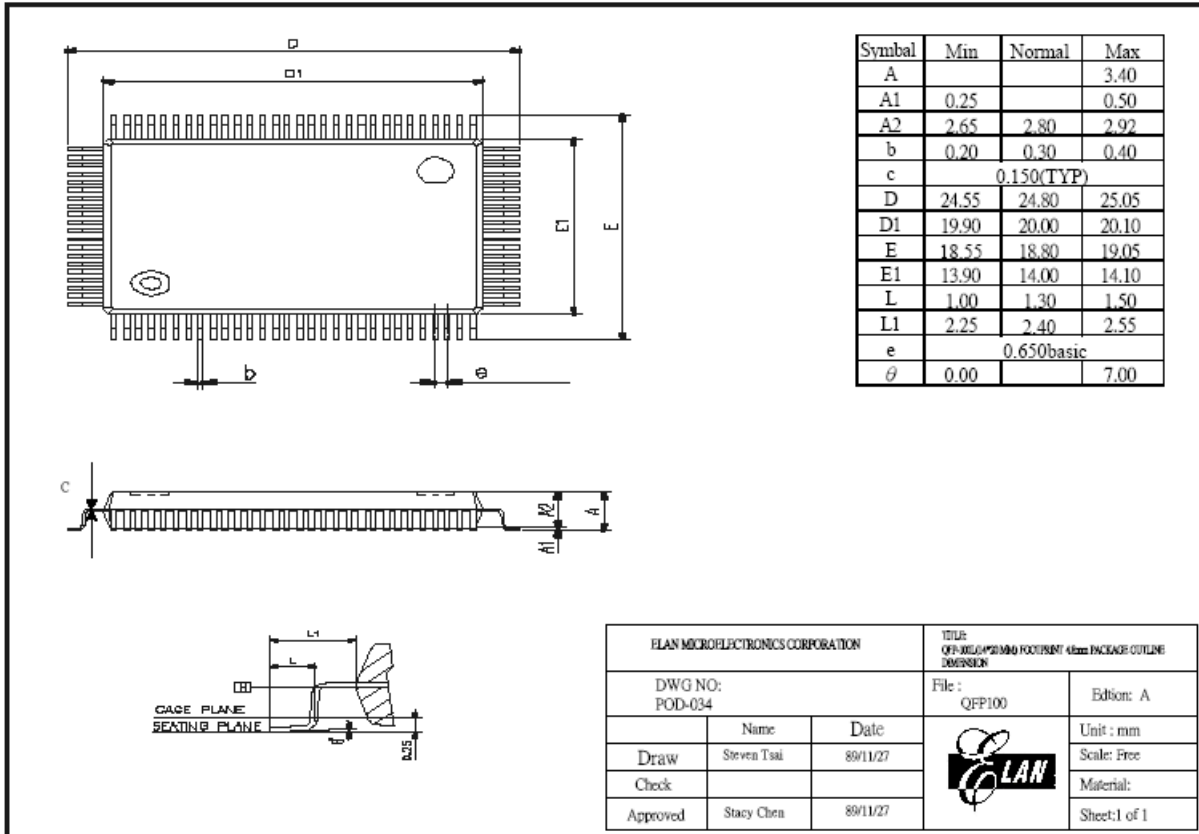

Fig.26 Application circuit for FRS

Appendix. Package outline dimension



QFP-100 dimension

\* This specification are subject to be changed without notice.

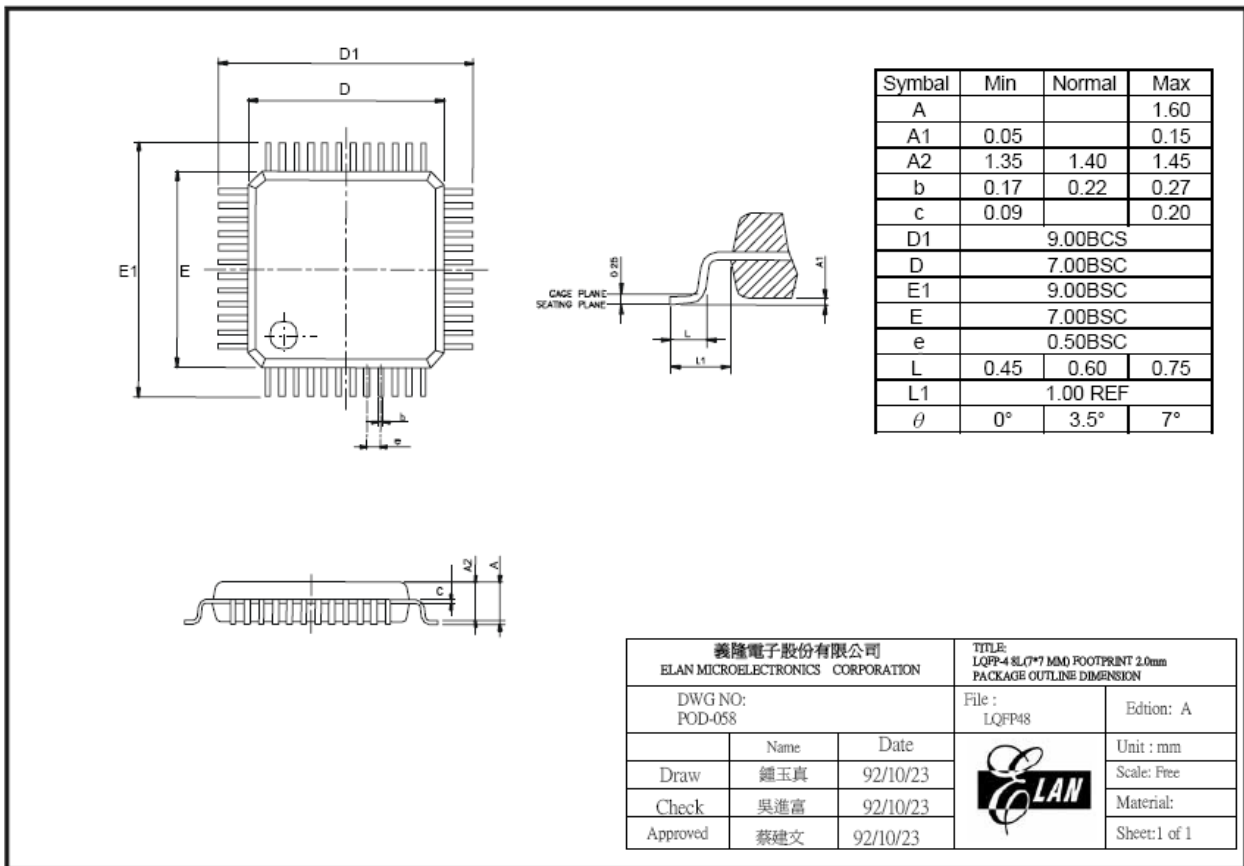

LQFP-48 dimension