



Patent Number : 38715, 95661 (R.O.C)

Patent Pending : 84200836 (R.O.C)

GENERAL DESCRIPTION

The EM83701 Mouse Controller is specially designed to control mouse device. This single chip can interface three key-switches and four photo-couple direct to RS-232C. The EM83701 does not need any external power supply,so the mouse can go without a power line. It is versatile with both microsoft and mouse system.

Debouncing circuit were provided to prevent false entry and to improve the accuracy. In 1200 baud rate non-auto speed with 200 DPI wheels and photo-couples, the scanning is 650 mm/sec without missing a dot in microsoft mode,and the scanning speed can up to 770 mm/sec in mouse system mode.

Using the auto-speed adjusting circuits, EM83701 promotes the power of the mouse in movement. If the mouse moves at low speed, it will be very smooth. While at high speed, EM83701 series can change the scanning ability of the motion and detects more dots than at low speed. It is said that horizotal and vertical counters acquire different dots in the same distance according to different speed.

FEATURES

- Built-in two zener diode between V_{DD} and V_{SS} , RTS and V_{DD} .
- Auto speed with dynamic resolutions.
- Buit-in noise immunity circuit.
- CMOS DIP 16 pins package & SOP 16 pins package.
- Low power dissipation.
- Use 32.768 kHz crystal.
- Oscillator circuits on-chip.
- Serial output in 1200 baud rate.
- Can be powered directly from RS-232C.
- Can drive directly to RS-232C.
- Three key-switches and four photo-couples inputs.
- Both key-in and key-release debounce interval 13 ms.
- Through three key-switches input, EM83701 can exert seven different output.
- The sampling rate of motion detector is 65 KHz.

APPLICATIONS

- Optical mouse or pen-mouse
- Mechanical mouse or pen-mouse
- Optomechanical mouse or pen-mouse
- Mechanical track ball
- Optomechanical track ball



PIN ASSIGNMENTS

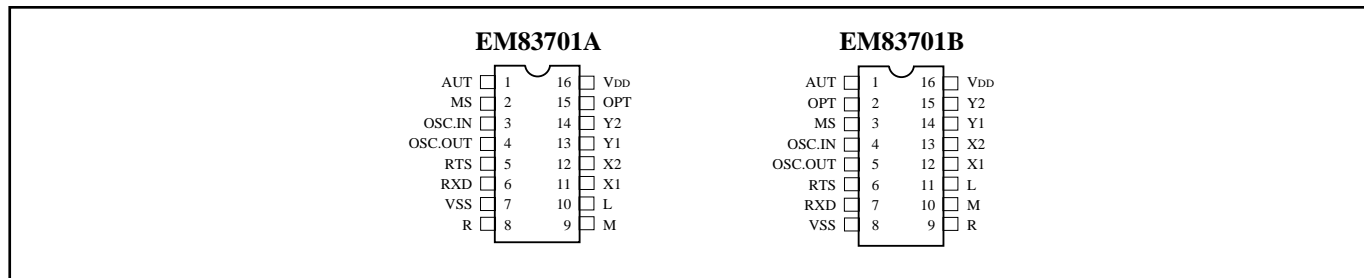

FUNCTIONAL BLOCK DIAGRAM

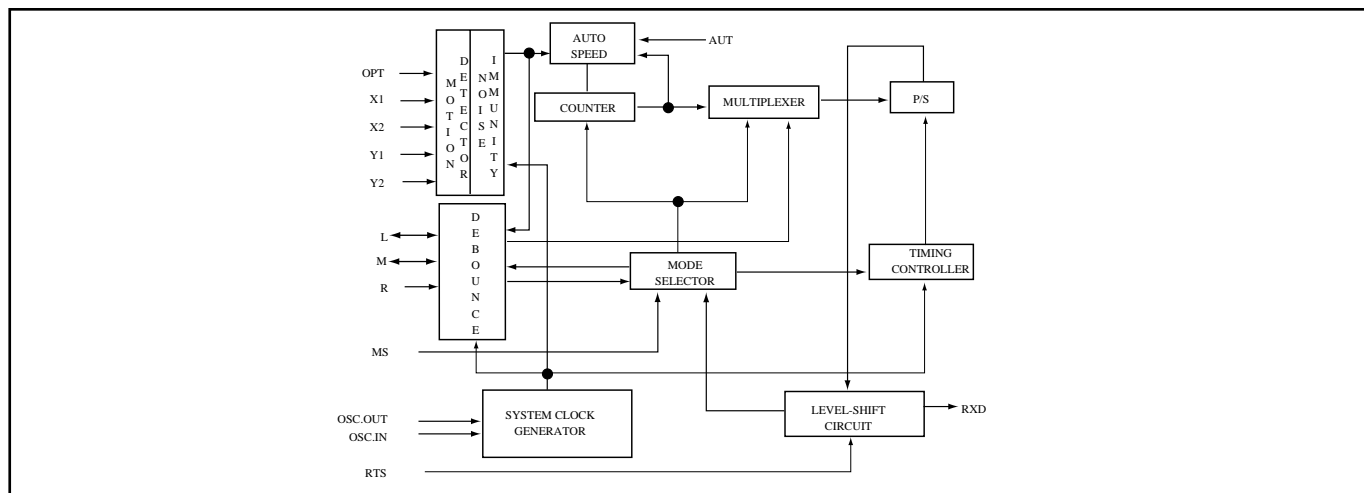

PIN DESCRIPTIONS

Symbol	I/O	Function
AUT	I	If AUT is switched to high level, EM83701 is selected on AUTOSPEED mode. The built-in auto speed control circuit will adjust resolution according to the velocity of the mouse. There are three pseudo DPI (100 DPI, 200 DPI, 400 DPI) in EM83701. EM83701 is in non-auto speed mode with 200 DPI resolution, while AUT is connected to low level or floating.
MS	I	When this pin is connected to V _{DD} , then EM83701 is assigned to operate under the microsoft mode only. If the pin is connected to V _{SS} , then EM83701 will operate under the mouse system mode. However if this pin is "floating", then EM83701 is on the "power on initiation" situation and if any one of three buttons is chosen, thence EM83701 will operate under the mouse mode. And while the whole system is on "power on initiation". No key is chosen then operation will be under microsoft mode.
OSC.IN OSC.OUT	I	A built-in inverter provides oscillation with 32.768 KHz crystal. Several counters used to decrease the frequency of oscillation and create 1200 baud rate, key-switches debounce and photo-couple sensor scanning clock, etc.
RTS	I	Positive power input. The signal is sent by mouse driver from computer to the mouse to select a mode. During the reset time, EM83701 echoes the selected mode to the RXD line after the reset pulse signal of the RTS line. RXD will send out CD(H) code if it is under the microsoft mode. RXD will send out two byte C8(H) code if it is under the mouse system mode in EM83701.

* This specification are subject to be changed without notice.



Symbol	I/O	Function
RXD	O	There are 8 or 7 bits in each data byte. Using parallel-in and serial-out components, the data bytes are shifted out from bit 0 through the high bits. EM83701 will transmit the data while the status of three keyswitches or the state of the horizontal counter or vertical counter is changed.
V _{SS}		Negative power input.
R M L	I I/O I/O	Three key-switches exert seven different combinations totally. Both key-pressed and key-released signals will be sent accompanied with horizontal and vertical state. The status of the key-switches will be preserved, whenever the value of horizontal or vertical counters will present at RXD. And the debounce interval for both key-press and key-release is 13 ms. In testing mode, L and M are the outputs of motion detector. Using R key can select the two outputs X1, X2 or Y1, Y2. This feature can help manufacturer to adjust the phase of four photo-couples for improving the yield.
X1 X2	I	Four photo-couple signals denote UP, DOWN, LEFT and RIGHT state. If EM83701 is in 1200 baud rate on non-auto speed mode, the system provides 40 transmission cycles per second in microsoft mode to the utmost. In mouse system mode, the cycles are 24 maximum. During the scanning period, as long as the photo-couples change their states, the value of vertical or horizontal counter will increase or decrease accordingly.
OPT	I	Whenever OPT is connected to V _{DD} , the chip will enter testing mode.
V _{DD}		Power.

FUNCTION DESCRIPTIONS

A) Operating Mode

Mouse system mode

Anytime the mouse changes its state, including the key-switches and the photo-couple sensors, EM83701 will detect the result and transmit to RS-232C. Mouse system transmits the result with five bytes in 1200 baud rate. Each byte contains 10 bits, one start bit, one stop bit and eight data bits. The first byte represents the key-switches status. The second byte denote the number counted by the horizontal counter. The third byte conveys the number accumulated by the vertical counter. If the mouse is moved faster, the photo-couple sensors detect the "change state" and output the record, excessive horizontal counter will be transported through the fourth byte, and vertical counter through the fifth byte. Otherwise, the fourth and fifth byte are zero.

Output bytes arrange:

bit no	7	6	5	4	3	2	1	0
1st byte.....	1	0	0	0	0	L'	M'	R'*
2nd byte.....	H7	H6	H5	H4	H3	H2	H1	H0
3rd byte.....	V7	V6	V5	V4	V3	V2	V1	V0
4th byte.....	H7	H6	H5	H4	H3	H2	H1	H0
5th byte.....	V7	V6	V5	V4	V3	V2	V1	V0

* ' denotes complement



(B) Microsoft mode

In microsoft mode, the transmission cycle consists of three bytes. Each byte is divided into one start bit, seven data bits and two stop bit. The first byte contains “L”, “R” switch status and four bits of the two most significant bits in horizontal counter and vertical counter. The next byte represents the value accumulated by horizontal counter, the last byte is the data of the vertical counter. Notice that “M” key-switch is not active in the microsoft mode and the vertical data is transmitted in 2’s complement.

Output byte arrange:

bit	no	6	5	4	3	2	1	0
1st	byte.....	1	L	R	V7'	V6'	H7	H6
2nd	byte.....	0	H5	H4	H3	H2	H1	H0
3rd	byte.....	0	V5'	V4'	V3'	V2'	V1'	V0'

(C) Testing mode

Whenever OPT is connected to V_{DD} , the chip will enter buyer’s testing mode. The X direction output signals of comparators will present to L and M pin. Pressing “R” key can toggle the output from X direction to Y direction.

(D) Echo mode

RXD will send out CD(H) code when RTS rise from low to high under microsoft mode. Under mouse system mode, when RTS rise from low to high, the RXD pin EM83701 will send out two byte C8(H) code.



ABSOLUTE MAXIMUM RATINGS

Parameter		Min.	Max.	Unit
Supply voltage	$V_{DD}-V_{SS}$	-0.3	7.0	V
	$RTS-V_{SS}$	-0.3	14	V
Temperature under bias		0	70	°C
Storage temperature range		-65	150	°C
Power dissipation		-	500	mW

DC ELECTRICAL CHARACTERISTICS ($T_A=25^{\circ}C$ to $70^{\circ}C$)

Parameter	Sym.	Min.	Typ.	Max.	Unit.
Operating voltage	V_{DD}	-	-	6.5	V
	V_{RTS}	-	-	13	V
Operating current ($V_{DD}=5.4V, RTS=V_{DD}$, no load)	I_{op}	-	-	0.6	mA
Operating current ($V_{DD}=6.2V, RTS=V_{DD}$, no load)	I_{op}	3	-	-	mA
RTS operating current ($V_{DD}=5.6V, RTS=11V$)	I_{RTS}	-	-	0.6	mA
RTS operating current ($V_{DD}=5.6V, RTS=11.8V$)	I_{RTS}	3	-	-	mA
RXD high output voltage ($V_{rh}=V_{rts}-2.6V$)	I_{rh}	2.0	-	-	mA
RXD low output voltage ($V_{rl}=V_{ss}+2.6V$)	I_{rl}	-	-	-2.0	mA
X1,X2,Y1,Y2 low input voltage	V_{pl}	-	-	0.7	V
X1,X2,Y1,Y2 high input voltage	V_{ph}	1.3	-	-	V
X1,X2,Y1,Y2 input current (pull low resistor $V_{ds}=1.0V$)	I_{pi}	57	-	104	μA
RTS high input voltage	V_{t+}	9.6	-	-	V
RTS low input voltage	V_{t-}	-	-	6.8	V
Low input voltage , other pins	V_{ail}	-	-	1.5	V
High input voltage , other pins	V_{aih}	3.5	-	-	V
AUT,L,M,R,OPT input current (pull low resistor $V_{ds}=5.6V$)	I_{mi}	18.6	-	56	μA
AUT,OSC.IN,L,M,R,X1, X2,Y1,Y2,OPT input leakage current ($V_{in} = 0V$)	I_{il}	0	-	1.0	μA
OSC.IN input leakage current ($V_{in} = 5.6V$)	I_{ih}	-1.0	-	0	μA

- * All voltages in above table are compared with V_{SS} .
- * All parameters in above table are tested under $V_{DD}=5.6V$.

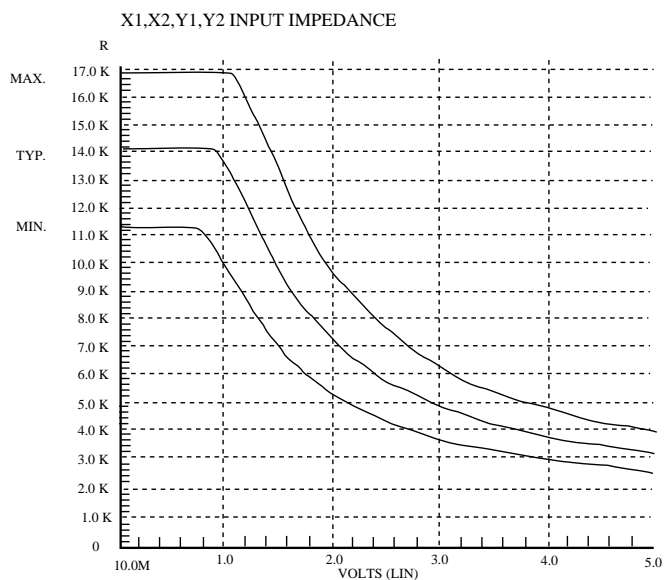

AC ELECTRICAL CHARACTERISTICS ($T_A=0^{\circ}C$ to $70^{\circ}C$)

Parameters	Sym.	Min.	Typ.	Max.	Unit
Oscillating frequency	Fosc	32768±200ppm			Hz
Key debounce	Tkd	-	13	-	ms
Transmission time mouse (1200)	Tms	-	41.1	-	ms
Transmission time microsoft (1200)	Tmx	-	24.7	-	ms
Start bit time (1200)	Ts	-	0.85	-	ms
Data bit time (1200)	Td	-	0.82	-	ms
Stop bit time (1200)	Tp	-	0.82	-	ms
Mode code delay time (1200)	Trd	11.9	-	14	ms
Rising edge crossed width Fosc=32.768KHz	Tr	15	-	-	us
Rising edge crossed width Fosc=32.768KHz	Tr	15	-	-	us

AC TIMING TEST POINT :

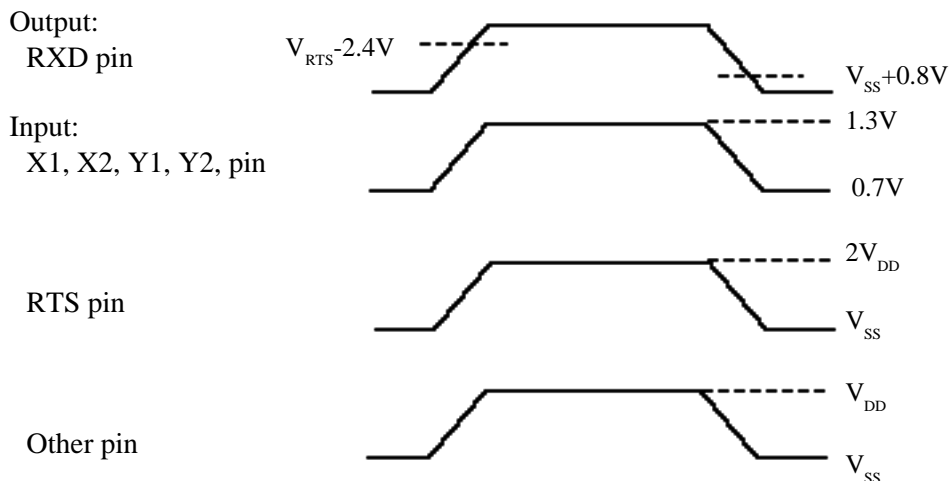

* This specification are subject to be changed without notice.



TIMING DIAGRAM

(A) P/S output:
Key in/release

Mouse RXD

Microsoft RXD

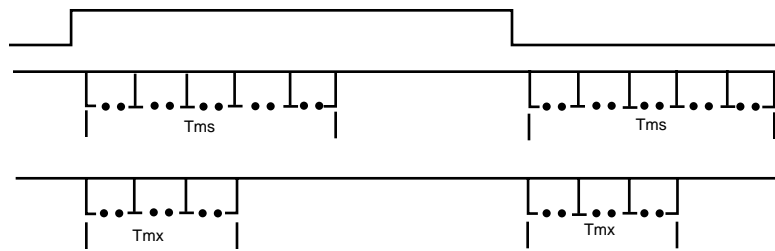

(B) Bytes structure:
Mouse RXD

Microsoft RXD

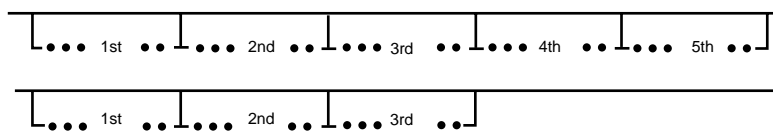

(C) Bits structure:
(1) Mouse

RXD LINE
Data bit no.

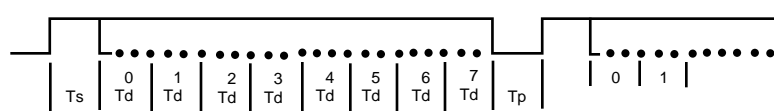

(2) Microsoft
RXD LINE
Data bit no.

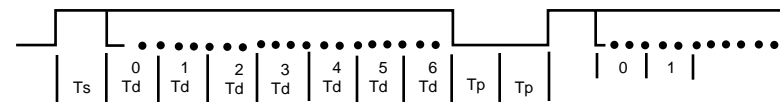

#(D) mode select timing:
(1) Mouse system

RTS

RXD

Reset code
"C8" Bit no.

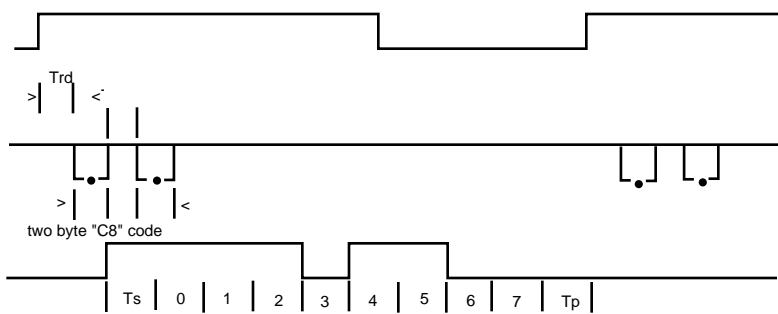

(2) Microsoft
RTS

RXD

Reset code
"CD" Bit no.

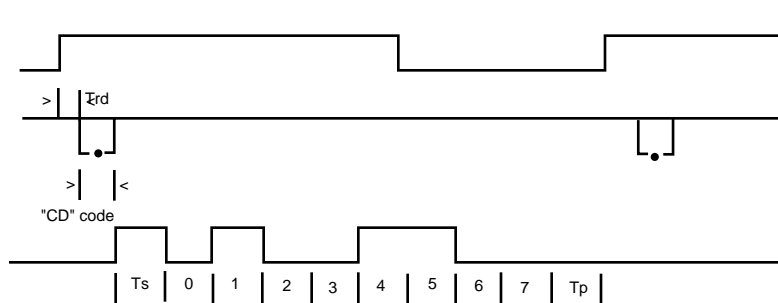



#(E) Photo-couples pulse width

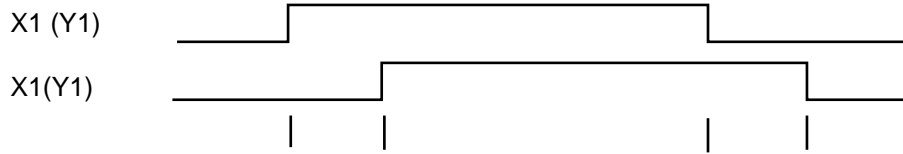

EM83701 I/O pin equivalent circuit:

AUT, HB, R, M, L, OPT:

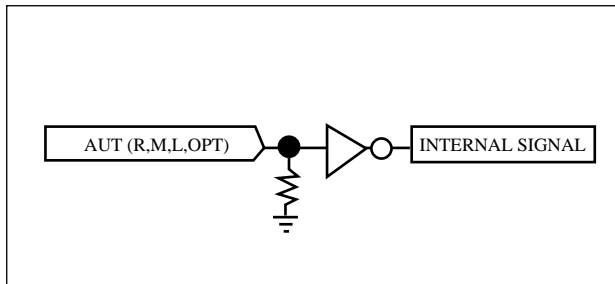

OSC.IN, OSC.OUT:

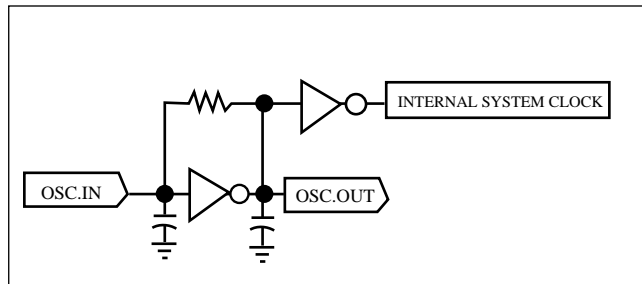

L, M, R, MS:

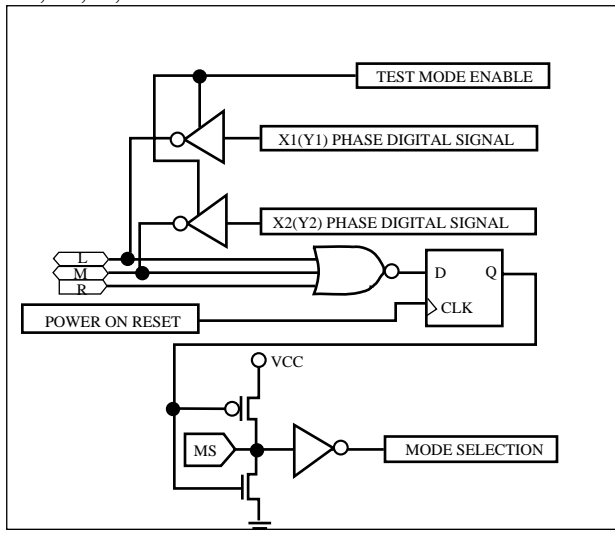

RTS, RXD:

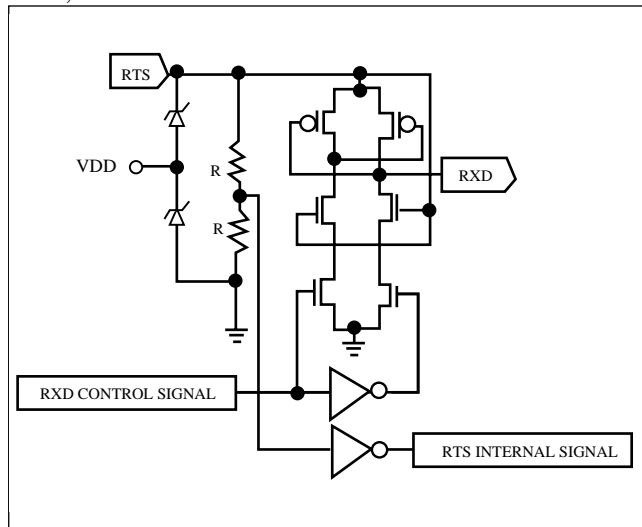

X1, X2, Y1, Y2:

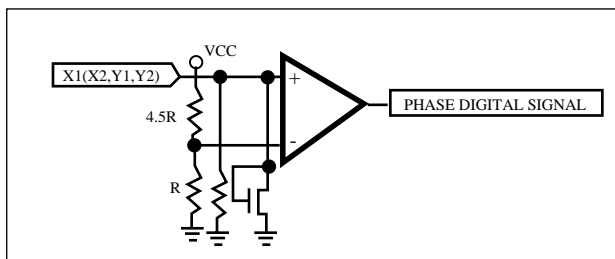



APPLICATION CIRCUIT

Mechanical Mouse

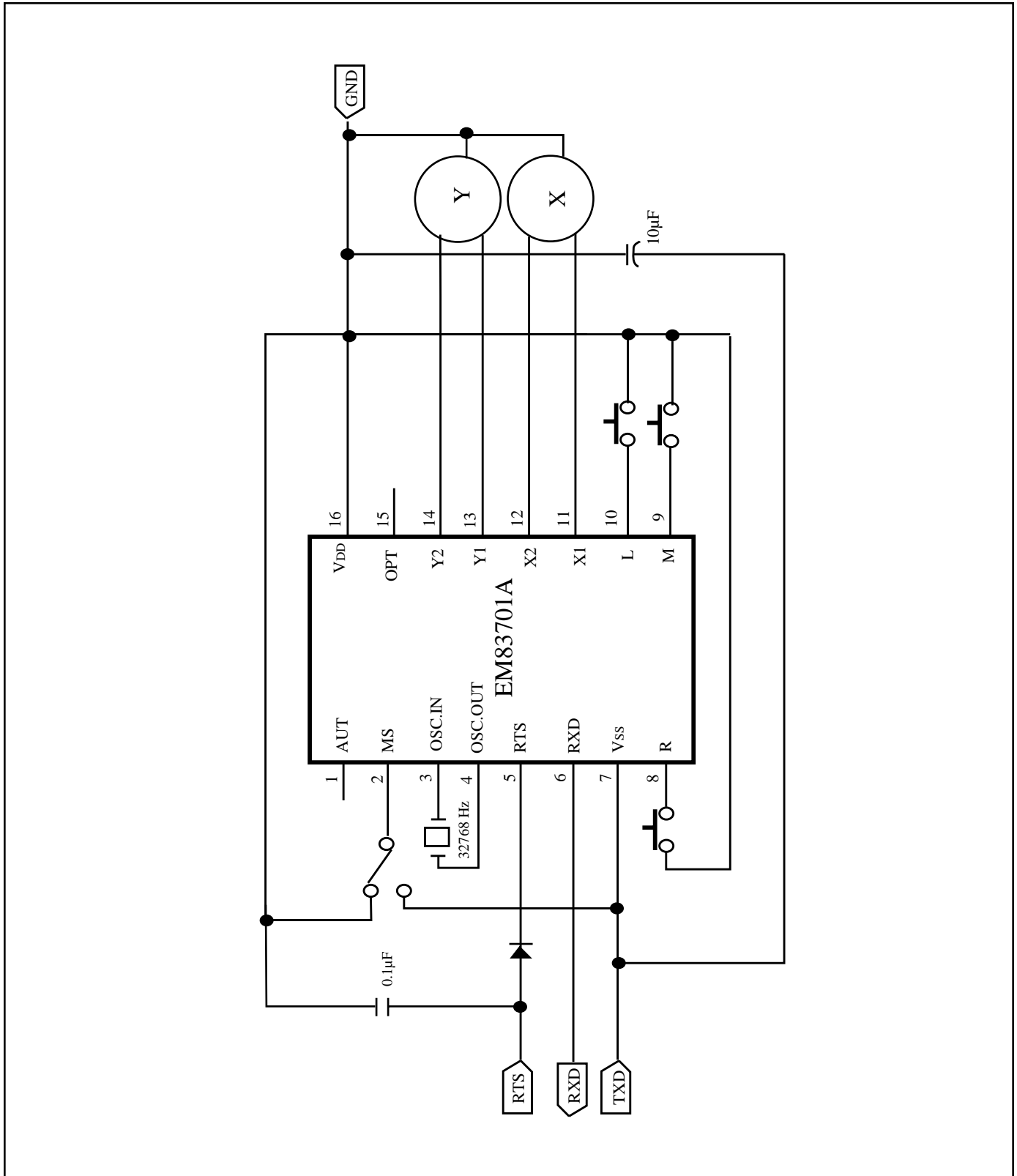



Optomechanical Mouse

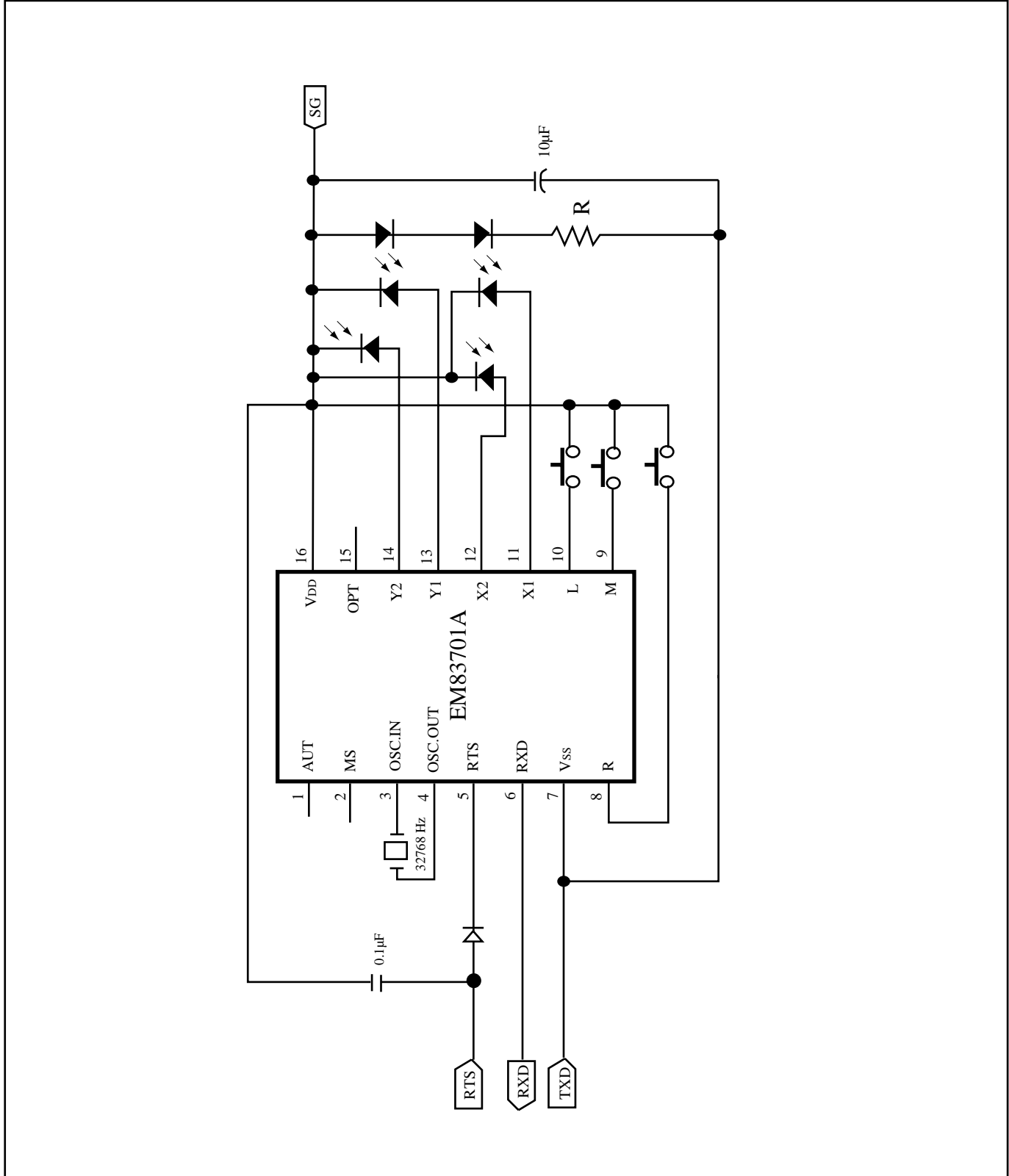

* This specification are subject to be changed without notice.



Optomechanical Mouse

