

1.2W Fully Differential Audio Power Amplifier with Shutdown Select

General Description

The EMA1003 is a fully differential audio power amplifier primarily designed for demanding applications in mobile phones and other portable communication device applications. It is capable of delivering 1.2 watt of continuous average power to an 8Ω BTL load with less than 1% distortion (THD+N) from a 5VDC power supply.

The EMA1003 does not require output coupling capacitors or bootstrap capacitors, and therefore is ideally suited for mobile phone and other low voltage applications where minimal power consumption is a primary requirement.

The EMA1003 features a low-power consumption shutdown mode. To facilitate this, shutdown may be enabled by either logic high or low depending on mode selection. Driving the shutdown mode pin either high or low enables the shutdown select pin to be driven in a likewise manner to enable Shutdown. Additionally, the EMA1003 features an internal thermal shutdown protection mechanism.

The EMA1003 contains advanced pop & click circuitry which eliminates noises which would otherwise occur during turn-on and turn-off transitions.

The EMA1003 is unity-gain stable and can be configured by external gain-setting resistors.

Key Specifications

• Improved PSRR at 217Hz	70dB(typ)
• Power Output at 5.0V, 8Ω & 1% THD	1.2W(typ)
• Power Output at 2.6V, 8Ω & 1% THD	300mW(typ)
• Shutdown current	0.1μA (typ)

Features

- Fully differential amplification
- Available packages MSOP
- Ultra low current shutdown mode
- Can drive capacitive loads up to 500 pF
- Improved pop & click circuitry eliminates noises during turn-on and turn-off transitions
- 2.2 - 5.5V operation
- No output coupling capacitors, snubber networks or bootstrap capacitors required
- Unity-gain stable
- External gain configuration capability
- Shutdown high or low selectivity
- High CMRR

Applications

- Mobile phones
- PDAs
- Portable electronic devices

Connection Diagram

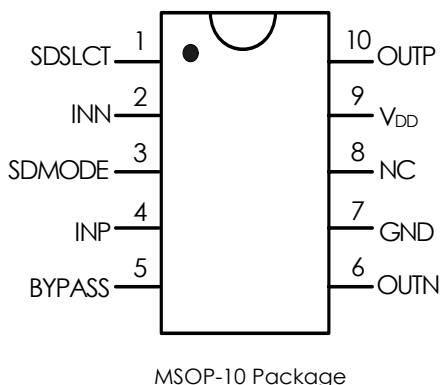

Order information

EMA1003-50MA10GRR/NRR

50	5.0V Operation
MA10	MSOP-10 Package
GRR	RoHS(Pb free)
	Rating: -40 to 85°C
	Package in Tape & Reel
NRR	RoHS & Halogen free (By Request)
	Rating: -40 to 85°C
	Package in Tape & Reel

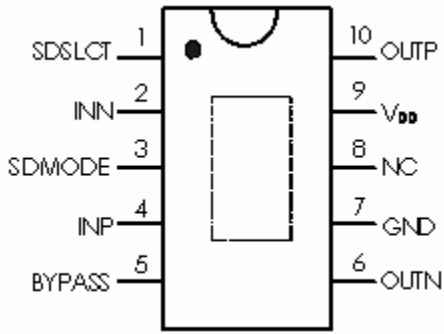

MSOP-10FD (Exposed Pad)Package

EMA1003-50ME10GRR

- 50 5.0V Operation
- ME10 MSOP-10FD (Exposed Pad)Package
- GRR RoHS(Pb free)
- Commercial Grade Temperature Rating: -40 to 85°C
- Package in Tape & Reel
- NRR RoHS & Halogen free (By Request)

Order, Mark & Packing Information

Package	Marking	Product ID	Packing
MSOP-10		EMA1003-50MA10GRR	3K units Tape & Reel
MSOP-10FD (Exposed Pad)		By request	3K units Tape & Reel

Typical Application

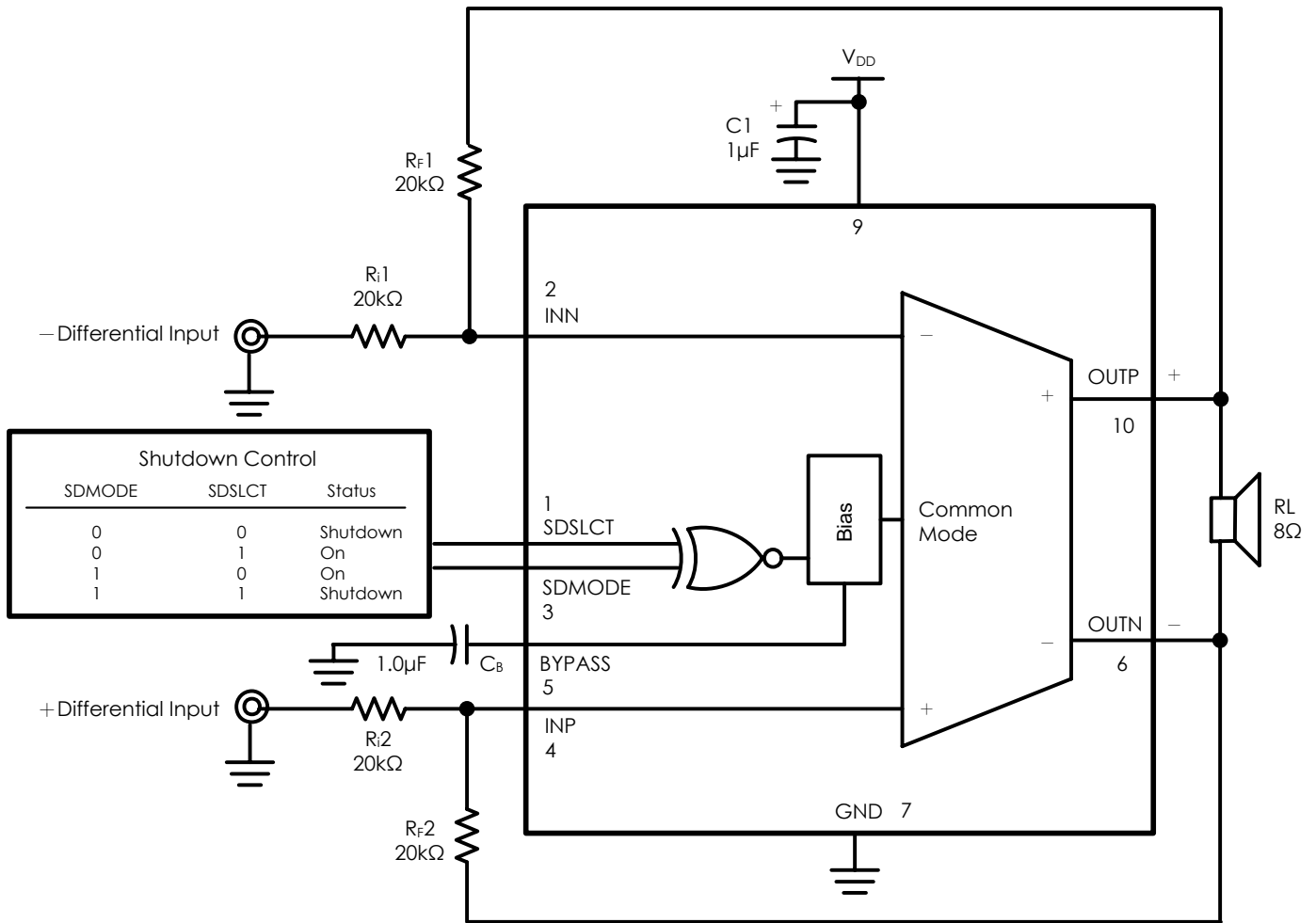

FIGURE 1. Typical Audio Amplifier Application Circuit

Absolute Maximum Ratings

Supply Voltage	6.0V	Thermal Resistance	
Storage Temperature	-65°C to +150°C	θ_{JA} (MSOP)	190°C/W
Input Voltage	-0.3V to VDD +0.3V	Operating Ratings	
Power Dissipation	Internally Limited	Temperature Range	-40°C \leq TA \leq 85°C
ESD Susceptibility	HBM 2KV MM 200V	Supply Voltage	2.2V \leq VDD \leq 5.5V
Junction Temperature	150°C		

Electrical Characteristics V_{DD} = 5V

The following specifications apply for V_{DD} = 5V, A_V = 1 and R_L = 8Ω unless otherwise specified. Limits apply for T_A = 25°C.

Symbol	Parameter	Conditions	Conditions		Units (Limits)
			Typical	Limit	
I _{DD}	Quiescent Power Supply Current	V _{IN} = 0V, I _o = 0A	1.5	3	mA (max)
I _{SD}	Shutdown Current	V _{SDNB} =GND	0.1	1	μA (max)
P _O	Output Power	THD = 1 %(max), f = 1kHz R _L = 4Ω R _L = 8Ω	1.7 1.2	1.5 1	W (min)
THD+N	Total Harmonic Distortion + Noise	P _O = 0.8 Wrms ; f = 1kHz, 4Ω P _O = 0.4 Wrms ; f = 1kHz, 8Ω	0.008 0.008		%
PSRR	Power Supply Rejection Ratio	V _{ripple} = 200mV sine p-p f = 217Hz (Un-terminated input) f = 1kHz (Un-terminated input) f = 217Hz (10Ωterminated input) f = 1kHz (10Ωterminated input)	70 70 70 70		dB
CMRR	Common Mode Rejection Ratio	f = 217Hz	57		dB

Electrical Characteristics V_{DD} = 2.6V

The following specifications apply for V_{DD} = 2.6V, A_V = 1 and R_L = 8Ω unless otherwise specified. Limits apply for T_A = 25°C.

Symbol	Parameter	Conditions	Conditions		Units (Limits)
			Typical	Limit	
I _{DD}	Quiescent Power Supply Current	V _{IN} = 0V, I _o = 0A	1.3	2	mA (max)
I _{SD}	Shutdown Current	V _{SDNB} =GND	0.1	1	μA (max)
P _O	Output Power	THD = 1 %(max), f = 1kHz R _L = 4Ω R _L = 8Ω	0.45 0.3	0.4 0.28	W (min)
THD+N	Total Harmonic Distortion + Noise	P _O = 0.35 Wrms ; f = 1kHz, 4Ω P _O = 0.25 Wrms ; f = 1kHz, 8Ω	0.015 0.01		%
PSRR	Power Supply Rejection Ratio	V _{ripple} = 200mV sine p-p f = 217Hz (Un-terminated input) f = 1kHz (Un-terminated input) f = 217Hz (10Ωterminated input) f = 1kHz (10Ωterminated input)	70 70 60 60		dB
CMRR	Common Mode Rejection Ratio	f = 217Hz	55		dB

Typical Performance Characteristics

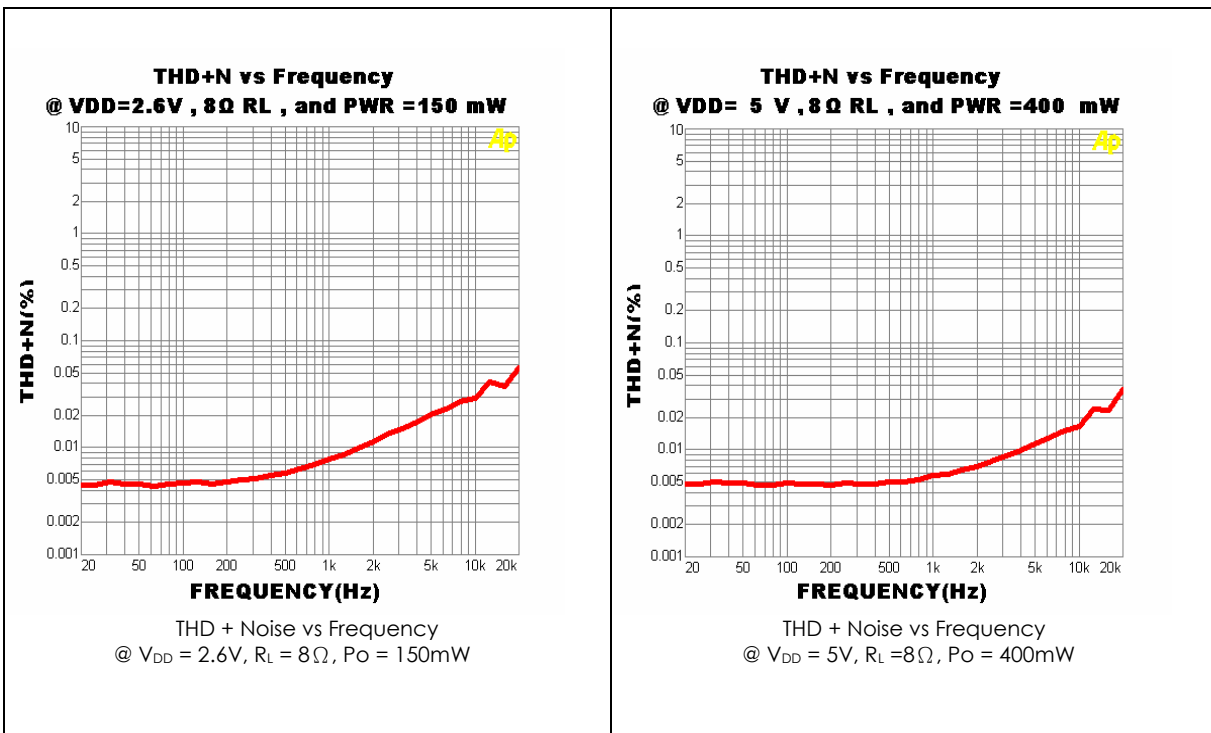
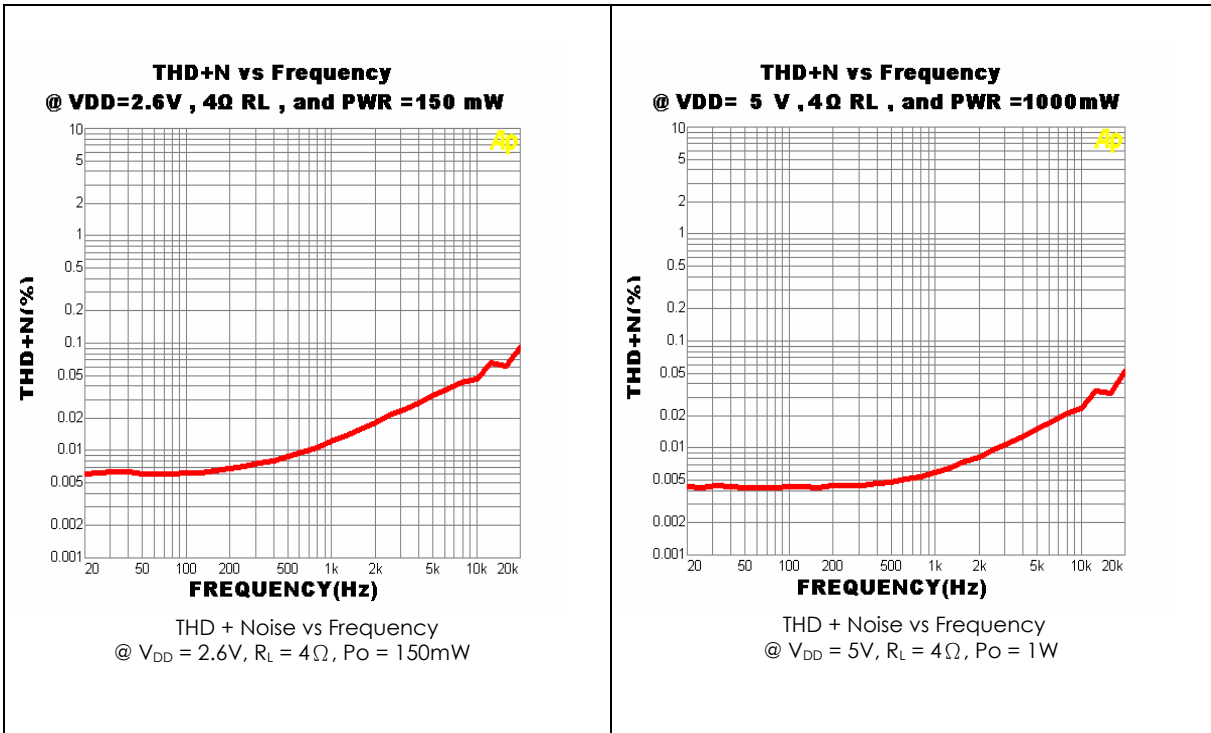

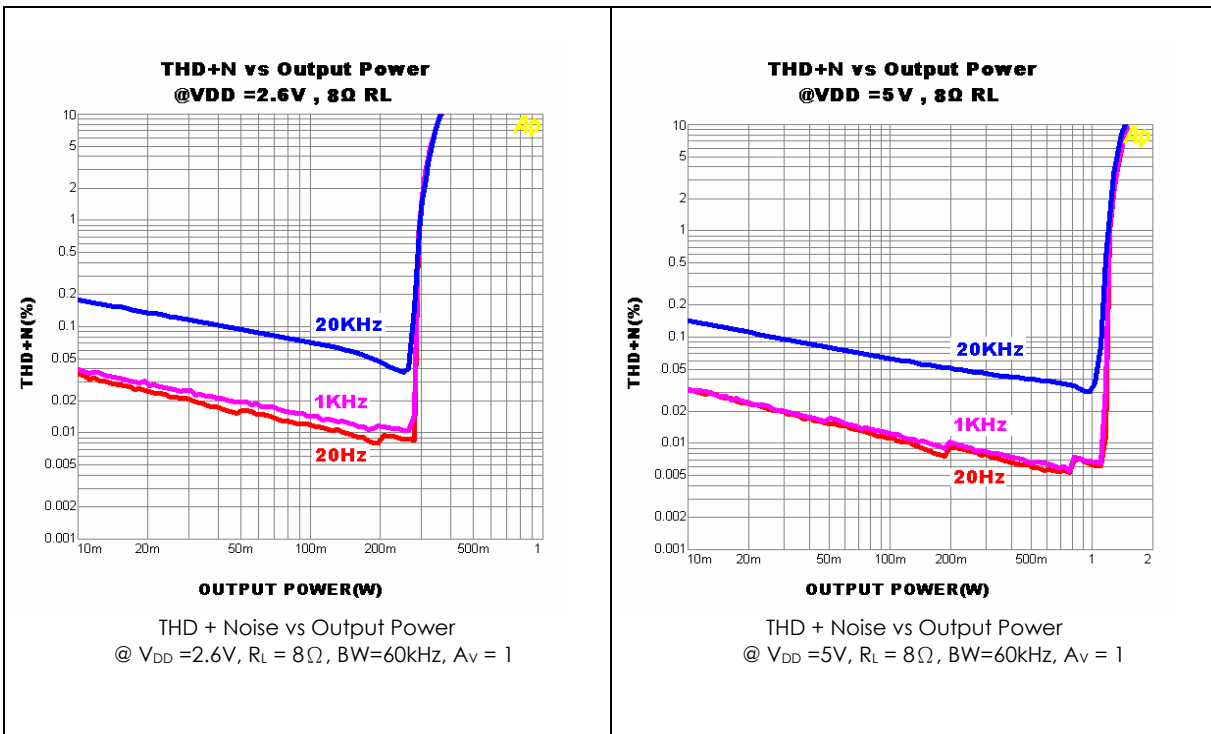
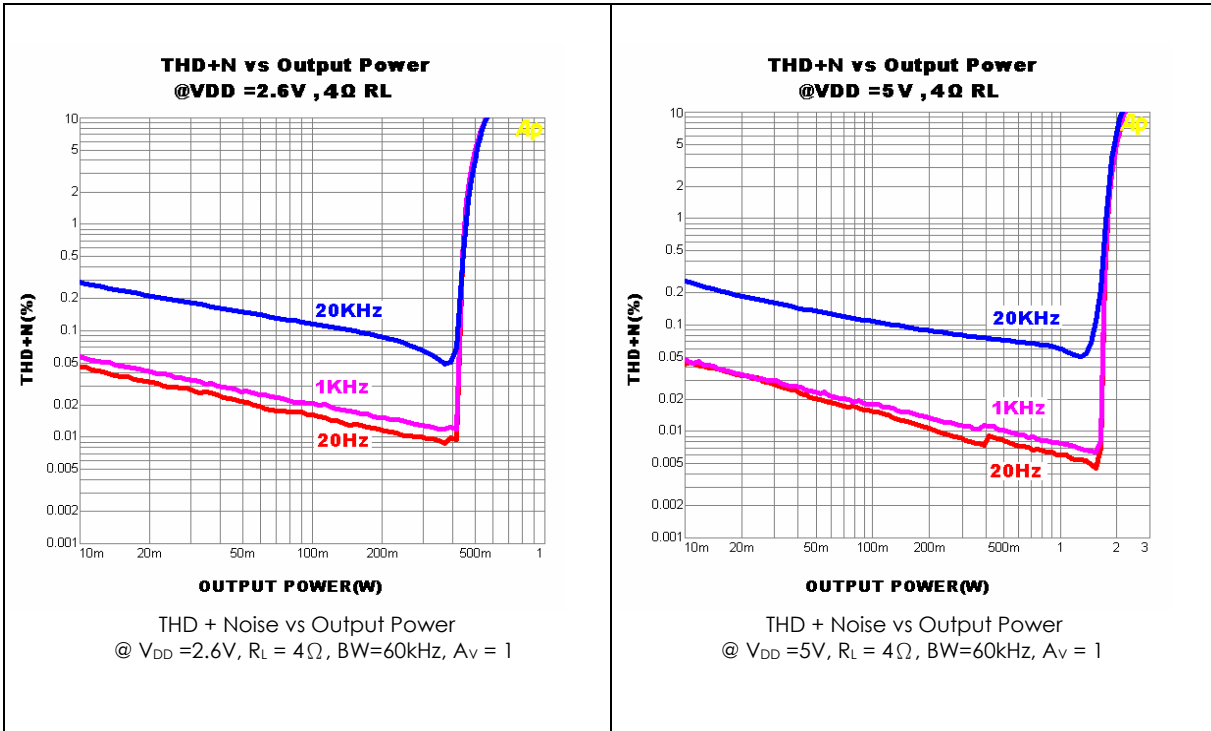

Power Supply Rejection Ratio (PSRR) VDD=3V

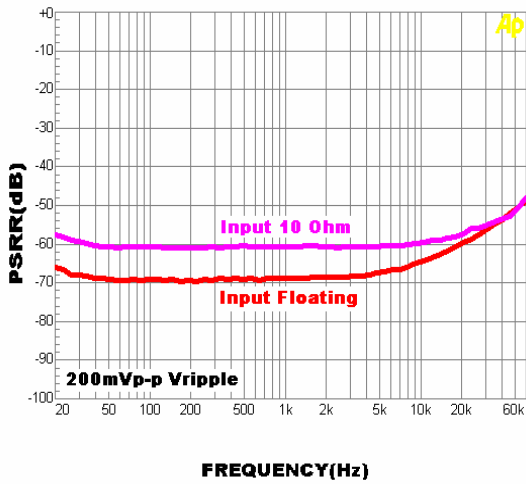

PSRR vs Frequency
@ $V_{DD} = 3V$, $R_L = 8\Omega$

Power Supply Rejection Ratio (PSRR) VDD=5V

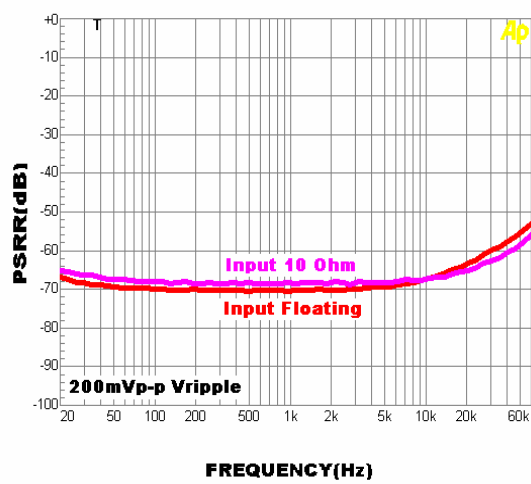

PSRR vs Frequency
@ $V_{DD} = 2.6V$, $R_L = 8\Omega$

Common Mode Rejection Ratio(CMRR) VDD=3V

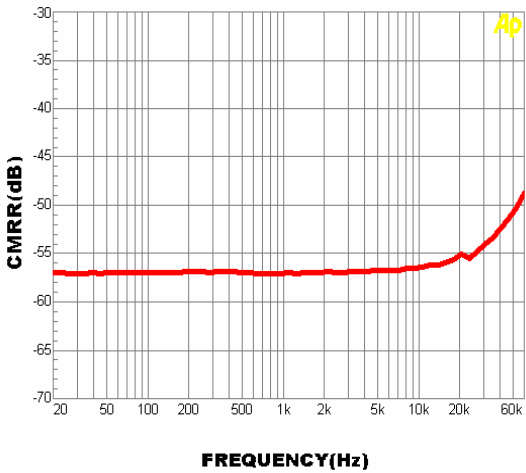

CMRR vs Frequency
@ $V_{DD} = 3V$

Common Mode Rejection Ratio(CMRR) VDD=5V

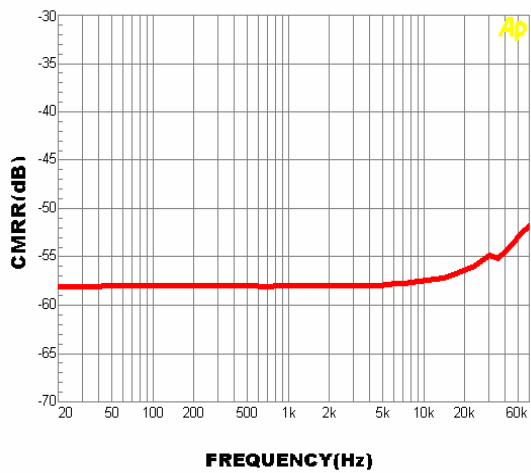

CMRR vs Frequency
@ $V_{DD} = 5V$

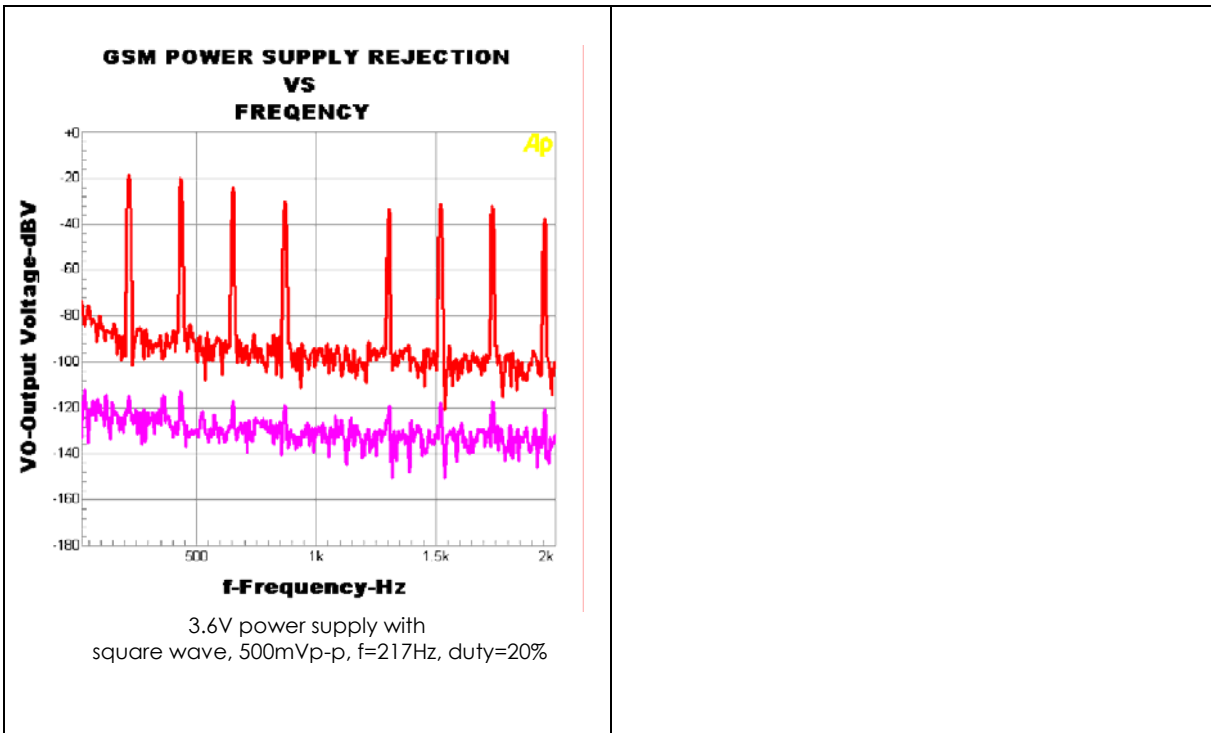

Physical Dimensions

MSOP-10

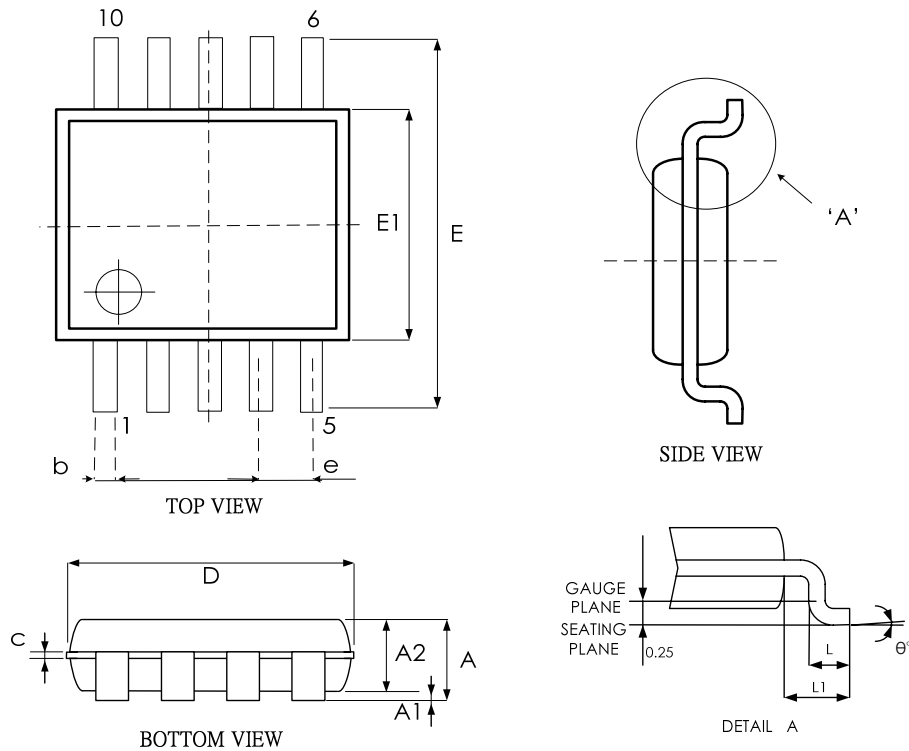

SYMBPLS	MIN.	NOM.	MAX.
A	—	—	1.10
A1	0.00	—	0.15
A2	0.75	0.85	0.95
b	0.17	—	0.27
c	0.08	—	0.23
D	3.00 BSC		
E	4.90 BSC		
E1	3.00 BSC		
e	0.50 BSC		
L	0.40	0.60	0.80
L1	0.95 BSC		
θ°	0.00	—	8.00

UNIT: MM

MSOP-10FD (Exposed Pad)

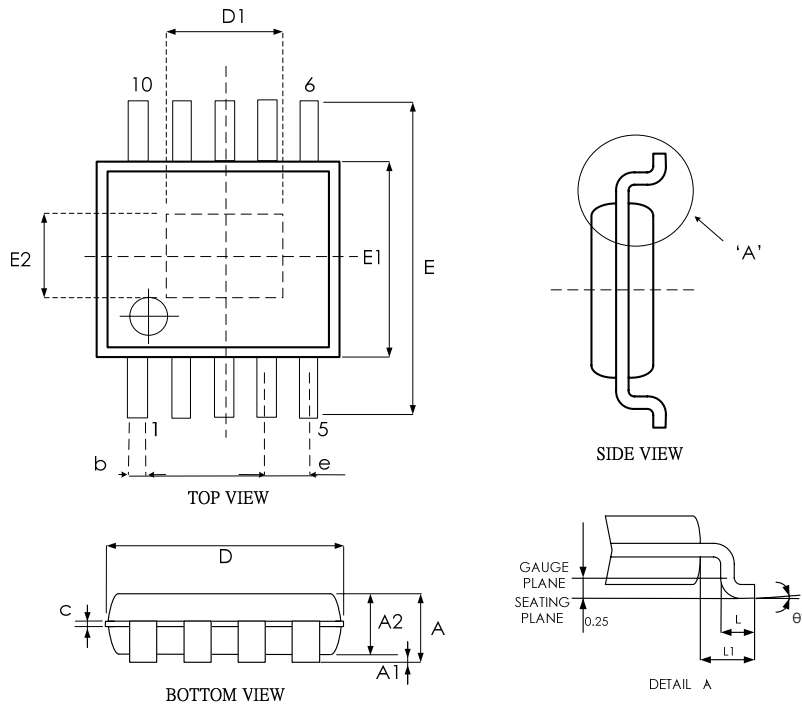

SYMBPLS	MIN.	NOM.	MAX.
A	—	—	1.10
A1	0.00	—	0.15
A2	0.75	0.85	0.95
b	0.17	—	0.27
c	0.08	—	0.23
D	3.00 BSC		
E	4.90 BSC		
E1	3.00 BSC		
e	0.50 BSC		
L	0.40	0.60	0.80
L1	0.95 BSC		
θ°	0.00	—	8.00

PAD SIZE	E2	D1
75X70E	1715 REF	1.600 REF

UNIT: MM

Revision History

Revision	Date	Description
2.0	2009.05.05	EMP transferred from version 1.1

Important Notice

All rights reserved.

No part of this document may be reproduced or duplicated in any form or by any means without the prior permission of ESMT.

The contents contained in this document are believed to be accurate at the time of publication. ESMT assumes no responsibility for any error in this document, and reserves the right to change the products or specification in this document without notice.

The information contained herein is presented only as a guide or examples for the application of our products. No responsibility is assumed by ESMT for any infringement of patents, copyrights, or other intellectual property rights of third parties which may result from its use. No license, either express, implied or otherwise, is granted under any patents, copyrights or other intellectual property rights of ESMT or others.

Any semiconductor devices may have inherently a certain rate of failure. To minimize risks associated with customer's application, adequate design and operating safeguards against injury, damage, or loss from such failure, should be provided by the customer when making application designs.

ESMT's products are not authorized for use in critical applications such as, but not limited to, life support devices or system, where failure or abnormal operation may directly affect human lives or cause physical injury or property damage. If products described here are to be used for such kinds of application, purchaser must do its own quality assurance testing appropriate to such applications.