

P-Channel Logic Level Enhancement Mode Field Effect Transistor

Product Summary:

$BV_{DSS}$	-30V
$R_{DS(on)}$ (MAX.)	14m $\Omega$
$I_D$	-12A

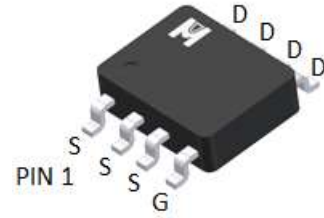
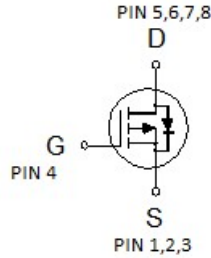

P Channel MOSFET

UIS, Rg 100% Tested

Pb-Free Lead Plating & Halogen Free



ABSOLUTE MAXIMUM RATINGS ( $T_A = 25\text{ }^\circ\text{C}$  Unless Otherwise Noted)

PARAMETERS/TEST CONDITIONS		SYMBOL	LIMITS	UNIT
Gate-Source Voltage		$V_{GS}$	$\pm 25$	V
Continuous Drain Current	$T_A = 25\text{ }^\circ\text{C}$	$I_D$	-12	A
	$T_A = 100\text{ }^\circ\text{C}$		-9	
Pulsed Drain Current <sup>1</sup>		$I_{DM}$	-48	
Avalanche Current		$I_{AS}$	-19	
Avalanche Energy	$L = 0.1\text{mH}$ , $I_{AS} = -19\text{A}$ , $R_G = 25\text{ }\Omega$	$E_{AS}$	90	mJ
Power Dissipation	$T_A = 25\text{ }^\circ\text{C}$	$P_D$	2.5	W
	$T_A = 100\text{ }^\circ\text{C}$		1	
Operating Junction & Storage Temperature Range		$T_j, T_{stg}$	-55 to 150	$^\circ\text{C}$

THERMAL RESISTANCE RATINGS

THERMAL RESISTANCE	SYMBOL	TYPICAL	MAXIMUM	UNIT
Junction-to-Case	$R_{\theta JC}$		25	$^\circ\text{C} / \text{W}$
Junction-to-Ambient <sup>3</sup>	$R_{\theta JA}$		50	

<sup>1</sup>Pulse width limited by maximum junction temperature.

<sup>2</sup>Duty cycle  $\leq 1\%$

<sup>3</sup>50 $^\circ\text{C} / \text{W}$  when mounted on a 1 in<sup>2</sup> pad of 2 oz copper.

ELECTRICAL CHARACTERISTICS ( $T_j = 25\text{ }^\circ\text{C}$ , Unless Otherwise Noted)



PARAMETER	SYMBOL	TEST CONDITIONS	LIMITS			UNIT
			MIN	TYP	MAX	
<b>STATIC</b>						
Drain-Source Breakdown Voltage	$V_{(BR)DSS}$	$V_{GS} = 0V, I_D = -250\mu A$	-30			V
Gate Threshold Voltage	$V_{GS(th)}$	$V_{DS} = V_{GS}, I_D = -250\mu A$	-1	-1.5	-3	
Gate-Body Leakage	$I_{GSS}$	$V_{DS} = 0V, V_{GS} = \pm 20V$			$\pm 100$	nA
		$V_{DS} = 0V, V_{GS} = \pm 25V$			$\pm 500$	
Zero Gate Voltage Drain Current	$I_{DSS}$	$V_{DS} = -24V, V_{GS} = 0V$			-1	$\mu A$
		$V_{DS} = -20V, V_{GS} = 0V, T_J = 125^\circ C$			-10	
On-State Drain Current <sup>1</sup>	$I_{D(ON)}$	$V_{DS} = -5V, V_{GS} = -10V$	-12			A
Drain-Source On-State Resistance <sup>1</sup>	$R_{DS(ON)}$	$V_{GS} = -10V, I_D = -12A$		12	14	m $\Omega$
		$V_{GS} = -4.5V, I_D = -9A$		17	21	
Forward Transconductance <sup>1</sup>	$g_{fs}$	$V_{DS} = -5V, I_D = -12A$		28		S
<b>DYNAMIC</b>						
Input Capacitance	$C_{iss}$	$V_{GS} = 0V, V_{DS} = -15V, f = 1MHz$		2270		pF
Output Capacitance	$C_{oss}$			342		
Reverse Transfer Capacitance	$C_{rss}$			300		
Gate Resistance	$R_g$	$V_{GS} = 15mV, V_{DS} = 0V, f = 1MHz$		3.7		$\Omega$
Total Gate Charge <sup>1,2</sup>	$Q_g(V_{GS}=-10V)$	$V_{DS} = -15V, V_{GS} = -10V, I_D = -10A$		39.3		nC
	$Q_g(V_{GS}=-4.5V)$			16		
Gate-Source Charge <sup>1,2</sup>	$Q_{gs}$			4.9		
Gate-Drain Charge <sup>1,2</sup>	$Q_{gd}$			7.5		
Turn-On Delay Time <sup>1,2</sup>	$t_{d(on)}$	$V_{DS} = -15V, I_D = -1A, V_{GS} = -10V, R_{GS} = 2.7\Omega$		20		nS
Rise Time <sup>1,2</sup>	$t_r$			12		
Turn-Off Delay Time <sup>1,2</sup>	$t_{d(off)}$			55		
Fall Time <sup>1,2</sup>	$t_f$			15		
<b>SOURCE-DRAIN DIODE RATINGS AND CHARACTERISTICS (<math>T_c = 25^\circ C</math>)</b>						
Continuous Current	$I_S$				-3.6	A
Pulsed Current <sup>3</sup>	$I_{SM}$				-14.4	
Forward Voltage <sup>1</sup>	$V_{SD}$	$I_F = I_S, V_{GS} = 0V$			-1.2	V
Reverse Recovery Time	$t_{rr}$	$I_F = I_S, dI_F/dt = 100A / \mu S$		52		nS
Reverse Recovery Charge	$Q_{rr}$			60		nC

<sup>1</sup>Pulse test : Pulse Width  $\leq 300 \mu sec$ , Duty Cycle  $\leq 2\%$ .

<sup>2</sup>Independent of operating temperature.

<sup>3</sup>Pulse width limited by maximum junction temperature.

EMC will review datasheet by quarter, and update new version.



TYPICAL CHARACTERISTICS

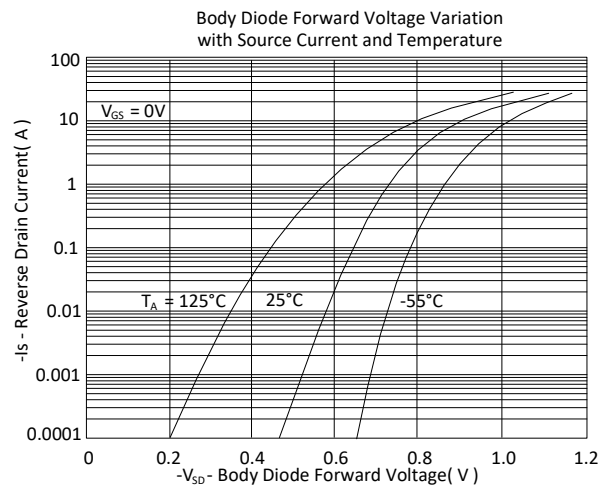
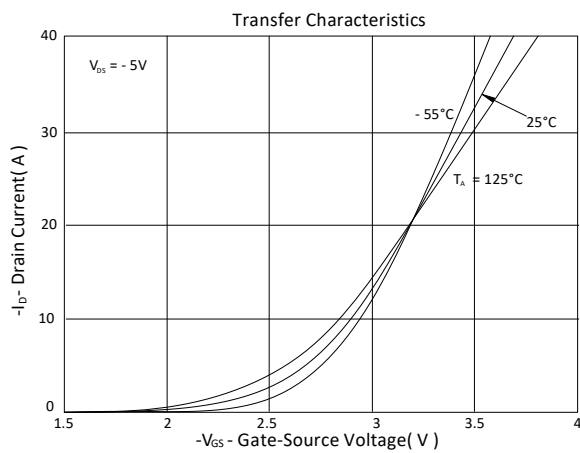
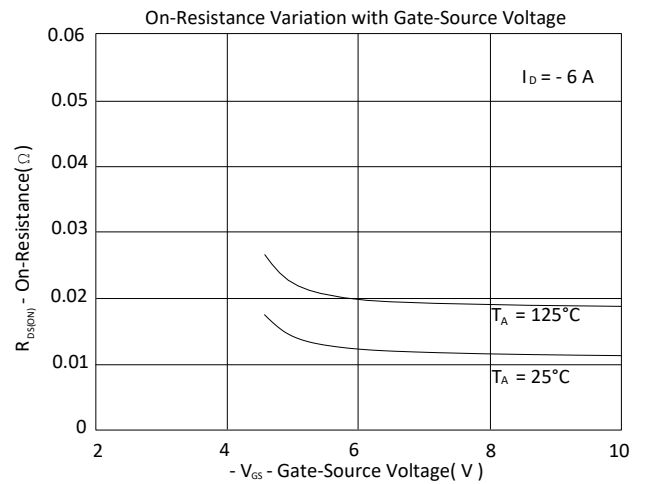
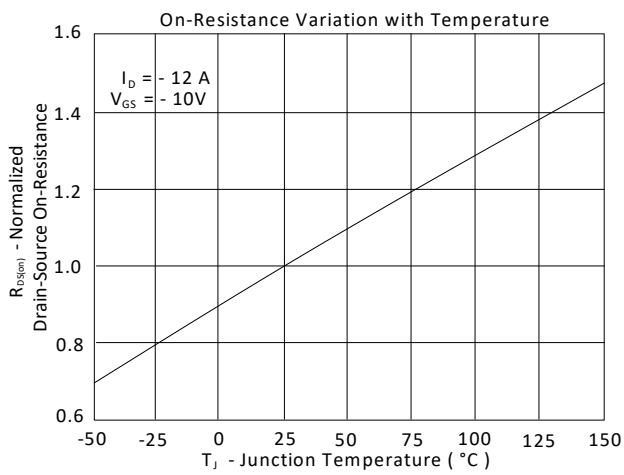
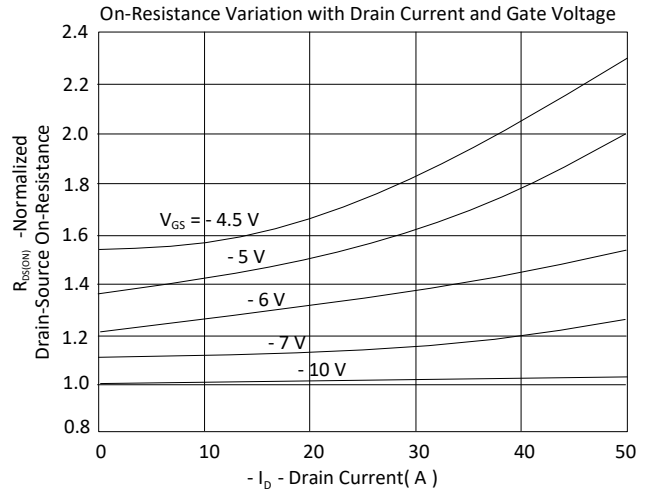
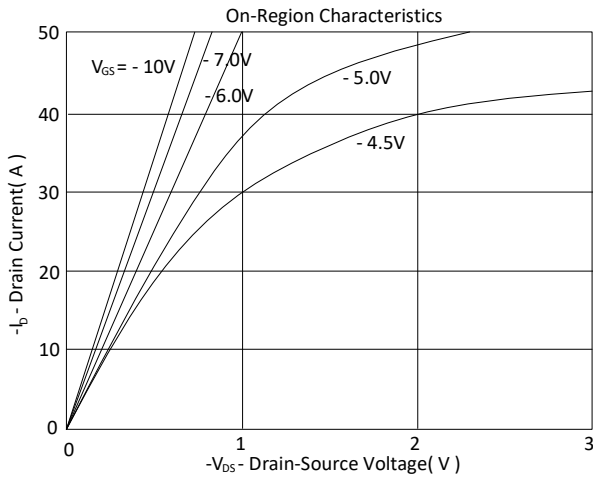

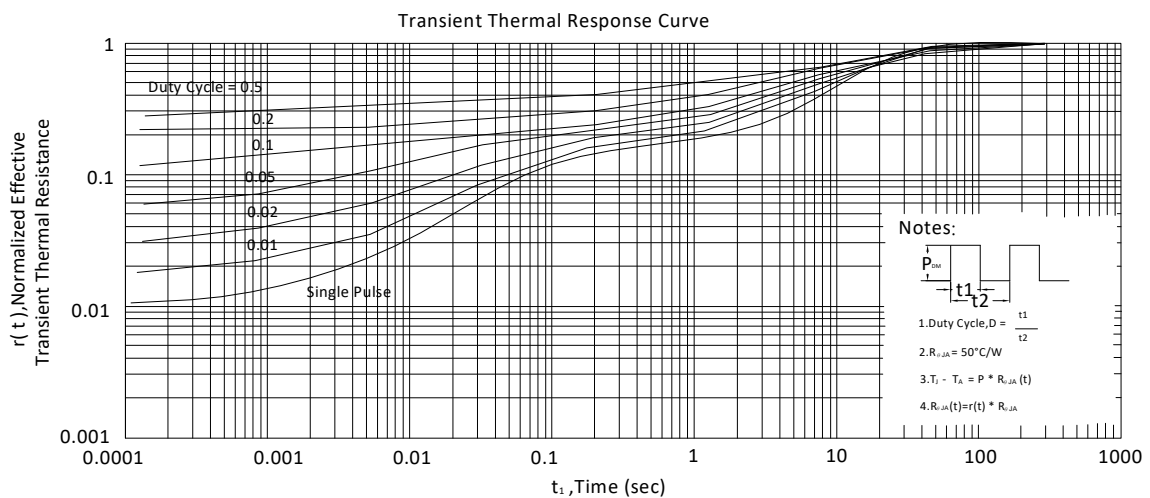
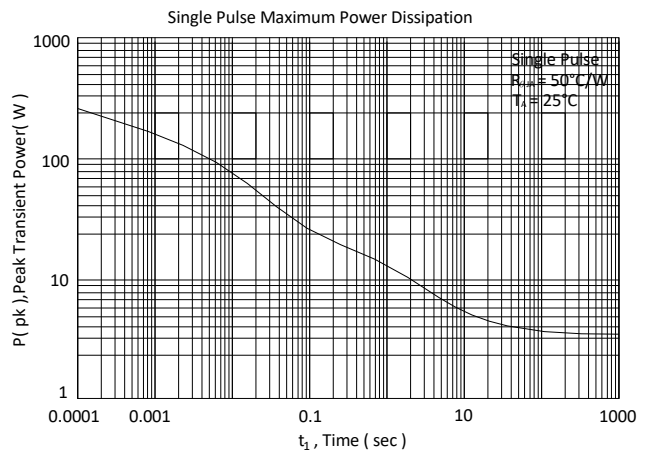
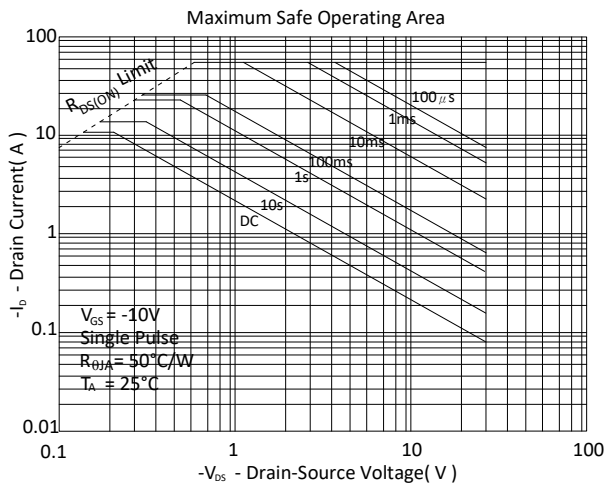
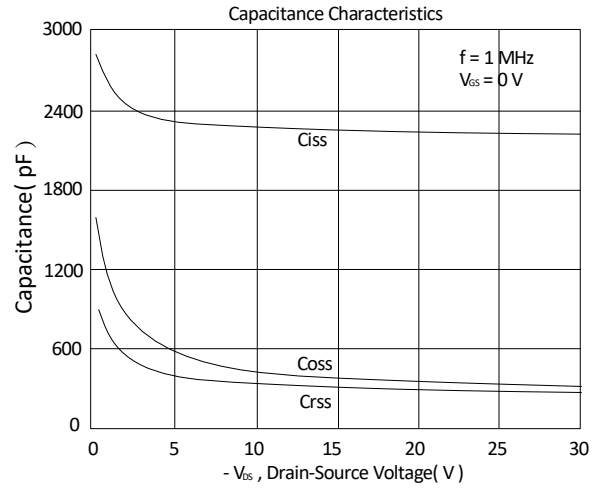
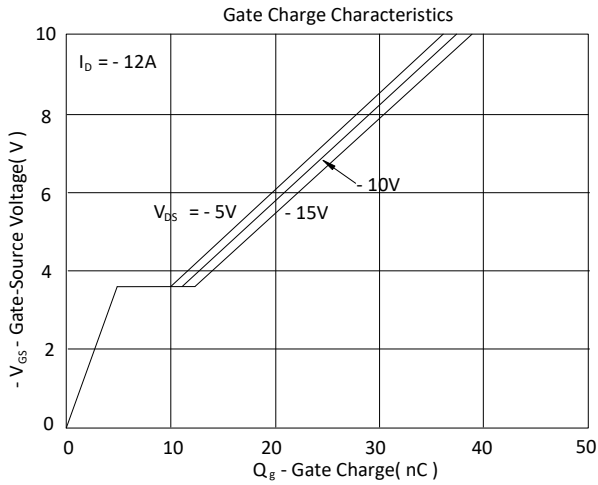

Ordering & Marking Information:

Device Name: EMB14P03G for SOP-8

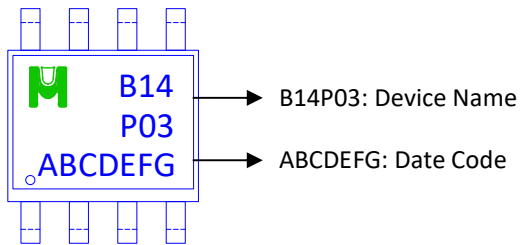

Outline Drawing

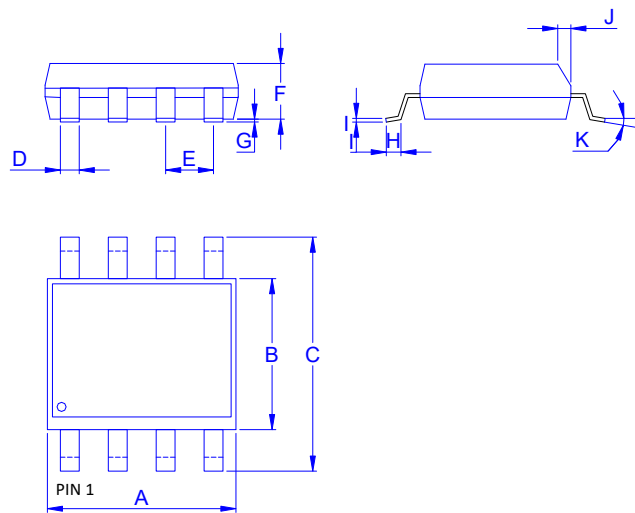

Dimension in mm

Dimension	A	B	C	D	E	F	G	H	I	J	K
Min.	4.70	3.80	5.80	0.31		1.35	0.01	0.40	0.10	0.25	0°
Typ.	4.90	3.90	6.00	0.41	1.27	1.55	0.18	0.60	0.20	0.30	
Max.	5.10	4.00	6.20	0.51		1.75	0.25	1.27	0.25	0.50	8°

Footprint

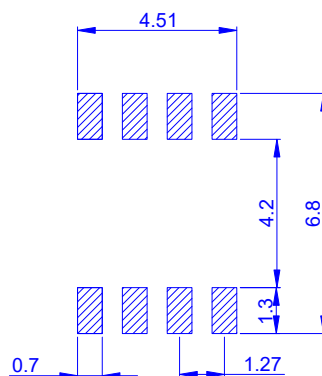



Tape&Reel Information:2500pcs/Reel

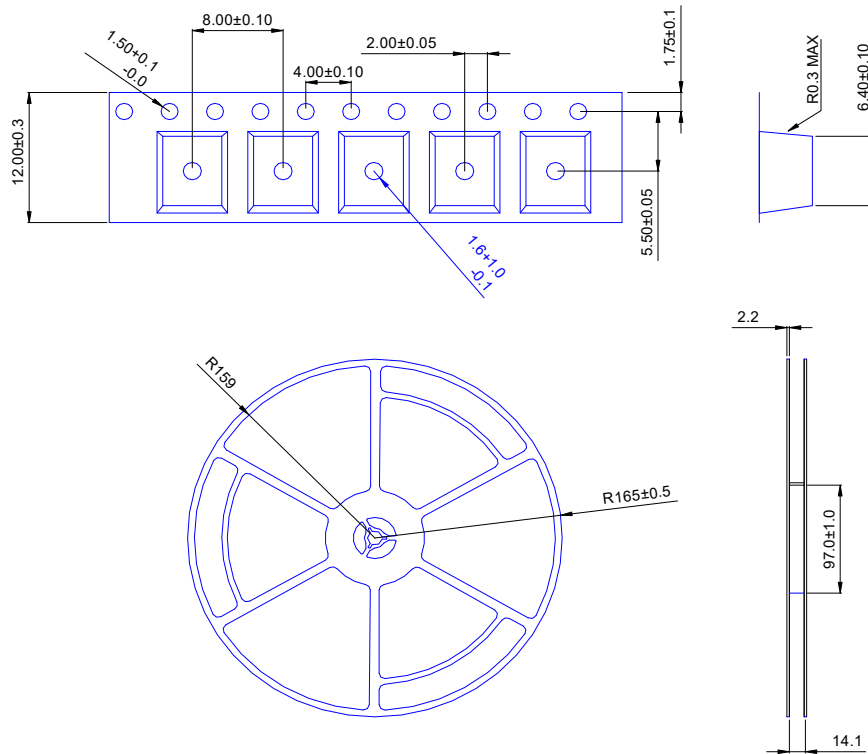

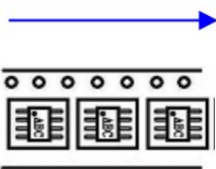
產品別	SOP-8
Reel 尺寸	13"
編帶方式	FEED DIRECTION 
前空格	25
後空格	50
裝箱數	
滿捲數量	2.5K
捲/內盒比	1 : 1
內盒滿箱數	2.5K
內/外箱比	10 : 1
外箱滿箱數	25K