

N-Channel Logic Level Enhancement Mode Field Effect Transistor

Product Summary:

BV_{DSS}	30V
$R_{DS(on)} (MAX.)$	22m Ω
I_D	6A

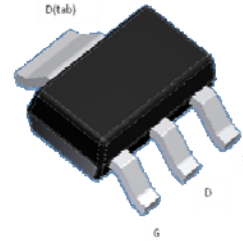

UIS, Rg 100% Tested

Pb-Free Lead Plating & Halogen Free



ABSOLUTE MAXIMUM RATINGS ($T_C = 25^\circ\text{C}$ Unless Otherwise Noted)

PARAMETERS/TEST CONDITIONS		SYMBOL	LIMITS	UNIT
Gate-Source Voltage		V_{GS}	± 20	V
Continuous Drain Current	$T_C = 25^\circ\text{C}$	I_D	6	A
	$T_C = 100^\circ\text{C}$		4	
Pulsed Drain Current ¹		I_{DM}	24	
Avalanche Current		I_{AS}	6	
Avalanche Energy	$L = 0.1\text{mH}, I_D=6\text{A}, R_G=25\Omega$	E_{AS}	1.8	mJ
Repetitive Avalanche Energy ²	$L = 0.05\text{mH}$	E_{AR}	0.9	
Power Dissipation	$T_C = 25^\circ\text{C}$	P_D	6.25	W
	$T_C = 100^\circ\text{C}$		2.5	
Operating Junction & Storage Temperature Range		T_{j}, T_{stg}	-55 to 150	$^\circ\text{C}$

THERMAL RESISTANCE RATINGS

THERMAL RESISTANCE	SYMBOL	TYPICAL	MAXIMUM	UNIT
Junction-to-Case	$R_{\theta JC}$		20	$^\circ\text{C} / \text{W}$
Junction-to-Ambient	$R_{\theta JA}$		100	

¹Pulse width limited by maximum junction temperature.

²Duty cycle $\leq 1\%$

ELECTRICAL CHARACTERISTICS (T_c = 25 °C, Unless Otherwise Noted)

PARAMETER	SYMBOL	TEST CONDITIONS	LIMITS			UNIT
			MIN	TYP	MAX	
STATIC						
Drain-Source Breakdown Voltage	V _{(BR)DSS}	V _{GS} = 0V, I _D = 250μA	30			V
Gate Threshold Voltage	V _{GS(th)}	V _{DS} = V _{GS} , I _D = 250μA	1	1.5	3	
Gate-Body Leakage	I _{GSS}	V _{DS} = 0V, V _{GS} = ±20V			±100	nA
Zero Gate Voltage Drain Current	I _{DSS}	V _{DS} = 24V, V _{GS} = 0V			1	μA
		V _{DS} = 20V, V _{GS} = 0V, T _J = 125 °C			25	
On-State Drain Current ¹	I _{D(ON)}	V _{DS} = 10V, V _{GS} = 10V	6			A
Drain-Source On-State Resistance ¹	R _{DS(ON)}	V _{GS} = 10V, I _D = 6A		19	22	mΩ
		V _{GS} = 4.5V, I _D = 5A		25	30	
Forward Transconductance ¹	g _{fs}	V _{DS} = 5V, I _D = 6A		16		S
DYNAMIC						
Input Capacitance	C _{iss}	V _{GS} = 0V, V _{DS} = 15V, f = 1MHz		520		pF
Output Capacitance	C _{oss}			88		
Reverse Transfer Capacitance	C _{rss}			62		
Gate Resistance	R _g	V _{GS} = 15mV, V _{DS} = 0V, f = 1MHz		2.0		Ω
Total Gate Charge ^{1,2}	Q _g (V _{GS} =10V)	V _{DS} = 15V, V _{GS} = 10V, I _D = 6A		11.5		nC
	Q _g (V _{GS} =4.5V)			5		
Gate-Source Charge ^{1,2}	Q _{gs}			1.6		
Gate-Drain Charge ^{1,2}	Q _{gd}			2.8		
Turn-On Delay Time ^{1,2}	t _{d(on)}	V _{DS} = 15V, I _D = 1A, V _{GS} = 10V, R _{GS} = 6Ω		9		nS
Rise Time ^{1,2}	t _r			12		
Turn-Off Delay Time ^{1,2}	t _{d(off)}			30		
Fall Time ^{1,2}	t _f			15		
SOURCE-DRAIN DIODE RATINGS AND CHARACTERISTICS (T_c = 25 °C)						
Continuous Current	I _S				2	A
Pulsed Current ³	I _{SM}				8	
Forward Voltage ¹	V _{SD}	I _F = I _S , V _{GS} = 0V			1.2	V
Reverse Recovery Time	t _{rr}	I _F = I _S , dI _F /dt = 100A / μS		45		nS
Peak Reverse Recovery Current	I _{RM(REC)}			30		A
Reverse Recovery Charge	Q _{rr}			2		nC

¹Pulse test : Pulse Width $\leq 300 \mu\text{sec}$, Duty Cycle $\leq 2\%$.

²Independent of operating temperature.

³Pulse width limited by maximum junction temperature.

Ordering & Marking Information:

Device Name: EMB20N03Q for SOT-223

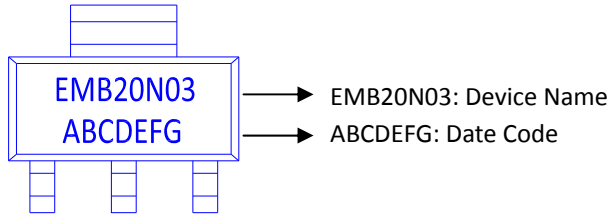

Outline Drawing

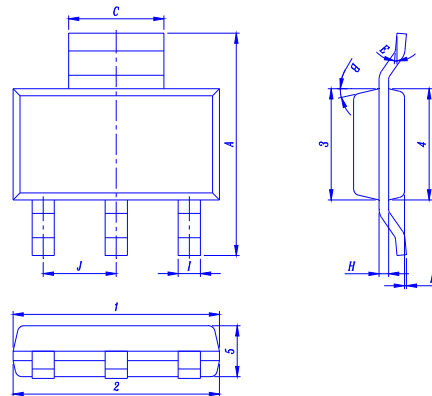

Dimension in mm

Dimension	A	C	D	E	I	H	B	J	1	2	3	4	5
Min.	6.70	2.90	0.02	0°	0.60	0.25			6.30	63.0	3.30	3.30	1.40
Typ.							13°	2.30					
Max.	7.30	3.10	0.10	10°	0.80	0.35			6.70	6.70	3.70	3.70	1.80

Recommended minimum pads

