

N-Channel Logic Level Enhancement Mode Field Effect Transistor

Product Summary:

BV_{DSS}	30V
$R_{DS(on)} (MAX.)$	35m Ω
I_D	5.5A

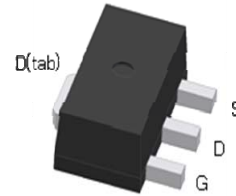
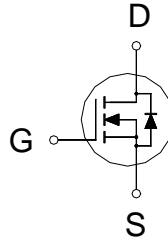

Pb-Free Lead Plating & Halogen Free



ABSOLUTE MAXIMUM RATINGS ($T_A = 25\text{ }^\circ\text{C}$ Unless Otherwise Noted)

PARAMETERS/TEST CONDITIONS		SYMBOL	LIMITS	UNIT
Gate-Source Voltage		V_{GS}	± 20	V
Continuous Drain Current	$T_A = 25\text{ }^\circ\text{C}$	I_D	5.5	A
	$T_A = 70\text{ }^\circ\text{C}$		3.6	
Pulsed Drain Current ¹		I_{DM}	24	
Power Dissipation	$T_A = 25\text{ }^\circ\text{C}$	P_D	1.47	W
	$T_A = 70\text{ }^\circ\text{C}$		0.94	
Operating Junction & Storage Temperature Range		T_{j}, T_{stg}	-55 to 150	$^\circ\text{C}$

THERMAL RESISTANCE RATINGS

THERMAL RESISTANCE	SYMBOL	TYPICAL	MAXIMUM	UNIT
Junction-to-Case	$R_{\theta JC}$		18	$^\circ\text{C} / \text{W}$
Junction-to-Ambient ³	$R_{\theta JA}$		85	

¹Pulse width limited by maximum junction temperature.

²Duty cycle $\leq 1\%$

³85 $^\circ\text{C} / \text{W}$ when mounted on a 1 in² pad of 2 oz copper.

ELECTRICAL CHARACTERISTICS (T_A = 25 °C, Unless Otherwise Noted)

PARAMETER	SYMBOL	TEST CONDITIONS	LIMITS			UNIT
			MIN	TYP	MAX	
STATIC						
Drain-Source Breakdown Voltage	V _{(BR)DSS}	V _{GS} = 0V, I _D = 250μA	30			V
Gate Threshold Voltage	V _{GS(th)}	V _{DS} = V _{GS} , I _D = 250μA	1	1.5	3	
Gate-Body Leakage	I _{GSS}	V _{DS} = 0V, V _{GS} = ±20V			±100	nA
Zero Gate Voltage Drain Current	I _{DSS}	V _{DS} = 24V, V _{GS} = 0V			1	μA
		V _{DS} = 20V, V _{GS} = 0V, T _J = 125 °C			10	
On-State Drain Current ¹	I _{D(ON)}	V _{DS} = 5V, V _{GS} = 10V	5.5			A
Drain-Source On-State Resistance ¹	R _{DS(ON)}	V _{GS} = 10V, I _D = 5.5A		29	35	mΩ
		V _{GS} = 4.5V, I _D = 4.5A		40	52	
Forward Transconductance ¹	g _{fs}	V _{DS} = 5V, I _D = 5.5A		11		S
DYNAMIC						
Input Capacitance	C _{iss}	V _{GS} = 0V, V _{DS} = 15V, f = 1MHz		332		pF
Output Capacitance	C _{oss}			83		
Reverse Transfer Capacitance	C _{rss}			26		
Total Gate Charge ^{1,2}	Q _g	V _{DS} = 15V, V _{GS} = 10V, I _D = 5.5A		7.5		nC
Gate-Source Charge ^{1,2}	Q _{gs}			1.1		
Gate-Drain Charge ^{1,2}	Q _{gd}			2.3		
Turn-On Delay Time ^{1,2}	t _{d(on)}	V _{DS} = 15V, I _D = 1A, V _{GS} = 10V, R _{GS} = 6Ω		8		nS
Rise Time ^{1,2}	t _r			12		
Turn-Off Delay Time ^{1,2}	t _{d(off)}			28		
Fall Time ^{1,2}	t _f			15		
SOURCE-DRAIN DIODE RATINGS AND CHARACTERISTICS (T_C = 25 °C)						
Continuous Current	I _S				2	A
Pulsed Current ³	I _{SM}				8	
Forward Voltage ¹	V _{SD}	I _F = I _S , V _{GS} = 0V			1.3	V
Reverse Recovery Time	t _{rr}	I _F = I _S , dI _F /dt = 100A / μS		60		nS
Reverse Recovery Charge	Q _{rr}				2	nC

¹Pulse test : Pulse Width ≤ 300 μsec, Duty Cycle ≤ 2%.

²Independent of operating temperature.

³Pulse width limited by maximum junction temperature.

Ordering & Marking Information:

Device Name: EMB32N03P for SOT-89

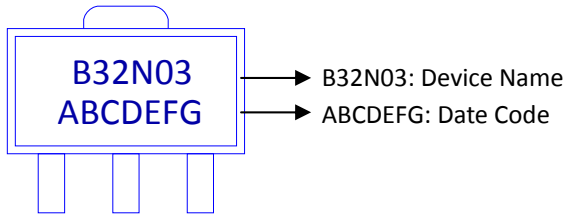

Outline Drawing

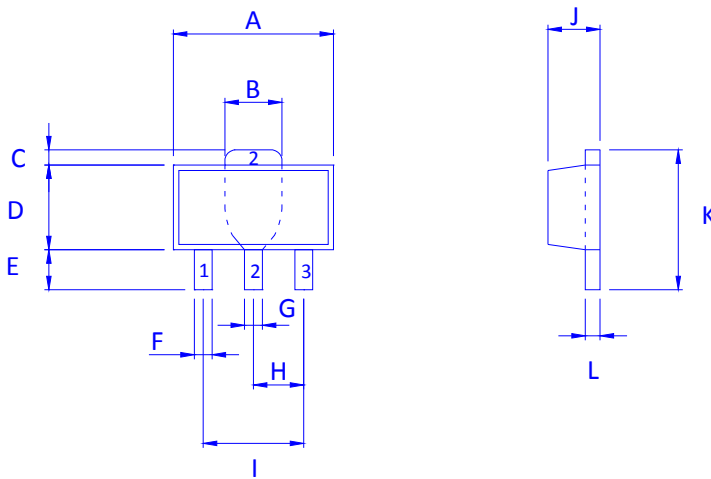

Dimension in mm

Dimension	A	B	C	D	E	F	G	H	I	J	K	L
in.	4.30	1.60	0.40	2.40	0.80	0.40	0.40	1.40	2.80	1.30	3.80	0.30
Typ.												
Max.	4.70	1.80	0.60	2.60	1.40	0.50	0.60	1.60	3.20	1.70	4.60	0.50

Footprint

