

N-Channel Logic Level Enhancement Mode Field Effect Transistor

Product Summary:

BV _{DSS}	100V
R _{DS(on)} (MAX.)	50mΩ
I _D	8A

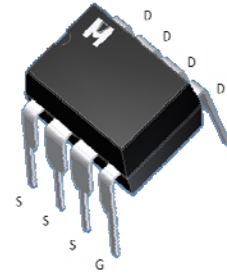
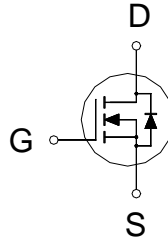

UIS, R_g 100% Tested

Pb-Free Lead Plating & Halogen Free



ABSOLUTE MAXIMUM RATINGS (T_A = 25 °C Unless Otherwise Noted)

PARAMETERS/TEST CONDITIONS		SYMBOL	LIMITS	UNIT
Gate-Source Voltage		V _{GS}	±20	V
Continuous Drain Current	T _A = 25 °C	I _D	8	A
	T _A = 100 °C		6	
Pulsed Drain Current ¹		I _{DM}	32	
Avalanche Current		I _{AS}	15	
Avalanche Energy	L = 0.1mH, I _D =15A, R _G =25Ω	E _{AS}	11.25	mJ
Repetitive Avalanche Energy ²	L = 0.05mH	E _{AR}	5.62	
Power Dissipation	T _A = 25 °C	P _D	3.0	W
	T _A = 100 °C		1.2	
Operating Junction & Storage Temperature Range		T _j , T _{stg}	-55 to 150	°C

THERMAL RESISTANCE RATINGS

THERMAL RESISTANCE	SYMBOL	TYPICAL	MAXIMUM	UNIT
Junction-to-Case	R _{θJC}		21	°C / W
Junction-to-Ambient ³	R _{θJA}		42	

¹Pulse width limited by maximum junction temperature.

²Duty cycle ≤ 1%

³42°C / W when mounted on a 1 in² pad of 2 oz copper.



ELECTRICAL CHARACTERISTICS ($T_c = 25\text{ }^\circ\text{C}$, Unless Otherwise Noted)

PARAMETER	SYMBOL	TEST CONDITIONS	LIMITS			UNIT
			MIN	TYP	MAX	
STATIC						
Drain-Source Breakdown Voltage	$V_{(BR)DSS}$	$V_{GS} = 0V, I_D = 250\mu A$	100			V
Gate Threshold Voltage	$V_{GS(th)}$	$V_{DS} = V_{GS}, I_D = 250\mu A$	1.0	1.7	3.0	
Gate-Body Leakage	I_{GSS}	$V_{DS} = 0V, V_{GS} = \pm 20V$			± 100	nA
Zero Gate Voltage Drain Current	I_{DSS}	$V_{DS} = 80V, V_{GS} = 0V$			1	μA
		$V_{DS} = 70V, V_{GS} = 0V, T_J = 125\text{ }^\circ\text{C}$			25	
On-State Drain Current ¹	$I_{D(ON)}$	$V_{DS} = 10V, V_{GS} = 10V$	7			A
Drain-Source On-State Resistance ¹	$R_{DS(ON)}$	$V_{GS} = 10V, I_D = 8A$		43	50	$m\Omega$
		$V_{GS} = 5V, I_D = 4A$		55	70	
Forward Transconductance ¹	g_{fs}	$V_{DS} = 5V, I_D = 8A$		28		S
DYNAMIC						
Input Capacitance	C_{iss}	$V_{GS} = 0V, V_{DS} = 50V, f = 1MHz$		2780		pF
Output Capacitance	C_{oss}			105		
Reverse Transfer Capacitance	C_{rss}			90		
Gate Resistance	R_g	$V_{GS} = 15mV, V_{DS} = 0V, f = 1MHz$		2.0		Ω
Total Gate Charge ^{1,2}	Q_g	$V_{DS} = 50V, V_{GS} = 10V,$ $I_D = 8A$		55		nC
Gate-Source Charge ^{1,2}	Q_{gs}			9.8		
Gate-Drain Charge ^{1,2}	Q_{gd}			10		
Turn-On Delay Time ^{1,2}	$t_{d(on)}$	$V_{DS} = 50V,$ $I_D = 1A, V_{GS} = 10V, R_{GS} = 6\Omega$		12		nS
Rise Time ^{1,2}	t_r			100		
Turn-Off Delay Time ^{1,2}	$t_{d(off)}$			60		
Fall Time ^{1,2}	t_f			80		
SOURCE-DRAIN DIODE RATINGS AND CHARACTERISTICS ($T_c = 25\text{ }^\circ\text{C}$)						
Continuous Current	I_S				2.5	A
Pulsed Current ³	I_{SM}				10	
Forward Voltage ¹	V_{SD}	$I_F = I_S, V_{GS} = 0V$			1.3	V
Reverse Recovery Time	t_{rr}	$I_F = 10A, di_F/dt = 100A / \mu S$		80		nS
Reverse Recovery Charge	Q_{rr}			260		nC

¹Pulse test : Pulse Width $\leq 300\text{ }\mu\text{sec}$, Duty Cycle $\leq 2\%$.

²Independent of operating temperature.

³Pulse width limited by maximum junction temperature.

Ordering & Marking Information:

Device Name: EMB50N10S for DIP-8

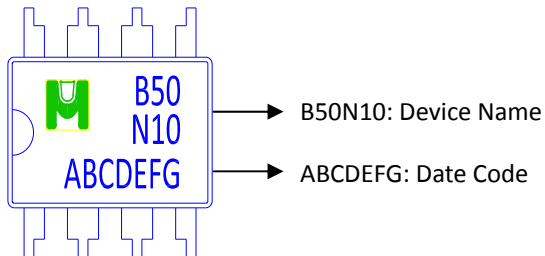

Outline Drawing

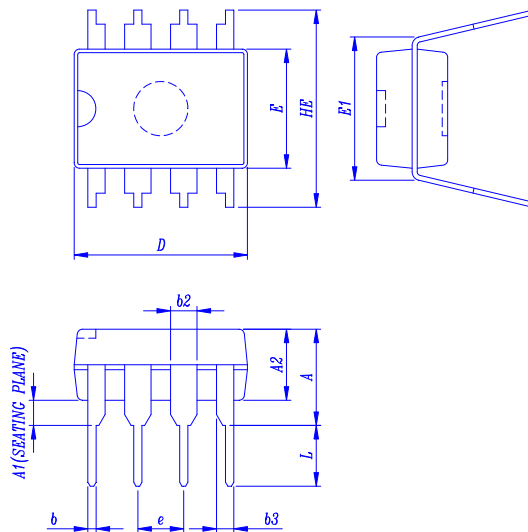

Dimension in mm

Dimension	A	A1	A2	b	b2	b3	c	D	E	E1	e	HE	L
in.		0.38	2.92	0.25	1.14	0.76	0.20	9.01	6.09	7.62			2.92
Typ.											2.54		
Max.	5.34		4.96	0.56	1.78	1.15	0.36	10.16	7.12	8.26		10.92	3.81



TYPICAL CHARACTERISTICS

