

RPM-Based Linear Fan Controller with Hardware Thermal Shutdown

PRODUCT FEATURES

Datasheet

General Description

The EMC2112 is an SMBus, closed-loop, RPM-based fan driver with hardware (HW) thermal shutdown and reset controller. The EMC2112 offers a single High Side fan driver capable of sourcing up to 600mA from a 5V supply.

The EMC2112 utilizes Beta Compensation (an implementation of the BJT or transistor model for thermal diodes) and Resistance Error Correction (REC) to accurately monitor up to three (3) external temperature zones. These features allow great accuracy for CPU substrate thermal diodes on multiple process geometries as well as with discrete diode-connected transistors. Both Beta Compensation and REC can be disabled on the EMC2112 to maintain accuracy when monitoring AMD thermal diodes.

The EMC2112 provides a stand-alone HW thermal shutdown block. The HW thermal shutdown logic can be configured for a few common configurations based on the strapping level of the SHDN_SEL pin on the PCB. The HW thermal shutdown point can be set in 1°C increments by using a discrete resistor connected to the TRIP_SET pin.

The EMC2112 also provides 5V supply 'power good' function with a threshold of 4.5V. This function is provided on the $\overline{\text{RESET}}$ pin.

Applications

- Notebook Computers
- Desktop Computers
- Embedded Applications

Features

- Closed-Loop RPM-Based Fan Controller
 - 1% accuracy with external clock input
 - 3% accuracy with internal clock
 - Internal clock can be used as a source
 - Aging fan detection
- Integrated Linear Fan Driver
 - 600mA drive capability
- HW Thermal Shutdown ($\overline{\text{SYS_SHDN}}$)
 - 1°C incremental set points for thermal shutdown
 - Cannot be disabled by software
- Provides Reset Function ($\overline{\text{RESET}}$) On 5V Supply
- Up to Three (3) Remote Thermal Zones
 - $\pm 1^\circ\text{C}$ accuracy (60°C to 100°C)
 - 0.125°C resolution
 - Designed to support 45nm, 65nm, and 90nm CPU Diodes using BJT and transistor model
 - Eliminates temperature offset due to series resistance from PCB traces and thermal 'Diode'
- Operates From Single 3.0 - 3.6V Supply
 - 5V supply for linear fan driver and reset generator
- SMBus 2.0 and I²C compatible
 - User selectable SMBus address using pull-up resistor on ADDR_SEL pin
 - Supports Block Read and Write functionality
- Available in 20-pin, 4x4 QFN Lead-free RoHS Compliant package

ORDERING INFORMATION:

ORDERING NUMBER	PACKAGE	FEATURES
EMC2112-BP-TR	20-pin QFN 4mm x 4mm (Lead-Free RoHS compliant)	Three External Diodes. High Side Fan driver w/ RPM based Fan Speed Control algorithm. Reset generator. Hardware set critical temperature limit

REEL SIZE IS 4,000 PIECES

This product meets the halogen maximum concentration values per IEC61249-2-21

For RoHS compliance and environmental information, please visit www.smsc.com/rohs

Please contact your SMSC sales representative for additional documentation related to this product such as application notes, anomaly sheets, and design guidelines.



Copyright © 2009 SMSC or its subsidiaries. All rights reserved.

Circuit diagrams and other information relating to SMSC products are included as a means of illustrating typical applications. Consequently, complete information sufficient for construction purposes is not necessarily given. Although the information has been checked and is believed to be accurate, no responsibility is assumed for inaccuracies. SMSC reserves the right to make changes to specifications and product descriptions at any time without notice. Contact your local SMSC sales office to obtain the latest specifications before placing your product order. The provision of this information does not convey to the purchaser of the described semiconductor devices any licenses under any patent rights or other intellectual property rights of SMSC or others. All sales are expressly conditional on your agreement to the terms and conditions of the most recently dated version of SMSC's standard Terms of Sale Agreement dated before the date of your order (the "Terms of Sale Agreement"). The product may contain design defects or errors known as anomalies which may cause the product's functions to deviate from published specifications. Anomaly sheets are available upon request. SMSC products are not designed, intended, authorized or warranted for use in any life support or other application where product failure could cause or contribute to personal injury or severe property damage. Any and all such uses without prior written approval of an Officer of SMSC and further testing and/or modification will be fully at the risk of the customer. Copies of this document or other SMSC literature, as well as the Terms of Sale Agreement, may be obtained by visiting SMSC's website at <http://www.smsc.com>. SMSC is a registered trademark of Standard Microsystems Corporation ("SMSC"). Product names and company names are the trademarks of their respective holders.

SMSC DISCLAIMS AND EXCLUDES ANY AND ALL WARRANTIES, INCLUDING WITHOUT LIMITATION ANY AND ALL IMPLIED WARRANTIES OF MERCHANTABILITY, FITNESS FOR A PARTICULAR PURPOSE, TITLE, AND AGAINST INFRINGEMENT AND THE LIKE, AND ANY AND ALL WARRANTIES ARISING FROM ANY COURSE OF DEALING OR USAGE OF TRADE. IN NO EVENT SHALL SMSC BE LIABLE FOR ANY DIRECT, INCIDENTAL, INDIRECT, SPECIAL, PUNITIVE, OR CONSEQUENTIAL DAMAGES; OR FOR LOST DATA, PROFITS, SAVINGS OR REVENUES OF ANY KIND; REGARDLESS OF THE FORM OF ACTION, WHETHER BASED ON CONTRACT; TORT; NEGLIGENCE OF SMSC OR OTHERS; STRICT LIABILITY; BREACH OF WARRANTY; OR OTHERWISE; WHETHER OR NOT ANY REMEDY OF BUYER IS HELD TO HAVE FAILED OF ITS ESSENTIAL PURPOSE, AND WHETHER OR NOT SMSC HAS BEEN ADVISED OF THE POSSIBILITY OF SUCH DAMAGES.

Table of Contents

Chapter 1	Block Diagram	8
Chapter 2	Pin Layout	9
2.1	Pin Layout for EMC2112	9
2.2	Pin Description for EMC2112	9
Chapter 3	Electrical Specifications	12
3.1	Absolute Maximum Ratings	12
3.2	Electrical Specifications	12
3.3	SMBus Electrical Specifications	14
Chapter 4	System Management Bus Interface Protocol	16
4.1	System Management Bus Interface Protocol	16
4.1.1	SMBus Start Bit	16
4.1.2	SMBus Address and RD / \overline{WR} Bit	16
4.1.3	SMBus Data Bytes	17
4.1.4	SMBus ACK and NACK Bits	17
4.1.5	SMBus Stop Bit	17
4.1.6	SMBus Time-out	17
4.1.7	SMBus and I ² C Compliance	17
4.2	SMBus Protocols	17
4.2.1	Write Byte	18
4.2.2	Read Byte	18
4.2.3	Send Byte	18
4.2.4	Receive Byte	18
4.2.5	Block Write Protocol	19
4.2.6	Block Read Protocol	19
4.2.7	Alert Response Address	19
Chapter 5	General Description	20
5.1	Fan Control Modes of Operation	21
5.2	RPM-Based Fan Speed Control Algorithm (FSC)	21
5.2.1	Programming the RPM-Based Fan Speed Control Algorithm	22
5.3	Tachometer Measurement	22
5.3.1	Stalled Fan	22
5.3.2	Aging Fan or Invalid Drive Detection	23
5.3.3	Clock Source	23
5.4	Spin Up Routine	23
5.5	Ramp Rate Control	24
5.5.1	Temperature Bypass of Ramp Rate Control	25
5.6	Watchdog Timer	25
5.6.1	Power Up Operation	26
5.6.2	Continuous Operation	26
5.7	High Side Fan Driver	26
5.7.1	Overcurrent Limit	26
5.8	Internal Thermal Shutdown (TSD)	26
5.9	Critical/Thermal Shutdown	26
5.9.1	TRIP_SET Pin	27
5.9.2	SHDN_SEL Pin	29
5.9.3	Internal HW_SHDN Signal	29
5.10	5V Reset Controller	30

5.11	Temperature Monitoring	30
5.11.1	Dynamic Averaging	31
5.11.2	Resistance Error Correction	31
5.11.3	Beta Compensation	31
5.11.4	Digital Averaging	32
5.12	Diode Connections	32
5.12.1	Diode Faults	32

Chapter 6 Register Set..... **33**

6.1	Register Map	33
6.1.1	Lock Entries	36
6.2	Temperature Data Registers	36
6.3	Critical/Thermal Shutdown Temperature Registers	37
6.4	TripSet Voltage Register	38
6.5	Ideality Factor Registers	38
6.6	Beta Configuration Registers	39
6.7	REC Configuration Register	41
6.8	Critical Temperature Limit Registers	41
6.9	Configuration Register	42
6.10	Configuration 2 Register	43
6.11	Interrupt Status Register	44
6.12	Error Status Registers	45
6.12.1	Tcrit Status Register	45
6.13	Fan Status Register	46
6.14	Interrupt Enable Register	46
6.15	Fan Interrupt Enable Register	47
6.16	Limit Registers	47
6.17	Fan Setting Register	48
6.18	Fan Configuration 1 Register	48
6.19	Fan Configuration 2 Register	50
6.20	Gain Register	51
6.21	Fan Spin Up Configuration Register	52
6.22	Fan Max Step Register	53
6.23	Fan Minimum Drive Register	54
6.24	Valid TACH Count Register	54
6.25	Fan Drive Fail Band Registers	55
6.26	TACH Target Registers	55
6.27	TACH Reading Registers	55
6.28	Software Lock Register	56
6.29	Product Features Register	57
6.30	Product ID Register	57
6.31	Manufacturer ID Register	58
6.32	Revision Register	58

Chapter 7 Typical Operating Curves..... **59**

Chapter 8 Package Outline..... **62**

8.1	EMC2112 Package Drawings - 20-Pin QFN 4mm x 4mm	62
8.2	Package Marking Information	64

Chapter 9 Datasheet Revision History..... **65**

Datasheet

List of Figures

Figure 1.1	EMC2112 Block Diagram	8
Figure 2.1	EMC2112 Pin Diagram	9
Figure 4.1	SMBus Timing Diagram	16
Figure 5.1	EMC2112 System Diagram	20
Figure 5.2	Spin Up Routine	24
Figure 5.3	Ramp Rate Control	25
Figure 5.4	EMC2112 Critical/Thermal Shutdown Block Diagram	27
Figure 5.5	HW_SHDN Operation	30
Figure 5.6	5V Reset Controller Timing	30
Figure 5.7	Diode Connections.	32
Figure 8.1	EMC2112 Package Drawing - 20-Pin QFN 4mm x 4mm.	62
Figure 8.2	EMC2112 Package Dimensions and Notes - 20-Pin QFN 4mm x 4mm	63
Figure 8.3	EMC2112 PCB Footprint - 20-Pin QFN 4mm x 4mm.	63
Figure 8.4	EMC2112 Package Markings.	64

List of Tables

Table 2.1	Pin Description	9
Table 2.2	Pin Types	10
Table 3.1	Absolute Maximum Ratings	12
Table 3.2	Electrical Specifications	12
Table 3.3	SMBus Electrical Specifications	14
Table 4.1	ADDR_SEL Pin Configuration	16
Table 4.2	Protocol Format	17
Table 4.3	Write Byte Protocol	18
Table 4.4	Read Byte Protocol	18
Table 4.5	Send Byte Protocol	18
Table 4.6	Receive Byte Protocol	18
Table 4.7	Block Write Protocol	19
Table 4.8	Block Read Protocol	19
Table 4.9	Alert Response Address Protocol	19
Table 5.1	Fan Controls Active for Operating Mode	21
Table 5.2	TRIP_SET Resistor Setting	28
Table 5.3	SHDN_SEL Pin Configuration	29
Table 5.4	Dynamic Averaging Behavior	31
Table 6.1	EMC2112 Register Set	33
Table 6.2	Temperature Data Registers	36
Table 6.3	Temperature Data Format	37
Table 6.4	Critical/Thermal Shutdown Temperature Registers	37
Table 6.5	Critical / Thermal Shutdown Data Format	37
Table 6.6	TripSet Voltage Register	38
Table 6.7	Ideality Factor Registers	38
Table 6.8	Ideality Factor Look-Up Table	39
Table 6.9	Substrate Diode Ideality Factor Look-Up Table (BJT Model)	39
Table 6.10	Beta Configuration Registers	39
Table 6.11	Beta Compensation	40
Table 6.12	REC Configuration Register	41
Table 6.13	Tcrit Limit Registers	41
Table 6.14	Configuration Register	42
Table 6.15	Configuration 2 Register	43
Table 6.16	Fault Queue	44
Table 6.17	Conversion Rate	44
Table 6.18	Interrupt Status Register	44
Table 6.19	Error Status Register	45
Table 6.20	Fan Status Register	46
Table 6.21	Interrupt Enable Register	46
Table 6.22	Fan Interrupt Enable Register	47
Table 6.23	Limit Registers	47
Table 6.24	Fan Setting Register	48
Table 6.25	Fan Configuration 1 Register	48
Table 6.26	Range Decode	49
Table 6.27	Minimum Edges for Fan Rotation	49
Table 6.28	Update Time	49
Table 6.29	Fan Configuration 1 Register	50
Table 6.30	Derivative Options	51
Table 6.31	Error Range Options	51
Table 6.32	Gain Register	51
Table 6.33	Gain Decode	52
Table 6.34	Fan Spin Up Configuration Register	52

**Datasheet**

Table 6.35 DRIVE_FAIL_CNT[1:0] Bit Decode	52
Table 6.36 Spin Level	53
Table 6.37 Spin Time.	53
Table 6.38 Fan Max Step Register	53
Table 6.39 Minimum Fan Drive Register	54
Table 6.40 Valid TACH Count Register	54
Table 6.41 Fan Drive Fail Band Registers.	55
Table 6.42 TACH Target Registers	55
Table 6.43 TACH Reading Registers	55
Table 6.44 Software Lock Register	56
Table 6.45 Product Features Register.	57
Table 6.46 ADDR_SEL Pin Configuration	57
Table 6.47 SHDN_CH Pin Configuration.	57
Table 6.48 Product ID Register	57
Table 6.49 Manufacturer ID Register.	58
Table 6.50 Revision Register.	58
Table 9.1 Customer Revision History	65

Chapter 1 Block Diagram

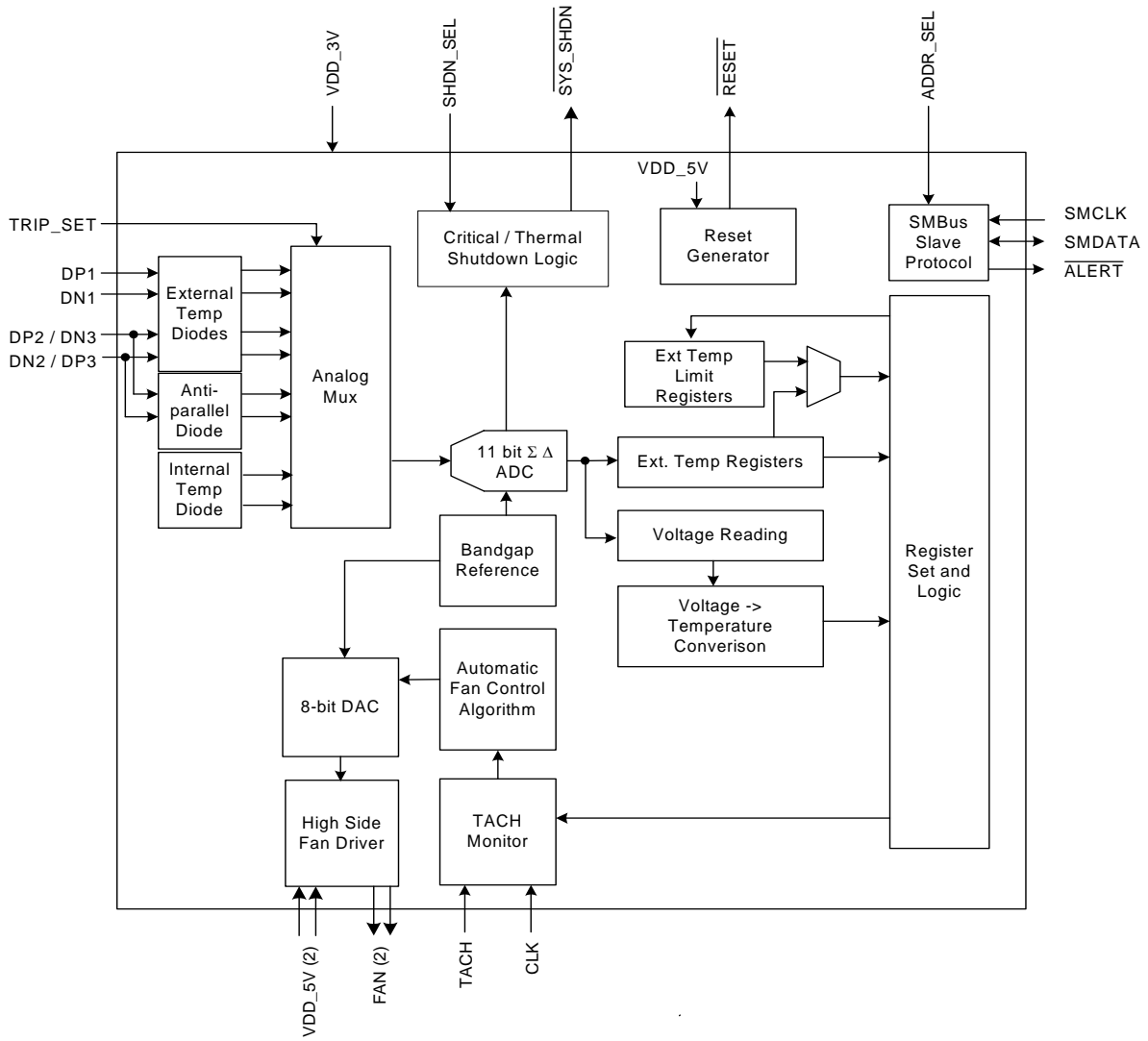

Figure 1.1 EMC2112 Block Diagram

Chapter 2 Pin Layout

2.1 Pin Layout for EMC2112

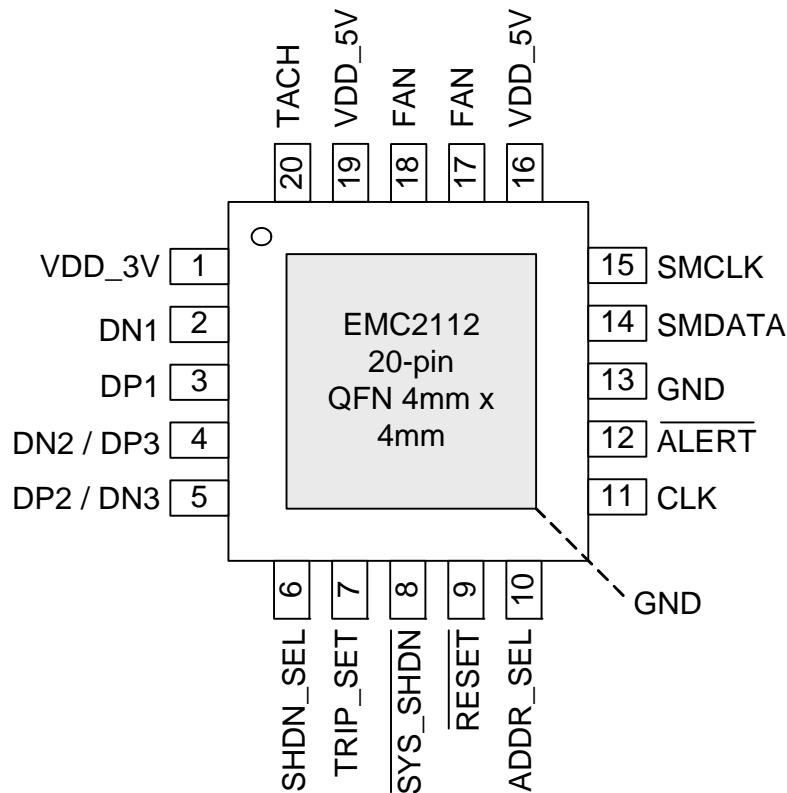

Figure 2.1 EMC2112 Pin Diagram

2.2 Pin Description for EMC2112

Table 2.1 Pin Description

PIN	NAME	FUNCTION	TYPE
1	VDD_3V	3.3V Supply Voltage	Power
2	DN1	Negative (cathode) Analog Input for External Diode 1	AIO
3	DP1	Positive (anode) Analog Input for External Diode 1	AIO
4	DN2 / DP3	Negative (cathode) Analog Input for External Diode 2 and Positive (anode) Analog Input for External Diode 3	AIO

Table 2.1 Pin Description (continued)

PIN	NAME	FUNCTION	TYPE
5	DP2 / DN3	Positive (anode) Analog Input for External Diode 2 and Negative (cathode) Analog Input for External Diode 3	AIO
6	SHDN_SEL	Determines HW Shutdown temperature channel	DIT
7	TRIP_SET	Voltage input to determine HW Shutdown threshold temperature	AIO
8	$\overline{\text{SYS_SHDN}}$	Active low Critical System Shutdown output	OD (5V)
9	$\overline{\text{RESET}}$	Push-Pull, active low reset output	DO
10	ADDR_SEL	Selects SMBus Address	DIT
11	CLK	Tachometer clock input	DI (5V)
		Tachometer clock output	DO
12	$\overline{\text{ALERT}}$	Open drain, active low interrupt. Requires external pull-up resistor	OD (5V)
13	GND	Ground Connection	Power
14	SMDATA	SMBus data input/output - requires external pull-up resistor	DIOD (5V)
15	SMCLK	SMBus clock input - requires external pull-up resistor	DI (5V)
16	VDD_5V	5V supply input for the linear fan driver. Both VDD_5V pins should be connected to same 5V supply.	Power
17	FAN	Linear fan drive signal. Both FAN pins should be connected together.	AO
18	FAN	Linear fan drive signal. Both FAN pins should be connected together.	AO
19	VDD_5V	5V supply input for the linear fan driver. Both VDD_5V pins should be connected to same 5V supply.	Power
20	TACH	Tachometer input from Fan	DI (5V)

The pin type are described in [Table 2.2](#). All pins labeled with (5V) are 5V tolerant.

Table 2.2 Pin Types

PIN TYPE	DESCRIPTION
Power	This pin is used to supply power or ground to the device.
DI	Digital Input - this pin is used as a digital input. This pin is 5V tolerant.
AO	Analog Output - this pin is used as an output for analog signals.
AIO	Analog Input / Output - this pin is used as an I/O for analog signals.

Table 2.2 Pin Types (continued)

PIN TYPE	DESCRIPTION
DO	Push / Pull Digital Output - this pin is used as a digital output. It can both source and sink current.
DIOD	Digital Input / Open Drain Output - this pin is used as a digital I/O. When it is used as an output, it is open drain and requires a pull-up resistor. This pin is 5V tolerant.
DIO	Digital Input / Output - this pin is used as a digital I/O. It is push-pull and can sink or source up to 8mA.
OD	Open Drain Digital Output - this pin is used as a digital output. It is open drain and requires a pull-up resistor. This pin is 5V tolerant.
DIT	Tri-stated Digital Input - this pin is a digital input that supports 3 logic levels at the input: logic high, logic low, or high impedance (open).

Chapter 3 Electrical Specifications

3.1 Absolute Maximum Ratings

Table 3.1 Absolute Maximum Ratings

Voltage on VDD_5V Pins and 5V tolerant pins (see Table 2.1)	-0.3 to 6.5	V
Voltage on VDD_3V pin	-0.3 to 4	V
Voltage on FAN pins	-0.3 to VDD_5V + 0.3	V
Voltage on any other pin to GND	-0.3 to VDD_3V + 0.3	V
Package Power Dissipation	0.9 up to $T_A = 85^\circ\text{C}$ Note 3.2	W
Junction to Ambient - 20 pin QFN (θ_{JA}) Note 3.3	40	$^\circ\text{C/W}$
Operating Ambient Temperature Range	0 to 85	$^\circ\text{C}$
Operating Die Temperature Range	0 to 125	$^\circ\text{C}$
Storage Temperature Range	-55 to 150	$^\circ\text{C}$
ESD Rating, All Pins, HBM	2000	V

These ratings are absolute maximum values. Exceeding these values or operating at these values for an extended period of time may cause permanent damage to the device.

Note 3.1 All voltages are relative to ground.

Note 3.2 The Package Power Dissipation specification assumes a thermal via design consisting of four 20mil vias connected to the ground plane with a 2.6mm x 2.6mm thermal landing.

Note 3.3 Junction to Ambient (θ_{JA}) is dependent on the design of the thermal vias. Without thermal vias and a thermal landing, the θ_{JA} is approximately 60°C/W including localized PCB temperature increase.

3.2 Electrical Specifications

Table 3.2 Electrical Specifications

VDD_3V = 3V to 3.6V, VDD_5V = 4.6V - 5.5V, $T_A = 0^\circ\text{C}$ to 85°C all Typical values at $T_A = 27^\circ\text{C}$ unless otherwise noted.						
CHARACTERISTIC	SYMBOL	MIN	TYP	MAX	UNIT	CONDITIONS
DC Power						
3.3V Supply Voltage	V_{DD_3V}	3	3.3	3.6	V	
5V Supply Voltage	V_{DD_5V}	4.6	5	5.5	V	
Supply Current from VDD_3V pin	I_{DD3}		0.750	1.6	mA	Fan Driver enabled 4 conversions / sec
Supply Current from VDD_5V pin	I_{DD5}		50		uA	Fan Driver enabled

Table 3.2 Electrical Specifications (continued)

VDD_3V = 3V to 3.6V, VDD_5V = 4.6V - 5.5V, T _A = 0°C to 85°C all Typical values at T _A = 27°C unless otherwise noted.						
CHARACTERISTIC	SYMBOL	MIN	TYP	MAX	UNIT	CONDITIONS
External Temperature Monitors						
Temperature Accuracy			±0.25	±1	°C	60°C < T _{DIODE} < 100°C 30°C < T _{DIE} < 85°C (Note 3.4)
			±0.5	±2	°C	0°C < T _{DIODE} < 125°C, 0°C < T _{DIE} < 115°C (Note 3.4)
Temperature Resolution			0.125		°C	
Diode Decoupling Capacitor	C _{FILTER}			2700	pF	Connected across external 2N3904 diode or AMD diode (Note 3.5)
Resistance Error Corrected	R _{SERIES}			100	Ohm	Series resistance in DP and DN lines
Internal Temperature Monitor						
Temperature Accuracy			±1	±2	°C	(Note 3.4)
Temperature Resolution			0.125		°C	
Reset Generator						
Reset Voltage	V _{RESET}	4.3	4.4	4.5	V	V _{DD_5V} rising edge 3V < V _{DD_3V} < 3.6V
Hysteresis	ΔV _{RESET}		100		mV	
Time Delay	t _{RESET}		220		ms	
High Side Fan Driver						
Output High Voltage from 5V Supply	V _{OH_5V}			VDD_5V - 0.4	V	I _{SOURCE} = 600mA, VDD_5V = 5V
Fan Drive Current	I _{SOURCE}			600	mA	
Overcurrent Limit	I _{OVER}		1500		mA	Momentary Current drive at startup for < 2 seconds
DC Short Circuit Current Limit	I _{SHORT}		800		mA	Sourcing current, Thermal shutdown not triggered, FAN_OUT = 0V
Short Circuit Delay	t _{DFS}		2		s	
Output Capacitive Load	C _{LOAD}			100	uF	
ESR on C _{LOAD}	R _{ESR}	0		2	Ohm	
RPM-Based Fan Controller						
TACH Range	TACH	480		16000	RPM	

Table 3.2 Electrical Specifications (continued)

VDD_3V = 3V to 3.6V, VDD_5V = 4.6V - 5.5V, T _A = 0°C to 85°C all Typical values at T _A = 27°C unless otherwise noted.						
CHARACTERISTIC	SYMBOL	MIN	TYP	MAX	UNIT	CONDITIONS
RPM Control Accuracy	Δ_{TACH}		±0.25	±0.5	%	External oscillator 32.768kHz
	Δ_{TACH}		±0.5	±1	%	Internal Oscillator 40°C < T _{DIE} < 100°C
Thermal Shutdown						
Thermal Shutdown Threshold	TSD _{TH}		150		°C	
Thermal Shutdown Hysteresis	TSD _{HYST}		50		°C	
SMBus and Digital I/O pins						
Output High Voltage	V _{OH}	VDD_3V-0.4			V	4 mA current drive
Output Low Voltage	V _{OL}			0.5	V	4 mA current sink

Note 3.4 T_{DIE} refers to the internal die temperature and may not match T_A due to self heating of the device. The internal temperature sensor will return T_{DIE}.

Note 3.5 Contact SMSC for Application Notes and guidelines when measuring GPU processor diodes and CPU processor diodes.

Note 3.6 The \overline{ALERT} , $\overline{SYS_SHDN}$, \overline{SMDATA} , and \overline{SMCLK} pins will not glitch low upon power up when pulled to VDD or another voltage.

3.3 SMBus Electrical Specifications

Table 3.3 SMBus Electrical Specifications

VDD_3V = 3V to 3.6V, VDD_5V = 4.6 to 5.5V, T _A = 0°C to 85°C Typical values are at T _A = 27°C unless otherwise noted.						
CHARACTERISTIC	SYMBOL	MIN	TYP	MAX	UNITS	CONDITIONS
SMBus Interface						
Input High Voltage	V _{IH}	2.0			V	
Input Low Voltage	V _{IL}			0.8	V	
Input High/Low Current	I _{IH} / I _{IL}	-1		1	uA	
Input Capacitance	C _{IN}		5		pF	
Output Low Sink Current			4		mA	SMDATA = 0.5V
SMBus Timing						
Clock Frequency	f _{SMB}	10		400	kHz	
Spike Suppression	t _{SP}			50	ns	

Table 3.3 SMBus Electrical Specifications (continued)

VDD_3V = 3V to 3.6V, VDD_5V = 4.6 to 5.5V, T _A = 0°C to 85°C Typical values are at T _A = 27°C unless otherwise noted.						
CHARACTERISTIC	SYMBOL	MIN	TYP	MAX	UNITS	CONDITIONS
Bus Free Time Start to Stop	t _{BUF}	1.3			us	
Setup Time: Start	t _{SU:STA}	0.6			us	
Setup Time: Stop	t _{SU:STP}	0.6			us	
Data Hold Time	t _{HD:DAT}	0.6		6	us	
Data Setup Time	t _{SU:DAT}	0.6		72	us	
Clock Low Period	t _{LOW}	1.3			us	
Clock High Period	t _{HIGH}	0.6			us	
Clock/Data Fall time	t _{FALL}			300	ns	Min = 20+0.1C _{LOAD} ns
Clock/Data Rise time	t _{RISE}			300	ns	Min = 20+0.1C _{LOAD} ns
Capacitive Load	C _{LOAD}			400	pF	per bus line

Chapter 4 System Management Bus Interface Protocol

4.1 System Management Bus Interface Protocol

The EMC2112 communicates with a host controller, such as an SMSC SIO, through the SMBus. The SMBus is a two-wire serial communication protocol between a computer host and its peripheral devices. A detailed timing diagram is shown in Figure 4.1. Stretching of the SMCLK signal is supported, however the EMC2112 will not stretch the clock signal.

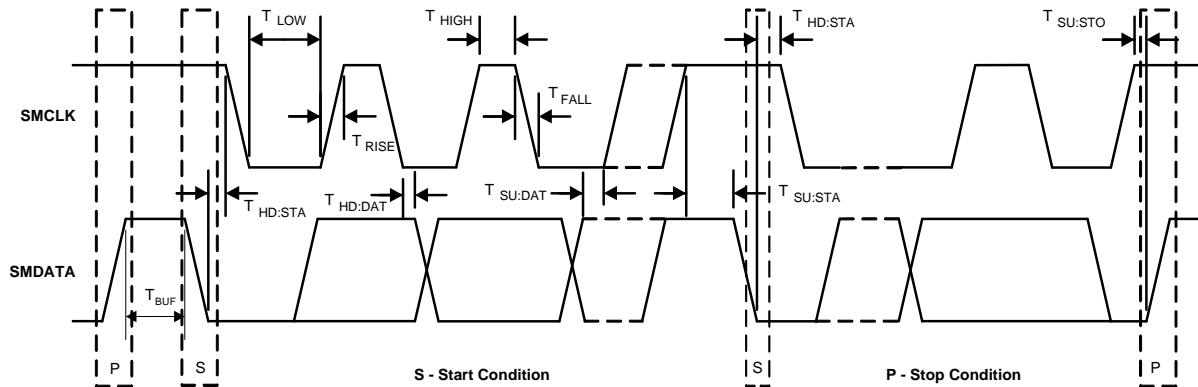

Figure 4.1 SMBus Timing Diagram

4.1.1 SMBus Start Bit

The SMBus Start bit is defined as a transition of the SMBus Data line from a logic '1' state to a logic '0' state while the SMBus Clock line is in a logic '1' state. When the EMC2112 detects an SMBus Start bit, it will disable the BC-Link protocol circuitry and communicate using the SMBus Protocol

4.1.2 SMBus Address and RD / \overline{WR} Bit

The SMBus Address Byte consists of the 7-bit client address followed by a -bit RD / \overline{WR} indicator. If this RD / WR bit is a logic '0', then the SMBus Host is writing data to the client device. If this RD / \overline{WR} bit is a logic '1', then the SMBus Host is reading data from the client device.

The slave address is determined at power up by the pin-state of the ADDR_SEL pin as shown in Table 4.1.

Table 4.1 ADDR_SEL Pin Configuration

ADDR_SEL PIN STATE	SMBUS SLAVE ADDRESS
'0'	0101_111xb
'High Z'	0111_101xb
'1'	0101_110xb

Datasheet

4.1.3 SMBus Data Bytes

All SMBus Data bytes are sent most significant bit first and composed of 8-bits of information.

4.1.4 SMBus ACK and NACK Bits

The SMBus client will acknowledge all data bytes that it receives (as well as the client address if it matches and the ARA address if the ATF_INT# pin is asserted). This is done by the client device pulling the SMBus Data line low after the 8th bit of each byte that is transmitted.

The Host will NACK (not acknowledge) the data received from the client by holding the SMBus data line high after the 8th data bit has been sent.

4.1.5 SMBus Stop Bit

The SMBus Stop bit is defined as a transition of the SMBus Data line from a logic '0' state to a logic '1' state while the SMBus clock line is in a logic '1' state. When the EMC2112 detects an SMBus Stop bit, and it has been communicating with the SMBus protocol, it will reset its client interface and prepare to receive further communications.

4.1.6 SMBus Time-out

The EMC2112 includes an SMBus time-out feature. Following a 30ms period of inactivity on the SMBus, the device will time-out and reset the SMBus interface. The timeout can be disabled by setting the DIS_TO bit in the Configuration 2 register.

4.1.7 SMBus and I²C Compliance

The major difference between SMBus and I²C devices is highlighted here. For complete compliance information refer to the SMBus 2.0 specification.

1. Minimum frequency for SMBus communications is 10kHz.
2. The client protocol will reset if the clock is held for longer than 30ms.
3. The slave protocol will reset if both the clock and data lines are held high for longer than 150us.
4. I²C devices do not support the Alert Response Address functionality (which is optional for SMBus).
5. The Block Read and Block Write protocols are only compliant with I²C data formatting. They do not support SMBus formatting for Block Read and Block Write protocols.

4.2 SMBus Protocols

The EMC2112 is SMBus 2.0 compatible and supports Send Byte, Read Byte, Receive Byte and Write Byte as valid protocols as shown below. It will respond to the Alert Response Address protocol but is not in full compliance.

All of the below protocols use the convention in [Table 4.2](#).

Table 4.2 Protocol Format

DATA SENT TO DEVICE	DATA SENT TO THE HOST
# of bits sent	# of bits sent

4.2.1 Write Byte

The Write Byte is used to write one byte of data to the registers as shown below [Table 4.3](#):

Table 4.3 Write Byte Protocol

START	SLAVE ADDRESS	WR	ACK	REGISTER ADDRESS	ACK	REGISTER DATA	ACK	STOP
1 -> 0	0111_101	0	0	XXh	0	XXh	0	0 -> 1

4.2.2 Read Byte

The Read Byte protocol is used to read one byte of data from the registers as shown in [Table 4.4](#).

Table 4.4 Read Byte Protocol

START	SLAVE ADDRESS	WR	ACK	Register Address	ACK	START	Slave Address	RD	ACK	Register Data	NACK	STOP
1 -> 0	0111_101	0	0	XXh	0	0 -> 1	0111_101	1	0	XXh	1	0 -> 1

4.2.3 Send Byte

The Send Byte protocol is used to set the internal address register pointer to the correct address location. No data is transferred during the Send Byte protocol as shown in [Table 4.5](#).

Table 4.5 Send Byte Protocol

START	SLAVE ADDRESS	WR	ACK	REGISTER ADDRESS	ACK	STOP
1 -> 0	0111_101	0	0	XXh	0	0 -> 1

4.2.4 Receive Byte

The Receive Byte protocol is used to read data from a register when the internal register address pointer is known to be at the right location (e.g. set via Send Byte). This is used for consecutive reads of the same register as shown in [Table 4.6](#).

Table 4.6 Receive Byte Protocol

START	SLAVE ADDRESS	RD	ACK	REGISTER DATA	NACK	STOP
1 -> 0	0111_101	1	0	XXh	1	0 -> 1

Datasheet

4.2.5 Block Write Protocol

The Block Write is used to write multiple data bytes to a group of contiguous registers as shown in [Table 4.7](#). It is an extension of the Write Byte Protocol.

Table 4.7 Block Write Protocol

START	SLAVE ADDRESS	WR	ACK	REGISTER ADDRESS	ACK	REGISTER DATA	ACK
1 -> 0	0111_101	0	0	XXh	0	XXh	0
REGISTER DATA	ACK	REGISTER DATA	ACK	...	REGISTER DATA	ACK	STOP
XXh	0	XXh	0	...	XXh	0	0 -> 1

4.2.6 Block Read Protocol

The Block Read is used to read multiple data bytes from a group of contiguous registers as shown in [Table 4.8](#). It is an extension of the Read Byte Protocol.

Table 4.8 Block Read Protocol

START	SLAVE ADDRESS	WR	ACK	REGISTER ADDRESS	ACK	START	SLAVE ADDRESS	RD	ACK	REGISTER DATA
1->0	0111_101	0	0	XXh	0	1->0	0111_101	1	0	XXh
ACK	REGISTER DATA	ACK	REGISTER DATA	ACK	REGISTER DATA	ACK	...	REGISTER DATA	NACK	STOP
0	XXh	0	XXh	0	XXh	0	...	XXh	1	0 -> 1

4.2.7 Alert Response Address

The $\overline{\text{ALERT}}$ output can be used as a processor interrupt or as an SMBus Alert when configured to operate as an interrupt.

When it detects that the $\overline{\text{ALERT}}$ pin is asserted, the host will send the Alert Response Address (ARA) to the general address of 0001_100xb. All devices with active interrupts will respond with their client address as shown in [Table 4.9](#).

Table 4.9 Alert Response Address Protocol

START	ALERT RESPONSE ADDRESS	RD	ACK	DEVICE ADDRESS	NACK	STOP
0 -> 1	0001_100	1	0	0111_1010b	1	1 -> 0

The EMC2112 will respond to the ARA in the following way if the $\overline{\text{ALERT}}$ pin is asserted.

1. Send Slave Address and verify that full slave address was sent (i.e. the SMBus communication from the device was not prematurely stopped due to a bus contention event).
2. Set the MASK bit to clear the $\overline{\text{ALERT}}$ pin.

Chapter 5 General Description

The EMC2112 monitors up to three (3) external temperature channels. Each of the external temperature channels can employ both Beta Compensation (an implementation of the BJT or transistor model for thermal diodes) and Resistance Error Correction for use with thermal diodes while the third channel is hardwired to measure a discrete diode connected NPN or PNP transistor. The temperature data is available over a standard 2-wire serial interface using SMBus read commands. The temperature monitoring is described in more detail in [Section 5.11, "Temperature Monitoring"](#).

The EMC2112 includes a closed-loop RPM-based Fan Control Algorithm for each fan driver. The host writes the desired fan speed into a register of the EMC2112 via the SMBus and the integrated fan controller will maintain the fan at the desired speed using fan speed feedback from the TACH output from a 3-wire fan. The fan control algorithm controls an integrated 5V, 600mA, linear fan driver.

The EMC2112 provides the system with a hardware based critical/thermal shutdown function. This critical/thermal shutdown function integrates critical signals from both the CPU and power supply and the analog circuitry to monitor a specific temperature channel based on the system configuration. The critical/thermal shutdown temperature threshold is configured on the PCB through a simple discrete resistor. The Critical/Thermal Shutdown function is described in more detail in [Section 5.9, "Critical/Thermal Shutdown"](#).

An example of a typical system configuration for the EMC2112 is provided in [Figure 5.1](#).

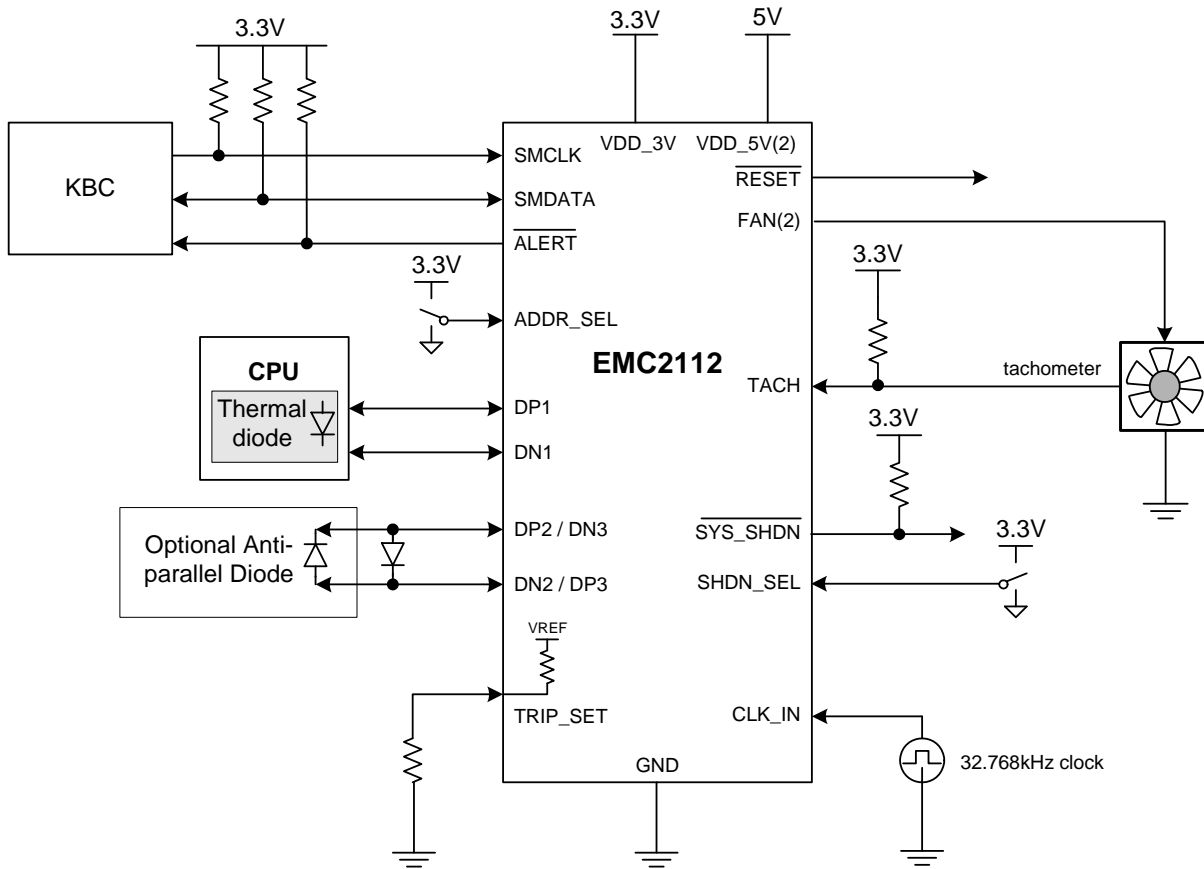

Figure 5.1 EMC2112 System Diagram

5.1 Fan Control Modes of Operation

The EMC2112 has two modes of operation for the fan driver. Each mode of operation uses the Ramp Rate control and Spin Up Routine.

1. Direct Setting Mode - in this mode of operation, the user directly controls the fan drive setting. Updating the Fan Driver Setting Register (see [Section 6.17](#)) will instantly update the fan drive. Ramp Rate control is optional and enabled via the EN_RRC bits.
 - Whenever the Direct Setting Mode is enabled, the current drive will be changed to what was last written into the Fan Driver Setting Register.
2. Fan Speed Control Mode (FSC) - in this mode of operation, the user determines a target tachometer count and the drive setting is automatically updated to achieve this target speed. The algorithm uses the Spin Up Routine and has user definable ramp rate controls.

Table 5.1 Fan Controls Active for Operating Mode

DIRECT SETTING MODE	FSC MODE
Fan Driver Setting (read / write)	Fan Driver Setting (read only)
EDGES[1:0]	EDGES[1:0] (Fan Configuration)
-	RANGE[1:0] (Fan Configuration)
UPDATE[2:0] (Fan Configuration)	UPDATE[2:0] (Fan Configuration)
LEVEL (Spin Up Configuration)	LEVEL (Spin Up Configuration)
SPINUP_TIME[1:0] (Spin Up Configuration)	SPINUP_TIME[1:0] (Spin Up Configuration)
Fan Max Step	Fan Max Step
-	Fan Minimum Drive
Valid TACH Count	Valid TACH Count
-	TACH Target (read / write)
TACH Reading	TACH Reading
-	DRIVE_FAIL_CNT[1:0] and Drive Band Fail Registers

5.2 RPM-Based Fan Speed Control Algorithm (FSC)

The EMC2112 includes a RPM-based Fan Speed Control Algorithm for the fan driver.

This fan control algorithm uses Proportional, Integral, and Derivative terms to automatically approach and maintain the system's desired fan speed to an accuracy directly proportional to the accuracy of the clock source.

The desired tachometer count is set by the user inputting the desired number of 32.768KHz cycles that occur per fan revolution. This is done by setting the TACH Target Register. The user may change the target count at any time. The user may also set the target count to FFh in order to disable the fan driver for lower current operation.

For example, if a desired RPM rate for a 2-pole fan is 3000 RPMs, then the user would input the hexadecimal equivalent of 1296 (51h in the TACH Target Register). This number represents the number of 32.768KHz cycles that would occur during the time it takes the fan to complete a single revolution when it is spinning at 3000RPMs.

The EMC2112's RPM-based Fan Speed Control Algorithm has programmable configuration settings for parameters such as ramp-rate control and spin up conditions. The fan driver automatically detects and attempts to alleviate a stalled/stuck fan condition while also asserting the ALERT pin. The EMC2112 works with fans that operate up to 16,000 RPMs and provide a valid tachometer signal. The fan controller will function either with an externally supplied 32.768KHz clock source or with its own internal 32kHz oscillator depending on the required accuracy.

5.2.1 Programming the RPM-Based Fan Speed Control Algorithm

The RPM-based Fan Speed Control Algorithm is disabled upon device power up. The following registers control the algorithm. The EMC2112 fan control registers are pre-loaded with defaults that will work for a wide variety of fans so only the TACH Target Register is required to set a fan speed. The other fan control registers can be used to fine-tune the algorithm behavior based on application requirements.

Note that steps 1 - 6 are optional and need only be performed if the default settings do not provide the desired fan response.

1. Set the Spin Up Configuration Register to the Spin Up Level and Spin Time desired.
2. Set the Fan Step Register to the desired step size.
3. Set the Fan Minimum Drive Register to the minimum drive value that will maintain fan operation.
4. Set the Update Time, and Edges options in the Fan Configuration Register.
5. Set the Valid TACH Count Register to the highest tach count that indicates the fan is spinning.
6. Set the TACH Target Register to the desired tachometer count.
7. Enable the RPM-based Fan Speed Control Algorithm by setting the EN_ALGO bit.

5.3 Tachometer Measurement

The tachometer measurement circuitry is used in conjunction with the RPM-based Fan Speed Control Algorithm to update the fan driver output. Additionally, it can be used in Direct Setting mode as a diagnostic for host based fan control.

This method monitors the TACH signal in real time. It constantly updates the tachometer measurement by reporting the number of clocks between a user programmed number of edges on the TACH signal.

The tachometer measurement provides fast response times for the RPM-based Fan Speed Control Algorithm and the data is presented as a count value that represents the fan RPM period. When this method is used, all fan target values must be input as a count value for proper operation.

APPLICATION NOTE: The tachometer measurement method works independently of the drive settings. If the device is put into Direct Setting and the fan drive is set at a level that is lower than the fan can operate (including zero drive), then the tachometer measurement may signal a Stalled Fan condition and assert an interrupt.

5.3.1 Stalled Fan

A Stalled fan is detected if the tach counter exceeds the user-programmable Valid TACH Count setting then it will flag the fan as stalled and trigger an interrupt.

If the RPM-based Fan Speed Control Algorithm is enabled, the algorithm will automatically attempt to restart the fan until it detects a valid tachometer level or is disabled.

Datasheet

The FAN_STALL Status bit indicates that a stalled fan was detected. This bit is checked conditionally depending on the mode of operation.

- Whenever the Direct Setting Mode is enabled or whenever the Spin Up Routine is enabled, the FAN_STALL interrupt will be masked for the duration of the programmed Spin Up Time (see [Section 6.21](#)) to allow the fan an opportunity to reach a valid speed without generating unnecessary interrupts.
- In Direct Setting Mode with the tachometer measurement using the Tach Period Measurement method, whenever the TACH Reading Register value exceeds the Valid TACH Count Register setting, the FAN_STALL status bit will be set.
- When using the RPM-based Fan Speed Control Algorithm, the stalled fan condition is checked whenever the Update Time is met and the fan drive setting is updated. It is not a continuous check.

5.3.2 Aging Fan or Invalid Drive Detection

This is useful to detect aging fan conditions (where the fan's natural maximum speed degrades over time) or incorrect fan speed settings. The EMC2112 contains circuitry that detects that the programmed fan speed can be reached by the fan. If the target fan speed cannot be reached within a user defined band of tach counts at maximum drive then the DRIVE_FAIL status bits are set and the ALERT pin is asserted.

5.3.3 Clock Source

The CLK pin can be configured as an input for the EMC2112 or as an output to drive additional devices with the internally generated tachometer clock (see [Section 6.9](#)).

When the CLK pin is configured as an input to the EMC2112, then a 32.768kHz clock must be provided. This clock is used to by the Tachometer measurement circuitry and will directly affect the accuracy of this measurement.

When the CLK pin is configured as an output, then it will be driven at the same frequency as the internal tachometer clock.

5.4 Spin Up Routine

The EMC2112 also contains programmable circuitry to control the spin up behavior of the fan driver to ensure proper fan operation.

The Spin Up Routine is initiated in Direct Setting mode when the setting value changes from 00h to anything else.

When the Fan Speed Control Algorithm is enabled, the Spin Up Routine is initiated under the following conditions when the Tach Period Measurement method of tach measurement is used:

1. The TACH Target Register value changes from a value of FFh to a value that is less than the Valid TACH Count (see [Section 6.24](#)).
2. The RPM-based Fan Speed Control Algorithm's measured TACH Reading Register value is greater than the Valid TACH Count setting.

When the Spin Up Routine is operating, the fan driver is set to full scale (optional) for one quarter of the total user defined spin up time. For the remaining spin up time, the fan driver output is set a a user defined level (30% through 65% drive).

After the Spin Up Routine has finished, the EMC2112 measures the TACH signal. If the measured TACH Reading Register value is higher than the Valid TACH Count Register setting, the FAN_SPIN status bit is set and the Spin Up Routine will automatically attempt to restart the fan.

[Figure 5.2](#) shows an example of the Spin Up Routine in response to a programmed fan speed change based on the first condition above.

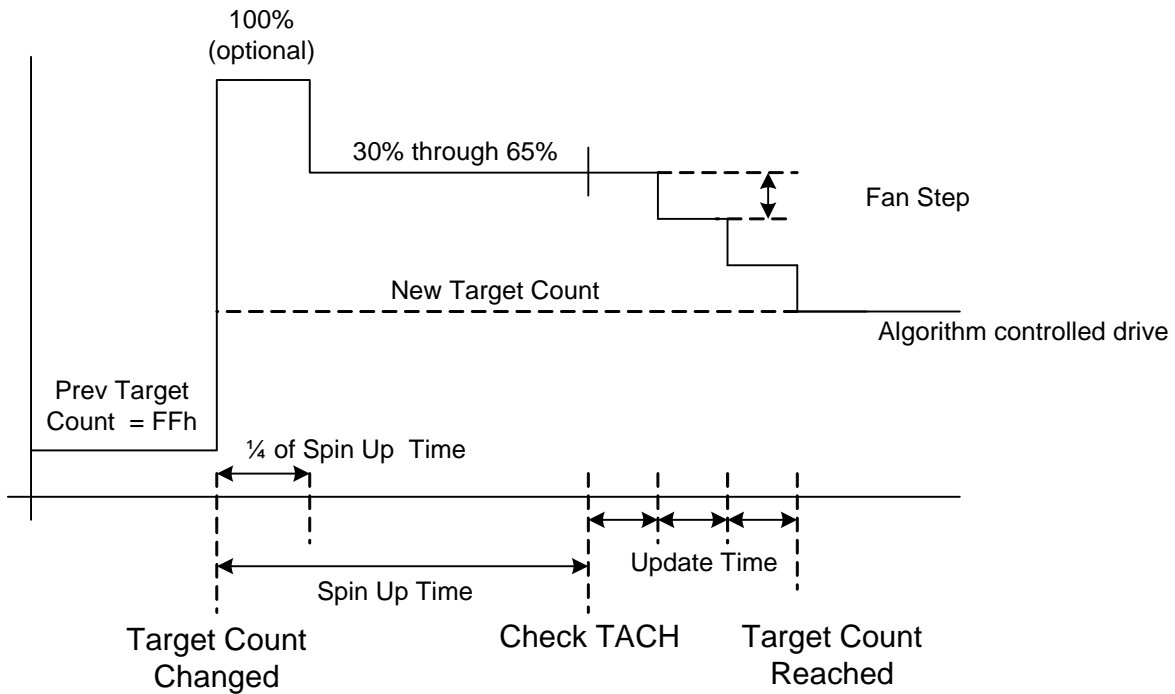
Figure 5.2 Spin Up Routine

5.5 Ramp Rate Control

The Fan Driver can be configured with automatic ramp rate control. Ramp rate control is accomplished by adjusting the drive output settings based on the Maximum Fan Step Register settings and the Update Time settings.

If the RPM-based Fan Speed Control Algorithm is used, then this ramp rate control is automatically used. The user programs a maximum step size for the fan drive setting and an update time. The update time varies from 100ms to 1.6s while the fan drive maximum step can vary from 1 count to 31 counts.

When a new fan drive setting is entered, the delta from the next fan drive setting and the previous fan drive setting is determined. If this delta is greater than the Max Step settings, then the fan drive setting is incrementally adjusted every 100ms to 1.6s as determined by the Update Time until the target fan drive setting is reached. See [Figure 5.3](#).

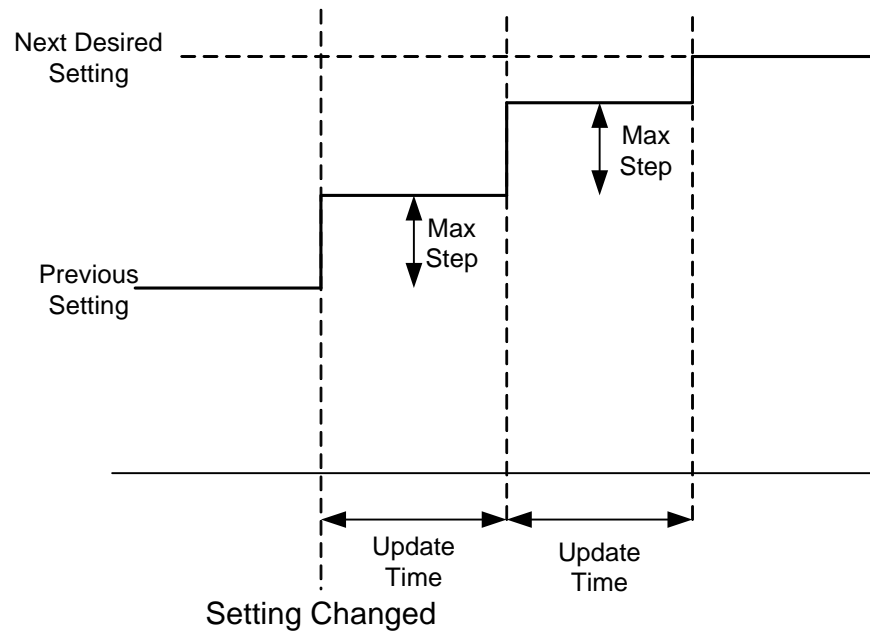

Figure 5.3 Ramp Rate Control

5.5.1 Temperature Bypass of Ramp Rate Control

As an optional feature, the Ramp Rate Control functionality can be disabled if any of the measured temperature channels exceed their respective high limits. In this mode, once the high limit has been exceeded, the ramp rate controls are removed which allows the fan to move instantly to the programmed drive setting (using the FSC or in manual mode).

5.6 Watchdog Timer

The EMC2112 contains an internal Watchdog Timer for the fan driver. The Watchdog timer monitors the SMBus traffic for signs of activity and works in two different modes based upon device operation. These modes are Power Up Operation and Continuous Operation as described below.

For either mode of operation, if four (4) seconds elapse without activity detected by the host, then the watchdog will be triggered and the following will occur:

1. The WATCH status bit will be set which will cause the $\overline{\text{ALERT}}$ pin to be asserted.
2. The fan driver will be set to full scale drive. It will remain at full scale drive until it is disabled.

APPLICATION NOTE: When the Watchdog timer is activated the Fan Speed Control Algorithm is automatically disabled. Disabling the Watchdog will not automatically set the fan drive nor re-activate the Fan Speed Control Algorithm. This must be done manually.

5.6.1 Power Up Operation

The Watchdog Timer only starts immediately after power-up and once it has been triggered or deactivated will not restart (however can be configured to operate in Continuous operation)

In the Power Up Operation, the Watchdog Timer is disabled by any of the following actions:

1. Writing the Fan Setting Register will disable the Watchdog Timer.
2. Enabling the RPM-based Fan Speed Control Algorithm by setting the EN_ALGO bit will disable the Watchdog Timer. The fan driver will be set based on the RPM-based Fan Speed Control Algorithm.
3. Changing the Watchdog operating mode by setting the WD_EN bit.

Writing any other configuration registers will not disable the Watchdog Timer upon power up.

5.6.2 Continuous Operation

When configured to operate in Continuous Operation, the Watchdog timer will start immediately. It can be disabled by any access (read or write) to the SMBus register set. Upon completion of SMBus activity, the Watchdog timer is reset and restarted.

5.7 High Side Fan Driver

The EMC2112's integrates a 5V, 600mA, linear high side fan driver to directly drive a 5V fan. By fully integrating the linear fan driver, the typical requirement for the discrete pass device and other external linearization circuitry is completely eliminated.

5.7.1 Overcurrent Limit

The High Side Fan Driver contains circuitry to allow for significant over current levels to accommodate transient conditions on the FAN pins. The over current limit is dependent upon the output voltage with the limit dropping as the voltage nears 0V.

If the fan driver current detects a short-circuit condition for longer than 2 seconds, then the I_SHORT status bit is set and an interrupt generated. Additionally, the High Side Fan Driver will be disabled for 8 seconds. After this 8 second time has elapsed, it will be allowed to restart invoking the Spin Up Routine before returning to its previous drive setting.

APPLICATION NOTE: If the FSC Algorithm is active, then it will generate errant SPIN_FAIL interrupts during the 8 second time that the fan driver is held off.

5.8 Internal Thermal Shutdown (TSD)

The EMC2112 contains an internal thermal shutdown circuit that monitors the internal die temperature. If the die temperature exceeds the Thermal Shutdown Threshold (see [Table 3.2](#)), then the following will occur:

1. The High Side Fan Driver is disabled. It will remain disabled until the internal temperature drops below the threshold temperature minus 50°C.
2. The TSD Status bit is set.
3. The $\overline{\text{SYS_SHDN}}$ pin is asserted.

5.9 Critical/Thermal Shutdown

The EMC2112 provides a hardware Critical/Thermal Shutdown function for systems. [Figure 5.4](#) is a block diagram of this Critical/Thermal Shutdown function. The Critical/Thermal Shutdown function in

Datasheet

the EMC2112 consists of both analog and digital functions. It accepts configuration information from the fixed states of the SHDN_SEL pin as described in [Section 5.9.2](#).

Each of the temperature limits can be configured to act as inputs to the Critical / Thermal Shutdown independent of the hardware shutdown operation.

The analog portion of the Critical/Thermal Shutdown function monitors a specific remote temperature channel (configured with the SHDN_SEL pin). This measured temperature is then compared with the TRIP_SET point. This TRIP_SET point is created by the system designer with a simple resistor and is discussed in detail in [Section 5.9.1](#).

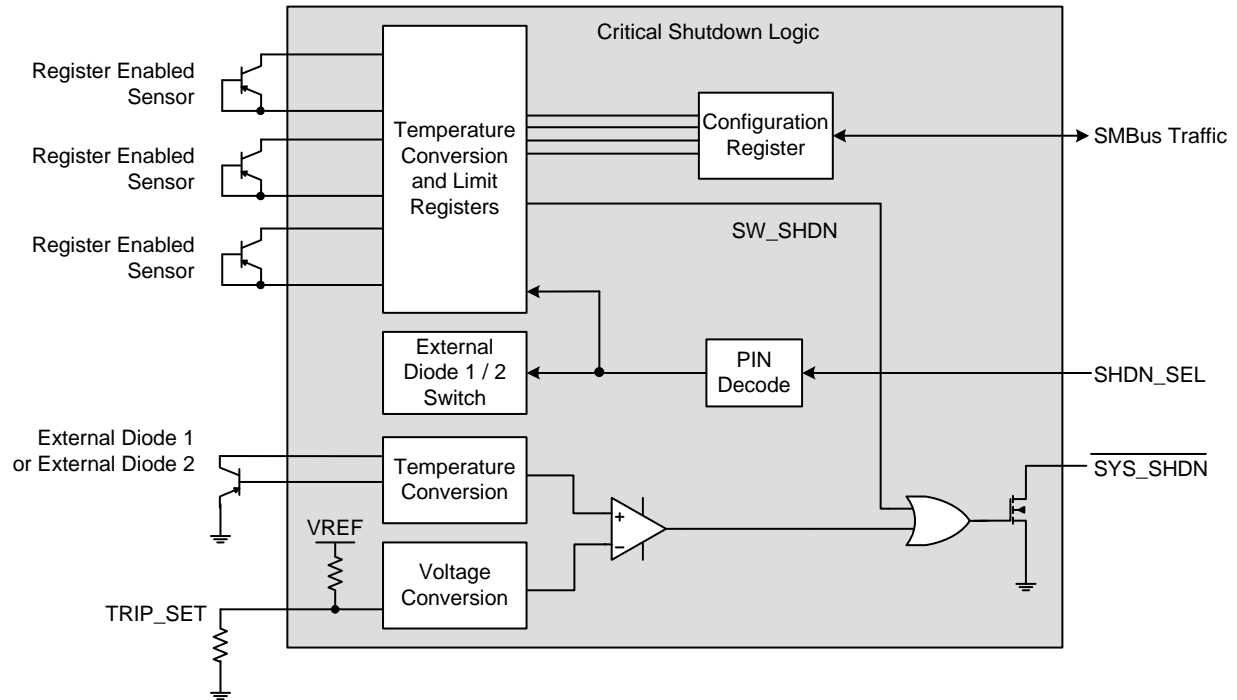

Figure 5.4 EMC2112 Critical/Thermal Shutdown Block Diagram

5.9.1 TRIP_SET Pin

The EMC2112's TRIP_SET pin is an analog input to the Critical/Thermal Shutdown block which sets the Thermal Shutdown temperature. The system designer creates a voltage level at the input through a simple resistor connected to GND as shown in [Figure 5.1](#). The value of this resistor is used to create an input voltage on the TRIP_SET pin which is translated into a temperature ranging from 60°C to 122°C enumerated in [Table 5.2](#).

$$V_{TRIP} = \frac{T_{TRIP} - T_{MIN}}{80}$$

V_{TRIP} is the TRIP_SET voltage

T_{MIN} is the minimum temperature based on the range

[1]

Table 5.2 TRIP_SET Resistor Setting

T_{TRIP} (°C)	RSET (1%)	T_{TRIP} (°C)	RSET (1%)
60	0.0	92	1240
61	28.7	93	1330
62	48.7	94	1400
63	69.8	95	1500
64	90.9	96	1580
65	113	97	1690
66	137	98	1820
67	158	99	1960
68	182	100	2050
69	210	101	2210
70	237	102	2370
71	261	103	2550
72	294	104	2740
73	324	105	2940
74	348	106	3160
75	383	107	3480
76	412	108	3740
77	453	109	4120
78	487	110	4530
79	523	111	4990
80	562	112	5490
81	604	113	6040
82	649	114	6810
83	698	115	7870
84	750	116	9090
85	787	117	10700
86	845	118	12700
87	909	119	15800
88	953	120	20500

Table 5.2 TRIP_SET Resistor Setting (continued)

T _{TRIP} (°C)	RSET (1%)	T _{TRIP} (°C)	RSET (1%)
89	1020	121	29400
90	1100	122	49900
91	1150	60	Open

5.9.2 SHDN_SEL Pin

The EMC2112 has one ‘strappable’ input (SHDN_SEL) allowing for configuration of the hardware Critical/Thermal Shutdown. This pin has 3 possible states and is monitored and decoded by the EMC2112 at power-up. The three possible states are 0 (tied to GND), 1 (tied to 3.3V) or High-Z (open). The states of this pin determine which remote temperature channel and configuration is used by the Critical/Thermal Shutdown function. The different configurations of SHDN_SEL pin are described in [Table 5.3](#)

A channel that is configured via the SHDN_SEL pin for the Critical/Thermal Shutdown is locked and none of the configuration registers associated with it can be updated via the SMBus. The other two temperature channels, however, are still configurable via the SMBus.

Table 5.3 SHDN_SEL Pin Configuration

SHDN_SEL	FUNCTION NAME	CRITICAL/THERMAL SHUTDOWN DETAILS
‘0’	Intel Transistor Mode (substrate PNP)	The external diode 1 channel is configured with Beta Compensation enabled and Resistance Error Correction enabled (with automatic detection). This mode is ideal for monitoring a substrate transistor such as an Intel CPU thermal diode.
High-Z (open)	AMD CPU / Diode Mode	The external diode 1 channel is configured with Beta Compensation disabled and Resistance Error Correction disabled. This mode is ideal for monitoring an AMD processor diode or a 2N3904 diode.
‘1’	External Diode 2 Diode Mode	The External Diode 2 channel is linked to the Hardware set Thermal / Critical shutdown circuitry and configured with Beta Compensation enabled (with automatic detection) and REC enabled.

5.9.3 Internal HW_SHDN Signal

The HW_SHDN output from the Critical/Thermal Shutdown Monitor is a logical indicator of the temperature state of the chosen external diode channel. HW_SHDN is an internal signal routed as an input to the Thermal / Critical Shutdown logic.

The HW_SHDN output is set to logic ‘1’ when the indicated temperature exceeds the temperature threshold (T_p) established by the TRIP_SET input pin (as shown in [Figure 5.5](#)) for a number of consecutive measurements defined by the fault queue. If the HW_SHDN output is asserted and the temperature drops below T_p, then it will be set to a logic ‘0’ state.

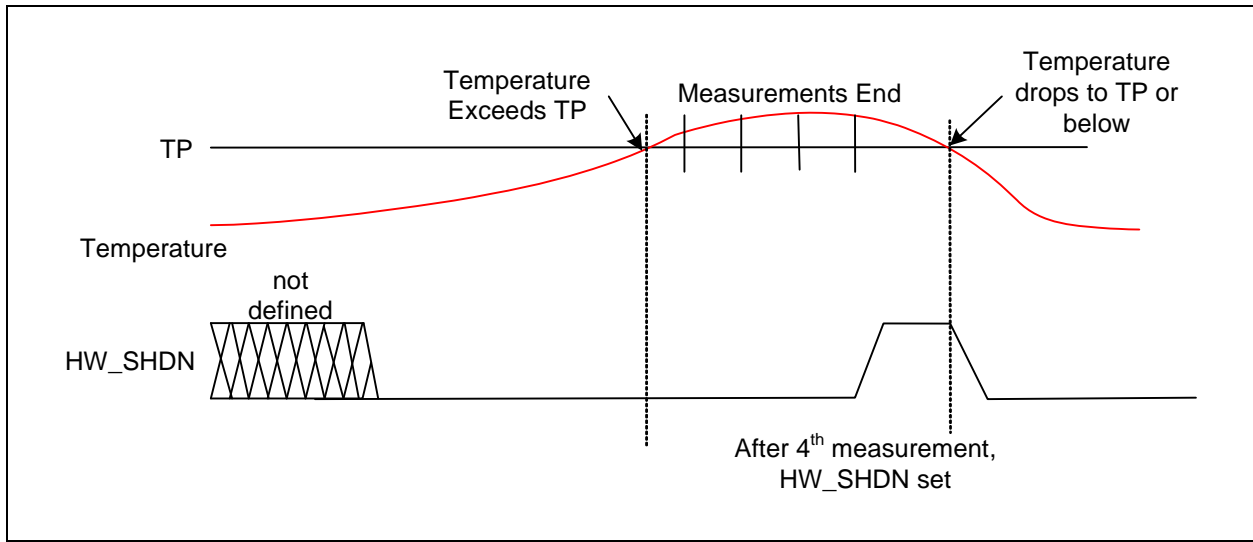
Figure 5.5 HW_SHDN Operation

5.10 5V Reset Controller

The EMC2112 also provides a 'power-good' reset controller for the system's 5V supply rail. The reset controller will set the $\overline{\text{RESET}}$ pin to a logic '0' after power-up and set the $\overline{\text{RESET}}$ pin to a logic '1' 220ms after the VDD_5V supply rises above its threshold voltage (see [Table 3.2](#)).

If the VDD_5V supply drops below the reset threshold, the $\overline{\text{RESET}}$ pin will be set to '0' immediately.

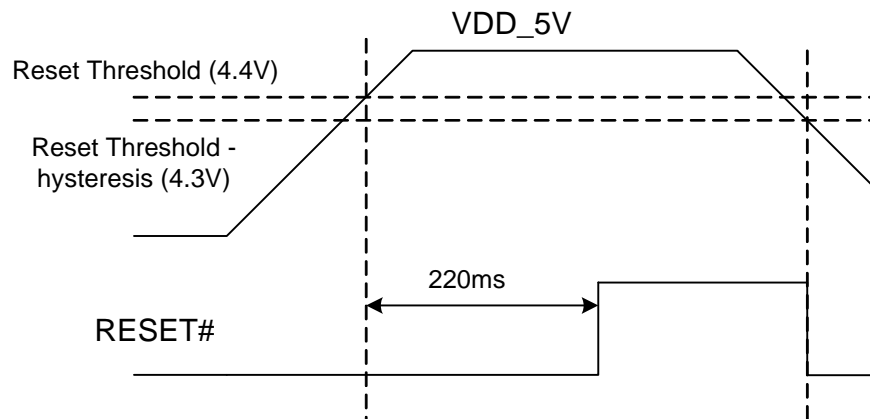
Figure 5.6 5V Reset Controller Timing

5.11 Temperature Monitoring

The EMC2112 can monitor the temperature of up to three (3) externally connected diodes as well as the internal or ambient temperature. Each channel is configured with the following features enabled or disabled based on user settings and system requirements.

5.11.1 Dynamic Averaging

The EMC2112 supports dynamic averaging. When enabled, this feature changes the conversion time for all external diode channels based on the selected conversion rate. This essentially increases the averaging factor as shown in [Table 5.4](#). The benefits of Dynamic Averaging are improved noise rejection due to the longer integration time as well as less random variation on the temperature measurement.

Table 5.4 Dynamic Averaging Behavior

CONVERSION RATE	AVERAGING FACTOR (RELATIVE TO 11-BIT CONVERSION) FOR EXTERNAL DIODE CHANNELS	
	DYNAMIC AVERAGING ENABLED	DYNAMIC AVERAGING DISABLED
1 / sec	8x	1x
2 / sec	4x	1x
4 / sec	2x	1x
8 / sec	1x	1x

5.11.2 Resistance Error Correction

The EMC2112 includes active Resistance Error Correction to remove the effect of up to 100 ohms of series resistance. Without this automatic feature, voltage developed across the parasitic resistance in the remote diode path causes the temperature to read higher than the true temperature is. The error induced by parasitic resistance is approximately +0.7°C per ohm. Sources of parasitic resistance include bulk resistance in the remote temperature transistor junctions, series resistance in the CPU, and resistance in the printed circuit board traces and package leads. Resistance error correction in the EMC2112 eliminates the need to characterize and compensate for parasitic resistance in the remote diode path.

5.11.3 Beta Compensation

The forward current gain, or beta, of a transistor is not constant as emitter currents change. This beta variation causes the measured V_{BE} (which is related to the collector current which, in turn, is related to beta) to shift in a way that is not predicted by the ratio of emitter currents being forced into the device. This shift cause an error in the temperature measurement. Compensating for this error is also known as implementing the BJT or transistor model for temperature measurement.

For discrete transistors configured with the collector and base shorted together, the beta is generally sufficiently high such that the percent change in beta variation is very small. For example, a 10% variation in beta for two forced emitter currents with a transistor whose ideal beta is 50 would contribute approximately 0.25°C error at 100°C. However for substrate transistors where the base-emitter junction is used for temperature measurement and the collector is tied to the substrate, the proportional beta variation will cause large error. For example, a 10% variation in beta for two forced emitter currents with a transistor whose ideal beta is 0.5 would contribute approximately 8.25°C error at 100°C.

The Beta Compensation circuitry in the EMC2112 corrects for this beta variation to eliminate any error which would normally be induced. This Beta Compensation circuitry automatically detects the type of diode connected and adjusts the beta settings accordingly.

5.11.4 Digital Averaging

The External Diode 1 channel support a 4x digital averaging filter. Every cycle, this filter updates the temperature data based on a running average of the last 4 measured temperature values. The digital averaging reduces temperature flickering and increases temperature measurement stability.

The digital averaging can be disabled by setting the DIS_AVG bit in the Configuration 2 Register (see [Section 6.10](#)).

5.12 Diode Connections

The diode connection for the External Diode 1 and External Diode 2 channels are determined at power-up based on the SHDN_SEL pin (see [Section 5.9.2](#)). This channel can support a diode-connected transistor (such as a 2N3904) or a substrate transistor (such as those found in a CPU or GPU) as shown in [Figure 5.7](#).

The External Diode 3 channel is available when the External Diode 2 channel is configured to operate as an anti-parallel diode pair. In this mode, both the External Diode 2 and External Diode 3 diodes must be connected in the anti-parallel configuration as shown in [Figure 5.7](#)

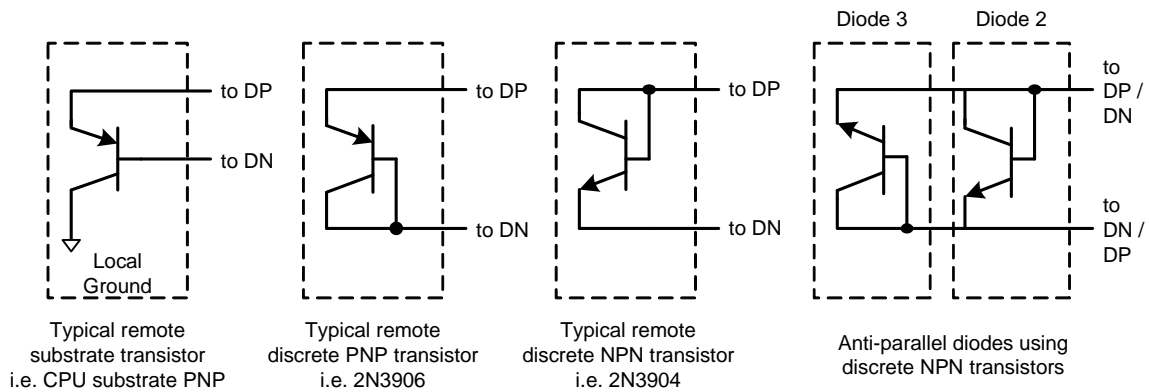

Figure 5.7 Diode Connections

5.12.1 Diode Faults

The EMC2112 actively detects an open and short condition on each measurement channel. When a diode fault is detected, the temperature data most significant byte is forced to a value of 80h and the FAULT bit is set in the Status Register.

Chapter 6 Register Set

6.1 Register Map

The following registers are accessible through the SMBus Interface. All register bits marked as '-' will always read '0'. A write to these bits will have no effect.

Table 6.1 EMC2112 Register Set

ADDR	R/W	REGISTER NAME	FUNCTION	DEFAULT VALUE	LOCK	PAGE
Temperature Registers						
00h	R	Internal Temp Reading High Byte	Stores the integer data of the Internal Diode	00h	No	Page 36
01h	R	Internal Temp Reading Low Byte	Stores the fractional data of the Internal Diode	00h	No	Page 36
02h	R	External Diode 1 Temp Reading High Byte	Stores the integer data of External Diode 1 channel	00h	No	Page 36
03h	R	External Diode 1 Temp Reading Low Byte	Stores the fractional data of External Diode 1	00h	No	Page 36
04h	R	External Diode 2 Temp Reading High Byte	Stores the integer data of External Diode 2 channel	00h	No	Page 36
05h	R	External Diode 2 Temp Reading Low Byte	Stores the fractional data of External Diode 2	00h	No	Page 36
06h	R	External Diode 3 Temp Reading High Byte	Stores the integer data of External Diode 3 channel	00h	No	Page 36
07h	R	External Diode 3 Temp Reading Low Byte	Stores the fractional data of External Diode 3	00h	No	Page 36
0Ah	R	Critical/Thermal Shutdown Temperature	Stores the calculated Critical/Thermal Shutdown temperature high limit derived from the voltage on TRIP_SET	7Fh (+127°C)	No	Page 37
10h	R	Trip Set Voltage	Stores the raw measured TRIP_SET voltage input	FFh	No	Page 38
Diode Configuration						
11h	R/W	External Diode 1 Ideality	Configures Ideality Factor settings for External Diode 1	12h	SWL	Page 38
12h	R/W	External Diode 2 Ideality	Configures Ideality Factor settings for External Diode 2	12h	SWL	Page 38
13h	R/W	External Diode 3 Ideality	Configures Ideality Factor settings for External Diode 3	12h	SWL	Page 38

Table 6.1 EMC2112 Register Set (continued)

ADDR	R/W	REGISTER NAME	FUNCTION	DEFAULT VALUE	LOCK	PAGE
14h	R/W	External Diode 1 Beta Configuration	Configures the beta compensation settings for External Diode 1	10h	SWL	Page 39
15h	R/W	External Diode 2 Beta Configuration	Configures the beta compensation settings for External Diode 2	10h	SWL	Page 39
17h	R/W	External Diode REC Configuration	Configures the Resistance Error Correction functionality for all external diodes	07h	SWL	Page 41
19h	R/W	External Diode 1 Tcrit Limit	Stores the Critical temperature limit for the External Diode 1	64h (100°C)	Write Lock	Page 41
1Ah	R/W	External Diode 2 Tcrit Limit	Stores the Critical temperature limit for the External Diode 2	64h (100°C)	Write Lock	Page 41
1Bh	R/W	External Diode 3 Tcrit Limit	Stores the Critical temperature limit for the External Diode 3	64h (100°C)	Write Lock	Page 41
1Dh	R/W	Internal Diode Tcrit Limit	Stores the Critical temperature limit for the Internal Diode	64h (100°C)	Write Lock	Page 41
Configuration and Control						
1Fh	R-C	Tcrit Limit Status	Stores the status bits for all temperature channel Tcrit limits	00h	No	Page 45
20h	R/W	Configuration	Configures the Thermal / Critical Shutdown masking options and software lock	00h	SWL	Page 42
21h	R/W	Configuration 2	Controls the conversion rate for monitoring of all channels	0Eh	SWL	Page 43
23h	R-C	Interrupt Status	Stores the status bits for temperature channels	00h	No	Page 44
24h	R-C	High Limit Status	Stores the status bits for all temperature channel high limits	00h	No	Page 45
26h	R-C	Diode Fault	Stores the status bits for all temperature channel diode faults	00h	No	Page 45
27h	R-C	Fan Status	Stores the status bits for the RPM-based Fan Speed Control Algorithm	00h	No	Page 46
28h	R/W	Interrupt Enable Register	Controls the masking of interrupts on all temperature channels	00h	No	Page 46
29h	R/W	Fan Interrupt Enable Register	Controls the masking of interrupts on all fan related channels	00h	No	Page 47
Temperature Limit Registers						
30h	R/W	External Diode 1 Temp High Limit	High limit for External Diode 1	55h (+85°C)	SWL	Page 47
31h	R/W	External Diode 2 Temp High Limit	High limit for External Diode 2	55h (+85°C)	SWL	Page 47

Table 6.1 EMC2112 Register Set (continued)

ADDR	R/W	REGISTER NAME	FUNCTION	DEFAULT VALUE	LOCK	PAGE
32h	R/W	External Diode 3 Temp High Limit	High limit for External Diode 3	55h (+85°C)	SWL	Page 47
34h	R/W	Internal Diode High Limit	High Limit for Internal Diode	55h (85°C)	SWL	Page 47
Fan Control Registers						
40h	R/W	Fan Setting	Always displays the most recent fan driver input setting for the Fan. If the RPM-based Fan Speed Control Algorithm is disabled, allows direct user control of the fan driver.	00h	No	Page 48
42h	R/W	Fan Configuration 1	Sets configuration values for the RPM-based Fan Speed Control Algorithm for the Fan driver	2Bh	No	Page 48
43h	R/W	Fan Configuration 2	Sets additional configuration values for the Fan driver	28h	SWL	Page 50
45h	R/W	Gain	Holds the gain terms used by the RPM-based Fan Speed Control Algorithm for the Fan driver	2Ah	SWL	Page 51
46h	R/W	Fan Spin Up Configuration	Sets the configuration values for Spin Up Routine of the Fan driver	19h	SWL	Page 52
47h	R/W	Fan Step	Sets the maximum change per update for the Fan driver	10h	SWL	Page 53
48h	R/W	Fan Minimum Drive	Sets the minimum drive value for the Fan driver	66h (40%)	SWL	Page 54
49h	R/W	Fan Valid TACH Count	Holds the minimum tachometer reading that indicates the fan is spinning properly	F5h	SWL	Page 54
4Ah	R/W	Fan Drive Fail Band Low Byte	Stores the number of Tach counts used to determine how the actual fan speed must match the target fan speed at full scale drive	00h	SWL	Page 55
4Bh	R/W	Fan Drive Fail Band High Byte		00h	SWL	
4Ch	R/W	TACH Target Low Byte	Holds the target tachometer reading low byte for the Fan	F8h	No	Page 55
4Dh	R/W	TACH Target High Byte	Holds the target tachometer reading high byte for the Fan	FFh	No	Page 55
4Eh	R	TACH Reading High Byte	Holds the tachometer reading high byte for the Fan	FFh	No	Page 55
4Fh	R	TACH Reading Low Byte	Holds the tachometer reading low byte for the Fan	F8h	No	Page 55
Lock Register						
EF	R/W	Software Lock	Locks all SWL registers	00h	SWL	Page 56

Table 6.1 EMC2112 Register Set (continued)

ADDR	R/W	REGISTER NAME	FUNCTION	DEFAULT VALUE	LOCK	PAGE
Revision Registers						
FCh	R	Product Features	Stores information about which pin controlled product features are set	00h	No	Page 57
FDh	R	Product ID	Stores the unique Product ID	15h	No	Page 57
FEh	R	Manufacturer ID	Stores the Manufacturer ID	5Dh	No	Page 58
FFh	R	Revision	Revision	01h	No	Page 58

During Power-On-Reset (POR), the default values are stored in the registers. A POR is initiated when power is first applied to the part and the voltage on the VDD_3V supply surpasses the POR level as specified in the electrical characteristics. Any reads to undefined registers will return 00h. Writes to undefined registers will not have an effect.

6.1.1 Lock Entries

The Lock Column describes the locking mechanism, if any, used for individual registers. All SWL registers are Software Locked and therefore made read-only when the LOCK bit is set.

6.2 Temperature Data Registers

Table 6.2 Temperature Data Registers

ADDR	R/W	REGISTER	B7	B6	B5	B4	B3	B2	B1	B0	DEFAULT
00h	R	Internal Diode High Byte	Sign	64	32	16	8	4	2	1	00h
01h	R	Internal Diode Low Byte	0.5	0.25	0.125	-	-	-	-	-	00h
02h	R	External Diode 1 High Byte	Sign	64	32	16	8	4	2	1	00h
03h	R	External Diode 1 Low Byte	0.5	0.25	0.125	-	-	-	-	-	00h
04h	R	External Diode 2 High Byte	Sign	64	32	16	8	4	2	1	00h
05h	R	External Diode 2 Low Byte	0.5	0.25	0.125	-	-	-	-	-	00h
06h	R	External Diode 3 High Byte	Sign	64	32	16	8	4	2	1	00h
07h	R	External Diode 3 Low Byte	0.5	0.25	0.125	-	-	-	-	-	00h

Datasheet

The temperature measurement range is from -64°C to +128°C. The data format is a signed two's complement number as shown in [Table 6.3](#).

APPLICATION NOTE: When the External Diode 3 channel is not enabled, the data bytes will read 00h.

Table 6.3 Temperature Data Format

TEMPERATURE (°C)	BINARY	HEX (AS READ BY REGISTERS)
Diode Fault	1000_0000_000b	80_00h
-63.875	1100_0000_001b	C0_20h
-63	1100_0001_000b	C1_00h
-1	1111_1111_000b	FF_00h
-0.125	1111_1111_111b	FF_E0h
0	0000_0000_000b	00_00h
0.125	0000_0000_001b	00_20h
1	0000_0001_000b	01_00h
63	0011_1111_000b	3F_00h
64	0100_0000_000b	40_00h
65	0100_0001_000b	41_00h
127	0111_1111_000b	7F_00h
127.875	0111_1111_111b	7F_E0h

6.3 Critical/Thermal Shutdown Temperature Registers

Table 6.4 Critical/Thermal Shutdown Temperature Registers

ADDR	R/W	REGISTER	B7	B6	B5	B4	B3	B2	B1	B0	DEFAULT
0Ah	R	Critical/Thermal Shutdown Temperature	-	64	32	16	8	4	2	1	7Fh (+127°C)

The Critical/Thermal Shutdown Temperature Register is a read-only register that stores the Voltage Programmable Threshold temperature used in the Thermal / Critical Shutdown circuitry. The contents of the register reflect the calculated temperature based on the TRIP_SET voltage. This register is updated at the end of every monitoring cycle based on the current value of the TRIP_SET voltage.

The data format is shown in [Table 6.5](#).

Table 6.5 Critical / Thermal Shutdown Data Format

TEMPERATURE (°C)	BINARY	HEX
0	0000_0000b	00h
1	0000_0001b	01h

Table 6.5 Critical / Thermal Shutdown Data Format (continued)

TEMPERATURE (°C)	BINARY	HEX
63	0011_1111b	3Fh
64	0100_0000b	40h
65	0100_0001b	41h
127	0111_1111b	7Fh

6.4 TripSet Voltage Register

Table 6.6 TripSet Voltage Register

ADDR	R/W	REGISTER	B7	B6	B5	B4	B3	B2	B1	B0	DEFAULT
10h	R	TripSet Voltage	400	200	100	50	25	12.5	6.25	3.125	FFh

The TripSet Voltage Register stores the measured voltage on the TRIP_SET pin that is used to calculate the Critical / Thermal Shutdown temperature. Each bit weight represents mV of resolution so that the final voltage can be determined by adding the appropriately set bits together.

6.5 Ideality Factor Registers

Table 6.7 Ideality Factor Registers

ADDR	R/W	REGISTER	B7	B6	B5	B4	B3	B2	B1	B0	DEFAULT
11h	R/W	External Diode 1 Ideality	0	0	0	1	0	B2	B1	B0	12h
12h	R/W	External Diode 2 Ideality	0	0	0	1	0	B2	B1	B0	12h
13h	R/W	External Diode 3 Ideality	0	0	0	1	0	B2	B1	B0	12h

These registers store the ideality factors that are applied to the external diodes.

Beta Compensation and Resistance Error Correction automatically correct for most diode ideality errors, therefore it is not recommended that these settings be updated without consulting SMSC.

For CPU substrate transistors that require the BJT transistor model, the ideality factor behaves slightly differently than for discrete diode-connected transistors. Refer to [Table 6.9](#) when using a CPU substrate transistor.

Only the lower three bits can be written. Writing to any other bit will be ignored.

The Ideality Factor Registers are software locked.

Table 6.8 Ideality Factor Look-Up Table

SETTING	FACTOR
10h	1.0053
11h	1.0066
12h	1.0080
13h	1.0093
14h	1.0106
15h	1.0119
16h	1.0133
17h	1.0146

Table 6.9 Substrate Diode Ideality Factor Look-Up Table (BJT Model)

SETTING	FACTOR
10h	0.9973
11h	0.9986
12h	1.0000
13h	1.0013
14h	1.0026
15h	1.0039
16h	1.0053
17h	1.0066

APPLICATION NOTE: When measuring a 65nm Intel CPUs, the Ideality Setting should be the default 12h. When measuring 45nm Intel CPUs, the Ideality Setting should be 15h.

6.6 Beta Configuration Registers

Table 6.10 Beta Configuration Registers

ADDR	R/W	REGISTER	B7	B6	B5	B4	B3	B2	B1	B0	DEFAULT
14h	R/W	External Diode 1 Beta Configuration	-	-	-	AUTO 1	BETA1[3:0]			10h	
15h	R/W	External Diode 2 Beta Configuration	-	-	-	AUTO 2	BETA2[3:0]			10h	

The Beta Configuration Registers control advanced temperature measurement features for each External Diode channel. The Beta Configuration Registers are software locked. The External Diode 1 Beta Configuration register is hardware locked if the External Diode 1 channel is linked to the hardware Critical / Thermal shutdown circuitry. Likewise, the External Diode 2 Beta Configuration register is hardware locked if the External Diode 2 is linked to the Critical / Thermal shutdown circuitry - see [Section 5.9.2](#).

Bit 4 - AUTO - Enables the Automatic Beta detection algorithm.

- '0' - The Automatic Beta detection algorithm is disabled. The BETAx[3:0] bit settings will be used to control the beta compensation circuitry.
- '1' (default) - The Automatic Beta detection algorithm is enabled. The circuitry will automatically detect the transistor type and beta values and configure the BETAx[3:0] bits for optimal performance.

Bits 3 - 0 - BETAx[3:0] - hold a value that corresponds to a range of betas that the Beta Compensation circuitry can compensate for. These four bits will always show the current beta setting used by the circuitry. If the AUTO bit is set (default), then these bits may be updated by the device with every temperature conversion. If the AUTO bit is not set, then the value of these bits is used to drive the beta compensation circuitry. In this case, these bits should be set with a value corresponding to the lowest expected value of beta for the PNP transistor being used as a temperature sensing device.

See [Table 6.11](#) for supported beta ranges. A value of 1111b indicates that the beta compensation circuitry is disabled. In this condition, the diode channels will function with default current levels and will not automatically adjust for beta variation. This mode is used when measuring a discrete 2N3904 transistor or AMD thermal diode.

All of the Beta Configuration Registers are Software Locked.

Table 6.11 Beta Compensation

AUTO	BETAX[3:0]				MINIMUM BETA
	3	2	1	0	
0	0	0	0	0	0.050
0	0	0	0	1	0.066
0	0	0	1	0	0.087
0	0	0	1	1	0.114
0	0	1	0	0	0.150
0	0	1	0	1	0.197
0	0	1	1	0	0.260
0	0	1	1	1	0.342
0	1	0	0	0	0.449
0	1	0	0	1	0.591
0	1	0	1	0	0.778
0	1	0	1	1	1.024
0	1	1	0	0	1.348
0	1	1	0	1	1.773

Table 6.11 Beta Compensation (continued)

AUTO	BETAX[3:0]				MINIMUM BETA
	3	2	1	0	
0	1	1	1	0	2.333
0	1	1	1	1	Disabled
1	X	X	X	X	Automatically detected

6.7 REC Configuration Register

Table 6.12 REC Configuration Register

ADDRESS	R/W	REGISTER	B7	B6	B5	B4	B3	B2	B1	B0	DEFAULT
17h	R/W	REC Configuration	-	-	-	-	-	REC3	REC2	REC1	07h

The REC Configuration Register determines whether Resistance Error Correction is used for each external diode channel. The REC Configuration Register is software locked.

If either the External Diode 1 channel or External Diode 2 channel is selected by the SHDN_SEL pin to be the hardware shutdown input channel (see [Table 5.3](#)), then the corresponding RECx bit will be locked. Writing to the bit will have no affect and reading from it will always report the current setting.

Bit 2 - REC3 - Controls the Resistive Error Correction functionality of External Diode 3

- '0' - the REC functionality for External Diode 3 is disabled
- '1' (default) - the REC functionality for External Diode 3 is enabled.

Bit 1 - REC2 - Controls the Resistive Error Correction functionality of External Diode 2

- '0' - the REC functionality for External Diode 2 is disabled
- '1' (default) - the REC functionality for External Diode 2 is enabled.

Bit 0 - REC1 - Controls the Resistive Error Correction functionality of External Diode 1

- '0' - the REC functionality for External Diode 1 is disabled
- '1' (default) - the REC functionality for External Diode 1 is enabled.

6.8 Critical Temperature Limit Registers

Table 6.13 Tcrit Limit Registers

ADDR	R/W	REGISTER	B7	B6	B5	B4	B3	B2	B1	B0	DEFAULT
19h	R/W once	External Diode 1 Tcrit Limit	Sign	64	32	16	8	4	2	1	64h (+100°C)
1Ah	R/W once	External Diode 2 Tcrit Limit	Sign	64	32	16	8	4	2	1	64h (+100°C)

Table 6.13 Tcrit Limit Registers (continued)

ADDR	R/W	REGISTER	B7	B6	B5	B4	B3	B2	B1	B0	DEFAULT
1Bh	R/W once	External Diode 2 Tcrit Limit	Sign	64	32	16	8	4	2	1	64h (+100°C)
1Dh	R/W once	Internal Diode Tcrit Limit	Sign	64	32	16	8	4	2	1	64h (+100°C)

The Critical Temperature Limit Registers store the Critical Temperature Limit. At power up, none of the respective channels are linked to Hardware set Thermal/Critical Shutdown circuitry.

Whenever one of the registers is updated, two things occur. First, the register is locked so that it cannot be updated again without a power on reset. Second, the respective temperature channel is linked to the SYS_SHDN pin and the Hardware set Thermal/Critical Shutdown Circuitry. At this point, if the measured temperature channel exceeds the Critical limit, the SYS_SHDN pin will be asserted, the appropriate bit set in the Tcrit Status Register, and the TCRIT bit in the Interrupt Status Register will be set.

6.9 Configuration Register

Table 6.14 Configuration Register

ADDR	R/W	REGISTER	B7	B6	B5	B4	B3	B2	B1	B0	DEFAULT
20h	R/W	Configuration	MASK	WD_ EN	-	-	-	DR_ EXT_ CLK	USE_ EXT_ CLK	APD	00h

The Configuration Register controls the basic functionality of the EMC2112. The bits are described below. The Configuration Register is software locked.

Bit 7 - MASK - Blocks the $\overline{\text{ALERT}}$ pin from being asserted.

- '0' (default) - The $\overline{\text{ALERT}}$ pin is unmasked. If any bit in either status register is set, the $\overline{\text{ALERT}}$ pins will be asserted (unless individually masked via the Mask Register)
- '1' - The $\overline{\text{ALERT}}$ pin is masked and will not be asserted.

Bit 6 - WD_EN - Enables the Watchdog timer to operate in Continuous Mode (see [Section 5.6.2](#)).

- '0' (default) - The Watchdog timer does not operate continuously. It will function upon power up and at no other time.
- '1' - The Watchdog timer operates continuously as described in [Section 5.6](#).

Bit 2 - DR_EXT_CLK - Enables the internal tachometer clock to be driven out on the CLK pin so that multiple devices can be synced to the same source.

- '0' (default) - The CLK pin acts as a clock input.
- '1' - The CLK pin acts as a clock output and is a push-pull driver.

Bit 1 - USE_EXT_CLK - Enables the EMC2112 to use a clock present on the CLK pin as the tachometer clock. If the DR_EXT_CLK bit is set, then this bit is ignored and the device will use the internal oscillator.

- '0' (default) - The EMC2112 will use its internal oscillator for all Tachometer measurements.
- '1' - The EMC2112 will use the oscillator presented on the CLK pin for all Tachometer measurements.

Datasheet

Bit 0 - APD - Enables the External Diode 3 channel.

- '0' (default) - The External Diode 3 channel is not enabled.
- '1' - The External Diode 3 channel is enabled as an anti-parallel diode connected to DP2 / DN2 pins.

6.10 Configuration 2 Register

Table 6.15 Configuration 2 Register

ADDR	R/W	REGISTER	B7	B6	B5	B4	B3	B2	B1	B0	DEFAULT
21h	R/W	Config 2	-	DIS_DYN	DIS_TO	DIS_AVG	QUEUE[1:0]		CONV[1:0]		0Eh

The Configuration 2 Register controls conversion rate of the temperature monitoring as well as the fault queue. This register is software locked.

Bit 6 - DIS_DYN - Disables the Dynamic Averaging Feature.

- '0' (default) - The Dynamic Averaging function is enabled. The conversion time for all external diode temperature channels is scaled based on the chosen conversion rate to maximize accuracy and immunity to random temperature measurement variation.
- '1' - The Dynamic Averaging function is disabled. The conversion time for all temperature channels is fixed regardless of the chosen conversion rate.

Bit 5 - DIS_TO - Disables the SMBus time out function for the SMBus client (if enabled).

- '0' (default) - The SMBus timeout and idle functionality are enabled. The SMBus interface will time out if the clock line is held low for longer than 30ms. Likewise, it will reset if both the data and clock lines are held high for longer than 150us.
- '1' - The SMBus timeout and idle functionality are disabled. The SMBus interface will not time out if the clock line is held low. Likewise, it will not reset if both the data and clock lines are held high for longer than 150us. This is used for I²C compliance.

Bit 4 - DIS_AVG - Disables digital averaging of the External Diode 1 channel.

- '0' (default) - The External Diode 1 channel has digital averaging enabled. The temperature data is the average of the previous four measurements.
- '1' - The External Diode 1 channel has digital averaging disabled. The temperature data is the last measured data.

Bits 3-2 - QUEUE[1:0] - Determines the number of consecutive out of limit conditions that are necessary to trigger an interrupt. Each measurement channel has a separate fault queue associated with the high limit and diode fault condition except the internal diode.

The Critical / Thermal Shutdown temperature has a separate fault queue that applies to the selected hardware shutdown channel (see [Section 5.9](#)) when compared against the threshold set by the TRIP_SET pin.

APPLICATION NOTE: If the fault queue for any channel is currently active (i.e. an out of limit condition has been detected and caused the fault queue to increment) then changing the settings will not take effect until the fault queue is zeroed. This occurs by the ALERT pin asserting or the out of limit condition being removed.

Table 6.16 Fault Queue

QUEUE[1:0]		NUMBER OF CONSECUTIVE OUT OF LIMIT CONDITIONS
1	0	
0	0	1 (disabled)
0	1	2
1	0	3
1	1	4 (default)

Bit 1 - 0 - CONV[1:0] - determines the conversion rate of the temperature monitoring. This conversion rate does not affect the fan driver. The supply current from VDD_3V is nominally dependent upon the conversion rate and the average current will increase as the conversion rate increases.

Table 6.17 Conversion Rate

CONV[1:0]		CONVERSION RATE	TEMPERATURE OVER SAMPLING FROM 11 BITS	
1	0		DYN_DIS = '0'	DYN_DIS = '1'
0	0	1 / sec	x8	x1
0	1	2 / sec	x4	x1
1	0	4 / sec (default)	x2	x1
1	1	8 / sec	x1	x1

6.11 Interrupt Status Register

Table 6.18 Interrupt Status Register

ADDR	R/W	REGISTER	B7	B6	B5	B4	B3	B2	B1	B0	DEFAULT
23h	R-C	Interrupt Status Register	RESET	TSD	TCRIT	-	FAN	HIGH	-	FAULT	00h

The Interrupt Status Register reports the operating condition of the EMC2112. If any of the bits are set to a logic '1' (other than RESET and TSD), the ALERT pin will be asserted low if the corresponding channel is enabled. If there are no set status bits, the ALERT pin will be released.

The bits that cause the ALERT pin to be asserted can be masked based on the channel they are associated with unless stated otherwise.

Bit 7 - RESET - This bit is set to '1' if the Reset Generator (see [Section 5.10](#)) has tripped, meaning that the VDD_5V voltage level is less than its normal operating level (and the RESET pin is at a logic '0' state). This bit is cleared when the RESET output changes states to a logic '1'. This bit will not cause the ALERT pin to be asserted.

Datasheet

Bit 6 - TSD - This bit is set to '1' if the internal Thermal Shutdown (TSD) circuit trips indicating that the die temperature has exceeded its threshold. When this bit is set, it will not cause the $\overline{\text{ALERT}}$ pin to be asserted however will coincide with the $\overline{\text{SYS_SHDN}}$ pin being asserted. This bit is cleared when the register is read and the error condition has been removed.

Bit 5 - TCRIT - This bit is set to '1' whenever the any bit in the Tcrit Status Register is set. This bit is automatically cleared when the Tcrit Status Register is cleared.

Bit 3 - FAN - This bit is set to '1' if any bit in the Fan Status Register is set. This bit is automatically cleared when the Fan Status Register is read and the bits are cleared.

Bit 2 - HIGH - This bit is set to '1' if any bit in the High Status Register is set. This bit is automatically cleared when the High Status Register is read and the bits are cleared.

Bit 0 - FAULT - This bit is set to '1' if any bit in the Diode Fault Register is set. This bit is automatically cleared when the Diode Fault Register is read and the bits are cleared.

6.12 Error Status Registers

Table 6.19 Error Status Register

ADDR	R/W	REGISTER	B7	B6	B5	B4	B3	B2	B1	B0	DEFAULT
1Fh	R-C	Tcrit Status	HWS	-	-	-	EXT3_ CRIT	EXT2_ CRIT	EXT1_ CRIT	INT_ CRIT	00h
24h	R-C	High Status	-	-	-	-	EXT3_ HI	EXT2_ HI	EXT1_ HI	INT_ HI	00h
26h	R-C	Diode Fault	-	-	-	-	EXT3_ FLT	EXT2_ FLT	EXT1_ FLT	-	00h

The Error Status Registers report the specific error condition for all measurement channels with limits. If any bit is set in the High, Low, or Diode Fault Status register, the corresponding High, Low, or Fault bit is set in the Interrupt Status Register.

Reading the Interrupt Status Register does not clear the Error Status bit. Reading from any Error Status Register that has bits set will clear the register and the corresponding bit in the Interrupt Status Register if the error condition has been removed. If the error condition is persistent, reading the Error Status Registers will have no affect.

6.12.1 Tcrit Status Register

The Tcrit Status Register stores the event that caused the $\overline{\text{SYS_SHDN}}$ pin to be asserted. Each of the temperature channels must be associated with the $\overline{\text{SYS_SHDN}}$ pin before the corresponding status bit can be set (see [Section 6.8](#)). Once the $\overline{\text{SYS_SHDN}}$ pin is asserted, it will be released when the temperature drops below the threshold level however the individual status bit will not be cleared until read.

Bit 7 - HWS - This bit is set if the hardware set temperature channel meets or exceeds the temperature threshold determined by the TRIP_SET voltage.

6.13 Fan Status Register

Table 6.20 Fan Status Register

ADDR	R/W	REGISTER	B7	B6	B5	B4	B3	B2	B1	B0	DEFAULT
27h	R-C	Fan Status Register	WATCH	-	DRIVE_FAIL	FAN_SHORT	-	-	FAN_SPIN	FAN_STALL	00h

The Fan Status Register contains the status bits associated with each fan driver. This register is cleared when read if the error condition has been removed.

Bit 7 - WATCH - This bit is asserted '1' if the Watchdog timer has expired (see [Section 5.6](#)).

Bit 5 - DRIVE_FAIL - Indicates that the RPM-based Fan Speed Control Algorithm cannot drive the Fan to the desired target setting at maximum drive. This bit can be masked from asserting the $\overline{\text{ALERT}}$ pin.

- '0' - The RPM-based Fan Speed Control Algorithm can drive the Fan to the desired target setting.
- '1' - The RPM-based Fan Speed Control Algorithm cannot drive the Fan to the desired target setting at maximum drive.

Bit 4- FAN_SHORT - This bit is asserted '1' if the High Side Fan Driver detects an over current condition that lasts for longer than 2 seconds.

Bit 1- FAN_SPIN- This bit is asserted '1' if the Spin up Routine for the Fan cannot detect a valid tachometer reading within its maximum time window. This bit can be masked from asserting the $\overline{\text{ALERT}}$ pin.

Bit 0 - FAN_STALL - This bit is asserted '1' if the tachometer measurement on the Fan detects a stalled fan. This bit can be masked from asserting the $\overline{\text{ALERT}}$ pin.

6.14 Interrupt Enable Register

Table 6.21 Interrupt Enable Register

ADDR	R/W	REGISTER	B7	B6	B5	B4	B3	B2	B1	B0	DEFAULT
28	R/W	Interrupt Enable	-	-	-	-	EXT3_INT_EN	EXT2_INT_EN	EXT1_INT_EN	INT_INT_EN	00h

The Interrupt Enable Register controls the masking for each temperature channel. When a channel is masked, it will not cause the $\overline{\text{ALERT}}$ pin to be asserted when an error condition is detected.

Bit 3 - EXT3_INT_EN - Allows the External Diode 3 channel to assert the $\overline{\text{ALERT}}$ pin. This bit can only be set if the APD bit is set.

- '0' (default) - The $\overline{\text{ALERT}}$ pin will not be asserted for any error condition associated with External Diode 3 channel.
- '1' - The $\overline{\text{ALERT}}$ pin will be asserted for an error condition associated with External Diode 3 channel.

Bit 2 - EXT2_INT_EN - Allows the External Diode 2 channel to assert the $\overline{\text{ALERT}}$ pin.

- '0' (default) - The $\overline{\text{ALERT}}$ pin will not be asserted for any error condition associated with External Diode 2 channel.
- '1' - The $\overline{\text{ALERT}}$ pin will be asserted for an error condition associated with External Diode 2 channel.

Datasheet

Bit 1 - EXT1_INT_EN - Allows the External Diode 1 channel to assert the $\overline{\text{ALERT}}$ pin.

- '0' (default) - The $\overline{\text{ALERT}}$ pin will not be asserted for any error condition associated with External Diode 1 channel.
- '1' - The $\overline{\text{ALERT}}$ pin will be asserted for an error condition associated with External Diode 1 channel.

Bit 0 - INT_INT_EN - Allows the Internal Diode channel to assert the $\overline{\text{ALERT}}$ pin.

- '0' (default) - The $\overline{\text{ALERT}}$ pin will not be asserted for any error condition associated with the Internal Diode.
- '1' - The $\overline{\text{ALERT}}$ pin will be asserted for an error condition associated with the Internal Diode.

6.15 Fan Interrupt Enable Register

Table 6.22 Fan Interrupt Enable Register

ADDR	R/W	REGISTER	B7	B6	B5	B4	B3	B2	B1	B0	DEFAULT
29h	R/W	Fan Interrupt Enable	-	-	-	-	-	-	SPIN_INT_EN	STALL_INT_EN	00h

The Fan Interrupt Enable controls the masking for each Fan channel. When a channel is enabled, it will cause the $\overline{\text{ALERT}}$ pin to be asserted when an error condition is detected.

Bit 1 - SPIN_INT_EN - Allows the FAN_SPIN bit to assert the $\overline{\text{ALERT}}$ pin.

- '0' (default) - the FAN_SPIN bit will not assert the $\overline{\text{ALERT}}$ pin though it will still update the Status Register normally.
- '1' - the FAN_SPIN bit will assert the $\overline{\text{ALERT}}$ pin.

Bit 0 - STALL_INT_EN - Allows the FAN_STALL bit or DRIVE_FAIL bit to assert the $\overline{\text{ALERT}}$ pin.

- '0' (default) - the FAN_STALL bit or DRIVE_FAIL bit will not assert the $\overline{\text{ALERT}}$ pin though will still update the Status Register normally.
- '1' - the FAN_STALL or DRIVE_FAIL bit will assert the $\overline{\text{ALERT}}$ pin if set.

6.16 Limit Registers

Table 6.23 Limit Registers

ADDR	R/W	REGISTER	B7	B6	B5	B4	B3	B2	B1	B0	DEFAULT
30h	R/W	External Diode 1 High Limit	Sign	64	32	16	8	4	2	1	55h (+85°C)
31h	R/W	External Diode 2 High Limit	Sign	64	32	16	8	4	2	1	55h (+85°C)
32h	R/W	External Diode 3 High Limit	Sign	64	32	16	8	4	2	1	55h (+85°C)
34h	R/W	Internal Diode High Limit	Sign	64	32	16	8	4	2	1	55h (+85°C)

The EMC2112 contains high limits for all temperature channels and voltage channels. If any measurement meets or exceeds the high limit then the appropriate status bit is set and the ALERT pin is asserted (if enabled).

All Limit Registers are Software Locked.

6.17 Fan Setting Register

Table 6.24 Fan Setting Register

ADDR	R/W	REGISTER	B7	B6	B5	B4	B3	B2	B1	B0	DEFAULT
40h	R/W	Fan Setting	128	64	32	16	8	4	2	1	00h

The Fan Setting Register always displays the current setting of the Fan Driver. Reading from the register will report the current fan speed setting of the fan driver regardless of the operating mode. Therefore it is possible that reading from this register will not report data that was previously written into this register.

While the RPM-based Fan Speed Control Algorithm is active, then the register is read only. Writing to the register will have no affect and the data will not be stored.

If the RPM-based Fan Control Algorithm is disabled, then the register will be set with the previous value that was used. The register is read / write and writing to this register will affect the fan speed.

The contents of the register represent the weighting of each bit in determining the final output voltage. The output drive for the High Side Fan Driver output is given by [Equation \[2\]](#).

$$Drive = \left(\frac{VALUE}{255} \right) \times VDD_5V \quad [2]$$

6.18 Fan Configuration 1 Register

Table 6.25 Fan Configuration 1 Register

ADDR	R/W	REGISTER	B7	B6	B5	B4	B3	B2	B1	B0	DEFAULT
42h	R/W	Fan Configuration 1	EN_ALGO	RANGE[1:0]		EDGES[1:0]		UPDATE[2:0]			2Bh

The Fan Configuration 1 Register controls the general operation of the RPM-based Fan Speed Control Algorithm used for the Fan 1 driver.

Bit 7 - EN_ALGO - enables the RPM-based Fan Speed Control Algorithm.

- '0' - (default) the control circuitry is disabled and the fan driver output is determined by the Fan Driver Setting Register.
- '1' - the control circuitry is enabled and the Fan Driver output will be automatically updated to maintain the programmed fan speed as indicated by the TACH Target Register.

Bits 6 - 5 - RANGE[1:0] - Adjusts the range of reported and programmed tachometer reading values. The RANGE bits determine the weighting of all TACH values (including the Valid TACH Count, TACH Target, and TACH reading) as shown in [Table 6.26](#).

Table 6.26 Range Decode

RANGE[1:0]		REPORTED MINIMUM RPM	TACH COUNT MULTIPLIER
1	0		
0	0	500	1
0	1	1000 (default)	2
1	0	2000	4
1	1	4000	8

Bits 4-3 - EDGES[1:0] - determines the minimum number of edges that must be detected on the TACH signal to determine a single rotation. A typical fan measured 5 edges (for a 2-pole fan). For more accurate tachometer measurement, the minimum number of edges measured may be increased.

Increasing the number of edges measured with respect to the number of poles of the fan will cause the TACH Reading registers to indicate a fan speed that is higher or lower than the actual speed. In order for the FSC Algorithm to operate correctly, the TACH Target must be updated by the user to accommodate this shift. The Effective Tach Multiplier shown in Table 6.27 is used as a direct multiplier term that is applied to the Actual RPM to achieve the Reported RPM. It should only be applied if the number of edges measured does not match the number of edges expected based on the number of poles of the fan (which is fixed for any given fan).

Contact SMSC for recommended settings when using fans with more or less than 2 poles.

Table 6.27 Minimum Edges for Fan Rotation

EDGES[1:0]		MINIMUM TACH EDGES	NUMBER OF FAN POLES	EFFECTIVE TACH MULTIPLIER (BASED ON 2 POLE FANS)
1	0			
0	0	3	1 pole	0.5
0	1	5	2 poles (default)	1
1	0	7	3 poles	1.5
1	1	9	4 poles	2

Bit 2-0 - UPDATE - determines the base time between fan driver updates. The Update Time, along with the Fan Step Register, is used to control the ramp rate of the drive response to provide a cleaner transition of the actual fan operation as the desired fan speed changes. The Update Time is set as shown in Table 6.28.

Table 6.28 Update Time

UPDATE[2:0]			UPDATE TIME
2	1	0	
0	0	0	100ms
0	0	1	200ms
0	1	0	300ms

Table 6.28 Update Time (continued)

UPDATE[2:0]			UPDATE TIME
2	1	0	
0	1	1	400ms (default)
1	0	0	500ms
1	0	1	800ms
1	1	0	1200ms
1	1	1	1600ms

6.19 Fan Configuration 2 Register

Table 6.29 Fan Configuration 1 Register

ADDR	R/W	REGISTER	B7	B6	B5	B4	B3	B2	B1	B0	DEFAULT
43h	R/W	Fan Configuration 2	TEMP_RR	EN_RRC	GLITCH_EN	DER_OPT [1:0]		ERR_RNG[1:0]		-	28h

The Fan Configuration 2 Register controls the tachometer measurement and advanced features of the RPM-based Fan Speed Control Algorithm.

Bit 7 - TEMP_RR - Overrides max step controls for the FSC algorithm when any temperature exceeds its respective high limit.

- '0' (default) - All ramp rate control circuitry works at all times for the FSC algorithm or as determined by the EN_RRC bit for manual mode.
- '1' - If any measured temperature or the PWM Input Duty cycle meets or exceeds its respective high limit, then the Fan Max Step register settings are not used and the FSC algorithm acts as if the Max Step settings were at 3Fh. The device will continue to operate in this way until all temperatures (and the PWM input duty cycle) have dropped below the respective high limit.

Bit 6 - EN_RRC - Enables ramp rate control when the fan driver is operated in the Direct Setting Mode.

- '0' (default) - Ramp rate control is disabled. When the fan driver is operating in Direct Setting mode, the fan setting will instantly transition to the next programmed setting.
- '1' - Ramp rate control is enabled. When the fan driver is operating in Direct Setting mode, the fan drive setting will follow the ramp rate controls as determined by the Fan Step and Update Time settings. The maximum fan drive setting step is capped at the Fan Step setting and is updated based on the Update Time as given by [Table 6.28](#).

Bit 5 - GLITCH_EN - Disables the low pass glitch filter that removes high frequency noise injected on the TACH pin.

- '0' - The glitch filter is disabled.
- '1' (default) - The glitch filter is enabled.

Bits 4 - 3 - DER_OPT[1:0] - Control some of the advanced options that affect the derivative portion of the RPM-based Fan Speed Control Algorithm as shown in [Table 6.30](#).

Table 6.30 Derivative Options

DER_OPT[1:0]		OPERATION
1	0	
0	0	No derivative options used
0	1	Basic derivative. The derivative of the error from the current drive setting and the target is added to the iterative Fan Drive Register setting (in addition to proportional and integral terms) (default)
1	0	Step derivative. The derivative of the error from the current drive setting and the target is added to the iterative Fan Drive Register setting and is not capped by the Fan Step Register. This allows faster response times than the basic derivative.
1	1	Both the basic derivative and the step derivative are used effectively causing the derivative term to have double the effect of the derivative term.

Bit 2 - 1 - ERR_RNG[1:0] - Control some of the advanced options that affect the error window. When the measured fan speed is within the programmed error window around the target speed, then the fan drive setting is not updated. The algorithm will continue to monitor the fan speed and calculate necessary drive setting changes based on the error, however these changes are ignored.

Table 6.31 Error Range Options

ERR_RNG[1:0]		OPERATION
1	0	
0	0	0 RPM (default)
0	1	50 RPM
1	0	100 RPM
1	1	200 RPM

6.20 Gain Register

Table 6.32 Gain Register

ADDR	R/W	REGISTER	B7	B6	B5	B4	B3	B2	B1	B0	DEFAULT
45h	R/W	Gain Register	-	-	GAIND[1:0]		GAINI[1:0]		GAINP[1:0]		2Ah

The Gain Register stores the gain terms used by the proportional and integral portions of each of the RPM-based Fan Speed Control Algorithms. These gain terms are used as the KD, KI, and KP gain terms in a classic PID control solution.

Table 6.33 Gain Decode

GAIND OR GAINP OR GAINI [1:0]		RESPECTIVE GAIN FACTOR
1	0	
0	0	1x
0	1	2x
1	0	4x (default)
1	1	8x

6.21 Fan Spin Up Configuration Register

Table 6.34 Fan Spin Up Configuration Register

ADDR	R/W	REGISTER	B7	B6	B5	B4	B3	B2	B1	B0	DEFAULT
46h	R/W	Fan Spin Up Configuration	DRIVE_FAIL_CNT [1:0]		NOKICK	SPIN_LVL[2:0]			SPINUP_TIME[1:0]		19h

The Fan Spin Up Configuration Register controls the settings of Spin Up Routine. The Fan Spin Up Configuration Register is software locked.

Bit 7 - 6 - DRIVE_FAIL_CNT[1:0] - Determines how many update cycles are used for the Drive Fail detection function as shown in [Table 6.35](#). This circuitry determines whether the fan can be driven to the desired tach target.

Table 6.35 DRIVE_FAIL_CNT[1:0] Bit Decode

DRIVE_FAIL_CNT[1:0]		NUMBER OF UPDATE PERIODS
1	0	
0	0	Disabled - the Drive Fail detection circuitry is disabled (default)
0	1	16 - the Drive Fail detection circuitry will count for 16 update periods
1	0	32 - the Drive Fail detection circuitry will count for 32 update periods
1	1	64 - the Drive Fail detection circuitry will count for 64 update periods

Bit 5 - NOKICK - Determines if the Spin Up Routine will drive the fan to 100% duty cycle for 1/4 of the programmed spin up time before driving it at the programmed level.

- '0' (default) - The Spin Up Routine will drive the fan driver to 100% for 1/4 of the programmed spin up time before reverting to the programmed spin level.
- '1' - The Spin Up Routine will not drive the fan driver to 100%. It will set the drive at the programmed spin level for the entire duration of the programmed spin up time.

Datasheet

Bits 4 - 2 - SPIN_LVL[2:0] - Determines the final drive level that is used by the Spin Up Routine as shown in [Table 6.36](#).

Table 6.36 Spin Level

SPIN_LVL[2:0]			SPIN UP DRIVE LEVEL
2	1	0	
0	0	0	30%
0	0	1	35%
0	1	0	40%
0	1	1	45%
1	0	0	50%
1	0	1	55%
1	1	0	60% (default)
1	1	1	65%

Bit 1 -0 - SPINUP_TIME[1:0] - determines the maximum Spin Time that the Spin Up Routine will run for (see [Section 5.2](#)). If a valid tachometer measurement is not detected before the Spin Time has elapsed, then an interrupt will be generated. When the RPM-based Fan Speed Control Algorithm is active, the fan driver will attempt to re-start the fan immediately after the end of the last spin up attempt.

The Spin Time is set as shown in [Table 6.37](#).

Table 6.37 Spin Time

SPINUP_TIME[1:0]		TOTAL SPIN UP TIME
1	0	
0	0	250 ms
0	1	500 ms (default)
1	0	1 sec
1	1	2 sec

6.22 Fan Max Step Register

Table 6.38 Fan Max Step Register

ADDR	R/W	REGISTER	B7	B6	B5	B4	B3	B2	B1	B0	DEFAULT
47h	R/W	Fan Max Step	-	-	32	16	8	4	2	1	10h

The Fan Max Step Register, along with the Update Time, controls the ramp rate of the fan driver response calculated by the RPM-based Fan Speed Control Algorithm. The value of the registers represents the maximum step size each fan driver will take between update times (see [Section 6.18](#)).

When the FSC algorithm is enabled, Ramp Rate control is automatically used. When the FSC is not active, then Ramp Rate control can be enabled by asserting the EN_RRC bit (see [Section 6.19](#))

APPLICATION NOTE: The UPDATE bits and Fan Step Register settings operate independently of the RPM-based Fan Speed Control Algorithm and will always limit the fan drive setting. That is, if the programmed fan drive setting (either in determined by the RPM-based Fan Speed Control Algorithm or by manual settings) exceeds the current fan drive setting by greater than the Fan Step Register setting, the EMC2112 will limit the fan drive change to the value of the Fan Step Register. It will use the Update Time to determine how often to update the drive settings.

APPLICATION NOTE: If the Fan Speed Control Algorithm is used, the default settings in the Fan Configuration 2 Register will cause the maximum fan step settings to be ignored.

The Fan Step Registers are software locked.

6.23 Fan Minimum Drive Register

Table 6.39 Minimum Fan Drive Register

ADDR	R/W	REGISTER	B7	B6	B5	B4	B3	B2	B1	B0	DEFAULT
48h	R/W	Fan Minimum Drive	128	64	32	16	8	4	2	1	66h (40%)

The Fan Minimum Drive Register stores the minimum drive setting for each RPM-based Fan Speed Control Algorithm. The RPM-based Fan Speed Control Algorithm will not drive the fan at a level lower than the minimum drive unless the target Fan Speed is set at FFh (see [Section 6.26](#))

During normal operation, if the fan stops for any reason (including low drive), the RPM-based Fan Speed Control Algorithm will attempt to restart the fan. Setting the Fan Minimum Drive Registers to a setting that will maintain fan operation is a useful way to avoid potential fan oscillations as the control circuitry attempts to drive it at a level that cannot support fan operation.

The Fan Minimum Drive Register is software locked.

6.24 Valid TACH Count Register

Table 6.40 Valid TACH Count Register

ADDR	R/W	REGISTER	B7	B6	B5	B4	B3	B2	B1	B0	DEFAULT
49h	R/W	Valid TACH Count	4096	2048	1024	512	256	128	64	32	F5h

The Valid TACH Count Register stores the maximum TACH Reading Register value to indicate that the each fan is spinning properly. The value is referenced at the end of the Spin Up Routine to determine if the fan has started operating and decide if the device needs to retry. See [Equation \[3\]](#) for translating the count to an RPM. This register is only used when the FSC is active.

If the TACH Reading Register value exceeds the Valid TACH Count Register (indicating that the Fan RPM is below the threshold set by this count), then a stalled fan is detected. In this condition, the algorithm will automatically begin its Spin Up Routine.

If a TACH Target setting is set above the Valid TACH Count setting, then that setting will be ignored and the algorithm will use the current fan drive setting.

The Valid TACH Count Register is software locked.

6.25 Fan Drive Fail Band Registers

Table 6.41 Fan Drive Fail Band Registers

ADDR	R/W	REGISTER	B7	B6	B5	B4	B3	B2	B1	B0	DEFAULT
4Ah	R/W	Fan Drive Fail Band Low Byte	16	8	4	2	1	-	-	-	00h
4Bh	R/W	Fan Drive Fail Band High Byte	4096	2048	1024	512	256	128	64	32	00h

The Fan Drive Fail Band Registers store the number of tach counts used by the Fan Drive Fail detection circuitry. This circuitry is activated when the fan drive setting high byte is at FFh. When it is enabled, the actual measured fan speed is compared against the target fan speed. These registers are only used when the FSC is active.

This circuitry is used to indicate that the target fan speed at full drive is higher than the fan is actually capable of reaching. If the measured fan speed does not exceed the target fan speed minus the Fan Drive Fail Band Register settings for a period of time longer than set by the DRIVE_FAIL_CNTx[1:0] bits then the DRIVE_FAIL status bit will be set and an interrupt generated.

6.26 TACH Target Registers

Table 6.42 TACH Target Registers

ADDR	R/W	REGISTER	B7	B6	B5	B4	B3	B2	B1	B0	DEFAULT
4Ch	R/W	TACH Target Low Byte	16	8	4	2	1	-	-	-	F8h
4Dh	R/W	TACH Target High Byte	4096	2048	1024	512	256	128	64	32	FFh

The TACH Target Registers hold the target tachometer value that is maintained each of the RPM-based Fan Speed Control Algorithms.

If one of the algorithms is enabled then setting the TACH Target Register to FFh will disable the fan driver (set the fan drive setting to 0%). Setting the TACH Target to any other value (from a setting of FFh) will cause the algorithm to invoke the Spin Up Routine after which it will function normally.

The Tach Target is not applied until the high byte is written. Once the high byte is written, the current value of both high and low bytes will be used as the next Tach target. 3

6.27 TACH Reading Registers

Table 6.43 TACH Reading Registers

ADDR	R/W	REGISTER	B7	B6	B5	B4	B3	B2	B1	B0	DEFAULT
4Eh	R	Fan TACH	4096	2048	1024	512	256	128	64	32	FFh
4Fh	R	Fan TACH Low Byte	16	8	4	2	1	-	-	-	F8h

The TACH Reading Registers' contents describe the current tachometer reading for each of the fan. By default, the data represents the fan speed as the number of 32kHz clock periods that occur for a single revolution of the fan.

Equation [3] shows the detailed conversion from TACH measurement (COUNT) to RPM while Equation [4] shows the simplified translation of TACH Reading Register count to RPM assuming a 2-pole fan, measuring 5 edges, with a frequency of 32.768kHz. These equations are solved and tabulated for ease of use in AN17.4 RPM to TACH Counts Conversion.

Whenever the high byte register is read, the corresponding low byte data will be loaded to internal shadow registers so that when the low byte is read, the data will always coincide with the previously read high byte.

where:

poles = number of poles of the fan
(typically 2)

f_{TACH} = the tachometer
measurement frequency (typically
32.768kHz) **[3]**

n = number of edges measured
(typically 5 for a 2 pole fan)

m = the multiplier defined by the
RANGE bits

COUNT = TACH Reading Register
value (in decimal) **[4]**

$$RPM = \frac{1}{(poles)} \times \frac{(n-1)}{COUNT \times \frac{1}{m}} \times f_{TACH} \times 60$$

$$RPM = \frac{3,932,160 \times m}{COUNT}$$

Bit 2 - IDCF_5 - Sets the bit state of IDCFx bit 5.

Bit 1 - IDCF_4 - Sets the bit state of IDCFx bit 4.

Bit 0 - IDCF_3 - Sets the bit state of IDCFx bit 3.

Prior to enabling the RUN_ALI bit, the TATRIM and TYPE[1:0] bits must be set to the desired settings.

6.28 Software Lock Register

Table 6.44 Software Lock Register

ADDR	R/W	REGISTER	B7	B6	B5	B4	B3	B2	B1	B0	DEFAULT
EFh	R/W	Software Lock	-	-	-	-	-	-	-	LOCK	00h

The Software Lock Register controls the software locking of critical registers. This register is software locked.

Bit 0 - LOCK - this bit acts on all registers that are designated SWL. When this bit is set, the locked registers become read only and cannot be updated.

- '0' (default) - all SWL registers can be updated normally.
- '1' - all SWL registers cannot be updated and a hard-reset is required to unlock them.

6.29 Product Features Register

Table 6.45 Product Features Register

ADDRESS	R/W	REGISTER	B7	B6	B5	B4	B3	B2	B1	B0	DEFAULT
FCh	R	Product Features	-	-	-	-	ADR[1:0]		SHDN_CH [1:0]		00h

The Product Features register shows those functions that are enabled by external pin states.

Bits 3-2 - ADR[2:0] - Indicates the selected SMBus address as determined by the ADDR_SEL pin.

Table 6.46 ADDR_SEL Pin Configuration

ADR[1:0]		SLAVE ADDRESS
1	0	
0	0	0101_111xb
0	1	0111_101xb
1	0	0101_110xb

Bits 1-0 - SHDN_CH[1:0] - Indicates the selected temperature channel associated with the Critical / Thermal Shutdown logic (see [Section 5.9](#)).

Table 6.47 SHDN_CH Pin Configuration

SHDN_CH [1:0]		HARDWARE SHUTDOWN CHANNEL
1	0	
0	0	External Diode 1 measuring CPU / GPU diode
0	1	External Diode 1 measuring AMD or discrete diode
1	0	External Diode 2 measuring discrete diode

6.30 Product ID Register

Table 6.48 Product ID Register

ADDRESS	R/W	REGISTER	B7	B6	B5	B4	B3	B2	B1	B0	DEFAULT
FDh	R	Product ID	0	0	0	1	0	1	0	1	15h

The Product ID Register contains a unique 8 bit word that identifies the product.

6.31 Manufacturer ID Register

Table 6.49 Manufacturer ID Register

ADDRESS	R/W	REGISTER	B7	B6	B5	B4	B3	B2	B1	B0	DEFAULT
FEh	R	Manufacturer ID	0	1	0	1	1	1	0	1	5Dh

The Manufacturer ID Register contains a unique 8 bit word that identifies SMSC.

6.32 Revision Register

Table 6.50 Revision Register

ADDRESS	R/W	REGISTER	B7	B6	B5	B4	B3	B2	B1	B0	DEFAULT
FFh	R	Revision	0	0	0	0	0	0	0	1	01h

The Revision Register contains a 8 bit word that identifies the die revision.

Chapter 7 Typical Operating Curves

The following Typical Operating Curves are included.

- Supply Current vs. Temperature
- Supply Current vs. Supply Voltage
- Temperature Error vs. Series Resistance
- Temperature Error vs. C_{FILTER}
- Temperature Error vs. Ambient Temperature
- Temperature Error vs. Supply Voltage
- Tachometer Measurement Accuracy vs. Temperature
- Tachometer Measurement Accuracy vs. Supply Voltage
- High Side Drive Voltage vs. Temperature
- Reset Generator Threshold vs. Temperature
- Reset Generator Threshold vs. Supply Voltage

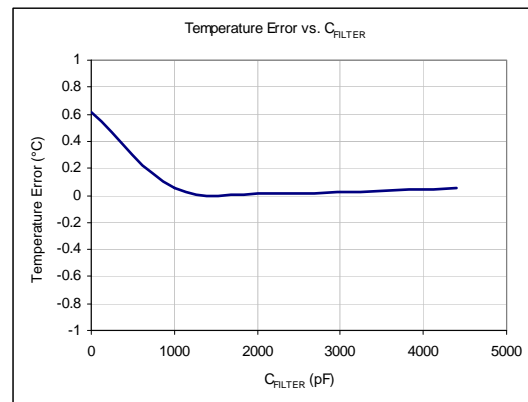
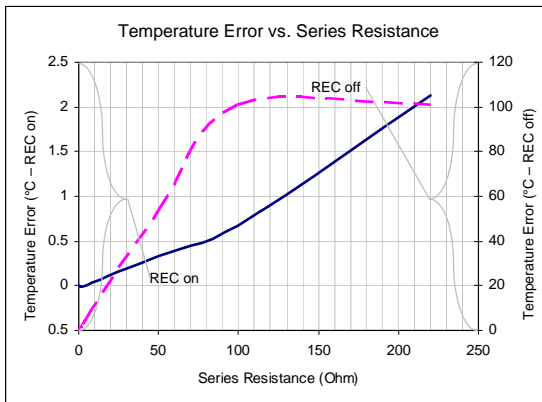
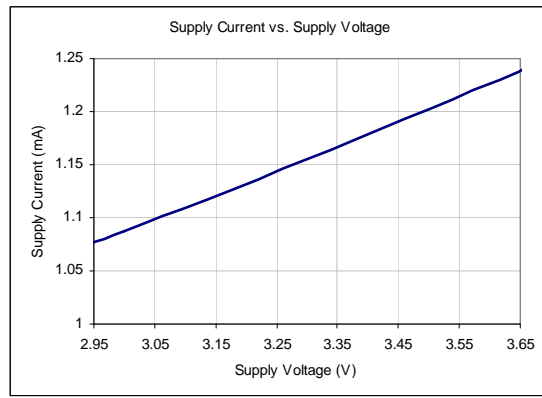
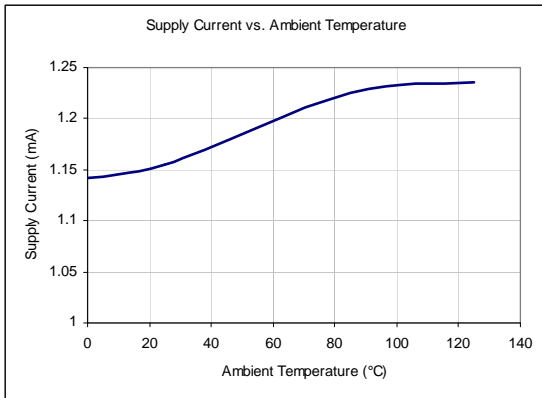

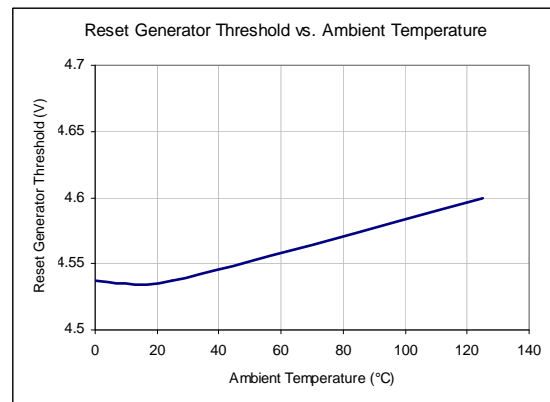
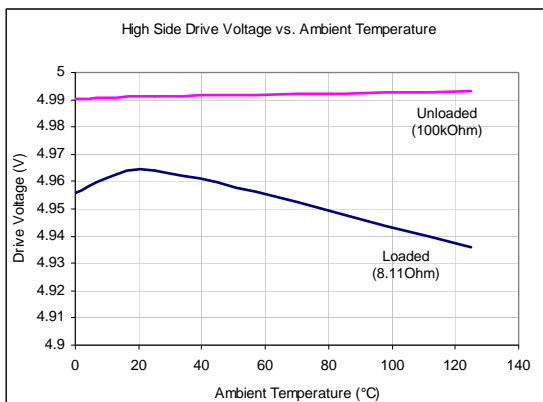
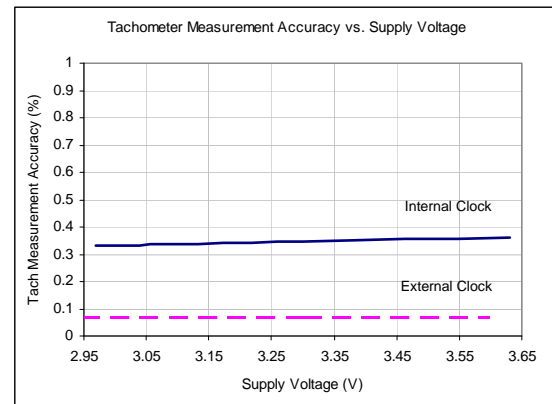
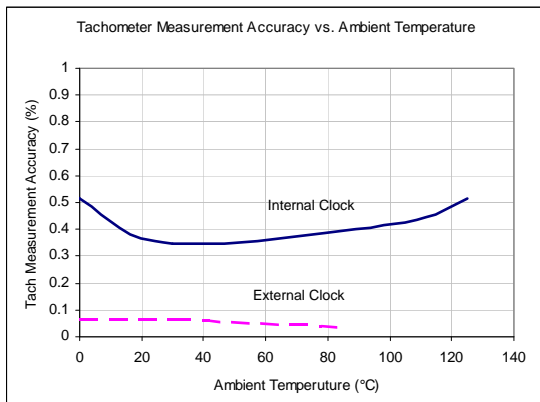
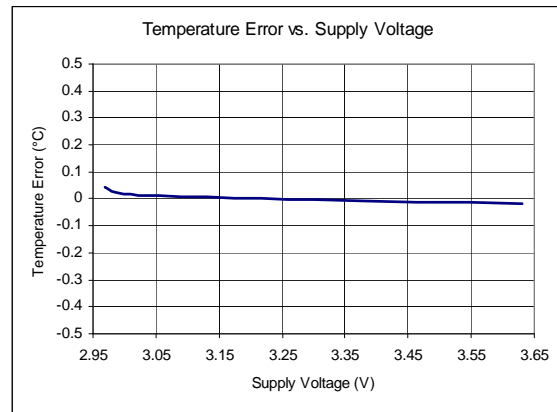
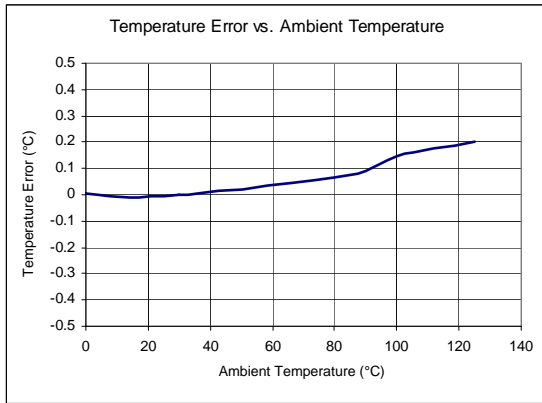

Datasheet

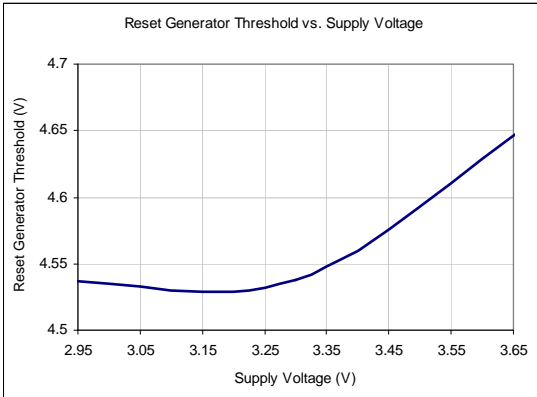

Chapter 8 Package Outline

8.1 EMC2112 Package Drawings - 20-Pin QFN 4mm x 4mm

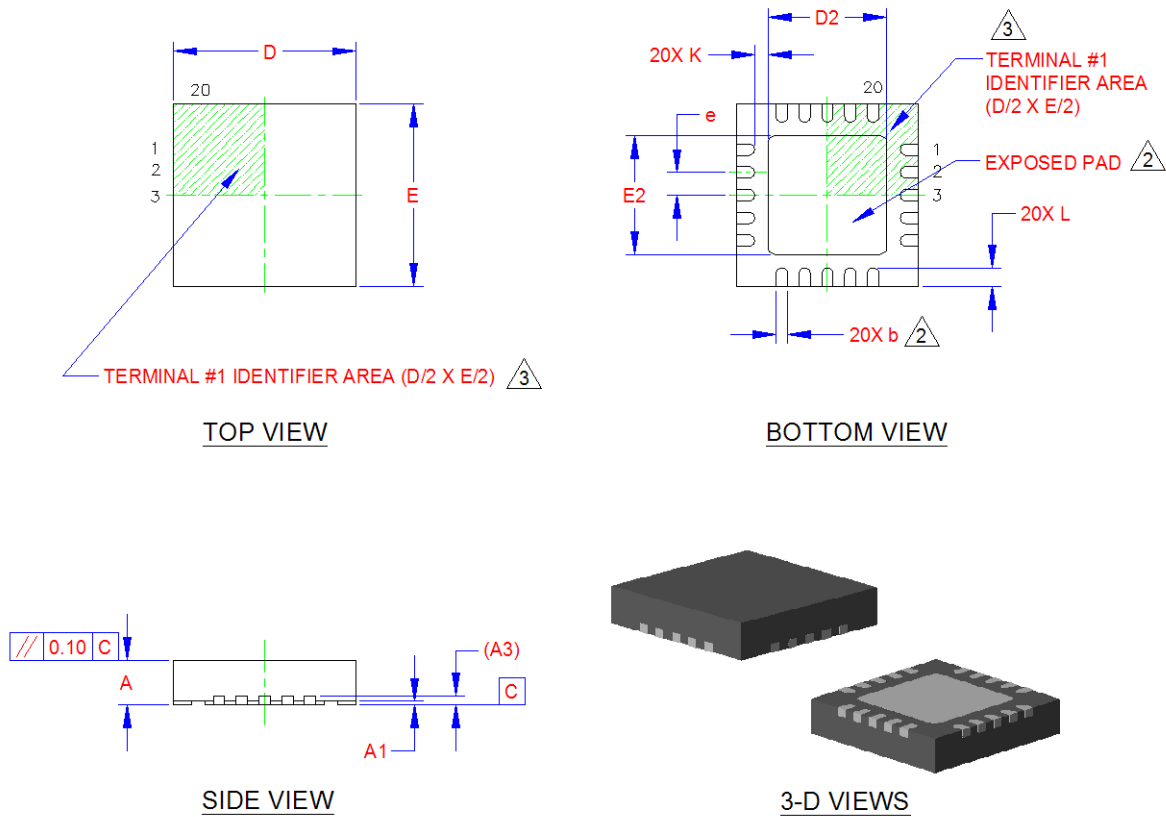

Figure 8.1 EMC2112 Package Drawing - 20-Pin QFN 4mm x 4mm

COMMON DIMENSIONS					
SYMBOL	MIN	NOM	MAX	NOTE	REMARK
A	0.80	0.85	0.90	-	OVERALL PACKAGE HEIGHT
A1	0	0.02	0.05	-	STANDOFF
A3	0.20 REF			-	LEAD-FRAME THICKNESS
D/E	3.90	4.00	4.10	-	X/Y BODY SIZE
D2/E2	2.50	2.60	2.70	2	X/Y EXPOSED PAD SIZE
L	0.35	0.40	0.45	-	TERMINAL LENGTH
b	0.18	0.25	0.30	2	TERMINAL WIDTH
K	0.20	-	-	-	TERMINAL TO PAD DISTANCE
e	0.50 BSC			-	TERMINAL PITCH

NOTES:

1. ALL DIMENSIONS ARE IN MILLIMETERS.
2. POSITION TOLERANCE OF EACH TERMINAL AND EXPOSED PAD IS $\pm 0.05\text{mm}$ AT MAXIMUM MATERIAL CONDITION. DIMENSIONS "b" APPLIES TO PLATED TERMINALS AND IT IS MEASURED BETWEEN 0.15 AND 0.30 mm FROM THE TERMINAL TIP.
3. DETAILS OF TERMINAL #1 IDENTIFIER ARE OPTIONAL BUT MUST BE LOCATED WITHIN THE AREA INDICATED.

Figure 8.2 EMC2112 Package Dimensions and Notes - 20-Pin QFN 4mm x 4mm

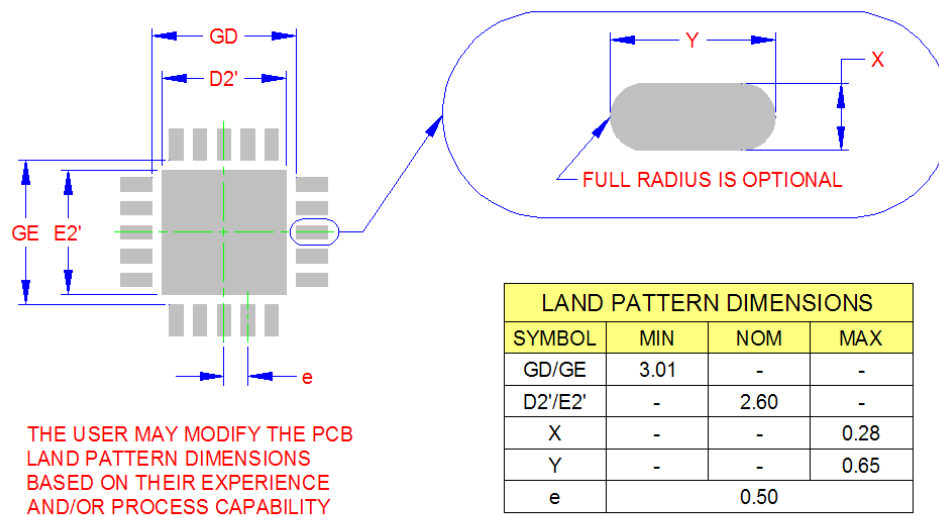

RECOMMENDED PCB LAND PATTERN

Figure 8.3 EMC2112 PCB Footprint - 20-Pin QFN 4mm x 4mm

8.2 Package Marking Information

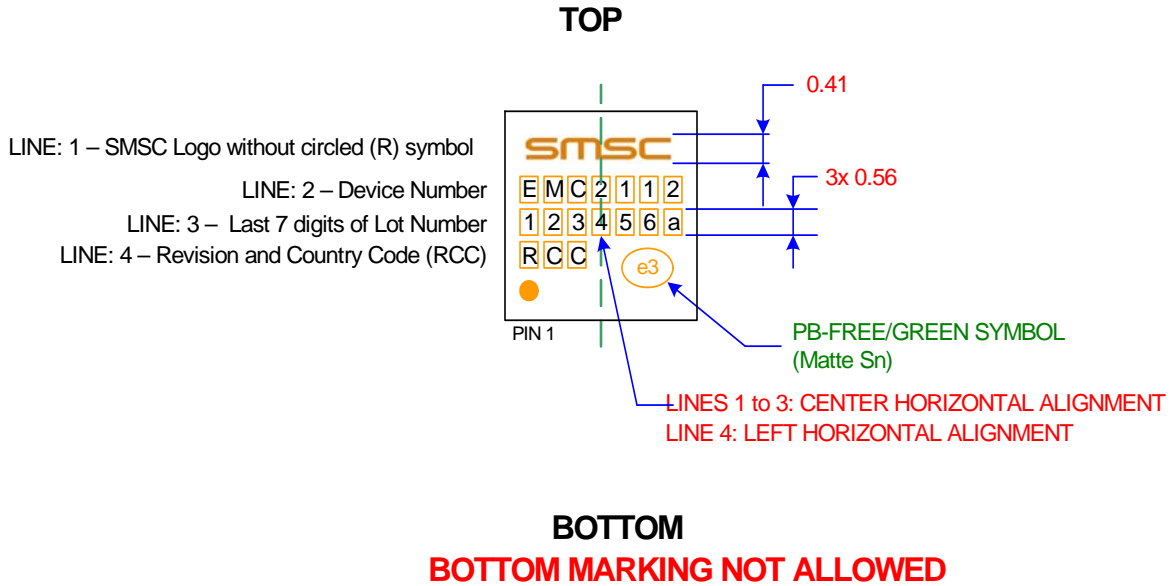

Figure 8.4 EMC2112 Package Markings

Chapter 9 Datasheet Revision History

Table 9.1 Customer Revision History

REVISION LEVEL & DATE	SECTION/FIGURE/ENTRY	CORRECTION
Rev. 0.88 (11-20-09)	Figure 5.4, "EMC2112 Critical/Thermal Shutdown Block Diagram"	Updated figure to show SYS_SHDN# is open drain.
	Section 6.32, "Revision Register"	Updated value of Revision Register (FFh) from 00h to 01h to reflect the new die revision.
	Chapter 7, Typical Operating Curves	Added.
Rev. 0.87 (05-21-09)	Table 3.1, "Absolute Maximum Ratings"	Updated "Junction to Ambient": from "16 pin QFN" to "20 pin QFN"
	Note 3.2 (following Table 3.1, "Absolute Maximum Ratings")	Note modified: from "ground plane with 3.1mm x 3.1mm" to "ground plane with 2.6mm x 2.6mm"
	Section 6.27, "TACH Reading Registers"	Added reference to AN17.4
	Table 3.2, "Electrical Specifications"	Updated electrical specifications for supply current, tach accuracy, and VOH / VOL conditions on digital pins
Rev. 0.85 (01-08-09)	Initial datasheet release	