

Single N-Channel Logic Level Enhancement Mode Field Effect Transistor

Product Summary:

|                     |                |
|---------------------|----------------|
| $BV_{DSS}$          | 150V           |
| $R_{DS(on)}$ (MAX.) | 11.5m $\Omega$ |
| $I_D$               | 45A            |

Pin Description:

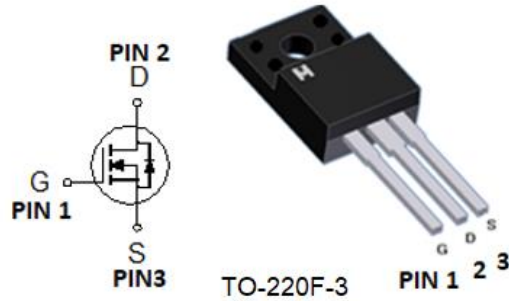

Single N Channel MOSFET

UIS, Rg 100% Tested

Pb-Free Lead Plating & Halogen Free



ABSOLUTE MAXIMUM RATINGS ( $T_A = 25\text{ }^\circ\text{C}$  Unless Otherwise Noted)

| PARAMETERS/TEST CONDITIONS                     |  | SYMBOL           | LIMITS     | UNIT             |
|--|--|------------------|------------|------------------|
| Gate-Source Voltage                            |  | $V_{GS}$         | $\pm 20$   | V                |
| Continuous Drain Current                       | $T_C = 25\text{ }^\circ\text{C}$                     | $I_D$            | 45         | A                |
|  | $T_C = 100\text{ }^\circ\text{C}$                    |                  | 28         |                  |
| Pulsed Drain Current <sup>1</sup>              |  | $I_{DM}$         | 180        |                  |
| Avalanche Current                              |  | $I_{AS}$         | 30         |                  |
| Avalanche Energy                               | $L = 0.1\text{mH}, I_D = 30\text{A}, R_G = 25\Omega$ | $E_{AS}$         | 45         | mJ               |
| Repetitive Avalanche Energy <sup>2</sup>       | $L = 0.05\text{mH}$                                  | $E_{AR}$         | 22.5       |                  |
| Power Dissipation                              | $T_C = 25\text{ }^\circ\text{C}$                     | $P_D$            | 41         | W                |
|  | $T_C = 100\text{ }^\circ\text{C}$                    |                  | 16         |                  |
| Operating Junction & Storage Temperature Range |  | $T_{j}, T_{stg}$ | -55 to 150 | $^\circ\text{C}$ |

THERMAL RESISTANCE RATINGS

| THERMAL RESISTANCE  | SYMBOL          | TYPICAL | MAXIMUM | UNIT                        |
|---------------------|-----------------|---------|---------|-----------------------------|
| Junction-to-Case    | $R_{\theta JC}$ |         | 3.0     | $^\circ\text{C} / \text{W}$ |
| Junction-to-Ambient | $R_{\theta JA}$ |         | 62.5    |                             |

<sup>1</sup>Pulse width limited by maximum junction temperature.

<sup>2</sup>Duty cycle  $\leq 1\%$

<sup>3</sup>Pulsed drain current rating is package limited.



ELECTRICAL CHARACTERISTICS (T<sub>J</sub> = 25 °C, Unless Otherwise Noted)

| PARAMETER   | SYMBOL               | TEST CONDITIONS   | LIMITS |      |      | UNIT |
|---|----------------------|---|--------|------|------|------|
|   |                      |   | MIN    | TYP  | MAX  |      |
| <b>STATIC</b>   |                      |   |        |      |      |      |
| Drain-Source Breakdown Voltage  | V <sub>(BR)DSS</sub> | V <sub>GS</sub> = 0V, I <sub>D</sub> = 250μA  | 150    |      |      | V    |
| Gate Threshold Voltage  | V <sub>GS(th)</sub>  | V <sub>DS</sub> = V <sub>GS</sub> , I <sub>D</sub> = 250μA                                  | 2.0    | 3.0  | 4.0  |      |
| Gate-Body Leakage   | I <sub>GSS</sub>     | V <sub>DS</sub> = 0V, V <sub>GS</sub> = ±20V  |        |      | ±100 | nA   |
| Zero Gate Voltage Drain Current   | I <sub>DSS</sub>     | V <sub>DS</sub> = 120V, V <sub>GS</sub> = 0V  |        |      | 1    | μA   |
|   |                      | V <sub>DS</sub> = 100V, V <sub>GS</sub> = 0V, T <sub>J</sub> = 125 °C                       |        |      | 25   |      |
| On-State Drain Current <sup>1</sup>   | I <sub>D(ON)</sub>   | V <sub>DS</sub> = 10V, V <sub>GS</sub> = 10V  | 45     |      |      | A    |
| Drain-Source On-State Resistance <sup>1</sup>                                 | R <sub>DS(ON)</sub>  | V <sub>GS</sub> = 10V, I <sub>D</sub> = 20A   |        | 9.3  | 11.5 | mΩ   |
| Forward Transconductance <sup>1</sup>   | g <sub>fs</sub>      | V <sub>DS</sub> = 5V, I <sub>D</sub> = 20A  |        | 90   |      | S    |
| <b>DYNAMIC</b>  |                      |   |        |      |      |      |
| Input Capacitance   | C <sub>iss</sub>     | V <sub>GS</sub> = 0V, V <sub>DS</sub> = 75V, f = 1MHz                                       |        | 4805 |      | pF   |
| Output Capacitance  | C <sub>oss</sub>     |   |        | 360  |      |      |
| Reverse Transfer Capacitance  | C <sub>rss</sub>     |   |        | 96   |      |      |
| Gate Resistance   | R <sub>g</sub>       | V <sub>GS</sub> = 15mV, V <sub>DS</sub> = 0V, f = 1MHz                                      |        | 1.0  |      | Ω    |
| Total Gate Charge <sup>1,2</sup>  | Q <sub>g</sub>       | V <sub>DS</sub> = 75V, V <sub>GS</sub> = 10V,<br>I <sub>D</sub> = 20A                       |        | 75   |      | nC   |
| Gate-Source Charge <sup>1,2</sup>   | Q <sub>gs</sub>      |   |        | 16   |      |      |
| Gate-Drain Charge <sup>1,2</sup>  | Q <sub>gd</sub>      |   |        | 28   |      |      |
| Turn-On Delay Time <sup>1,2</sup>   | t <sub>d(on)</sub>   | V <sub>DS</sub> = 75V,<br>I <sub>D</sub> = 20A, V <sub>GS</sub> = 10V, R <sub>GS</sub> = 6Ω |        | 22   |      | nS   |
| Rise Time <sup>1,2</sup>  | t <sub>r</sub>       |   |        | 60   |      |      |
| Turn-Off Delay Time <sup>1,2</sup>  | t <sub>d(off)</sub>  |   |        | 30   |      |      |
| Fall Time <sup>1,2</sup>  | t <sub>f</sub>       |   |        | 35   |      |      |
| <b>SOURCE-DRAIN DIODE RATINGS AND CHARACTERISTICS (T<sub>C</sub> = 25 °C)</b> |                      |   |        |      |      |      |
| Continuous Current  | I <sub>S</sub>       |   |        |      | 45   | A    |
| Pulsed Current <sup>3</sup>   | I <sub>SM</sub>      |   |        |      | 180  |      |
| Forward Voltage <sup>1</sup>  | V <sub>SD</sub>      | I <sub>F</sub> = 20A, V <sub>GS</sub> = 0V  |        |      | 1.2  | V    |
| Reverse Recovery Time   | t <sub>rr</sub>      | I <sub>F</sub> = 20A, dI <sub>F</sub> /dt = 100A / μS                                       |        | 120  |      | nS   |
| Reverse Recovery Charge   | Q <sub>rr</sub>      |   |        | 375  |      | nC   |

<sup>1</sup>Pulse test : Pulse Width ≤ 300 μsec, Duty Cycle ≤ 2%.

<sup>2</sup>Independent of operating temperature.

<sup>3</sup>Pulse width limited by maximum junction temperature.



TYPICAL CHARACTERISTICS

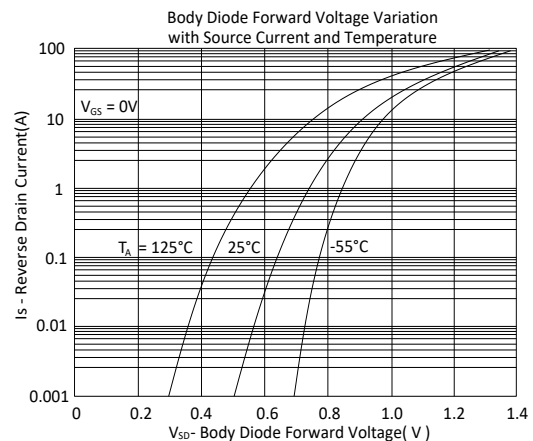
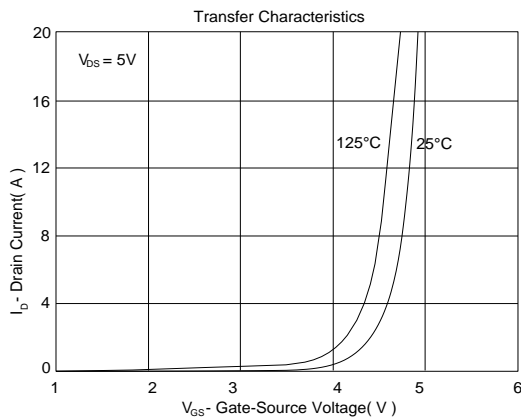
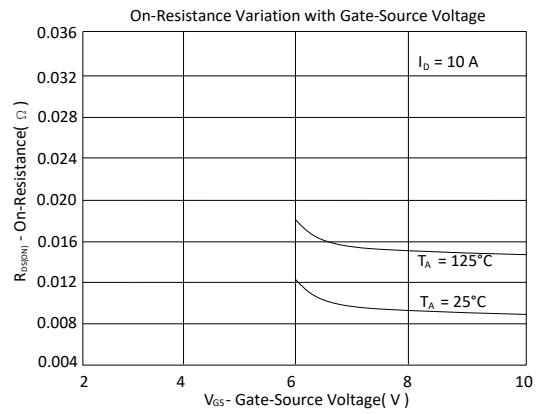
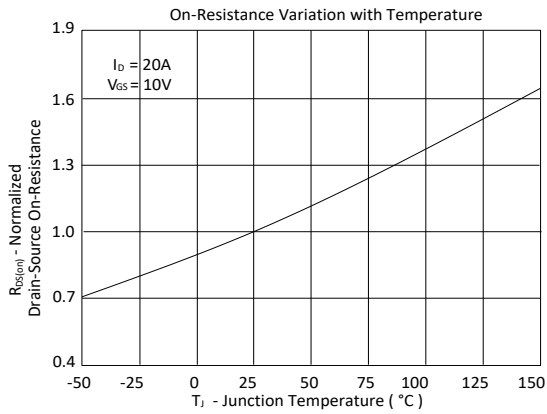
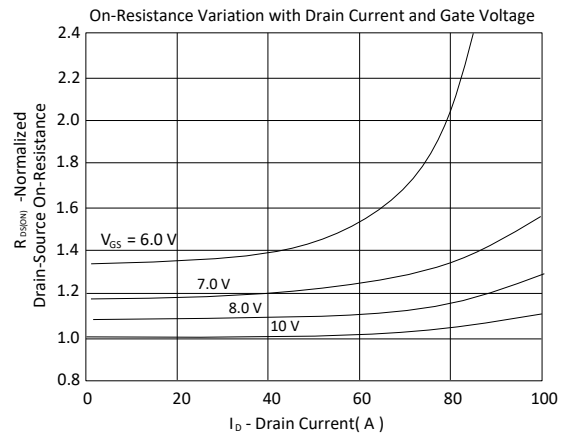
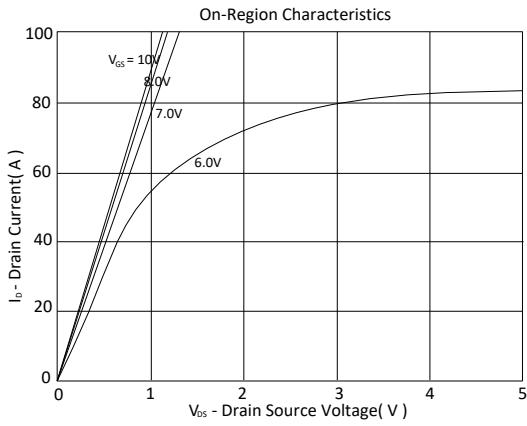

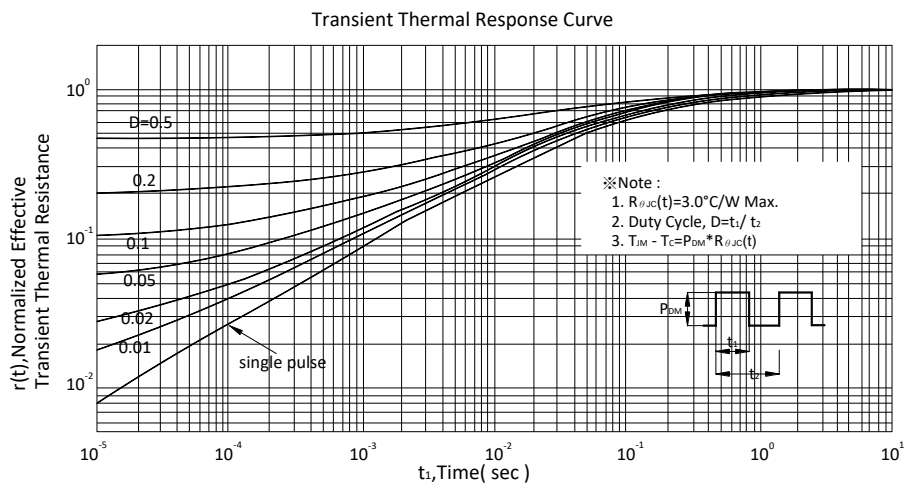
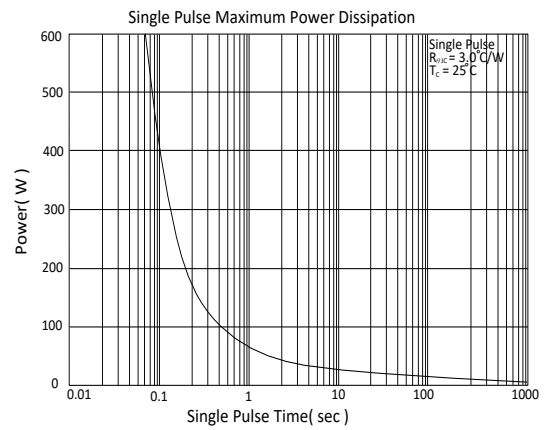
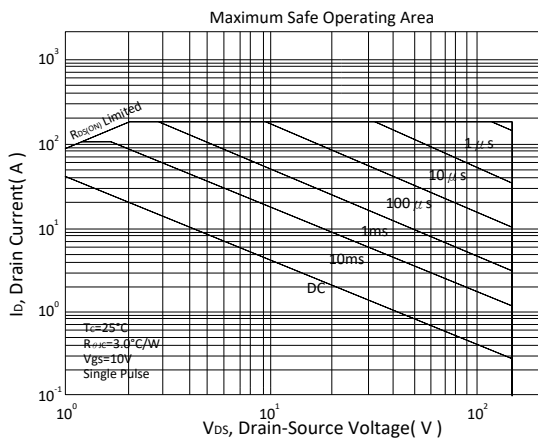
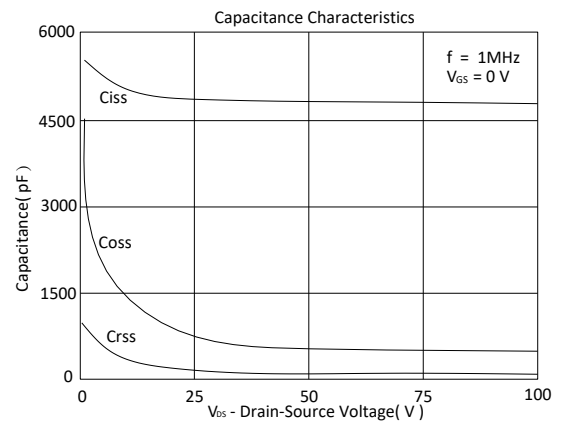
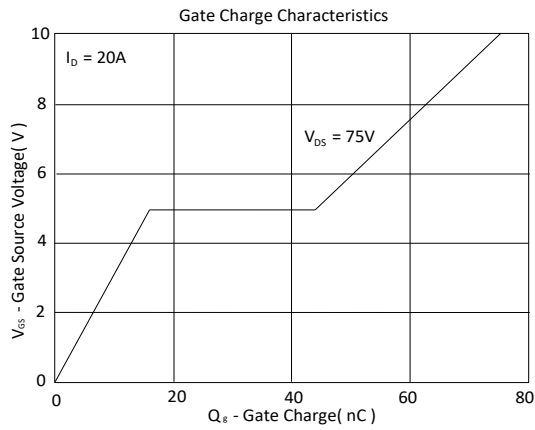



Ordering & Marking Information:

Device Name: EMD11N15F for TO-220F

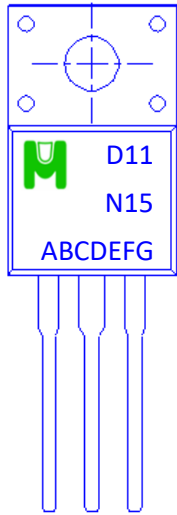

→ D11N15: Device Name

→ ABCDEFG: Date Code

A: Assembly House

B: Year(A:2008 B:2009 C:2010....)

C: Month(A:01 B:02 C:03 D:04 E:05 F:06 G:07 H:08 I:09 J:10 K:11 L:12)

DEFG: Serial No.

Outline Drawing

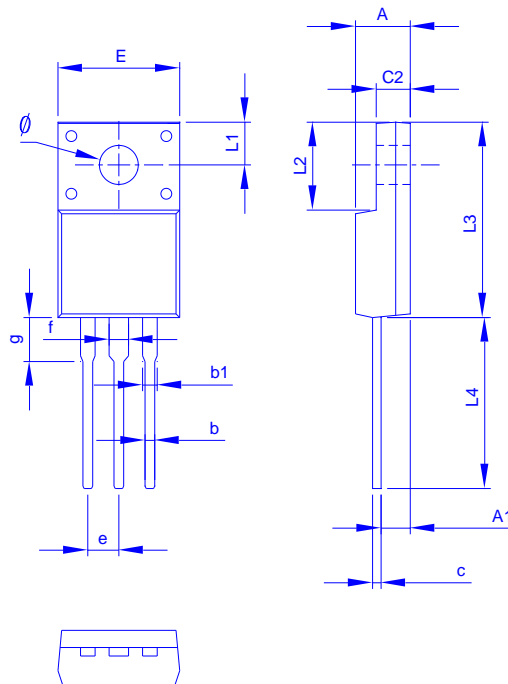

Dimension in mm

| Dimension | A   | A1   | b    | b1  | c    | c2   | E     | L1   | L2   | L3    | L4    | φ    | e    | f    | g    |
|-----------|-----|------|------|-----|------|------|-------|------|------|-------|-------|------|------|------|------|
| Min.      | 4.3 | 2.49 | 0.5  | 1.1 | 0.4  | 2.34 | 9.96  | 2.7  | 6.48 | 14.8  | 12.65 | 3    | 2.44 | 1.17 | 2.93 |
| Typ.      | 4.5 | 2.59 | 0.8  | 1.3 | 0.5  | 2.54 | 10.1  | 3.25 | 6.68 | 15.87 | 12.98 | 3.1  | 2.54 | 1.28 | 3.03 |
| Max.      | 4.9 | 2.96 | 0.95 | 1.6 | 0.75 | 3.2  | 10.36 | 3.45 | 6.9  | 16.2  | 13.5  | 3.38 | 2.64 | 1.75 | 4    |



◆ Tube Information: 50pcs/Tube (1000pcs/Box)

