

# Battery Powered, High Efficiency Synchronous DC/DC Boost Converter

## General Description

EMH7600 is designed with high efficiency step up DC/DC converter for portable devices applications. It features with extreme low 26µA quiescent current with no load which is the best fit for extending battery life during the standby mode.

The start-up voltage is 0.93V typically with operating voltage down to 0.7V. With Synchronous structure, it does not need any external Schottky diode. The peak current is limited to 1A for quick turn on. The EMH7600 is available in MSOP-8 package.

This product can provide 500mA load current and still maintained at least 70% efficiency and above 90% efficiency when at 100mA load current.

The EMH7600 is available in MSOP-8 package, With RoHS compliance.

## Features

- Single or dual battery operation
- Achieve 93% efficiency
- Output Current up to 500mA
- Reference voltage 1.195V
- Typical Iq 26µA with no load
- No Schottky diode needed
- Shutdown current < 1µA
- Excellent Line and Load Transient Response
- On-Chip Low Battery Detector ( MSOP-8 package)

## Applications

- Blue-Tooth devices
- Cellular and Smart Phones
- Personal multi-media Player (PMP)
- Wireless networking
- Hand-Held Devices with 1 to 3-Cell of NiMH/NiCd Batteries
- Digital Still Cameras
- Portable applications

## Typical Application

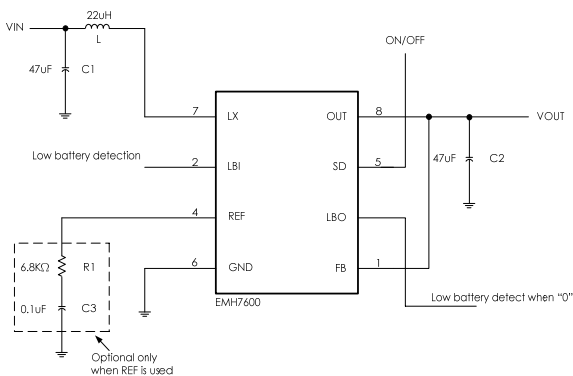

Fig. 1

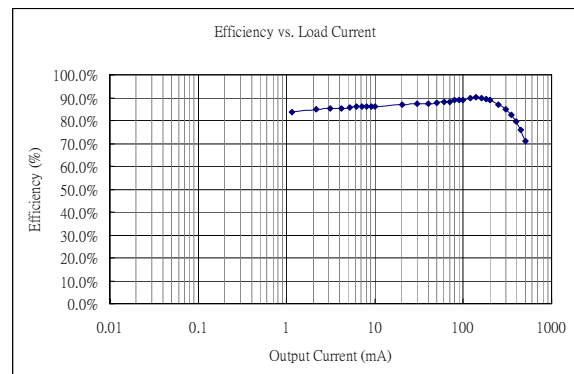
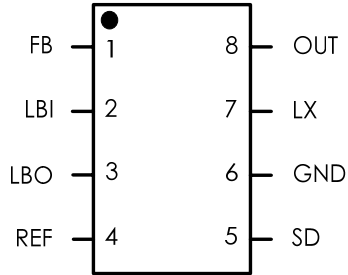

Fig. 2

## Package configuration

MSOP-8



## Order information

EMH7600-00MA08GRR/NRR

00	Adjustable output voltage
MA08	MSOP-8 Package
GRR	RoHS (Pb Free) Rating: -40 to 85°C Package in Tape & Reel
NRR	RoHS & Halogen free (By Request) Rating: -40 to 85°C Package in Tape & Reel

## Order, Mark & Packing Information

Package	Product ID	Vout	Marking	Packing
MSOP-8	EMH7600-00MA08GRR	00 (adjustable)		3K units Tape & Reel

## Pin Functions

Pin Name	MSOP-8 Pin#	Function
FB	1	Connecting to OUT to get +3.3V output, Connecting to GND to get +5.0V output, Using resistor network to set the output voltage from +1.8V to +5.5V.
LBI	2	Low-battery comparator input. Internally set at +1.195V+50mV to trip
LBO	3	Open-drain low battery comparator output. Output is low when $V_{LBI}$ is <1.195V. LBO is high impedance during shutdown.
REF	4	1.195V Output. In Case of driving load, Need R and C for stability
SD	5	Shutdown input. "1" is enabled and "0"=shutdown
GND	6	Ground Pin.
LX	7	Switch Pin. Must be connected to Inductor.
OUT	8	Output Voltage Pin. This also provides bootstrap power to the IC.

## Absolute Maximum Ratings

Devices are subjected to failure if they stay above absolute maximum ratings.

Input Voltage	-0.3V to 6V	Peak Switch Sink and Source Current	1.5A
SD, V <sub>FB</sub> Voltages	-0.3V to V <sub>IN</sub>	Operating Temperature Range	-40°C to 85°C
LX Voltage	-0.3V to (V <sub>IN</sub> + 0.3V)	Junction Temperature (Notes 1, 3)	125°C
PMOS Switch Source Current (DC)	0.5A	Storage Temperature Range	-65°C to 150°C
NMOS Switch Sink Current (DC)	0.5A	Lead Temperature (Soldering, 10 sec)	260°C

### ESD Susceptibility

HBM	2kV
MM	200V

### Thermal Resistance

θ <sub>JC</sub> (MSOP)	56°C/W
θ <sub>JA</sub> (MSOP)	190°C/W

## Electrical Characteristics

V<sub>IN</sub>=2.0V, V<sub>OUT</sub>=3.3V, FB=V<sub>OUT</sub>, T<sub>A</sub>=25 °C, unless otherwise specified

PARAMETER	TEST CONDITION	MIN	TYP	MAX	UNIT
Minimum input voltage			0.7		V
Operating Voltage		1.1		5.5	V
Start-up Voltage	RL=3K		0.93	1.00	V
Start-up Voltage Tempco			-2		mV/°C
Output Voltage Range	V <sub>in</sub> <V <sub>out</sub>	1.8		5.5	
Output Voltage	FB=V <sub>out</sub>	3.17	3.3	3.43	V
Steady State Output Current	FB=V <sub>out</sub>	300	350		mA
	FB=GND	180	230		mA
Reference Voltage	I <sub>ref</sub> =0	1.16	1.195	1.225	V
Reference Voltage Tempco	Temp=-40°C to 85°C		0.015		mV/°C
Reference Load Regulation	I <sub>ref</sub> =0 to 100µA		1	30	mV
Reference Line Regulation	V <sub>out</sub> =1.8V to 5.5V		0.3	5	mV/V
FB, LBI Input Threshold		1.16	1.195	1.225	V
Internal switch On-Resistance	ILX=100mA		0.4		ohm
LX switch Current Limit			1		A
LX Leakage Current	VLX=0V~4V; V <sub>out</sub> =5.5V		0.05	1	µA
Operating Current into OUT	V <sub>FB</sub> =1.4V, V <sub>out</sub> =3.3V		26	40	µA
Shutdown Current into OUT	SD=GND		0.1	1	µA
Efficiency	V <sub>out</sub> =3.3V, I <sub>load</sub> =200mA		90		%
	V <sub>out</sub> =2V, I <sub>load</sub> =1mA		85		
LX Switch On-Time	V <sub>FB</sub> =1V, V <sub>out</sub> =3.3V	2	4	7	µs
LX Switch Off-Time	V <sub>FB</sub> =1V, V <sub>out</sub> =3.3V	0.6	0.9	1.4	µs
FB Input Current	V <sub>FB</sub> =1.4V		0.03	50	nA
LBI Input Current	VLBI=1.4V		1	50	nA
SD Input Current	VSD=0 or V <sub>out</sub>		0.07	50	nA
LBOB Low Output Voltage	VLBI=0, I <sub>sink</sub> =1mA		0.2	0.4	V

LBOB Off Leakage Current	VLBOB=5.5V,VLBI=5.5V		0.07	1	nA
LBI Hystereisis			50		mV
SD Input Voltage (*when SD="L" , Vout=Vin)	VIL			0.2Vin	V
	VIH	0.8Vout			

**Note 1:** Specifications are tested at  $T_A=25^{\circ}\text{C}$ . Specifications over temperature range are guarantee by design, characterization and correlation with Statistical Quality Controls (SQC).

**Note 2:** Start-up voltage operation is guaranteed without external Schottky diode

**Note 3:** Steady-state output current indicates that the device maintains regulation under load.

**Note 4:** Device is bootstrapped (power to the IC comes from OUT). This correlates directly with the actual battery supply.

## Typical Performance Characteristics

$V_{in}=2.4V$ ,  $V_{out}=3.3V$  unless otherwise specified

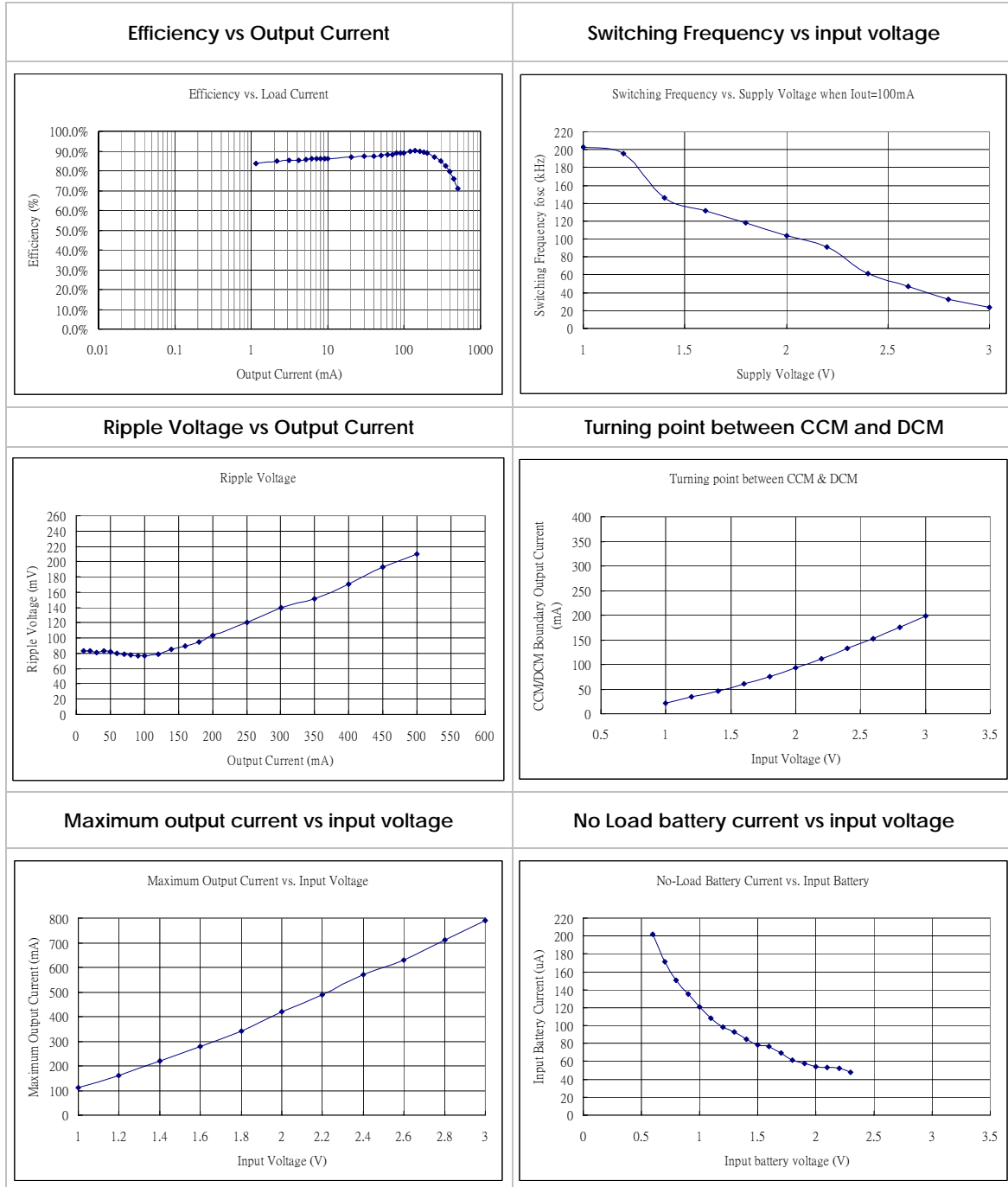

## Typical Performance Characteristics

Vin=2.4V, Vout=3.3V unless otherwise specified

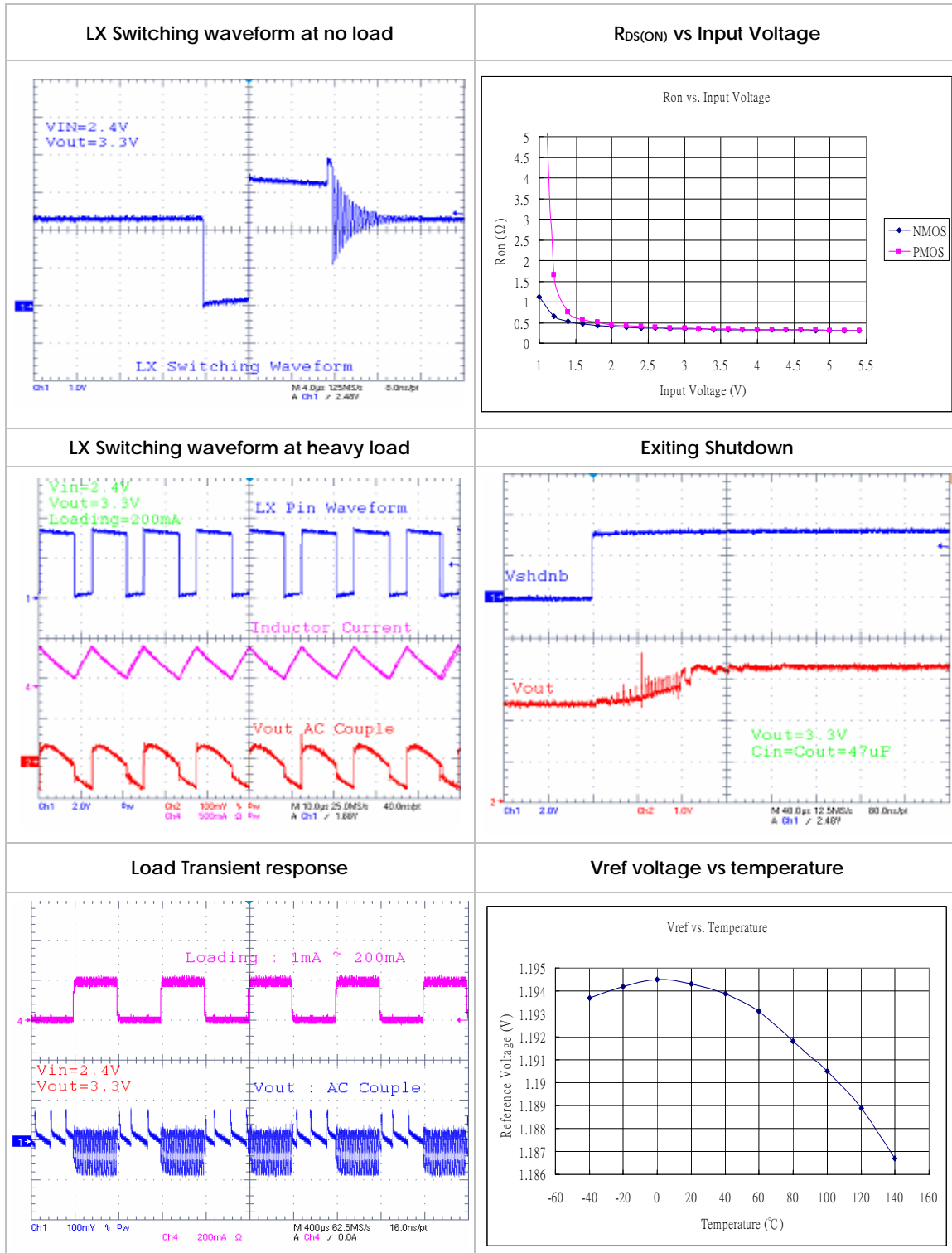

## Typical Performance Characteristics

Vin=2.4V, Vout=3.3V unless otherwise specified

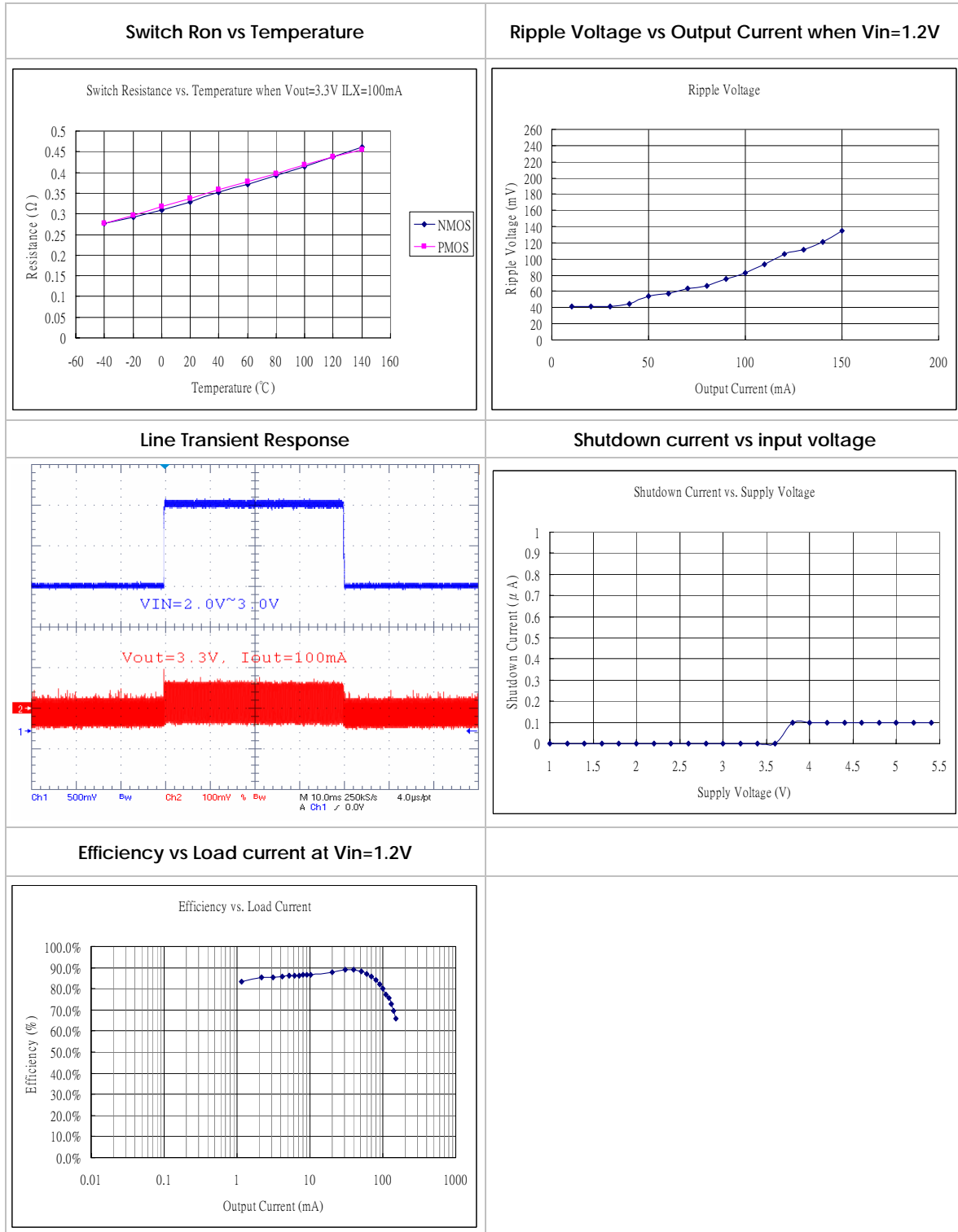

## Functional Block Diagram

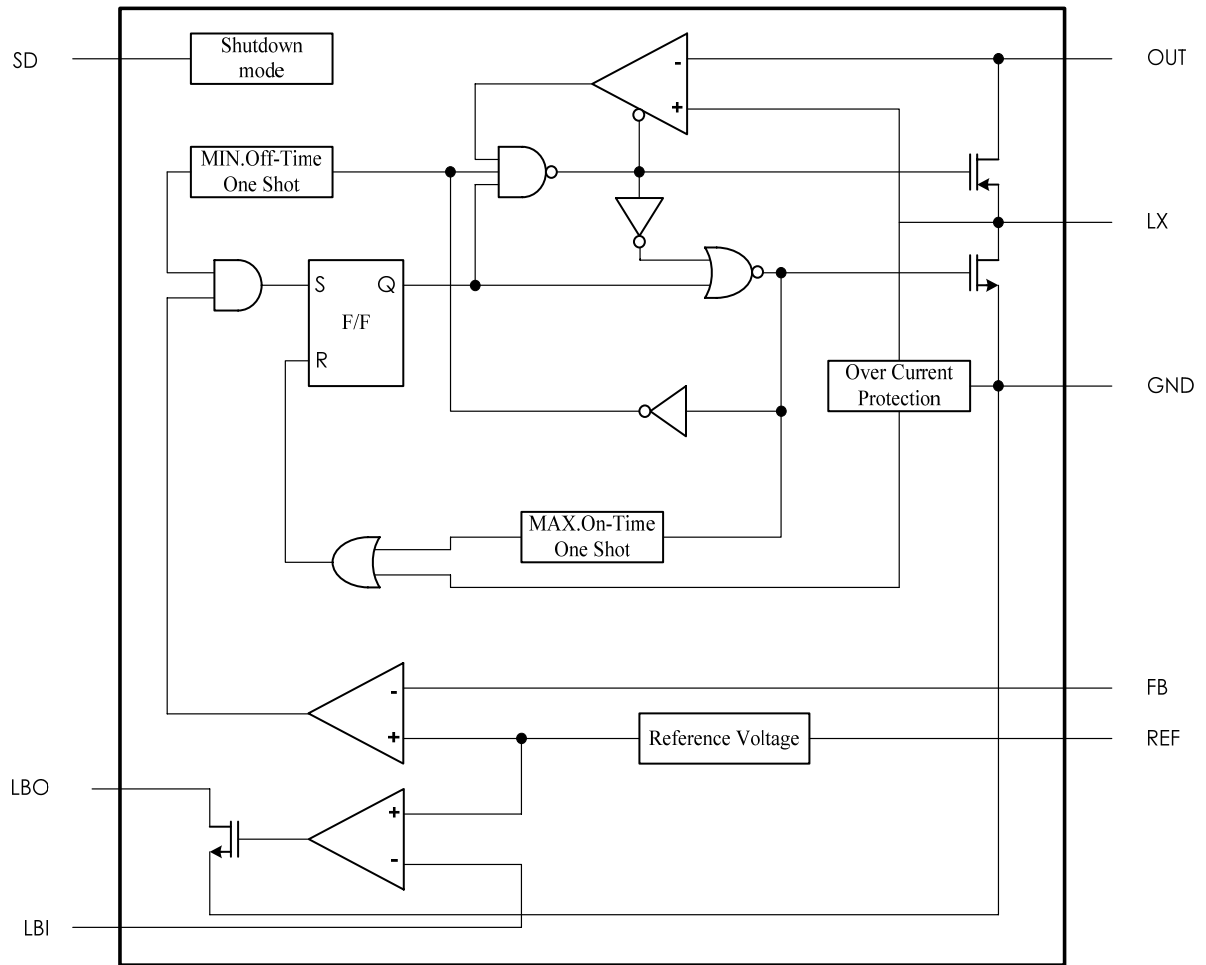

EMH7600 Block diagram



## Applications

### Overview

EMP7600 is high efficiency, step-up DC-DC converters, designed to feature a built-in synchronous rectifier, which reduces size and cost by eliminating the need for an external Schottky diode. The start-up voltage is as low as 0.93V and it operates with an input voltage down to 0.7V. Quiescent supply current is only 26 $\mu$ A. The internal P-MOSFET on resistance is typically 0.4 $\Omega$  to improve overall efficiency by minimizing AC losses. The output voltage can be easily set by two external resistors from 1.8V to 5.5V, connecting FB to OUT to get 3.3V, or connecting to GND to get 5.0V. The current limit is 1A still it can reliably provide up to 500mA load current and still maintained a decent efficiency.

### PFM Control Scheme

The key feature of the design is to apply a unique minimum off-time, constant on-time and current-limited Pulse Frequency Modulation (PFM) control scheme (see BLOCK DIAGRAM) with the ultra-low quiescent current. The peak current of the internal N MOSFET power switch can be fixed at 1.0A. The switching frequency can be up to 200KHz depending on the loading current. The minimum off-time is 1 $\mu$ S and the maximum on-time is 4 $\mu$ S.

### Synchronous Rectification

With the internal synchronous rectifier, it eliminates the need for an external Schottky diode. This saves the cost and board space. During the cycle of off-time, P-MOSFET turns on and shunts N- MOSFET. Due to the low turn-on resistance of MOSFET, synchronous rectifier significantly improves efficiency without an additional external Schottky diode. Thus, the conversion efficiency can be as high as 93%.

The reference voltage (REF) is nominally 1.195V with excellent temperature performance. In addition, REF pin can source up to 10 $\mu$ A to external circuit with good load regulation (<10mV). A bypass capacitor of 0.1 $\mu$ F in series with 6.8k $\Omega$  resistor is required for proper operation and good stability. If no loading requirement, this R and C are not required at all.

### Shutdown

The device is in shutdown mode when  $V_{SD}$  is low. At shutdown mode, the current can flow from battery to output due to body diode of the P-MOSFET.  $V_{OUT}$  falls to approximately  $V_{in}-0.6V$  and LX remains in high impedance. The Cload and load current at OUT determine the rate of how  $V_{OUT}$  decays. Shutdown can be pulled as high as 6V regardless of the voltage at OUT.

## Reference Voltage

## Applications (continued)

### Selecting the Output Voltage

V<sub>OUT</sub> can be simply set to 3.3V/5.0V by connecting FB pin to OUT/GND due to the use of internal resistor divider in the IC. In order to adjust output voltage, a resistor divider is connected to V<sub>OUT</sub>, FB, GND. The V<sub>out</sub> can be calculated by the following equation:

$$R5=R6 [(V_{OUT} / V_{REF}) - 1] \dots\dots\dots(1)$$

Where V<sub>REF</sub> =1.195V and V<sub>OUT</sub> is ranging from 1.8V to 5.5V. The recommended R6 is 240KΩ.

## Component Selection

### 1. Inductor Selection

An inductor value of 22μH performs well in most applications. The device also works with inductors in the 10μH to 47μH range. An inductor with higher peak inductor current tends a higher output voltage ripple (I<sub>PEAK</sub>×output filter capacitor ESR). The inductor's DC resistance significantly affects efficiency. We can calculate the maximum output current as follows:

$$I_{OUT(MAX)} = \frac{V_{IN}}{V_{OUT}} \left[ I_{LIM} - t_{OFF} \left( \frac{V_{OUT} - V_{IN}}{2 \times L} \right) \right] \eta \dots\dots\dots(2)$$

where I<sub>OUT</sub> (MAX)=max. output current in amps

V<sub>IN</sub>=input voltage

L = inductor value in μH

η = efficiency (typically 0.9 )

t<sub>OFF</sub> = LX switch' off-time in μS

I<sub>LIM</sub> =1.0A

### 2. Capacitor Selection

The output ripple voltage relates with the peak inductor current and the output capacitor's ESR. Besides output ripple voltage, the output ripple current also needs to be concerned. A filter capacitor with low ESR is helpful to the efficiency and steady state output current. A smaller capacitor (down to 47μF with higher ESR) is acceptable for light loads or in applications of which can tolerate higher output ripple.

### 3. PCB Layout and Grounding

Since EMH7600's switching frequency can range up to 200kHz, it is sensitive to how PCB is layout. PCB layout is important for minimizing ground bounce and noise. The GND pin should be placed close to the ground plane. Keep the IC's GND pin and the ground leads of the input and output filter capacitors as short as possible. In addition, keep all connections to the FB and LX pins as short as possible. In particular, in case of using external feedback resistors, locate them as close to the FB as possible. To maximize output power and efficiency and minimize output ripple voltage, use a ground plane right under the soldered IC.

### Ripple Voltage Reduction

The output ripple voltage can be significant improved by using two or three parallel output capacitors. The addition of an extra input capacitor also results in a stable output voltage.

## Application (Continued)

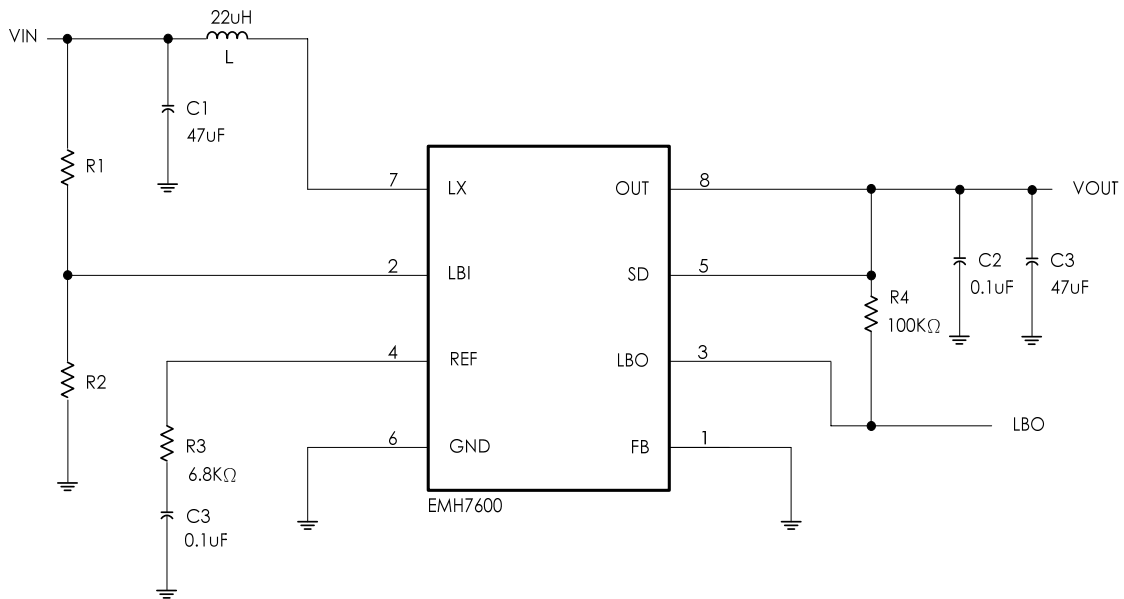

Application circuit for  $V_{OUT} = 5V$

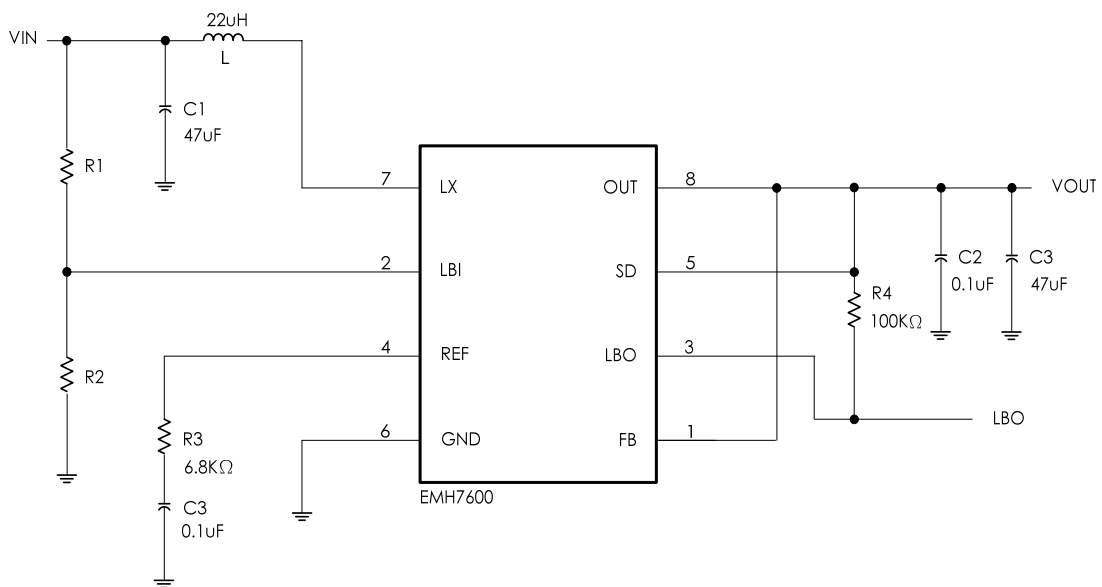

Application circuit for  $V_{OUT} = 3.3V$

## Application (Continued)

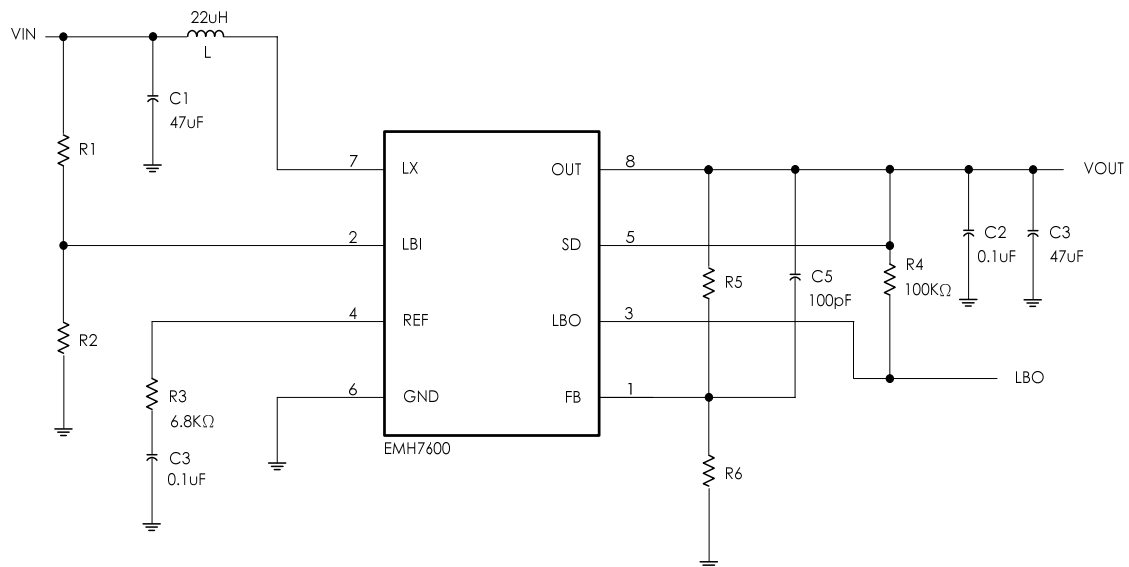

Application circuit for adjustable  $V_{OUT}$  using formula  $(R5+R6)/R6 * 1.195$

## Typical schematic for PCB layout

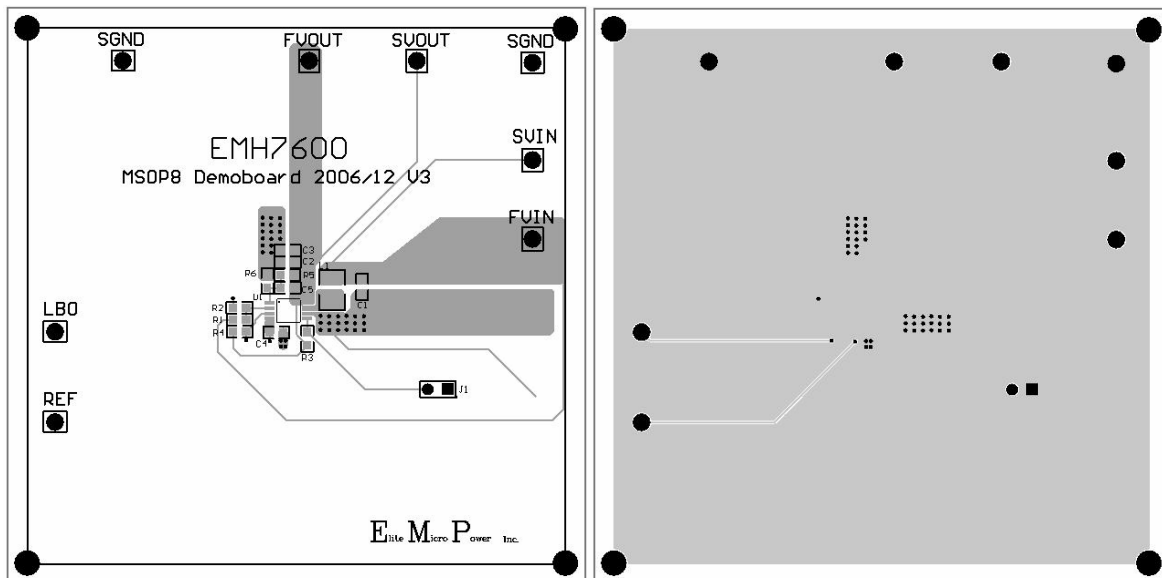
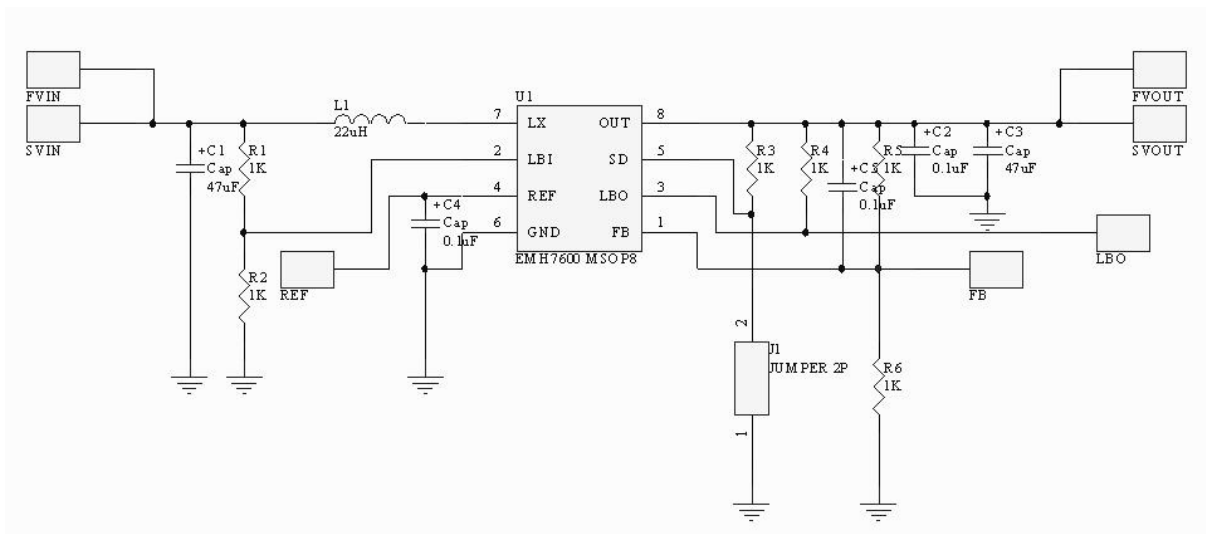

## Package Information

### MSOP-8 Plastic Package

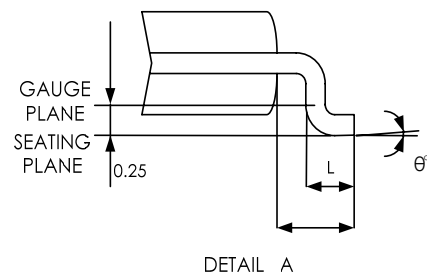
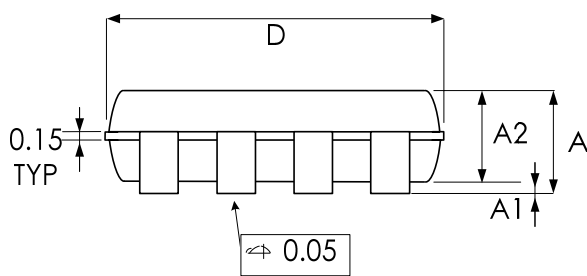
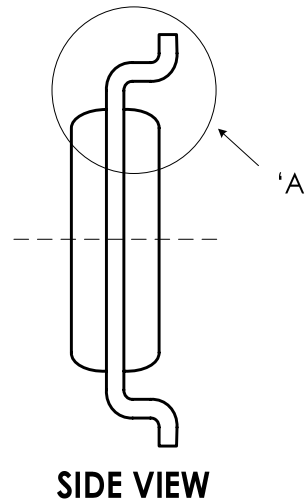
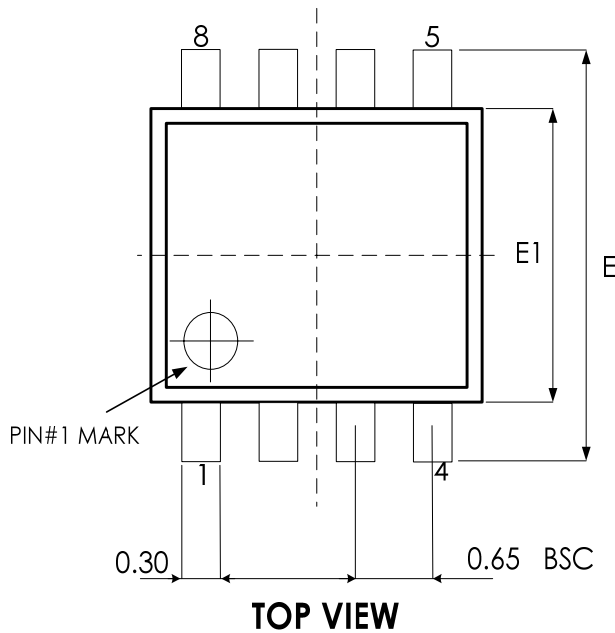

### BOTTOM VIEW

SYMBPLS	MIN.	NOM.	MAX.
A	—	—	1.1
A1	0	—	0.15
A2	0.75	0.85	0.95
D	3.00 BSC		
E	4.90 BSC		
E1	3.00 BSC		
L	0.4	0.6	0.8
L1	0.95 BSC		
θ°	0	—	8

UNIT: MM

## Notice

## Order, Mark & Packing Information

Package	Product ID	Vout	Marking	Packing
MSOP-8	EMH7600-00MA08GRR	00 (adjustable)	H100 Date Code	3K units Tape & Reel
MSOP-8	EMH7600-00MA08GRR	00 (adjustable)	H7600 Date Code	3K units Tape & Reel
MSOP-8	EMH7600-00MA08GRR	00 (adjustable)	EMP H7600 Date Code	3K units Tape & Reel

## Revision History

Revision	Date	Description
2.0	2009.06.05	EMP transferred from version 1.1



## Important Notice

All rights reserved.

No part of this document may be reproduced or duplicated in any form or by any means without the prior permission of ESMT.

The contents contained in this document are believed to be accurate at the time of publication. ESMT assumes no responsibility for any error in this document, and reserves the right to change the products or specification in this document without notice.

The information contained herein is presented only as a guide or examples for the application of our products. No responsibility is assumed by ESMT for any infringement of patents, copyrights, or other intellectual property rights of third parties which may result from its use. No license, either express, implied or otherwise, is granted under any patents, copyrights or other intellectual property rights of ESMT or others.

Any semiconductor devices may have inherently a certain rate of failure. To minimize risks associated with customer's application, adequate design and operating safeguards against injury, damage, or loss from such failure, should be provided by the customer when making application designs.

ESMT's products are not authorized for use in critical applications such as, but not limited to, life support devices or system, where failure or abnormal operation may directly affect human lives or cause physical injury or property damage. If products described here are to be used for such kinds of application, purchaser must do its own quality assurance testing appropriate to such applications.