

3A, 36V, 1.5MHz Non-synchronous Step-Down Converter

General Description

The EML3193 is frequency adjustable, 3A, current-mode step-down converter with an integrated high-side switch. The EML3193 operates with the wide input voltage from 4.5V to 36V and provides an adjustable output voltage from 0.808V to 30V. The EML3193 features a PWM mode operation with up to 1.5MHz adjustable switching frequency. The EML3193 also provides a highly efficient solution with current mode control for fast loop response and easy compensation. The EML3193 automatically enters PSM mode at light load.

Cycle-by-cycle current limiting and thermal shutdown are provided for fault condition protections. An internal 2ms soft-start design reduces input start-up current and prevents the output voltage and inductor current from overshooting during power-up.

The EML3193 is available in E-SOP-8L with thermally enhanced package.

Typical Application

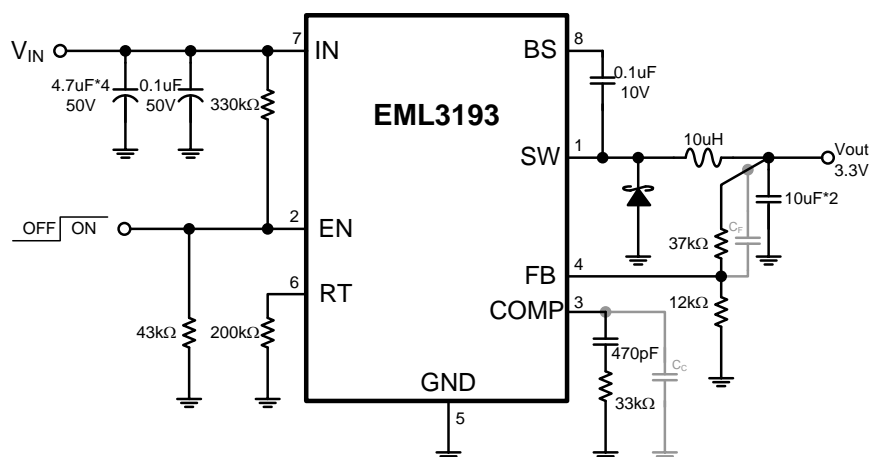

Fig.1

Features

- 4.5V to 36V Input Voltage Range
- 3A Continuous Output Current
- 65mΩ Internal Power MOSFET Switch
- Output Adjustable from 0.808V
- Up to 1.5MHz Adjustable Switching Frequency
- Cycle-by-Cycle Current Limit, Frequency Fold Back and thermal shutdown
- Stable with Low ESR Output Ceramic Capacitors
- 2ms Internal Soft-Start
- Thermally Enhanced E-SOP-8L Package

Applications

- 12V and 24V Distributed Power Systems
- Battery Powered Systems
- Industrial Power Systems
- LCD and Plasma TVs
- Automotive Systems

Package Configuration

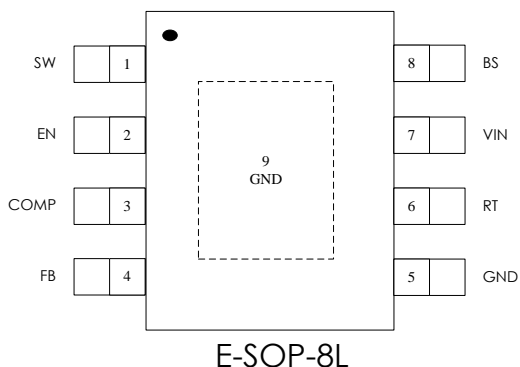

EML3193-00SG08NRR
 00 Adjustable
 SG08 E-SOP-8L Package
 NRR RoHS & Halogen free package
 Commercial Grade Temperature
 Rating: -40 to 85°C
 Package in Tape & Reel

Order, Mark & Packing information

Package	Vout(V)	Product ID	Marking	Packing
E-SOP-8L	Adjustable	EML3193-00SG08NRR		Tape & Reel 3K units

Functional Block Diagram

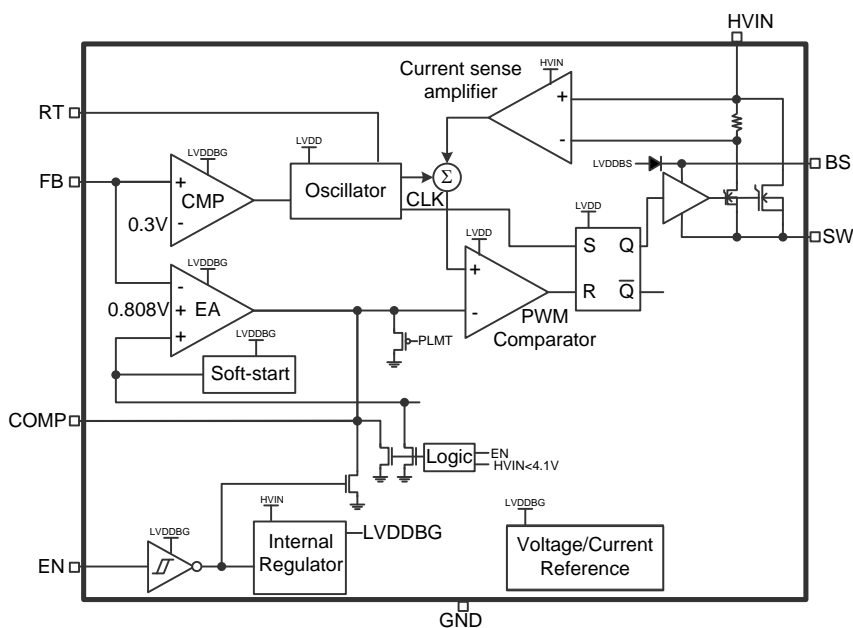

Fig.2

Pin Functions

Pin Name	E-SOP-8L	Function
SW	1	Switch Out. This is the output from the high-side switch.
EN	2	Enable Pin. On/Off control Input.
COMP	3	Compensation. This node is the output of Error Amplifier. Control loop frequency compensation is applied to this pin.
FB	4	Feedback Pin. This pin can be connected a resistor divider to set the output voltage range.
GND	5	Ground Pin. Connect exposed pad to GND plane for optimal thermal performance.
RT	6	Frequency setting pin. This pin can be connected to a resistor to GND to set the oscillator frequency.
VIN	7	Supply Voltage. The EML3193 operates from a 4.5V to 36V.
BS	8	Bootstrap. This is the positive power supply for the internal floating high-side MOSFET driver. Connect a bypass capacitor (0.1uF) between BS and SW.
GND	9	Ground Pin/Thermal Pad This Pin must be connected to ground. The thermal pad with large thermal land area on the PCB will helpful chip power dissipation.

Absolute Maximum Ratings

Devices are subjected to fail if they stay above absolute maximum ratings.

Input Voltage(V _{IN}) -----	- 0.3V to +42V	Lead Temperature (Soldering, 10 sec) -----	260°C
Switch Voltage (S _W) -----	- 0.3V to V _{IN} +0.3V	Junction Temperature (Notes 1) -----	-40°C to 150°C
Boost Voltage (B _S)-----	V _{SW} -0.3V to V _{SW} +6V	Storage Temperature Range -----	- 65°C to 150°C
Enable Voltage (E _N) -----	- 0.3V to V _{IN}	ESD Susceptibility HBM -----	2KV
All Other Pins (RT, FB, COMP) -----	- 0.3V to +6V	MM -----	200V

Recommended Operating Conditions

Input Voltage(V _{IN}) -----	+4.5V to +36V	Junction Operating Temperature Range -----	-40°C to 125°C
---------------------------------------	---------------	--	----------------

Thermal data

Package	Thermal resistance	Parameter	Value
E-SOP-8L	θ_{JA} (Note 2)	Junction-to-ambient	50°C/W
	$\theta_{JC(top)}$ (Note 3)	Junction-case (top)	39°C/W
	$\theta_{JC(bottom)}$ (Note 4)	Junction-case (bottom)	10°C/W

Electrical Characteristics

V_{IN}=12V, T_A=+25°C, unless otherwise specified.

Symbol	Parameter	Conditions	Min	Typ	Max	Units
V _{FB}	Feedback Voltage	4.5V ≤ V _{IN} ≤ 36V	0.788	0.808	0.828	V
R _{DS(ON)}	Switch on Resistance			65	100	mΩ
I _{SW}	High-side Switch Leakage	V _{EN} =0V, V _{SW} =0V			10	μA
I _{LIM}	Current Limit	F _{OSC} =200KHz		6.8		A
G _{CS}	COMP to Current Sensing Transconductance (note5)			9		A/V
A _{EA}	Error Amplifier Voltage Gain (note5)			200		V/V
G _{EA}	Error Amplifier Transconductance (note5)	I _{COMP} =±3uA		68		uA/V
	Error Amplifier Min Source Current	FB=0.7V		5		uA
	Error Amplifier Min Sink Current	FB=0.9V		-5		uA
V _{UVLO}	VIN UVLO Threshold		3.9	4.2	4.5	V
	VIN UVLO Hysteresis			800		mV
F _{OSC}	Oscillation Frequency	V _{FB} =0.6V; RT=200kΩ	400	500	600	kHz
	Fold-Back Frequency	V _{FB} =0V; RT=200kΩ	50	125	175	kHz
I _{SD}	Shutdown Supply Current	V _{EN} =0		10	20	μA
I _Q	Quiescent Supply Current	V _{EN} =2V, No load, switching supply current		0.6	0.8	mA
		V _{EN} =2V, V _{FB} =1V, nonswitching supply current		0.5	0.7	mA
T _{SD}	Thermal Shutdown			150		°C
	Thermal Shutdown Hysteresis			20		°C

Symbol	Parameter	Conditions	Min	Typ	Max	Units
T _{OFF}	Minimum Off Time (note5)			200		ns
T _{ON}	Minimum On Time (note5)			100		ns
	EN Input Low Voltage				0.4	V
	EN Input High Voltage		1.2			V

Note 1: T_J is a function of the ambient temperature T_A and power dissipation P_D ($T_J = T_A + (P_D) \cdot \theta_{JA}$).

Note 2: θ_{JA} is simulated in the natural convection at T_A=25°C on a highly effective thermal conductivity (thermal land area completed with >3x3cm² area) board (2 layers , 2S0P) according to the JEDEC 51-7 thermal measurement standard.

Note 3: $\theta_{JC(top)}$ represents the heat resistance between the chip junction and the top surface of package.

Note 4: $\theta_{JC(bottom)}$ represents the heat resistance between the chip junction and the center of the exposed pad on the underside of the package.

Note 5: Guaranteed by design.

Typical Performance Characteristics

$V_{IN}=12V$, $V_{OUT}=3.3V$, $T_A=25^{\circ}C$, unless otherwise specified.

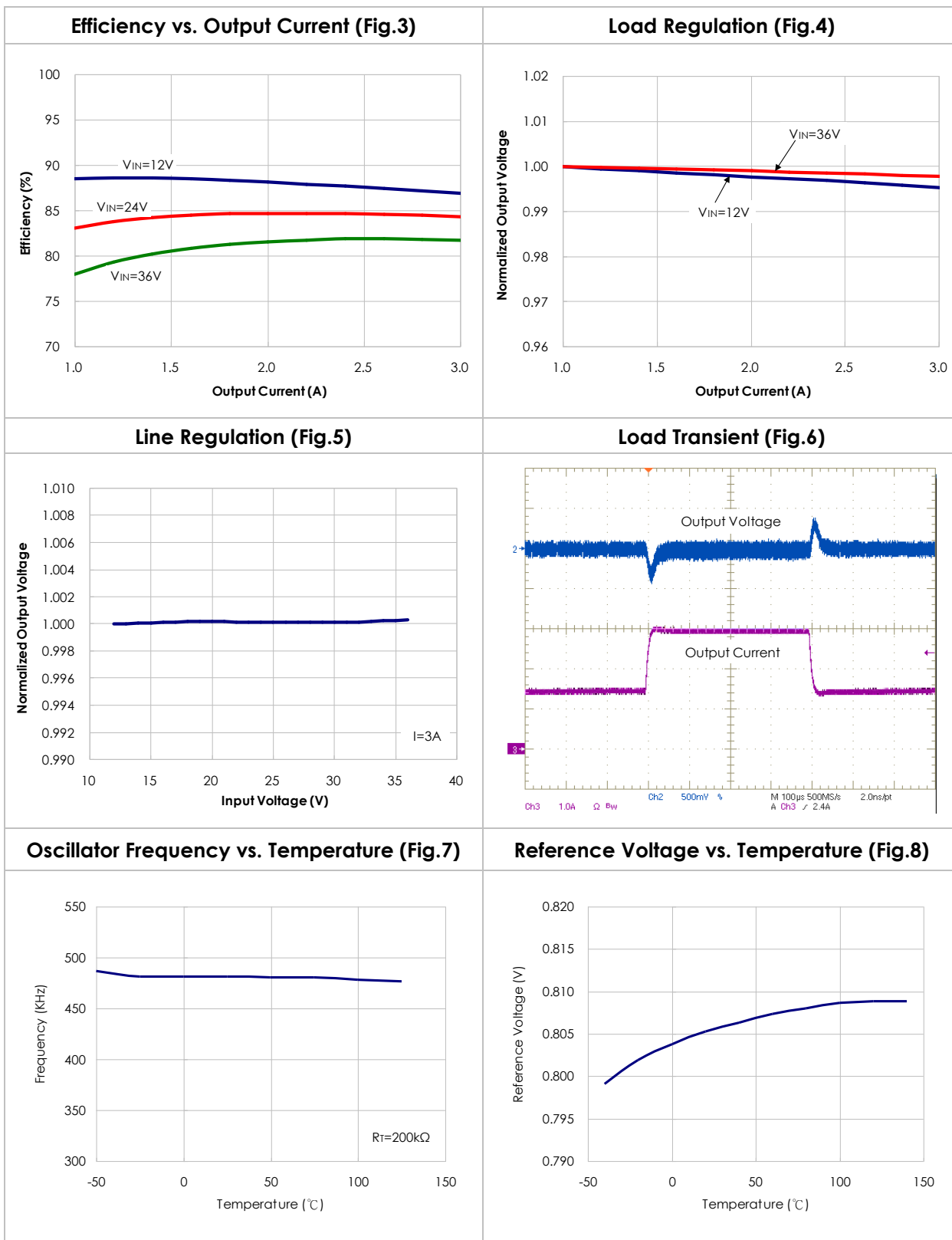

Typical Performance Characteristics

$V_{IN}=12V$, $V_{OUT}=3.3V$, $T_A=25^{\circ}C$, unless otherwise specified.

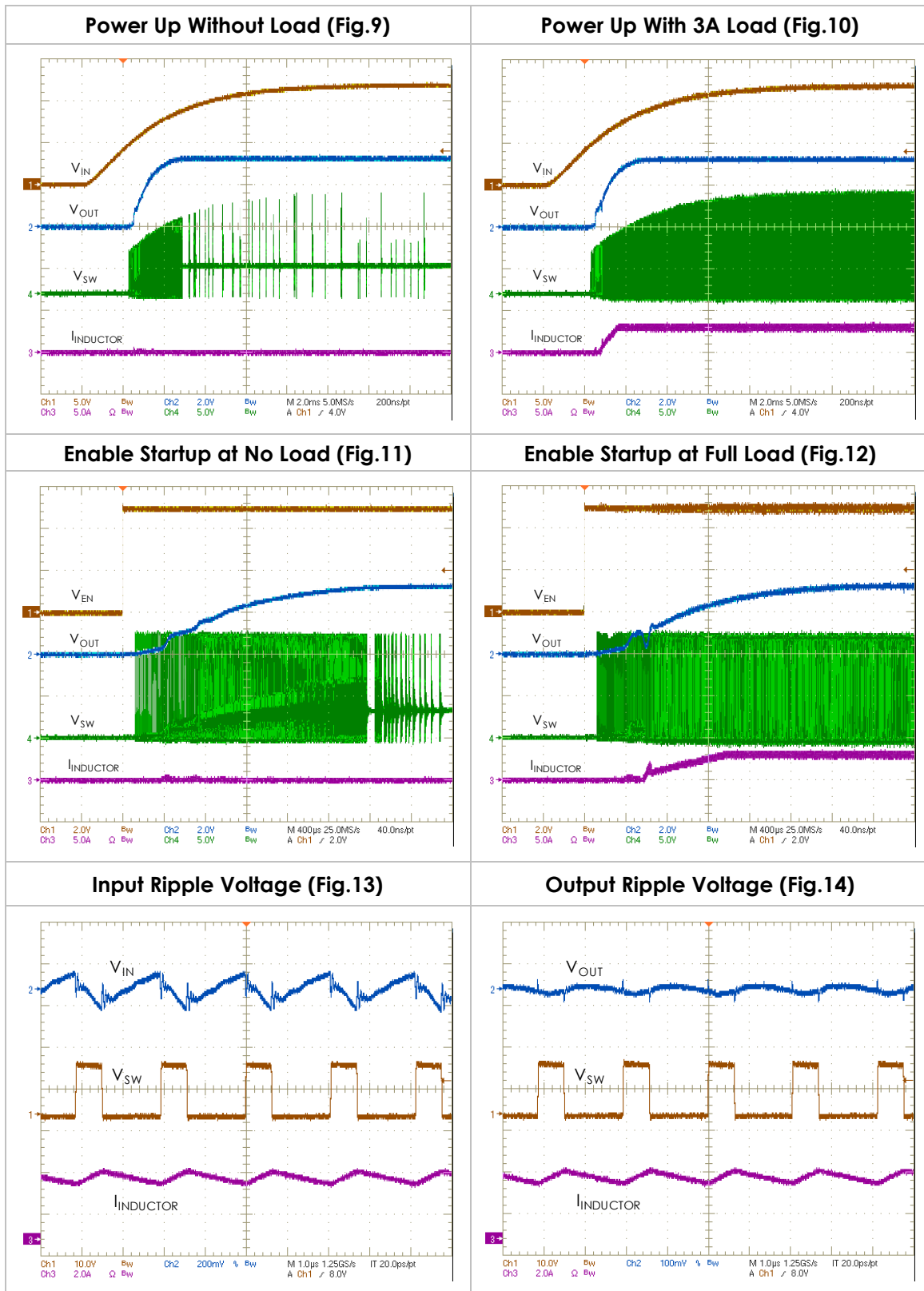

Detailed Description

The EML3193 is a variable frequency, current mode, automotive buck converter with an integrated high-side switch. The device operates with input voltages from 4.5V to 36V and tolerates input transients up to 42V. During light-load conditions, the device enters Pulse Skip Mode, automatically.

Wide Input Voltage Range (4.5V to 36V)

The EML3193 includes two separate supply inputs, VIN and BS, specified for a wide 4.5V to 36V input voltage range. VIN provides power to the device and BS provides power to the internal high-side switch driver. With respect to PWM minimum duty limit in EML3193, the safe operating voltage area shall be considering in here. The Safe Operating Voltage Area (SOVA) is showed in the fig.15.

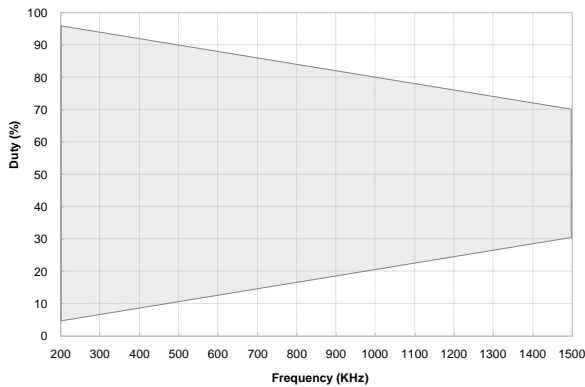

Fig.15 EML3193 Safe Operating Voltage Area

Error Amplifier

The error amplifier compares the FB pin voltage with the internal 0.80V reference and outputs a current proportional to the difference between the two. This output current is then used to charge or discharge the external compensation network on COMP pin to form the COMP voltage, which is used to control the power MOSFET current. During operation, the COMP voltage is range from 0.2V to 2.0V. COMP is internally pulled down to GND in shutdown mode. The voltage over 2.6V on COMP pin is not allowed due to 2.6V internal power.

Minimum On-Time

The device features a 100ns minimum on-time that ensures proper operation at high switching frequency and high differential voltage between the input and the output.

Enable Control

The EML3193 has a dedicated enable control pin, EN. By pulling it high or low, that can be enabled and disabled. Tie EN to IN through a 100kΩ resistor for automatic start up. To disable the part, EN must be

pulled low for at least 5us. When floating, EN is pulled up to about 2.0V by an internal 1uA current source so it is enabled. To pull it down, >10uA current capability is needed.

Over-Temperature protection

Thermal overload protection limits the total power dissipation in the device. When the junction temperature exceeds 150°C, an internal thermal sensor shuts down the whole chip. The thermal sensor turns on the IC again after the junction temperature is cooled by 20°C

Under Voltage Lock-out (UVLO)

UVLO is implemented to protect the chip from operating at insufficient supply voltage. The UVLO rising threshold is about 4.2V while its falling threshold is about 3.4V. If a higher UVLO is required for a specified application, as the EN pin shown in Fig.16 below to adjust input voltage UVLO via two external resistors and a filter capacitor.

The EN enable threshold is around 1.0V (EN_{ON}), and with 100mV hysteresis window (EN_{OFF}) for shutdown. An internal pull-up current source I_E (0.9uA) is in default operating when EN pin floats. Once the EN pin voltage exceed the EN_{ON}, an additional 2.9 uA of hysteresis, I_H, is added. This additional current facilitates adjustable input voltage UVLO hysteresis. Use Equation (a) to set the external UVLO hysteresis voltage. Use Equation (b) to set the external UVLO start voltage. For example, choosing R₃=330kΩ and R₄=43kΩ, the external UVLO V_{UVLO_start} and V_{UVLO_stop} would be around 9V and 7V.

$$R_3 = \frac{V_{UVLO_start} - k \cdot V_{UVLO_stop}}{k \cdot 3.8u - 0.9u} \dots\dots\dots(a)$$

$$R_4 = \frac{EN_{on}}{\frac{V_{UVLO_start} - EN_{on}}{R_3} + 0.9u} \dots\dots\dots(b)$$

$$k = \frac{EN_{on}}{EN_{off}} = 1.1$$

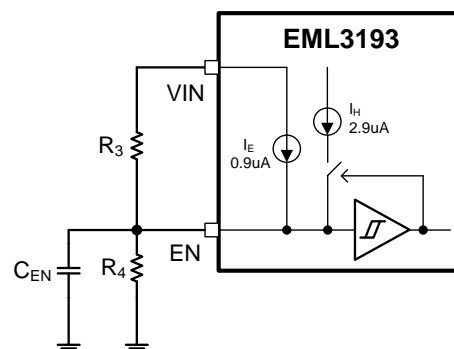

Fig.16 External UVLO Lock-out

Boost Capacitor

Connect a 1uF capacitor between the BS pin and SW pin. This capacitor provides the gate driver voltage for the high-side MOSFET. Also, an UVLO in the floating supply is implemented to protect the high-side MOSFET and its driver from operating at insufficient supply voltage. The UVLO rising threshold is about 2.2V while its hysteresis is about 0.16V.

Over-Current protection

Over-current limiting is implemented by sensing the drain-to-source voltage across the high-side MOSFET. The drain to source voltage is then compared to a voltage level representing the over-current threshold limit. If the drain-to-source voltage exceeds the over-current threshold limit, the over-current indicator is set true. Once over-current indicator is set true, over-current limiting is triggered. The high-side MOSFET is turned off for the rest of the cycle. The output voltage will start to drop if the output is dead-short to ground, suddenly. Once the FB is lower than 0.3V, the EML3193 is restarted periodically till the dead-short event is removed.

Programmable Oscillator

The EML3193 oscillating frequency (200kHz~1.5MHz adjustable switching frequency) is set by an external resistor, R_T from the RT pin to GND. The value of R_T can be calculated from:

$$Frequency(kHz) = \frac{7.5 \times 10^4}{R_T^{0.945}(k\Omega)}$$

Application Information

The schematic on the front page shows a typical application circuit. The IC can provide up to 3A output current at a 3.3V output voltage. For proper thermal performances, the exposed pad of the device must be soldered down to the PCB.

Setting the Output Voltage

The output voltage is set by the resistive voltage divider from the output voltage to FB pin. The voltage divider divides the output voltage down to the feedback voltage by the ratio

$$V_{fb} = V_{out} \times \frac{R2}{R1 + R2} \Rightarrow V_{out} = V_{fb} \times \frac{R1 + R2}{R2}$$

Table1-Resistor Selection for Common Output Voltages

Vout	R1 (kΩ)	R2 (kΩ)
1.8V	33.1 (1%)	27 (1%)
2.5V	50.2 (1%)	24 (1%)
3.3V	37 (1%)	12 (1%)
5.0V	62.3 (1%)	12 (1%)
12V	277 (1%)	20 (1%)

Selecting the Inductor

The common rule for determining the inductance to use is to allow the peak-to-peak ripple current in the inductor to be between 20% and 40% of the DC maximum load current, typical 30%. And also have sufficiently high saturation current rating and a DCR as low as possible. Generally, it is desirable to have lower inductance in switching power supplies, because it usually corresponding to faster transient response, smaller DCR and reduced size for more compact designs. But too low of an inductance results in higher ripple current such that over-current protection at full load could be falsely triggered. Also, the output ripple voltage and efficiency become worse with lower inductance. Under light load condition, like below 100mA, larger inductance is recommended for improved efficiency. The inductance and its peak current could be calculated by:

$$L = \frac{V_{OUT}}{f_s \times \Delta I_L} \cdot \left(1 - \frac{V_{OUT}}{V_{IN}}\right)$$

$$I_{LP} = I_{LOAD} + \frac{\Delta I_L}{2} = I_{LOAD} + \frac{V_{OUT}}{2 \times f_s \times L} \cdot \left(1 - \frac{V_{OUT}}{V_{IN}}\right)$$

Which f_s is the switching frequency; I_{LOAD} is the load current.

Table2-Inductor Selection Guide

Model	ISAT (A)	DCR (mΩ)	Manufacture
PCM104T-100MS	8.5	27 (typ.)	CYNTEC

Selecting the Diode

The diode connected between SW and GND is the path for the inductor current during the high-side MOSFET turns off. Choose the diode with minimum forward voltage drop and recovery time, like Schottky. And, the reverse voltage rating is greater than maximum input voltage and whose current rating is greater than the maximum load current.

Table3-Diode Selection Guide

Diode	Voltage/Current Rating	Manufacture
B540C	40V, 5A	Diodes Inc.

Selecting the Input capacitor

The input current to the step-down converter is discontinuous, therefore a capacitor is required to supply the AC current for step-down converter to maintain the DC input voltage. Use low ESR capacitor for the best performance. The high frequency impedance of the capacitor should be lower than the input source impedance for bypassing the high frequency switching current locally. Ceramic capacitors with X5R or X7R dielectrics are highly recommended because of their low ESR and small temperature coefficients. To prevent excessive voltage ripple at input, the relationship between the input ripple and the capacitance could be estimated by:

$$\Delta V_{IN} = \frac{I_{LOAD}}{f_s \times C_{IN}} \times \frac{V_{OUT}}{V_{IN}} \times \left(1 - \frac{V_{OUT}}{V_{IN}}\right)$$

For 3A output applications, four 4.7uF ceramic capacitors are sufficient. For $V_{IN} < 6V$ application, the recommended C_{IN} would be $22\mu F \times 4$.

Selecting the Output capacitor

The output capacitor (C_O) is required to maintain the DC output voltage, keeps the output ripple small, and ensures regulation loop stability. The lower ESR capacitors are preferred to keep lower output ripple. The output voltage ripple can be estimated by:

$$\Delta V_{OUT} = \frac{V_{OUT}}{f_s \times L} \times \left(1 - \frac{V_{OUT}}{V_{IN}}\right) \times \left(R_{ESR} + \frac{1}{8 \times f_s \times C_O}\right)$$

Which L is the inductance and R_{ESR} is the equivalent series resistance (ESR) of the output capacitor.

In case of lower ESR capacitor adopted, the output ripple is mainly caused by the capacitance and the output voltage ripple can be estimated by:

$$\Delta V_{OUT} = \frac{V_{OUT}}{8 \times f_s^2 \times L \times C_O} \times \left(1 - \frac{V_{OUT}}{V_{IN}} \right)$$

Or, the ESR dominates the impedance at switching frequency. After simplification, the output voltage ripple can approximated to

$$\Delta V_{OUT} = \frac{V_{OUT}}{f_s \times L} \times \left(1 - \frac{V_{OUT}}{V_{IN}} \right) \times R_{ESR}$$

The characteristics of the output capacitor also affect the loop stability of regulation system. Low ESR ceramic capacitors with X5R or X7R dielectrics are recommended.

Compensation Components

The EML3193 employs current mode control for easy compensation and fast transient response. The system stability and transient response are controlled through the COMP pin. COMP pin is the output of the internal error amplifier. A series capacitor-resistor combination sets a pole-zero combination to control the characteristics of the control system. The DC gain of the voltage feedback loop is given by:

$$A_{VDC} = R_L \cdot G_{CS} \cdot A_{EA} \cdot \frac{V_{FB}}{V_O}$$

Where R_L is the load resistor value, G_{CS} is the current sensing transconductance and A_{EA} is the error amplifier gain. The system has two important poles. One is due to the compensation capacitor (C_{CMP}) and the output resistor (r_O) of error amplifier, and the other is due to the output capacitor (C_O) and the load resistor (R_L). These poles are located at:

$$f_{p1} = \frac{1}{2\pi \cdot C_{CMP} \cdot r_O} = \frac{G_{EA}}{2\pi \cdot C_{CMP} \cdot A_{VEA}}$$

$$f_{p2} = \frac{1}{2\pi \cdot C_O \cdot R_L}$$

Where, G_{EA} is the error amplifier transconductance.

The system has one important zero, due to the compensation capacitor (C_{CMP}) and the compensation resistor (R_{CMP}). The zero is located at:

$$f_{z1} = \frac{1}{2\pi \cdot C_{CMP} \cdot R_{CMP}}$$

The system may have another important zero, if the output capacitor has a large capacitance with a high ESR value. The zero, due to the ESR and a capacitance

of the output capacitor, is located at:

$$f_{ESR} = \frac{1}{2\pi \cdot C_O \cdot R_{ESR}}$$

In this case, a third pole set by the compensation capacitor (C_C) which is directly connected to COMP Pin between GND and the compensation resistor (R_{CMP}) is used to compensate the effect of the ESR zero (f_{ESR}) on the loop gain. This pole is located at:

$$f_{p3} = \frac{1}{2\pi \cdot C_C \cdot R_{CMP}}$$

To shape the converter transfer function for getting an adequate loop gain is the purpose of compensation design. The system open loop unity gain crossover frequency is important.

Lower crossover frequencies result in slower line and load transient responses, while higher crossover frequencies could system unstable. A good compromise is to set the crossover frequency to below one-tenth of the switching frequency. To optimize the compensation components, the following procedure can be used:

1. Choose the compensation resistor (R_{CMP}) to set the desired crossover frequency. Determine the R_{CMP} value by the following equation:

$$R_{CMP} = \frac{2\pi \cdot C_O \cdot f_C \cdot V_O}{G_{EA} \cdot G_{CS} \cdot V_{FB}}$$

Where, f_C is the desired crossover frequency.

2. Choose the compensation capacitor (C_{CMP}) to get the desired phase margin. For applications with typical inductor values, setting the compensation zero, f_{z1} , to below one-fourth of the crossover frequency provides sufficient phase margin. Determine the C_{CMP} value by the following equation:

$$C_{CMP} > \frac{4}{2\pi \cdot R_{CMP} \cdot f_C}$$

Where, R_{CMP} is the compensation resistor value.

To avoid the output voltage unstable due to the parasitic capacitor between the COMP pin and GND, the $C_{CMP} > 100\text{pF}$ is strongly recommended.

3. Determine if the second compensation capacitor (C_c) is required. It is required if the ESR zero of the output capacitor is located at less than half of the switching frequency, the following relationship is valid:

$$\frac{1}{2\pi \cdot C_o \cdot R_{ESR}} < \frac{f_s}{2}$$

If this is the case, then add the second compensation capacitor C_c to set the pole f_{p3} at the location of the ESR zero. Determine the C_c value in the following equation:

$$C_c > \frac{C_o \cdot R_{ESR}}{R_{CMP}}$$

And, a 3~5pF capacitance is suggested to improve full range operating.

Table4-Components Selection Guide

Vout (V)	L (uH)	C _o (uF)	R _{CMP} (kΩ)	C _{CMP} (pF)	C _c (pF)
1.8	4.7	47	36	470	3~5
2.5	4.7~6.8	20	27	470	3~5
3.3	6.8~10	20	33	470	3~5
5.0	15~22	20	50	330	3~5
12	22~33	20	91	220	3~5

4. The estimation is based on 15% of I_{out} current for this table. User can calculate it depend on peak-to-peak ripple current real requirement.

External Bootstrap Diode

An external bootstrap diode is recommended to add between external 5V and BS pin to enhance efficiency of the regulator. The external 5V can be a 5V fixed input from system or a 5V output of the EML3193. The low cost diode, like 1N4148, is sufficient. With such diode, 5V input voltage can output 3.3V and 2.5V with just 30mA load.

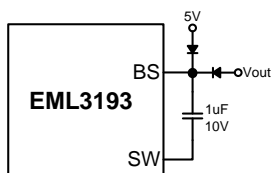

Applications

Typical schematic for PCB layout

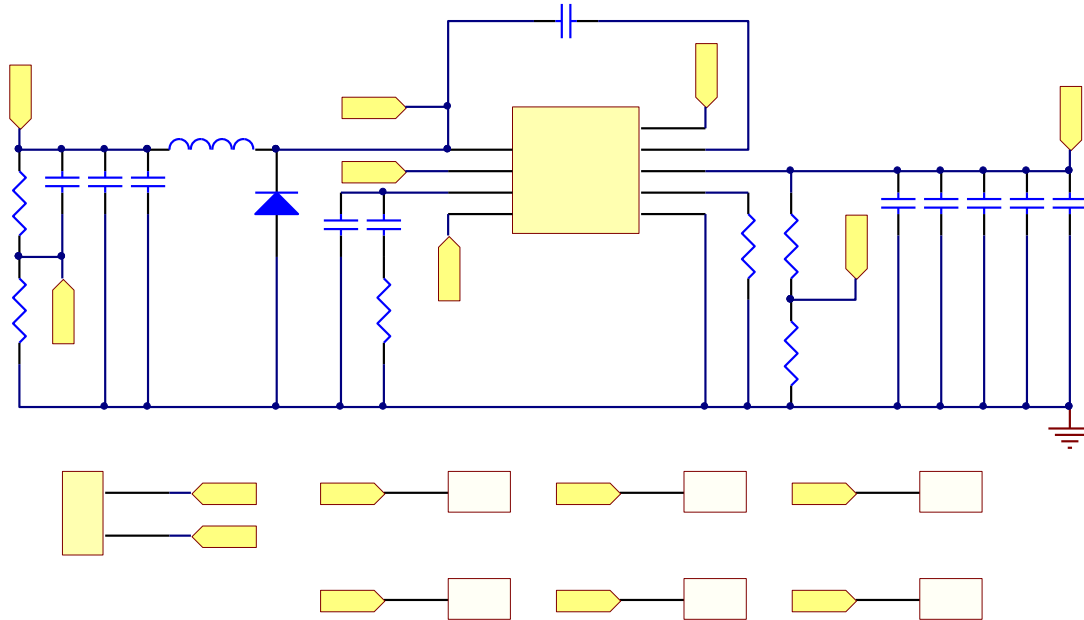

Typical schematic for PCB layout (cont.)

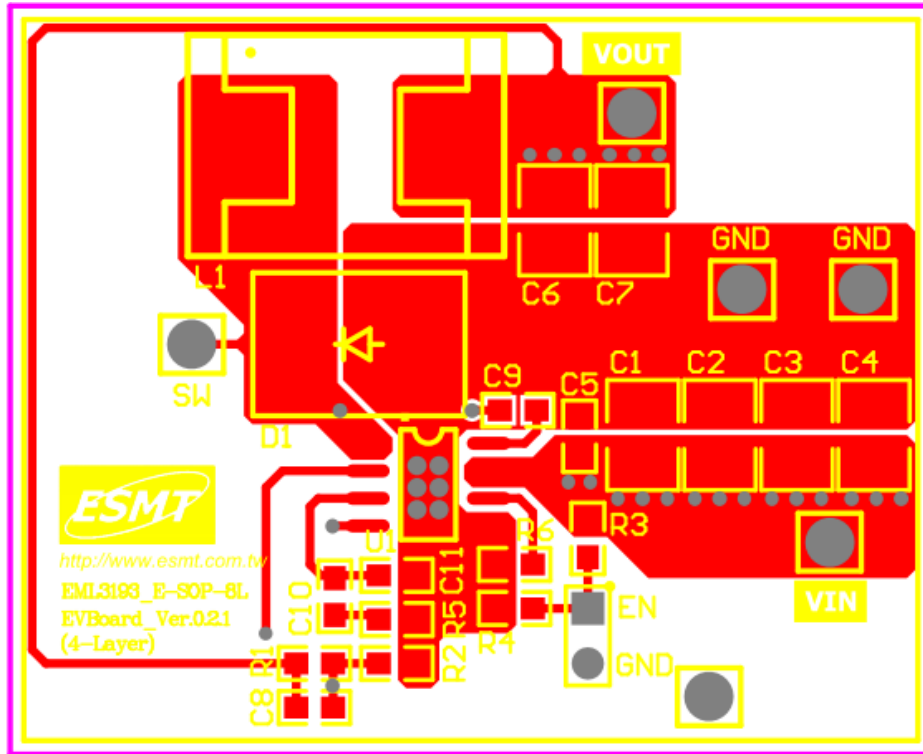

Top-Side Layout

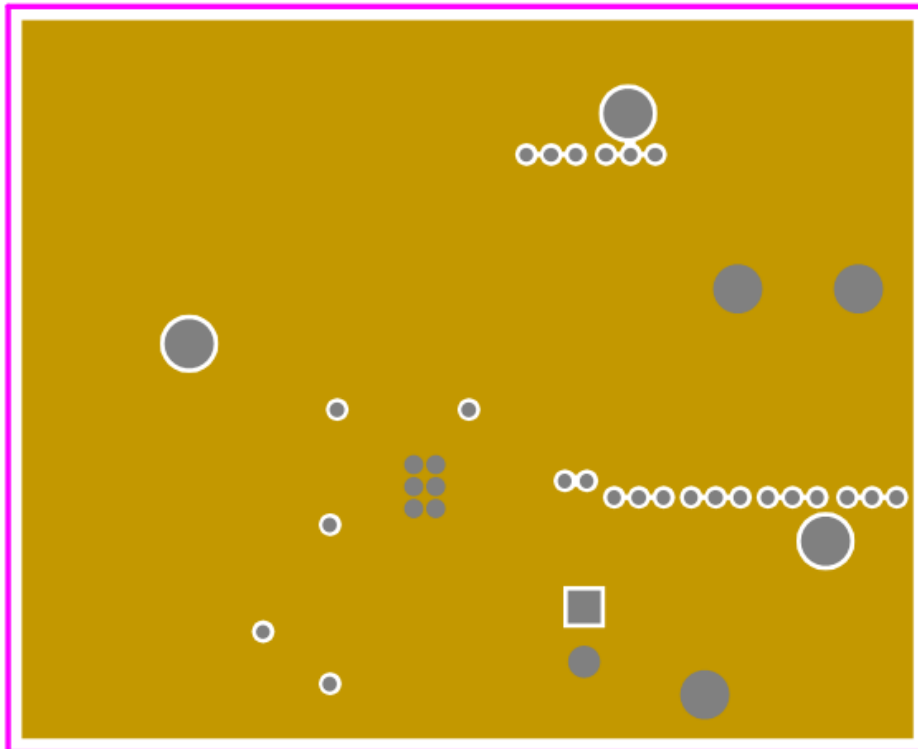

Layer 2 Layout

Typical schematic for PCB layout (cont.)

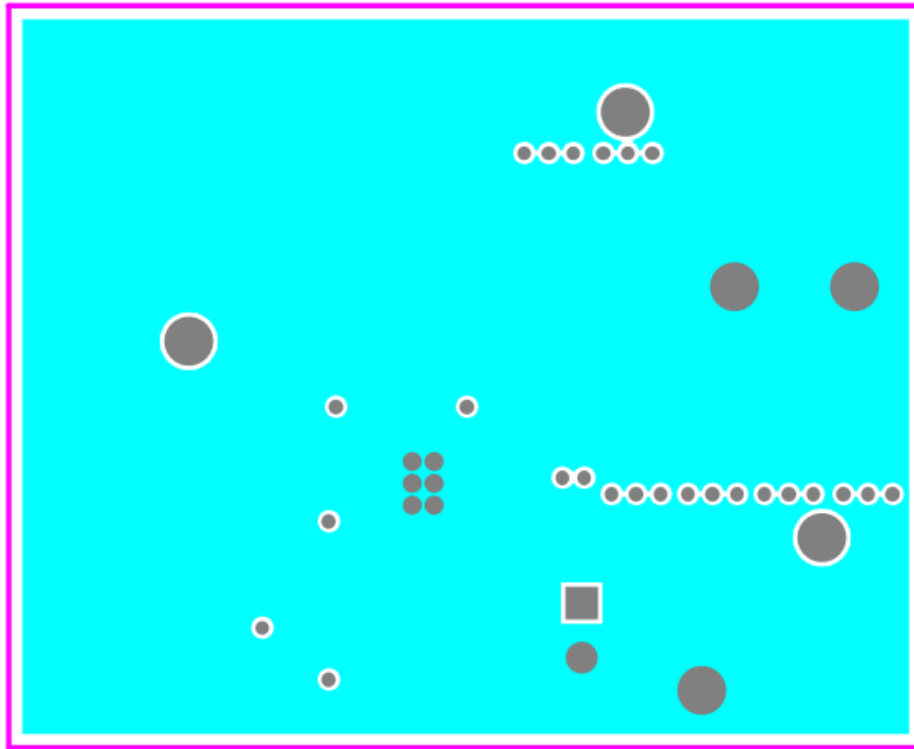

Layer 3 Layout

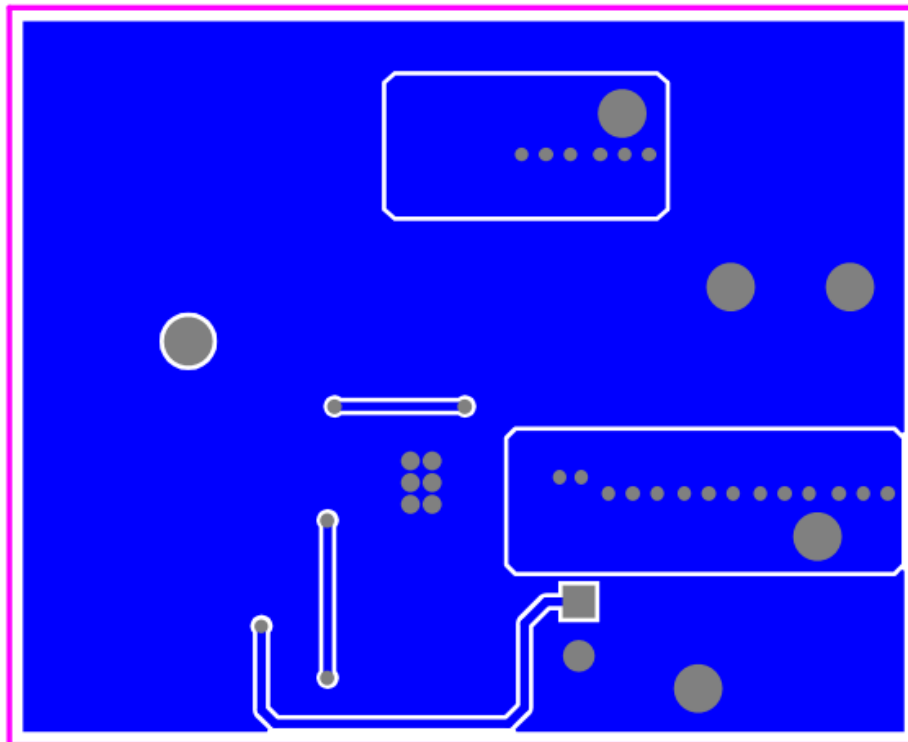

Bottom-Side Layout

Package Outline Drawing E-SOP-8L (150 mil)

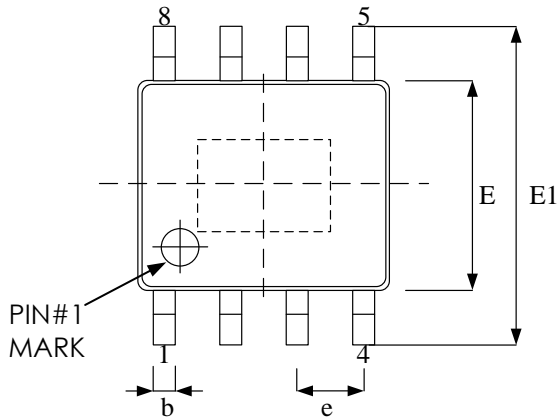

TOP VIEW

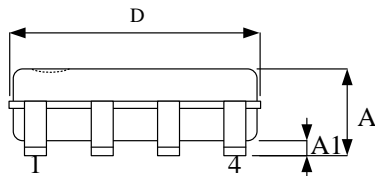

SIDE VIEW

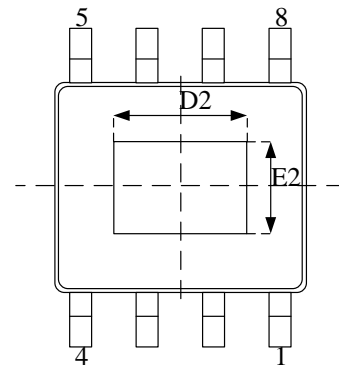

BOTTOM VIEW

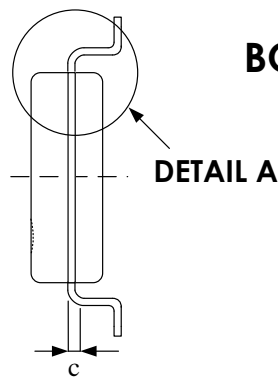

DETAIL A

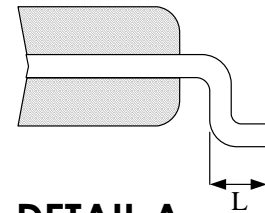

DETAIL A

Symbol	Dimension in mm	
	Min	Max
A	1.35	1.75
A1	0.00	0.25
b	0.31	0.51
c	0.10	0.25
D	4.80	5.00
E	3.81	4.00
E1	5.79	6.20
e	1.27 BSC	
L	0.40	1.27

Exposed pad

	Dimension in mm	
	Min	Max
D2	2.84	3.30
E2	2.06	2.41

Revision History

Revision	Date	Description
0.1	2015.12.03	Initial version.
1.0	2015.12.28	1. Remove preliminary word and modify version to 1.0 2. Modify UVLO Max. spec. form 4.4 to 4.5V
1.1	2016.02.05	1. Updated the current limit. 2. Updated the VIN UVLO Threshold. 3. Modified the Absolute Maximum Ratings.
1.2	2016.04.18	1. Updated the typical application circuit. 2. Updated the functional block diagram. 3. Updated the detailed description of UVLO control. 4. Updated the PCB schematic.
1.3	2016.05.13	Updated Package Outline Drawing
1.4	2016.06.06	Added the Recommended Operating Conditions.
1.5	2016.07.11	1. Modified the thermal parameter 2. Modified the switching frequency formula.
1.6	2016.10.07	1. Updated the typical application circuit. 2. Update the EN threshold spec. in electrical characteristics. 3. Updated the detailed description of UVLO control. 4. Updated the typical schematic for PCB layout.
1.7	2017.02.17	1. Modify marking information. 2. Updated the quiescent current information in electrical characteristics.

Important Notice

All rights reserved.

No part of this document may be reproduced or duplicated in any form or by any means without the prior permission of ESMT.

The contents contained in this document are believed to be accurate at the time of publication. ESMT assumes no responsibility for any error in this document, and reserves the right to change the products or specification in this document without notice.

The information contained herein is presented only as a guide or examples for the application of our products. No responsibility is assumed by ESMT for any infringement of patents, copyrights, or other intellectual property rights of third parties which may result from its use. No license, either express, implied or otherwise, is granted under any patents, copyrights or other intellectual property rights of ESMT or others.

Any semiconductor devices may have inherently a certain rate of failure. To minimize risks associated with customer's application, adequate design and operating safeguards against injury, damage, or loss from such failure, should be provided by the customer when making application designs.

ESMT's products are not authorized for use in critical applications such as, but not limited to, life support devices or system, where failure or abnormal operation may directly affect human lives or cause physical injury or property damage. If products described here are to be used for such kinds of application, purchaser must do its own quality assurance testing appropriate to such applications.