

50mA Ultra-Low Quiescent Current LDO Linear Regulator

General Description

The EMP8046 is a positive voltage regulator with high accuracy output voltage and ultra-low quiescent current which is typically 1.0 μ A. The device is ideal for battery powered handheld equipments which require low quiescent current.

The EMP8046 contains a bandgap voltage reference, an error amplifier, a P-channel pass transistor, and a resistor-divider for setting output voltage. The output voltage is fixed with high accuracy by advanced trimming technology.

The EMP8046 has been designed to be used with low cost ceramic capacitors and requires a minimum output capacitor of 1.0 μ F. The devices are available in SOT-23-3 and SOT-89-3 packages.

Applications

- Battery power equipments
- Portable communication devices
- Precision voltage references
- Hand-Held electronics
- Wireless communication systems

Features

- Operating voltages range: 2.5V to 18V
- Maximum output current: 100mA
- Low dropout: 800mV @ 50mA
- $\pm 2\%$ output voltage tolerance
- Low ESR capacitor compatible
- RoHS compliant and 100% Lead(Pb)-free and green (halogen free with commercial standard)

Typical Application

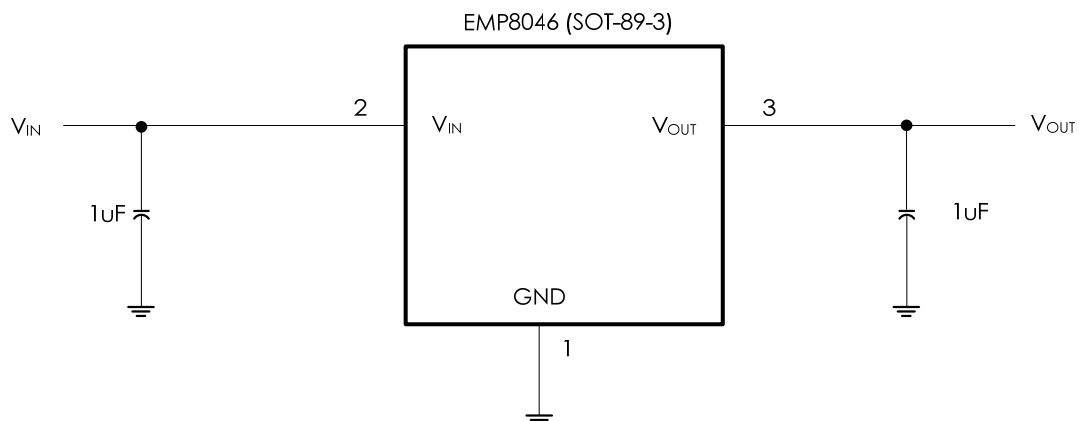

Connection Diagrams

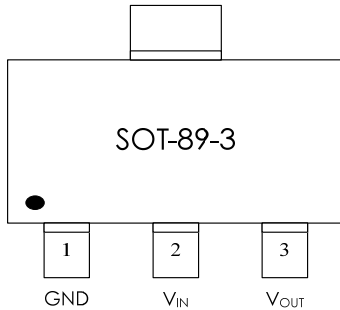
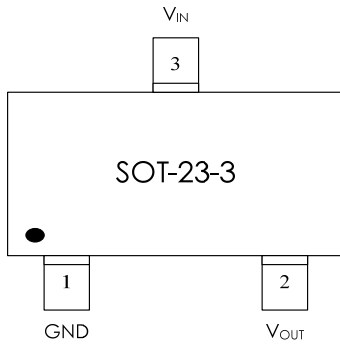

Order information

EMP8046-XXVB03NRR
 XX Output voltage
 VB03 SOT-23-3 Package
 NRR RoHS & Halogen free package
 Rating: -40 to 85°C
 Package in Tape & Reel

EMP8046-XXVG03NRR
 XX Output voltage
 VG03 SOT-89-3 Package
 NRR RoHS & Halogen free package
 Rating: -40 to 85°C
 Package in Tape & Reel

Order, Marking and Packing Information

Package	Vout	Product ID.	Marking	Packing
SOT-23-3	3.3V	EMP8046-33VB03NRR		Tape & Reel 3Kpcs
	5.0V	EMP8046-50VB03NRR		
SOT-89-3	3.3V	EMP8046-33VG03NRR		Tape & Reel 1Kpcs
	5.0V	EMP8046-50VG03NRR		

Pin Functions

Name	SOT-23-3	SOT-89-3	Function
GND	1	1	Ground Pin
V _{OUT}	2	3	Output Voltage
V _{IN}	3	2	Supply Voltage Input Require a minimum input capacitor around 1μF to ensure stability and sufficient decoupling from the ground pin.

Functional Block Diagram

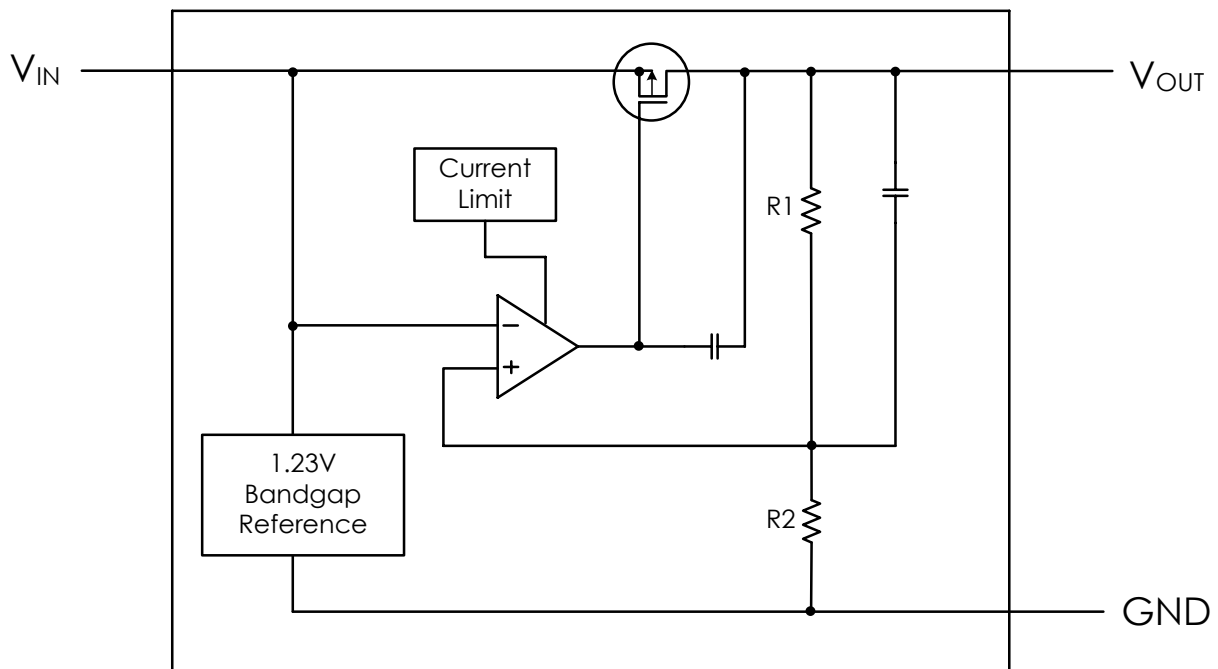

FIG.1. Functional Block Diagram of EMP8046

Absolute Maximum Ratings (Notes 1, 2)

V_{IN}	-0.3V to 20V	Junction Temperature (T_J)	150°C
Power Dissipation	(Note 3)	Lead Temperature (Soldering, 10 sec.)	260°C
Storage Temperature Range	-65°C to 150°C		

Operating Ratings (Note 1, 2)

Supply Voltage	2.5V to 18V		101°C/W (SOT-89-3)
Operating Temperature Range	-40°C to 85°C	Thermal Resistance (θ_{JC} , Note 4)	82°C/W (SOT-23-3)
Thermal Resistance (θ_{JA} , Note 3)	156°C/W (SOT-23-3)		54°C/W (SOT-89-3)

Electrical Characteristics

$T_A = 25^\circ\text{C}$, $V_{OUT}(\text{NOM})=5\text{V}$; unless otherwise specified, all limits guaranteed for $V_{IN} = V_{OUT} + 1\text{V}$, $C_{IN} = C_{OUT} = 1\mu\text{F}$.

Symbol	Parameter	Conditions	Min	Typ (Note 6)	Max	Units
V_{IN}	Input Voltage		2.5		18	V
ΔV_{OUT}	Output Voltage	$V_{IN}=V_{OUT}+1.0\text{V}$, $I_{OUT}=1\text{mA}$, $V_{OUT} \leq 2.6\text{V}$	V_{OUT}^* 0.976	V_{OUT}	V_{OUT}^* 1.024	V
		$V_{IN}=V_{OUT}+1.0\text{V}$, $I_{OUT}=1\text{mA}$, $V_{OUT} \geq 2.7\text{V}$	V_{OUT}^* 0.98		V_{OUT}^* 1.02	
I_{OUT}	Maximum Output Current	Average DC Current Rating	50			mA
I_{LIMIT}	Output Current Limit				100	mA
I_Q	Supply Current	$I_{OUT} = 0\text{mA}$		1.0	2.5	μA
		$I_{OUT} = 50\text{mA}$		1.0	2.5	
V_{DO}	Dropout Voltage $V_{OUT}=5.0\text{V}$ (Note. 7)	$I_{OUT} = 1\text{mA}$		16	20	mV
		$I_{OUT} = 10\text{mA}$		160	200	
		$I_{OUT} = 50\text{mA}$		800	1000	
ΔV_{OUT}	Line Regulation	$I_{OUT} = 1\text{mA}$, $(V_{OUT} + 1\text{V}) \leq V_{IN} \leq 12\text{V}$		0.2	0.3	%/V
	Load Regulation	$0.1\text{mA} \leq I_{OUT} \leq 50\text{mA}$		0.01	0.02	%/mA

Note 1: Absolute maximum ratings indicate limits beyond which damage may occur.

Note 2: All voltages are in respect to the potential of the ground pin.

Note 3: θ_{JA} is measured in the natural convection at $T_A=25^\circ\text{C}$ on a high effectively thermal conductivity test board (2 layers, 2SOP).

Note 4: θ_{JC} represents the resistance between the chip and the top of the package case.

Note 5: Maximum power dissipation for the device is calculated using the following equation:

$$P_D = \frac{T_{J(\text{MAX})} - T_A}{\theta_{JA}}$$

Where $T_{J(\text{MAX})}$ is the maximum junction temperature, T_A is the ambient temperature, and θ_{JA} is the junction-to-ambient thermal resistance. For example, for the SOT-89-3 package $\theta_{JA}=101^\circ\text{C}/\text{W}$, $T_{J(\text{MAX})}=150^\circ\text{C}$ and using $T_A=25^\circ\text{C}$, the maximum power dissipation is 1.23W.

The derating factor $(-1/\theta_{JA})=-9.9\text{mW}/^\circ\text{C}$. Below 25°C the power dissipation figure can be increased by 9.9mW per degree and similarly decreased by this factor for temperatures above 25°C .

Note 6: Typical values represent the most typical parametric norm.

Note 7: Dropout voltage is measured by reducing V_{IN} until V_{OUT} drops to 98% of its nominal value.

Typical Performance Characteristics

Unless otherwise specified, $V_{IN} = V_{OUT(NOM)} + 1V$, $V_{OUT}=5V$, $C_{IN} = C_{OUT} = 1.0\mu F$, $T_A = 25^\circ C$

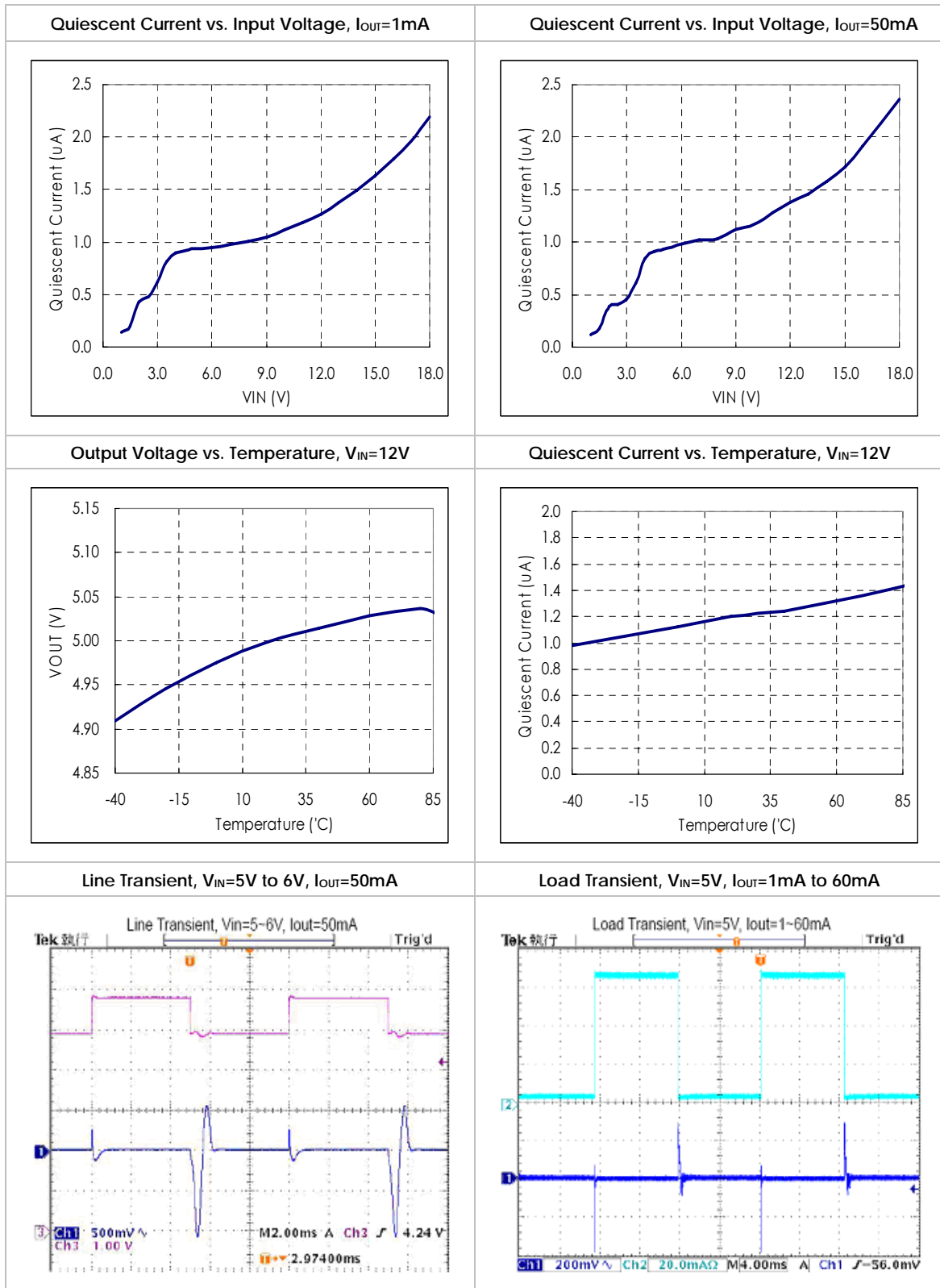

Application Information

General Description

The EMP8046 is a low quiescent current LDO linear regulator. It supplies a preset 5.0V output voltage for output current up to 50mA. Other mask options for special output voltages from 1.5V to 5.0V with 100mV increment are also available. As illustrated in function block diagram, EMP8046 consists of a 1.23V band gap reference, error amplifier, P-channel pass transistor and an internal feedback voltage divider.

The 1.23V band gap reference is connected to the error amplifier, which compares the band gap reference to the feedback voltage. Afterwards, the error amplifier amplifies the voltage difference. If the feedback voltage is lower than the reference voltage, the pass-transistor gate is pulled lower. This allows more current to pass to the output pin and increases the output voltage. If the feedback voltage is too high, the pass-transistor gate is pulled up to decrease the output voltage.

The output voltage is feedback through an internal resistor-divider connected to OUT. Additional blocks include an output current limiter, thermal sensor, and shutdown logic.

Internal P-channel Pass Transistor

The EMP8046 features a P-channel MOSFET pass transistor. Unlike similar designs using PNP pass transistors, P-channel MOSFETs require no base drive, which reduces ground pin current. PNP- based regulators also waste considerable current in dropout conditions when the pass transistor saturates, and use high base-drive currents under large loads. The EMP8046 does not experience these drawbacks and consumes only 1.0µA (Typ.) of ground pin current under heavy loads as well as in dropout conditions.

Input-Output Voltage

A regulator's minimum input-output voltage differential, or dropout voltage, determines the lowest usable supply voltage. In battery-powered systems, this will determine the useful end-of-life battery voltage. The EMP8046 uses a P-channel MOSFET pass transistor, whose dropout voltage is a function of drain-to-source on-resistance ($R_{DS(ON)}$) multiplied by the load current.

$$V_{DROPOUT} = V_{IN} - V_{OUT} = R_{DS(ON)} \times I_{OUT}$$

Input Capacitor

A minimum input capacitance of 1µF is required for EMP8046. The capacitor value may be increased without limit. Improper workbench set-ups may have adverse effects on the normal operation of the regulator. One example is the instability that may result from long supply lead inductance coupling to the output through the gate capacitance of the pass transistor. This will establish a pseudo LCR network and is likely to happen under high current conditions or near dropout. A 10µF tantalum input capacitor will dampen the parasitic LCR action due to its high ESR. However, cautions should be exercised to avoid regulator short-circuit damage when tantalum capacitors are used since they are prone to fail in short-circuit operating conditions.

Output Capacitor

The EMP8046 is specially designed for use with ceramic output capacitors of as low as 1.0 μ F to take advantage of the savings in cost and space as well as the superior filtering of high frequency noise. Capacitors of higher value or other types may be used, but it is important to make sure its equivalent series resistance (ESR) is restricted to less than 0.5 Ω . The use of larger capacitors with smaller ESR values is desirable for applications involving large and fast input or output transients, as well as for situations where the application systems are not physically located immediately adjacent to the battery power source. Typical ceramic capacitors suitable for use with the EMP8046 are X5R and X7R. The X5R and the X7R capacitors are able to maintain their capacitance values to within $\pm 20\%$ and $\pm 10\%$, respectively, as the temperature increases.

Power Dissipation

An IC junction with a low thermal resistance is preferred because it is relatively effective in dissipating its thermal energy to its ambient, thus resulting in a relatively low and desirable junction temperature. The relationship between θ_{JA} and T_J is as follows:

$$T_J = \theta_{JA} \times (P_D) + T_A$$

T_A is the ambient temperature, and P_D is the power generated by the IC and can be written as:

$$P_D = I_{OUT} (V_{IN} - V_{OUT})$$

As the equations show, it is desirable to work with ICs whose θ_{JA} values are small so that T_J does not increase strongly with P_D . To avoid thermally overloading the EMP8046, refrain from exceeding the absolute maximum junction temperature rating of 150°C under continuous operating conditions. Overstressing the regulator with high loading currents and elevated input-to-output differential voltages can increase the IC die temperature significantly.

Package Outline Drawing
SOT-23-3

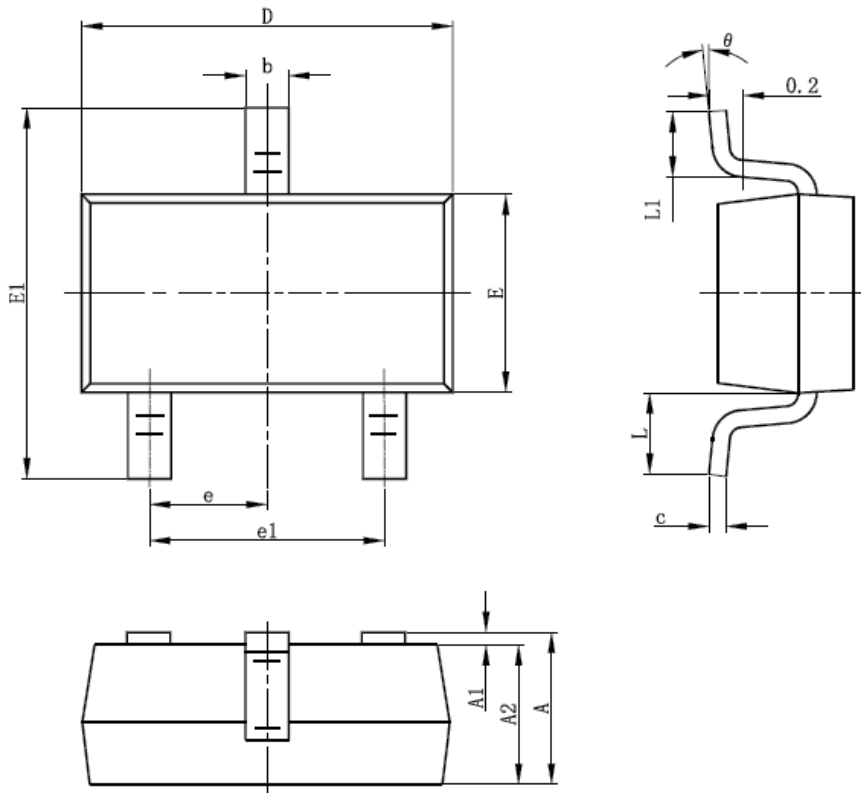

Symbol	Dimensions In Millimeters		Dimensions In Inches	
	Min	Max	Min	Max
A	1.050	1.250	0.041	0.049
A1	0.000	0.100	0.000	0.004
A2	1.050	1.150	0.041	0.045
b	0.300	0.400	0.012	0.016
c	0.100	0.200	0.004	0.008
D	2.820	3.020	0.111	0.119
E	1.500	1.700	0.059	0.067
E1	2.650	2.950	0.104	0.116
e	0.950TYP		0.037TYP	
e1	1.800	2.000	0.071	0.079
L	0.700REF		0.028REF	
L1	0.300	0.600	0.012	0.024
θ	0°	8°	0°	8°

Package Outline Drawing
SOT-89-3

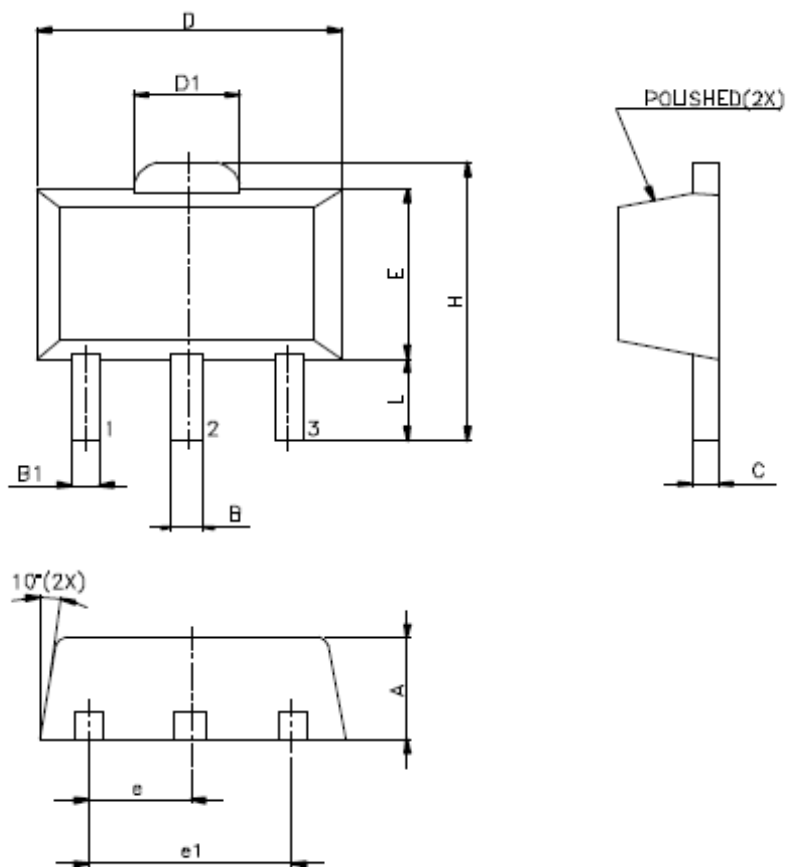

SYMBPLS	MIN.	NOM.	MAX.
A	1.40	—	1.60
B	0.44	—	0.56
B1	0.36	—	0.48
C	0.35	—	0.44
D	4.40	—	4.60
D1	1.35	—	1.83
E	2.29	—	2.60
H	3.94	—	4.25
E	1.50 BSC		
e1	3.00 BSC		
L	0.89	—	1.2

UNIT: MM

Revision History

Revision	Date	Description
0.1	2010.09.12	Original
0.2	2011.12.02	Modify the output voltage range.

Important Notice

All rights reserved.

No part of this document may be reproduced or duplicated in any form or by any means without the prior permission of ESMT.

The contents contained in this document are believed to be accurate at the time of publication. ESMT assumes no responsibility for any error in this document, and reserves the right to change the products or specification in this document without notice.

The information contained herein is presented only as a guide or examples for the application of our products. No responsibility is assumed by ESMT for any infringement of patents, copyrights, or other intellectual property rights of third parties which may result from its use. No license, either express, implied or otherwise, is granted under any patents, copyrights or other intellectual property rights of ESMT or others.

Any semiconductor devices may have inherently a certain rate of failure. To minimize risks associated with customer's application, adequate design and operating safeguards against injury, damage, or loss from such failure, should be provided by the customer when making application designs.

ESMT's products are not authorized for use in critical applications such as, but not limited to, life support devices or system, where failure or abnormal operation may directly affect human lives or cause physical injury or property damage. If products described here are to be used for such kinds of application, purchaser must do its own quality assurance testing appropriate to such applications.