

---

# **EMPCD081A**

**8-Digit Calculator With  
Tax / Euro Function  
(Battery / Solar / Dual  
Power Type)**

## **Product Specification**

**DOC. VERSION 0.3**

**ELAN MICROELECTRONICS CORP.**

September 2004

---



---

**Trademark Acknowledgments:**

IBM is a registered trademark and PS/2 is a trademark of IBM.

Windows is a trademark of Microsoft Corporation.

ELAN and ELAN logo  are trademarks of ELAN Microelectronics Corporation.

Copyright © 2004 by **ELAN Microelectronics Corporation**

**All Rights Reserved**

Printed in Taiwan

The contents of this specification are subject to change without further notice. ELAN Microelectronics assumes no responsibility concerning the accuracy, adequacy, or completeness of this specification. ELAN Microelectronics makes no commitment to update, or to keep current the information and material contained in this specification. Such information and material may change to conform to each confirmed order.

In no event shall ELAN Microelectronics be made responsible for any claims attributed to errors, omissions, or other inaccuracies in the information or material contained in this specification. ELAN Microelectronics shall not be liable for direct, indirect, special incidental, or consequential damages arising from the use of such information or material.

The software (if any) described in this specification is furnished under a license or nondisclosure agreement, and may be used or copied only in accordance with the terms of such agreement.

ELAN Microelectronics products are not intended for use in life support appliances, devices, or systems. Use of ELAN Microelectronics product in such applications is not supported and is prohibited.

NO PART OF THIS SPECIFICATION MAY BE REPRODUCED OR TRANSMITTED IN ANY FORM OR BY ANY MEANS WITHOUT THE EXPRESSED WRITTEN PERMISSION OF ELAN MICROELECTRONICS.



---

**ELAN MICROELECTRONICS CORPORATION**

---

**Headquarters:**

No. 12, Innovation Road 1  
Hsinchu Science Park  
Hsinchu, Taiwan 30077  
Tel: +886 3 563-9977  
Fax: +886 3 563-9966  
<http://www.emc.com.tw>

**Hong Kong:**

**Elan (HK) Microelectronics Corporation, Ltd.**  
Flat A, 19/F., World Tech Centre  
95 How Ming Street, Kwun Tong  
Kowloon, HONG KONG  
Tel: +852 2723-3376  
Fax: +852 2723-7780  
[elanhk@emc.com.hk](mailto:elanhk@emc.com.hk)

**USA:**

**Elan Information Technology Group (USA)**  
1821 Saratoga Ave., Suite 250  
Saratoga, CA 95070  
USA  
Tel: +1 408 366-8225  
Fax: +1 408 366-8220

**Europe:**

**Elan Microelectronics Corp. (Europe)**  
Siewerdstrasse 105  
8050 Zurich, SWITZERLAND  
Tel: +41 43 299-4060  
Fax: +41 43 299-4079  
<http://www.elan-europe.com>

**Shenzhen:**

**Elan Microelectronics Shenzhen, Ltd.**  
SSMEC Bldg., 3F, Gaoxin S. Ave.  
Shenzhen Hi-Tech Industrial Park  
Shenzhen, Guangdong, CHINA  
Tel: +86 755 2601-0565  
Fax: +86 755 2601-0500

**Shanghai:**

**Elan Microelectronics Shanghai, Ltd.**  
23/Bldg. #115 Lane 572, Bibo Road  
Zhangjiang Hi-Tech Park  
Shanghai, CHINA  
Tel: +86 21 5080-3866  
Fax: +86 21 5080-4600

---

# Contents

<b>1</b>	<b>General Description</b> .....	<b>1</b>
<b>2</b>	<b>Features</b> .....	<b>1</b>
<b>3</b>	<b>Pin Descriptions</b> .....	<b>2</b>
<b>4</b>	<b>Function Descriptions</b> .....	<b>2</b>
	A) Operation Characteristics .....	2
	B) Keyboard Description .....	4
	C) Error Conditions .....	7
	D) Lcd Display .....	8
	E) Waveforms For Display .....	9
<b>5</b>	<b>Absolute Maximum Ratings</b> .....	<b>10</b>
<b>6</b>	<b>Electrical Characteristics</b> .....	<b>10</b>
<b>7</b>	<b>Application Circuit</b> .....	<b>12</b>
<b>8</b>	<b>Pad Diagram</b> .....	<b>13</b>



### Specification Revision History

Doc. Version	Revision Description	Date
0.1	Initial version	2004/05/04
0.2	a. Modify PIN DESCRIPTIONS in page4. b. Delete K11 and K12 in page6. c. Modify LCD display S1A9 and S2B9 in page11.	2004/05/10
0.3	a. <a href="#">Modify DC spec. of IDDOP as page14.</a>	<a href="#">2004/09/15</a>



## 1 General Description

The EMPCD081A is a single-chip LS1 CMOS calculator for 8-digit 1 memory. Besides, the EMPCD081A is an arithmetic four standard types of general function (+, -, ×, ÷), TAX / EURO function, percentage calculation functions, leading zero and trailing zero suppression, chain calculations, MU calculation, Auto Power OFF available. Dual power supply operation, wide operating voltage, and lower power consumption make it suitable for 1.5 solar battery operated calculator.

## 2 Features

- Display : 8-digit of data, 1-digits of sign, error, memory load symbol.
- TAX / EURO function available.
- Algebraic mode.
- Standard 4 function (addition, subtraction, multiplication, division).
- Memory calculation.
- Automatic percentage operation with add-on discount.
- Constant calculation.
- Chain calculation.
- Change sign.
- Trailing zero suppression.
- Punction on display, commas for thousands.
- Memory contents indicator, turned on with nonzero in the memory.
- Result overflow, indicating during calculation (most function key are locked as it happened).
- Memory overflow indicating.
- Complementary output buffer for direct driving of liquid crystal display.
- Oscillator/clock generator internal to chip.
- Keyboard encoding internal to chip.
- Automatic power on clear.
- Wide supply voltage range (1.2 to 1.8V)
- Very low power consumption.
- Floating minus.
- Two key roll over available.



### 3 Pin Descriptions

Symbol	I/O	Function
COM1~3	O	LCD Common signal output.
A1 ~ A3	O	LCD Segment signal output and strobe output for switch status.
A4 ~ A13	O	LCD Segment signal output.
B1 ~ B3	O	LCD Segment signal output and strobe output for switch status.
B4 ~ B13	O	LCD Segment signal output.
C1 ~ C2	O	LCD Segment signal output and strobe output for switch status.
C3 ~ C13	O	LCD Segment signal output.
VDD,VSS	---	Positive and negative power supply pin.
VA,VB	---	Voltage doubler for LCD, connects a capacitor (0.1uF) between both pins.
VEE	---	LCD voltage from voltage doubler, connects a capacitor (0.1uF) to pin VDD.
TS1	I	Test pin input, be opened.
RESET	I	System reset / AC key input. (built-in schmitt trigger for debouncing)
K0 ~ K2	O	Keyboard polling signal output pins.
K3 ~ K7	I/O	Keyboard polling signal output and strobe input pins.
K8 ~ K10	I	Keyboard strobe input pins.
K11~K14	I	Switch status strobe input pins.

### 4 Function Descriptions

#### A) Operation Characteristics

##### CONSTANT OPERATION

The EM34011 has implied constant mode on +, -, X, ÷ and % operations. The constant is performed automatically by the "=" key, "% " key, or "% " key without a constant for addition, subtraction and division while the first operand is the constant for multiplication.

##### NUMBER ENTRY

Numericals can be entered up to 8-digit.

##### MEMORY PROTECTION

In any error detection, the memory contents present before the error detection are protected.

##### MEMORY INDICATION

If the memory contents are a number other than zero, "M" is indicated in the sign-digit position.

##### AUTO POWER OFF

If no key is depressed for a specific period of time, the power supply will automatically turn off .

**KEY DEFINITION**

■ Touch Key Constitution

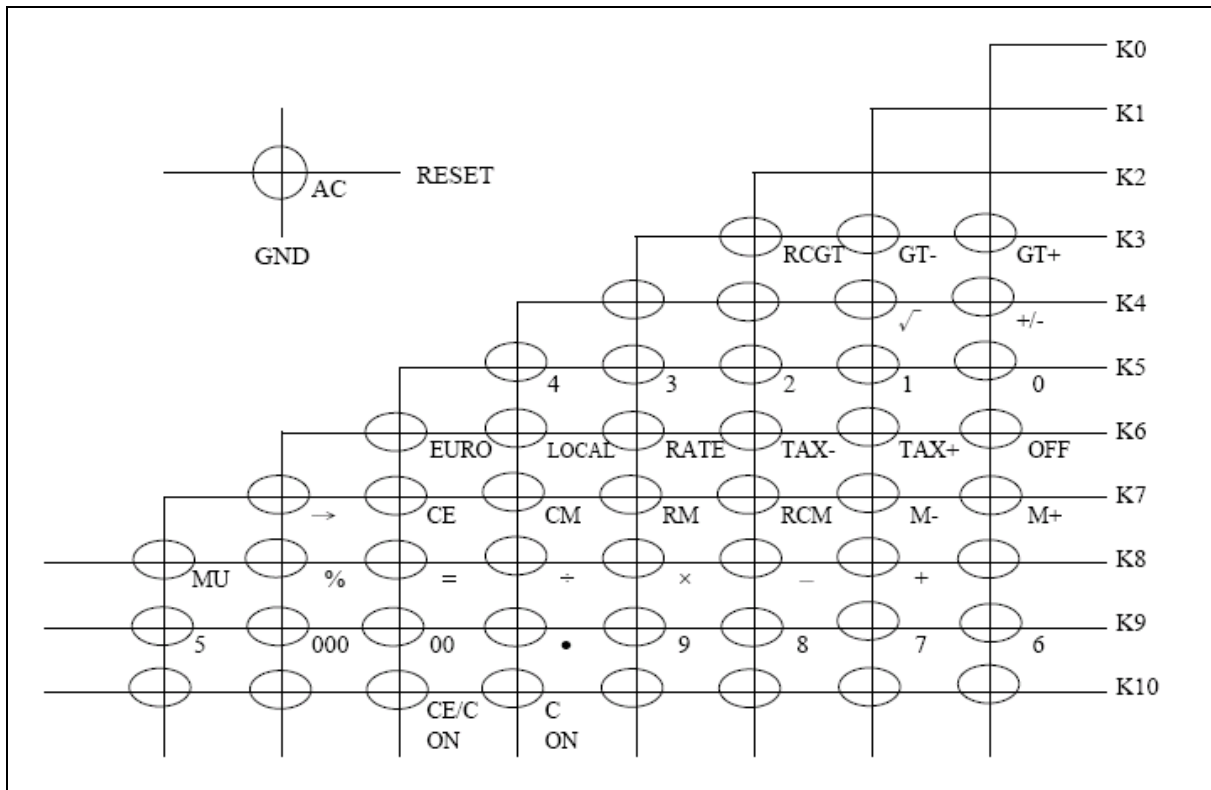

■ Lock Key Constitution

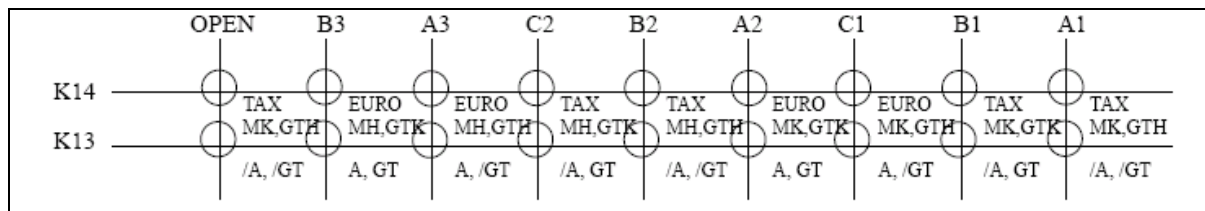

K14 : Select with TAX / EURO function and Memory Hold Status, MH (Memory Hold), MK (Memory Kill), GTH (GT Memory Hold) and GTK (GT Memory Kill) at Auto Power OFF or OFF key.

K13 : Select with Auto Power OFF mode (A) and Grand total function (GT).



## B) Keyboard Description

### EQUAL KEY (=)

- Performs Keyed-in operation and maintains that operation for possible use.
- Establishes power/reciprocation calculation.

### MULTIPLICATION KEY (X)

- Enters multiplicand.
- Performs previous operation and displays result.

### DIVISION KEY ( $\div$ )

- Enters dividend.
- Performs previous operation and displays result.

### ADDITION KEY (+)

- Conditions machine for an addition.
- Performs previous operation and displays result.

### SUBTRACTION KEY (-)

- Conditions machine for a subtraction.
- Performs previous operation and displays result.

### PERCENT KEY (%)

The purpose of the percent key is to allow for calculation of add-on and discount.

Determination of add-on requires the principal amount to be the first entry followed by the "+" or "X" key, with the percentage being the second entry. Depression of the percent key yields the amount to add on, such as tax or interest. Depression of the "=" key adds this amount to the principal.

### CHANGE SIGN KEY (+/-)

Pushing the "+/-" key twice in succession causes the corresponding sign to appear and disappear. During digit entry, this function changes the sign of the entered factor.





#### **POWER ON/ALL CLEAR KEY (ON/AC)**

- First push power-on displays "0".
- In the middle of a digit entry, a second push will clear all operating register.

#### **CLEAR ENTRY/CLEAR KEY (CE/C)**

- During the digit entry, the first depression will clear the entry register. And display the previous enter number again.
- The second push will clear all registers.

#### **CLEAR ENTRY KEY (CE)**

During the digit entry will clear the entry register and display number "0".

#### **SQUARE ROOT KEY ( )**

Extracts the square root of a positive number displayed in the entry register.

#### **MEMORY PLUS KEY (M+)**

- Adds the current display to the contents of memory.
- It will terminate a number entry.

#### **MEMORY MINUS KEY (M-)**

- Subtracts the current display from the contents of memory
- It will terminate a number entry.

#### **MEMORY RECALL AND CLEAR KEY (RCM)**

- First push, as RM key, transfers the contents of the memory register into the display register.
- Second push, as CM key, clears the memory.

#### **MARK-UP KEY (MU)**

- Execute add-on calculation by  $A (\times) B$  (MU) or discount calculation by  $A (\times) B (+/-)$  (MU).
- Execute selling price (mark-up) calculation by  $A [/] B$  [MU] or cost (mark-down) calculation by  $A [/] B [+/-]$  [MU].
- When intermediate result of addition and subtraction is displayed, execute changing rate calculation, which is increase rate calculation by  $A [+] B [-]$  [MU] or growing rate calculation by  $A [+] B [+]$  [MU].

**NUMBER, DECIMAL KEY (“00”, “0 – 9”, “.”)**

The first number key in a sequence will clear the display and enter the digit in the display. Successive entries will shift the display left and enters the data in display register. The first decimal point entered is effective. An attempted entry of more than 8 digits or 7 decimal places will be ignored.

**SHIFT KEY (→)**

Delete the rightest digit and others will shift to right.

**TAX+ (TAX+)**

- Execute TAX-including calculation of displayed number, TAX rate is in TAX memory.
- In the halfway of four rules of arithmetic, TAX-including calculation don't break the intermediate result, so TAX-including is used in expression.
- When immediately after [RATE] key, store displayed number in TAX memory.

**TAX- (TAX-)**

- Execute TAX-excluding calculation of displayed number, TAX rate is in TAX memory.
- In the halfway of four rules of arithmetic, TAX-excluding calculation don't break the intermediate result, so TAX-excluding is used in expression.

**ERUO KEY (EURO)**

- The depressing will perform the conversion of "key-in number/rate".  
The result is automatically rounded to 2 decimal.
- After LOCAL key is depressed and make the conversion, the depressing of EURO key will recall the key-in number.

**LOCAL KEY (LOCAL)**

- The depressing will perform the conversion of "key-in number x rate".  
The result is automatically rounded to 2 decimal.
- After EURO key is depressed and make the conversion, the depressing of LOCAL key will recall the key-in number.

**TAX RATE SET KEY (RATE)**

- The depressing will save the entry number as TAX / EURO rate.



## C) Error Conditions

### ERROR DETECTION

System errors occur when :

- The integral part of any calculation result exceeds 8 digits.
- The integral part of any memory calculation result exceeds 8-digit or when the integral part of any addend or subtrahend to memory exceeds 8-digit.
- A division by zero is attempted.

### ERROR INDICATION

System error :

- "0" is indicated in the first-digit position and "E" in the sign-digit position.
- The high-order 8-digit of a calculation result is indicated together with "E". The location of the decimal point corresponds to the result of calculation times  $1e-8$ , and no zero shift is performed.

### ERROR RELEASE

System error :

A system error can be released by depressing ON/AC key or CE/C key. However the calculation result is not cleared by CE/C key but is retained.

## D) Lcd Display

### INTER CONNECTION OF LCD (TAX FUNCTION)

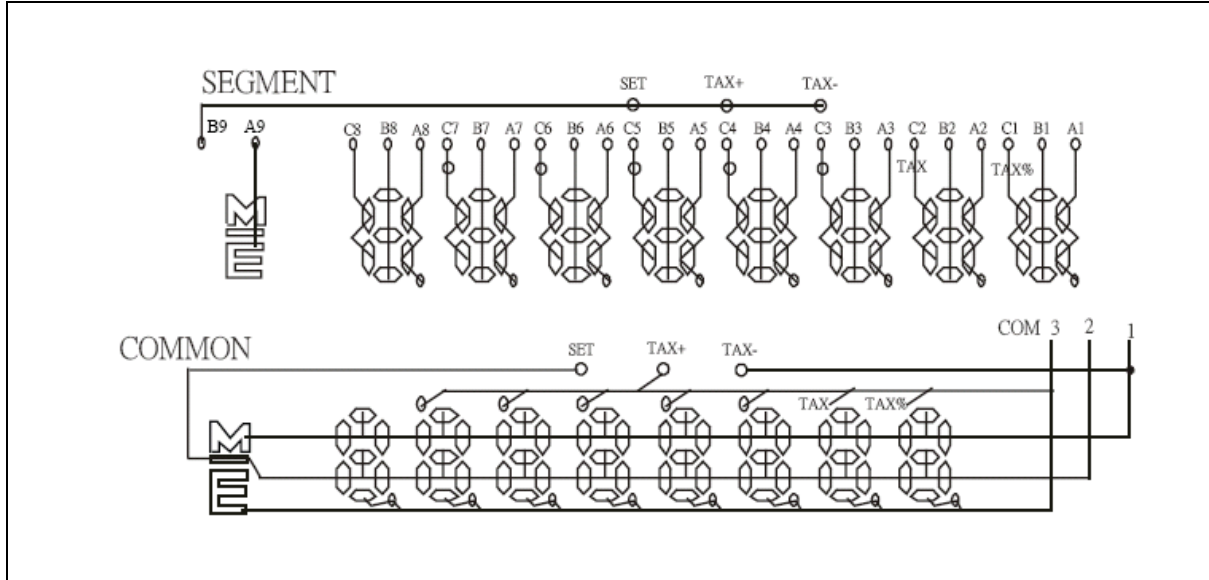

### INTER CONNECTION OF LCD (EURO FUNCTION)

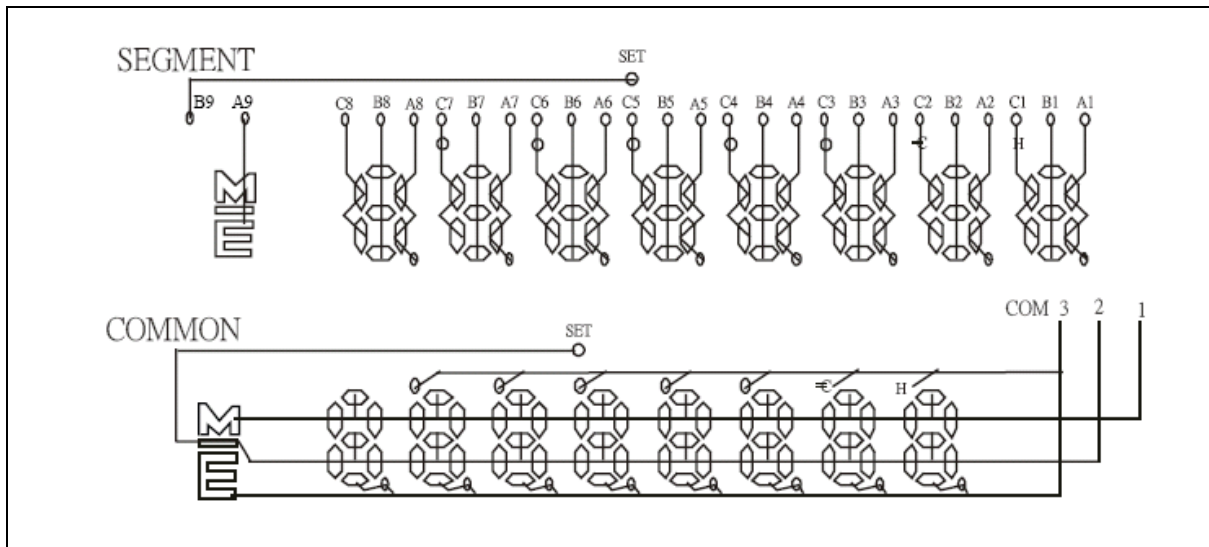

### E) Waveforms For Display

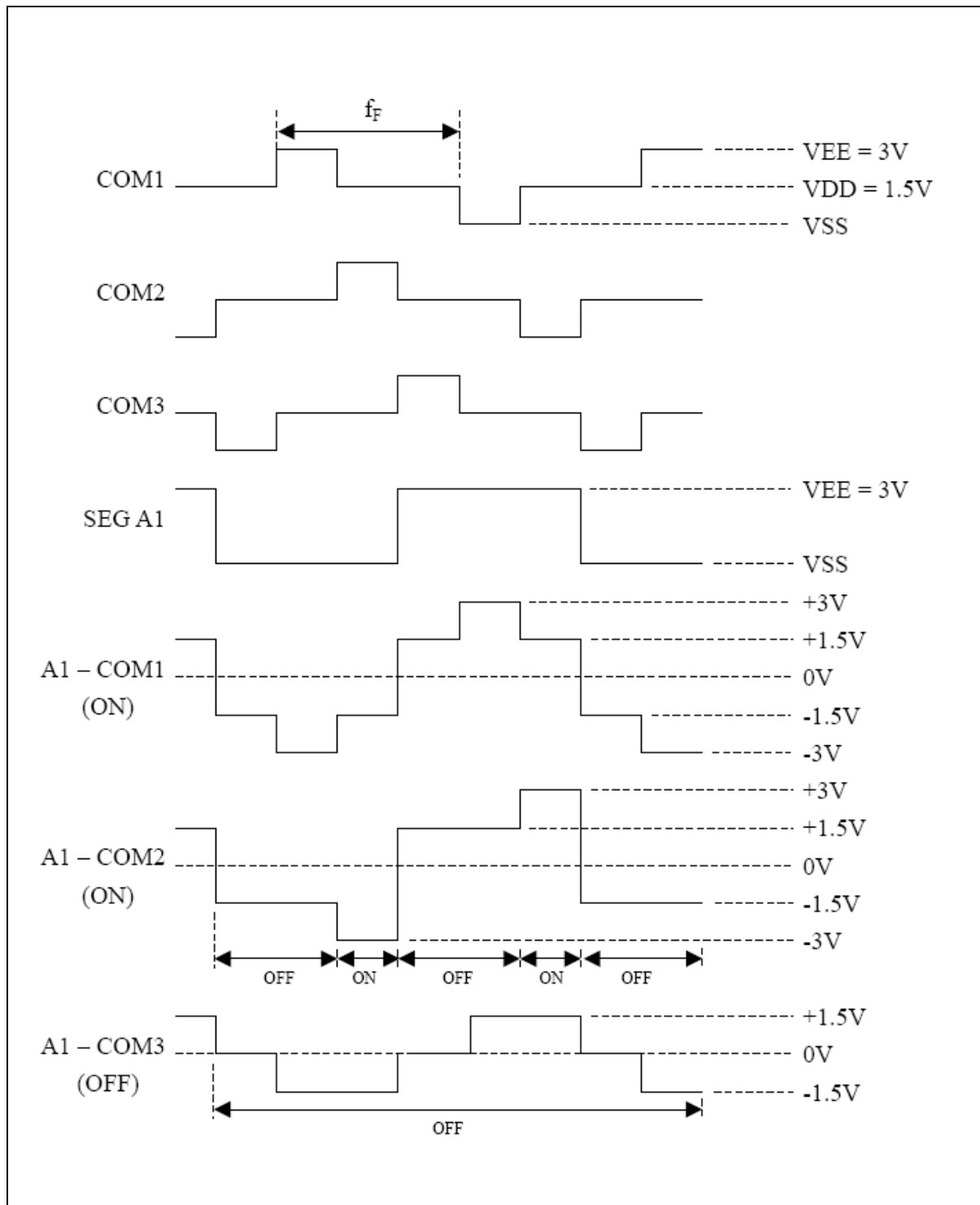



## 5 Absolute Maximum Ratings

Items	Sym.	Min.	Max.	Unit
Supply Voltage	VDD-VSS	-0.3	2.0	V
Input Voltage	VIN	-0.3	VDD+0.3	V
Operating Temperature	TOP	0	50	°C
Storage Temperature	TSTG	-55	+125	°C

## 6 Electrical Characteristics

(VDD=1.5V+0.3V, VSS=0V, TA=25 °C, VEE=3.0+0.4V)

Parameter	Pin Name	Sym.	Min.	Typ.	Max.	Unit	Condition
Operating Voltage	-	VDD	1.2	1.5	1.8	V	
"1" Input Voltage	K3~K10	VIH(1)	VDD-0.4	-	VDD	V	
"1" Input Voltage	K11~K14	VIH(2)	VEE-0.4	-	VEE	V	
"0" Input Voltage	K3~K14	VIL(1)	0	-	0.4	V	
"1" Input Voltage	RESET	VIH(3)	0.6 VDD	-	VDD	V	VDD=1.5V
"0" Input Voltage	RESET	VIL(2)	0	-	0.4 VDD	V	VDD=1.5V
"1" Output Voltage	SEGMENT COM1~3	VOH(1)	VEE-0.2	-	VEE	V	
"0" Output Voltage	SEGMENT COM1~3	VOL(1)	0	-	0.2	V	
"M" Output Voltage	COM1~3	VOM	VDD-0.2	-	VDD+0.2	V	
"1" Output Voltage	K0~K7	VOH(2)	VDD-0.2	-	VDD	V	
"0" Output Voltage	K0~K7	VOL(2)	0	-	0.2	V	
"1" Output Resistance	SEGMENT COM1~3	ROH	-	-	70	KΩ	VOUT=VEE-0.5V
"0" Output Resistance	SEGMENT COM1~3	ROL	-	-	70	KΩ	VOUT=0.5V



Parameter	Name	Sym.	Min.	Typ.	Max.	Unit	Condition
Key Pull Down Resistance	K0~K10	RKEYL(1)	100	180	650	KΩ	VOUT=VDD= 1.2~1.8V
Key Pull Up Resistance	K0~K7	RKEYH(1)	-	-	10	KΩ	VOUT=0.5V
	RESET	RKEYH(2)	50	-	370	KΩ	
Switch Pull Down Resistance	K11~K14	RSW(1)	240	400	800	KΩ	VOUT=VEE
Oscillating Frequency	(Wait) TS1	FWAIT	10.8	18	25.2	KHz	VDD=1.2 ~ 1.8V
	(Operate) TS1	FOP	120	200	280	KHz	
Frame Frequency	SEGMENT COM1~3	fF	56.3	93.8	131.3	Hz	Wait clock
			62.5	104	145.6	Hz	Fast clock
Supply Current	1 (WAIT)	IDDWAIT	-	3.0	4.5	μ	VDD=1.5V, no load
	2 (OPERATE)	IDDOP	-	13	20	μ	VDD=1.5V, no load
	3 (OFF)	IDDOFF	-	-	1.0	μ	VDD=1.5V, no load

## 7 Application Circuit

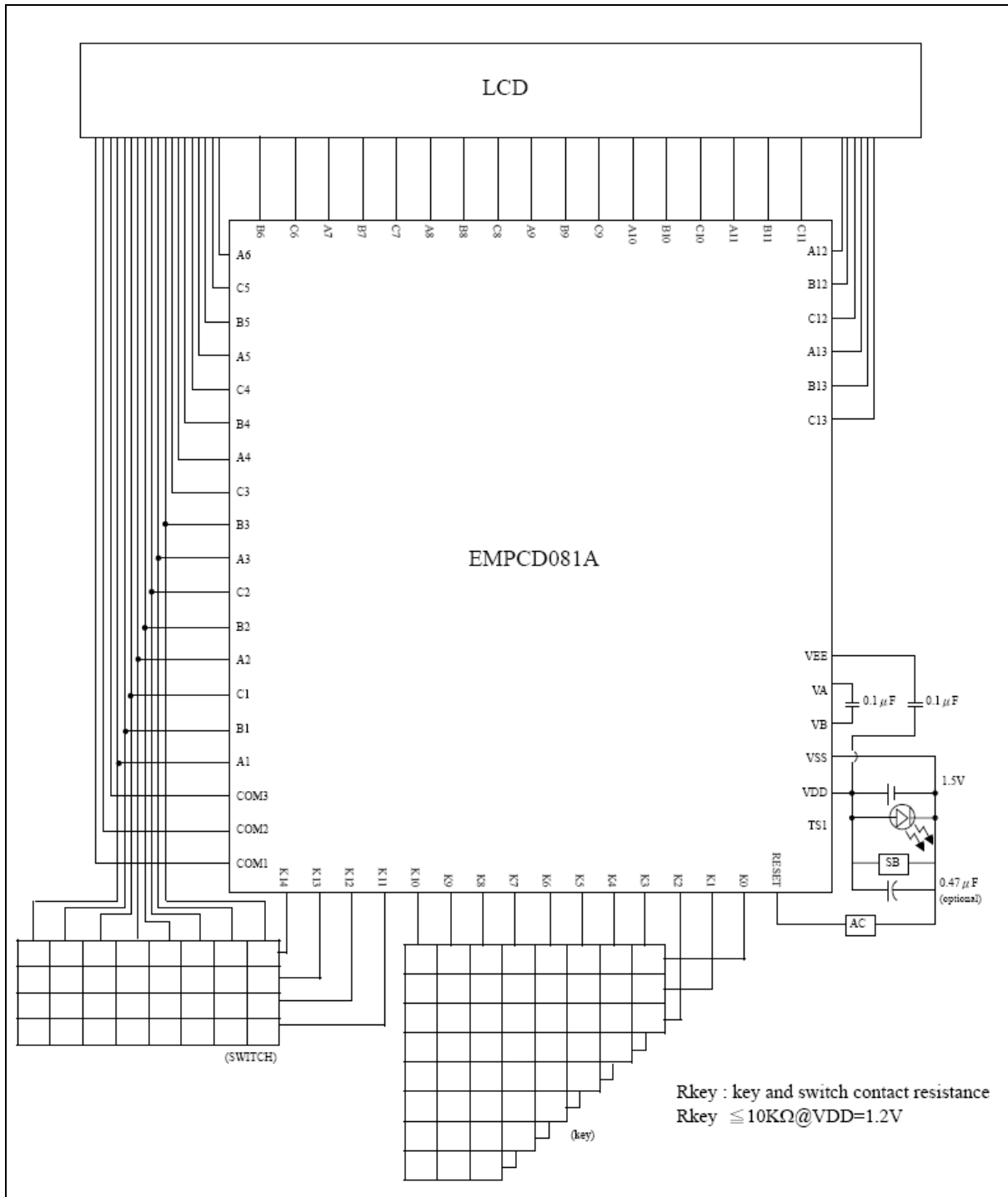



## 8 Pad Diagram

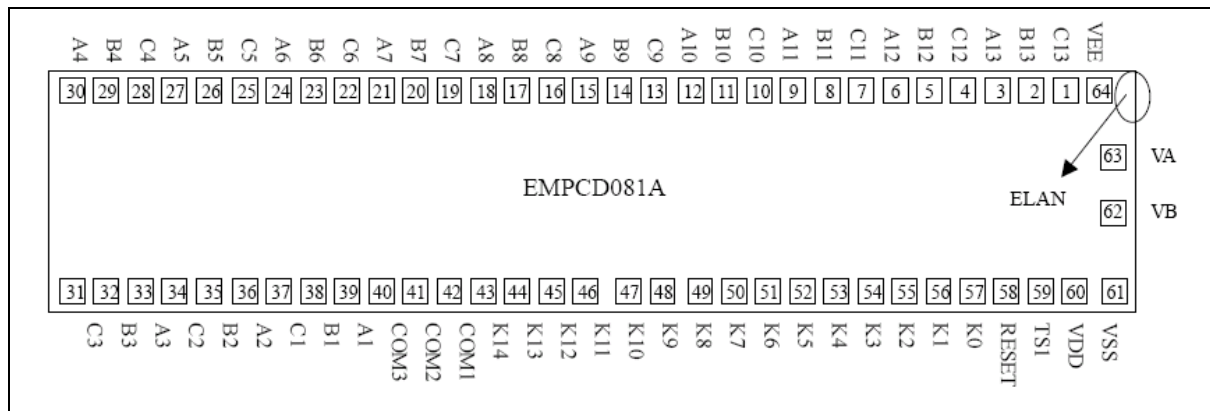

Pad No.	Symbol	X	Y
1	C13	1510.0	350.0
2	B13	1400.0	350.0
3	A13	1290.0	350.0
4	C12	1180.0	350.0
5	B12	1070.0	350.0
6	A12	960.0	350.0
7	C11	850.0	350.0
8	B11	740.0	350.0
9	A11	630.0	350.0
10	C10	520.0	350.0
11	B10	410.0	350.0
12	A10	300.0	350.0
13	C9	190.0	350.0
14	B9	80.0	350.0
15	A9	-30.0	350.0
16	C8	-140.0	350.0
17	B8	-250.0	350.0
18	A8	-360.0	350.0
19	C7	-470.0	350.0
20	B7	-580.0	350.0
21	A7	-690.0	350.0
22	C6	-800.0	350.0
23	B6	-910.0	350.0
24	A6	-1020.0	350.0
25	C5	-1130.0	350.0



Pad No.	Symbol	X	Y
26	B5	-1240.0	350.0
27	A5	-1350.0	350.0
28	C4	-1460.0	350.0
29	B4	-1570.0	350.0
30	A4	-1680.0	350.0
31	C3	-1680.0	-350.0
32	B3	-1570.0	-350.0
33	A3	-1460.0	-350.0
34	C2	-1350.0	-350.0
35	B2	-1240.0	-350.0
36	A2	-1130.0	-350.0
37	C1	-1020.0	-350.0
38	B1	-910.0	-350.0
39	A1	-800.0	-350.0
40	COM3	-690.0	-350.0
41	COM2	-580.0	-350.0
42	COM1	-470.0	-350.0
43	K14	-360.0	-350.0
44	K13	-250.0	-350.0
45	K12	-140.0	-350.0
46	K11	-30.0	-350.0
47	K10	98.0	-350.0
48	K9	208.0	-350.0
49	K8	318.0	-350.0
50	K7	428.0	-350.0
51	K6	538.0	-350.0
52	K5	648.0	-350.0
53	K4	758.0	-350.0
54	K3	868.0	-350.0
55	K2	978.0	-350.0
56	K1	1088.0	-350.0
57	K0	1198.0	-350.0
58	RESET	1308.0	-350.0
59	TS1	1418.0	-350.0
60	VDD	1540.1	-350.0
61	VSS	1666.7	-350.0
62	VB	1675.0	-59.3
63	VA	1675.0	130.7
64	VEE	1634.0	350.0

Chip size:3620 x 1010 um

**NOTE**

*For PCB layout, IC substrate must be connected to VSS.*

