

Dual High-Voltage Trench Barrier Schottky Rectifier

Product Summary:

V_{RRM}	100V
$V_F @ I_F=10A$	0.58V
$I_{F(AV)}$	2 x 10A

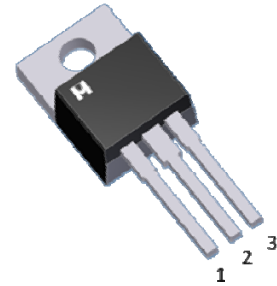
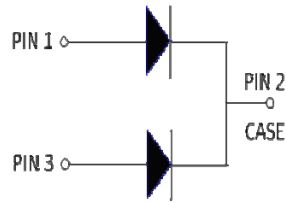

Trench Schottky Technology

Pb-Free Lead Plating & Halogen Free



ABSOLUTE MAXIMUM RATINGS ($T_A = 25\text{ }^\circ\text{C}$ Unless Otherwise Noted)

PARAMETERS/TEST CONDITIONS		SYMBOL	LIMITS	UNIT
Maximum Repetitive Peak Reverse Voltage		V_{RRM}	100	V
Maximum Average Forward Rectified Current	Per device	$I_{F(AV)}$	20	A
	Per diode		10	
Peak Forward Surge Current 8.3ms Single Half Sine-wave Superimposed on Rated Load per Diode		I_{FSM}	150	
Peak Repetitive Reverse Current @ $t_p = 2\text{ }\mu\text{s}$, 1 kHz, $T_j = 38\text{ }^\circ\text{C} \pm 2\text{ }^\circ\text{C}$ per Diode		I_{RRM}	1	
Non-repetitive Avalanche Energy @ $T_j = 25\text{ }^\circ\text{C}$, L = 60 mH per Diode		E_{AS}	150	mJ
Voltage rate of change (rated V_R)		dV/dt	10000	V/ μs
Operating Junction & Storage Temperature Range		T_j, T_{stg}	-40 to 150	$^\circ\text{C}$

THERMAL RESISTANCE RATINGS

THERMAL RESISTANCE	SYMBOL	TYPICAL	MAXIMUM	UNIT
Junction-to-Case	$R_{\theta JC}$		2.8	$^\circ\text{C}/\text{W}$

¹Pulse width limited by maximum junction temperature.

²Duty cycle $\leq 1\%$



ELECTRICAL CHARACTERISTICS ($T_A = 25\text{ }^\circ\text{C}$, Unless Otherwise Noted)

PARAMETER	SYMBOL	TEST CONDITIONS		LIMITS			UNIT
				MIN	TYP	MAX	
Breakdown Voltage	V_{BR}	$I_R=1.0\text{mA}$		100			V
Instantaneous Forward Voltage per Diode	V_F^1	$I_F=5\text{A}$	$T_A = 25\text{ }^\circ\text{C}$		0.55		V
		$I_F=10\text{A}$			0.65	0.79	
		$I_F=5\text{A}$	$T_A = 125\text{ }^\circ\text{C}$		0.50		
		$I_F=10\text{A}$			0.58	0.68	
Reverse Current per Diode	I_R^2	$V_R = 70\text{V}$	$T_A = 25\text{ }^\circ\text{C}$		5		μA
			$T_A = 125\text{ }^\circ\text{C}$		6		mA
		$V_R = 100\text{V}$	$T_A = 25\text{ }^\circ\text{C}$		15	500	μA
			$T_A = 125\text{ }^\circ\text{C}$		15	35	mA

¹Pulse test : 300 μs Pulse Width, 1% Duty Cycle.

²Pulse Width $\leq 40\text{ms}$.



Ordering & Marking Information:

Device Name: EMS20D10E for TO-220

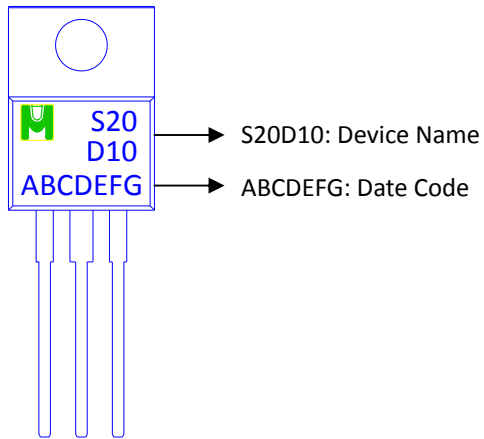

Outline Drawing

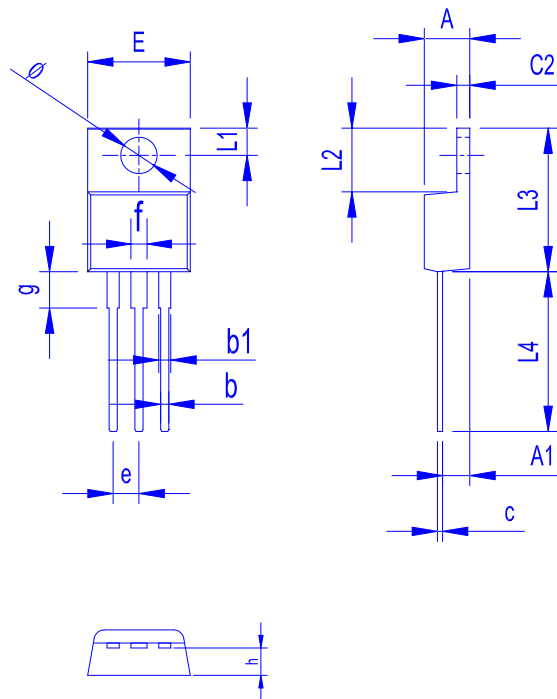

Dimension in mm

Dimension	A	b	b1	c	c2	E	L1	L2	L3	L4	ø	e	f	g	h
Min.	4.20	0.70	0.90	0.30	1.10	9.80	2.55	6.10	14.80	13.50	3.40	2.35	1.30	3.40	2.40
Max.	4.80	1.10	1.50	0.70	1.50	10.50	2.85	6.50	15.40	14.50	3.80	2.75	1.90	3.80	3.00

