

Features

- 3.3 and 5 VDC voltage supply option
- Absolute
- Bushing or servo mount
- Non-contacting magnetic technology
- Small size
- CMOS and TTL compatible
- Resolution: 1024 positions
- Long life
- High operating speed
- Highly repeatable
- Sealed option
- Magnetic technology

EMS22A - Non-Contacting Absolute Encoder

Electrical Characteristics

Resolution	1024 positions
Insulation Resistance (500 VDC)	1,000 megohms
Electrical Travel	Continuous
Supply Voltage	5.0 VDC $\pm 10\%$, 3.3 VDC $\pm 10\%$
Supply Current	20 mA maximum
Output Voltage	
Low Output Level	V _{ss} +0.4 V maximum
High Output Level	V _{dd} -0.5 V minimum
Output Current	
With 4.5 VDC Supply Voltage	4 mA maximum
With 3.0 VDC Supply Voltage	2 mA maximum
Rise/Fall Time (Incremental Output)	500 ns maximum
Shaft RPM (Ball Bearing)	10,000 rpm maximum
Linearity	0.5 %
Accuracy	
Nominal	$\pm 0.7^\circ$ or better
Worst Case	$\pm 1.4^\circ$
Output Transition Noise	0.12 ° RMS max.

Environmental Characteristics

Operating Temperature Range	-40 °C to +125 °C (-40 °F to +257 °F)
Storage Temperature Range	-55 °C to +125 °C (-67 °F to +257 °F)
Humidity	MIL-STD-202, Method 103B, Condition B
Vibration	15 G
Shock	50 G
Rotational Life	
S Bushing (@1,000 rpm)	100,000,000 revolutions
T & W Bushings (@1,000 rpm with 250 g side load)	50,000,000 revolutions
IP Rating	IP 65

Mechanical Characteristics

Mechanical Angle	360 ° Continuous
Torque	
Starting	43 ± 21 g-cm (0.6 ± 0.3 oz-in.)
Running	29 ± 14 g-cm (0.4 ± 0.2 oz-in.)
Mounting Torque	203 N-cm (18 lb.-in.)
Shaft End Play	0.30 mm (0.012 ") T.I.R. maximum
Shaft Radial Play	0.12 mm (0.005 ") T.I.R. maximum
Weight11 gms. (0.4 oz.)
Terminals	Axial, radial or ribbon cable
Soldering Condition	
Manual Soldering	96.5Sn/3.0Ag/0.5Cu solid wire or no-clean rosin cored wire 370 °C (700 °F) max. for 3 seconds
Wave Soldering	96.5Sn/3.0Ag/0.5Cu solder with no-clean flux 260 °C (500 °F) max. for 10 seconds
Wash processes	Not recommended
Marking	Manufacturer's trademark, name, part number, and date code.
Hardware	One lockwasher and one mounting nut supplied with each encoder, except on servo mount versions.

Pin Configuration

Output Type	Pin 1 (DI)	Pin 2 (CLK)	Pin 3	Pin 4 (DO)	Pin 5	Pin 6
Absolute	Digital Input	Clock	GND	Digital Output	VCC*	CS

* Can be 5 or 3.3 VDC depending on the version.

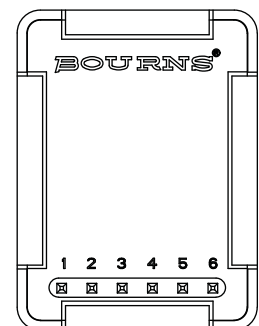

*RoHS Directive 2002/95/EC Jan. 27, 2003 including annex and RoHS Recast 2011/65/EU June 8, 2011.

Specifications are subject to change without notice.

The device characteristics and parameters in this data sheet can and do vary in different applications and actual device performance may vary over time.

Users should verify actual device performance in their specific applications.

Applications

- Material handling equipment
- Brushless DC motor commutation
- Robotics
- Automotive
- Industrial automation
- Petroleum refinery
- Medical
- Office equipment
- Audio and broadcast equipment

EMS22A - Non-Contacting Absolute Encoder

BOURNS®

Output Type Waveform and Variant Table

Absolute Output

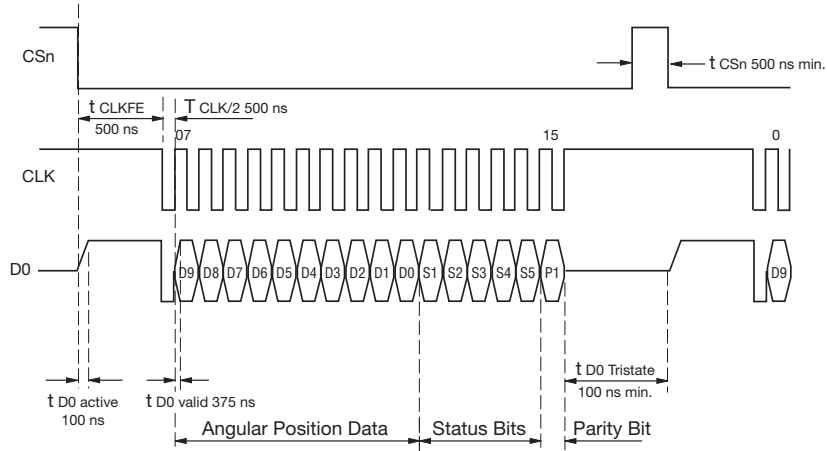

Data Content	Description
D9:D0	Absolute angular position data
S1	End of offset compensation algorithm
S2	Cordic overflow indicating an error in cordic part
S3	Linearity alarm
S4	Increase in magnitude
S5	Decrease in magnitude
P1	Even parity for detecting bits 1-15 transmission error

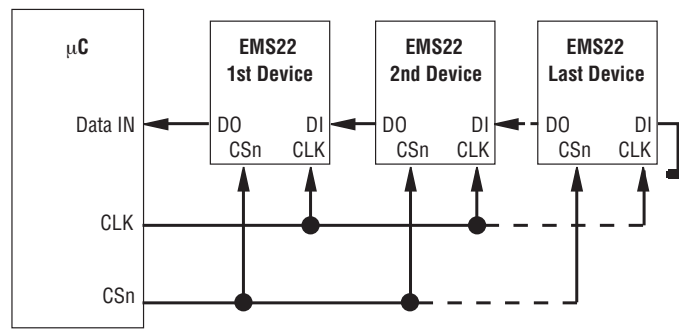

Daisy Chain Hardware Configuration

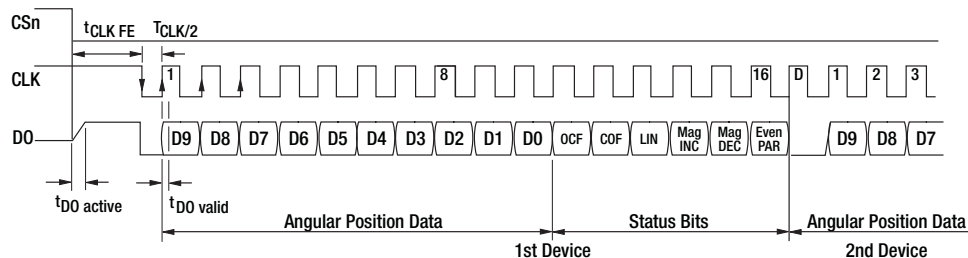

Daisy Chain Mode Data Transfer

Specifications are subject to change without notice.
 The device characteristics and parameters in this data sheet can and do vary in different applications and actual device performance may vary over time.
 Users should verify actual device performance in their specific applications.

Consult factory for options not shown, including:

- Wire lead or cable options
- Special shaft/bushing sizes and features
- Connectors
- Special performance characteristics
- Non-standard resolutions
- PCB mounting bracket

EMS22A - Non-Contacting Absolute Encoder

BOURNS®

Product Dimensions

Shaft Style D (Bushing T)

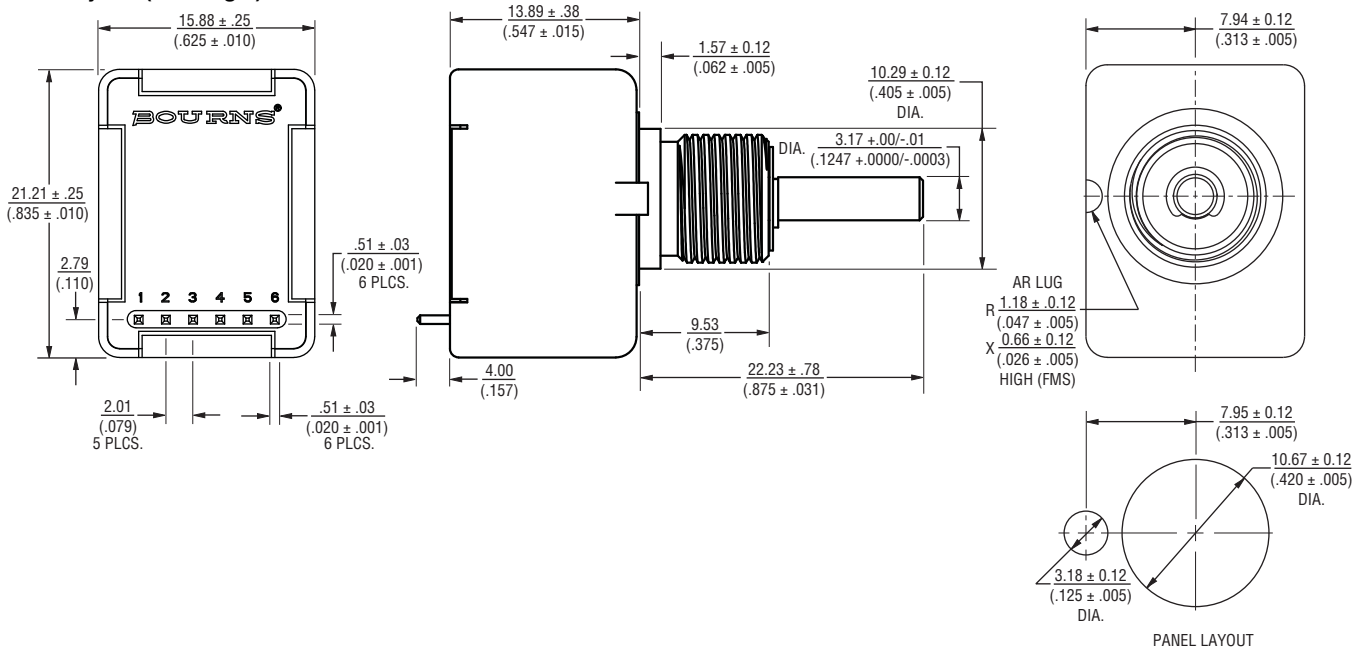

Shaft Style B (Bushing S)

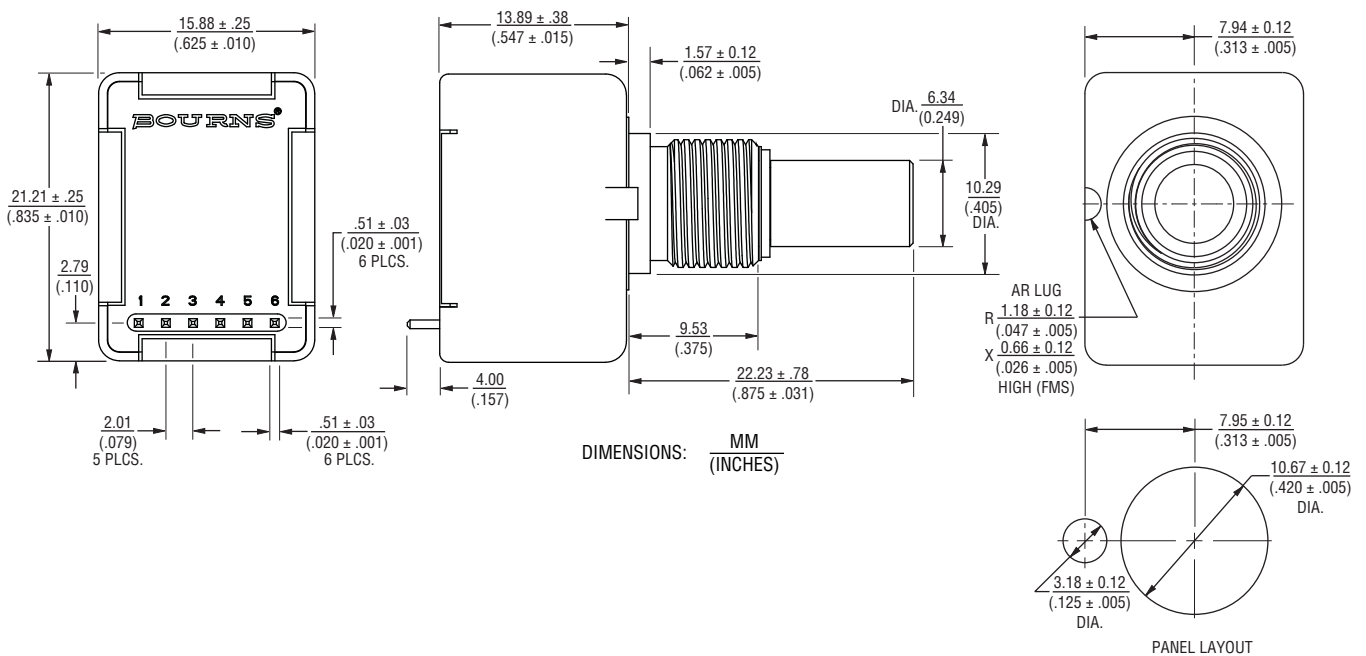

Specifications are subject to change without notice.

The device characteristics and parameters in this data sheet can and do vary in different applications and actual device performance may vary over time. Users should verify actual device performance in their specific applications.

EMS22A - Non-Contacting Absolute Encoder

BOURNS®

Product Dimensions

Shaft Style D (Bushing W)

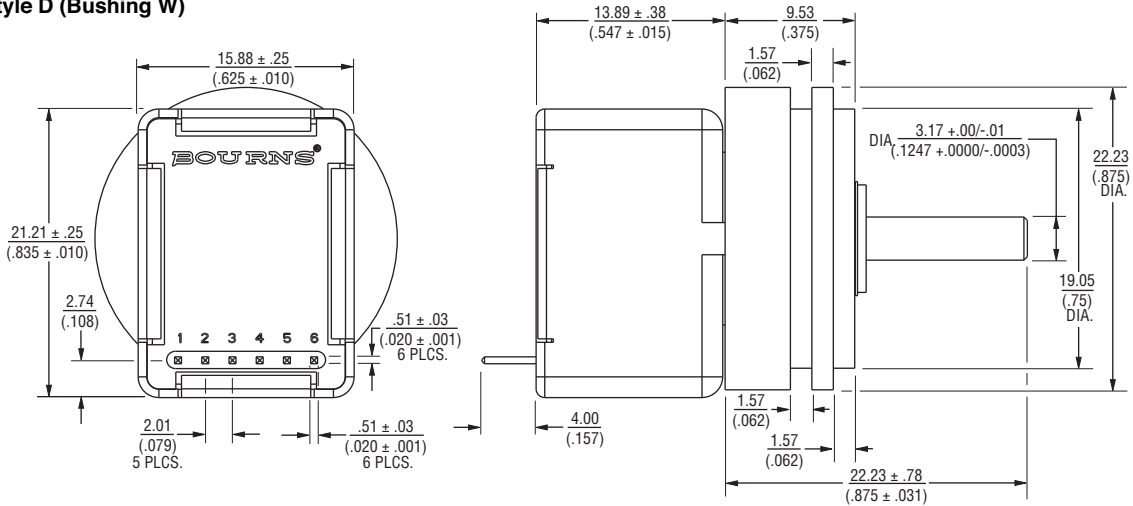

Cable Assembly

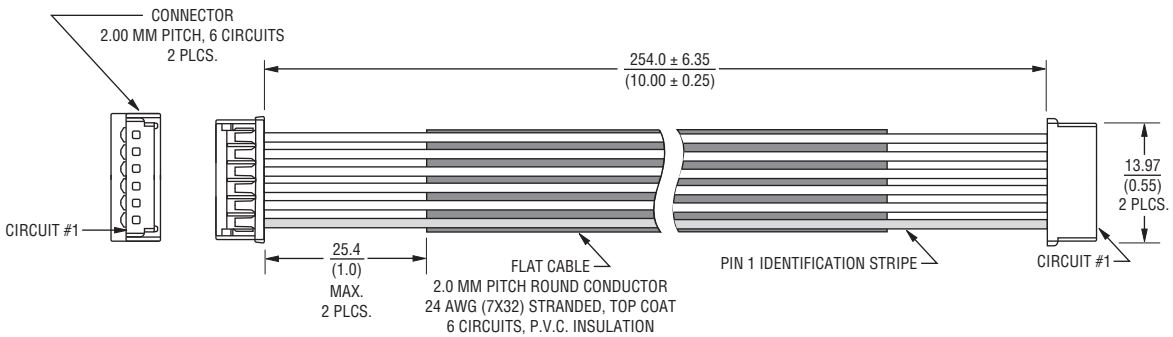

DIMENSIONS: $\frac{\text{MM}}{\text{(INCHES)}}$

EMS22A - Non-Contacting Absolute Encoder

BOURNS®

How To Order

