

## Features

- 3.3 and 5 VDC voltage supply option
- Direction/Step output (Tachometer)
- Bushing or servo mount
- Non-contacting magnetic technology
- Small size
- CMOS and TTL compatible
- Resolution from 64-512 PPR
- Long life
- High operating speed
- Highly repeatable
- Sealed option
- Magnetic technology

## EMS22D - Non-Contacting Direction/Step Encoder

### Electrical Characteristics

Resolution .....	64 to 512 PPR
Insulation Resistance (500 VDC) .....	1,000 megohms
Electrical Travel .....	Continuous
Supply Voltage .....	5.0 VDC $\pm 10\%$ , 3.3 VDC $\pm 10\%$
Supply Current .....	20 mA maximum
Output Voltage	
Low Output Level .....	V <sub>ss</sub> +0.4 V maximum
High Output Level .....	V <sub>dd</sub> -0.5 V minimum
Output Current	
With 4.5 VDC Supply Voltage .....	4 mA maximum
With 3.0 VDC Supply Voltage .....	2 mA maximum
Rise/Fall Time (Incremental Output) .....	500 ns maximum
Shaft RPM (Ball Bearing) .....	10,000 rpm maximum
Hysteresis .....	0.7 °
Accuracy	
Nominal .....	$\pm 0.7^\circ$ or better
Worst Case .....	$\pm 1.4^\circ$
Output Transition Noise .....	0.12 ° RMS max.

### Environmental Characteristics

Operating Temperature Range .....	-40 °C to +125 °C (-40 °F to +257 °F)
Storage Temperature Range .....	-55 °C to +125 °C (-67 °F to +257 °F)
Humidity .....	MIL-STD-202, Method 103B, Condition B
Vibration .....	15 G
Shock .....	50 G
Rotational Life	
S Bushing (@1,000 rpm) .....	100,000,000 revolutions
T & W Bushings (@1,000 rpm with 250 g side load) .....	50,000,000 revolutions
IP Rating .....	IP 65

### Mechanical Characteristics

Mechanical Angle .....	360 ° Continuous
Torque	
Starting .....	43 $\pm 21$ g-cm (0.6 $\pm 0.3$ oz-in.)
Running .....	29 $\pm 14$ g-cm (0.4 $\pm 0.2$ oz-in.)
Mounting Torque .....	203 N-cm (18 lb.-in.)
Shaft End Play .....	0.30 mm (0.012 ") T.I.R. maximum
Shaft Radial Play .....	0.12 mm (0.005 ") T.I.R. maximum
Weight .....	.11 gms. (0.4 oz.)
Terminals .....	Axial, radial or ribbon cable
Soldering Condition	
Manual Soldering .....	96.5Sn/3.0Ag/0.5Cu solid wire or no-clean rosin cored wire 370 °C (700 °F) max. for 3 seconds
Wave Soldering .....	96.5Sn/3.0Ag/0.5Cu solder with no-clean flux 260 °C (500 °F) max. for 10 seconds
Wash processes .....	Not recommended
Marking .....	Manufacturer's trademark, name, part number, and date code.
Hardware .....	One lockwasher and one mounting nut supplied with each encoder, except on servo mount versions.

### Pin Configuration

Output Type	Pin 1	Pin 2	Pin 3	Pin 4	Pin 5	Pin 6
Direction/Step	Pulse	Direction	GND	Index	VCC*	CS**

\* Can be 5 or 3.3 VDC depending on the version.

\*\* Active low chip select pin; if not used connect pin 6 to GND.

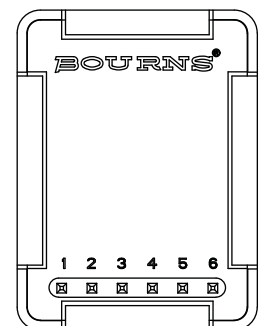

\*RoHS Directive 2002/95/EC Jan. 27, 2003 including annex and RoHS Recast 2011/65/EU June 8, 2011.

Specifications are subject to change without notice.

The device characteristics and parameters in this data sheet can and do vary in different applications and actual device performance may vary over time.

Users should verify actual device performance in their specific applications.

## Applications

- Material handling equipment
- Brushless DC motor commutation
- Robotics
- Automotive
- Industrial automation
- Petroleum refinery
- Medical
- Office equipment
- Audio and broadcast equipment

## EMS22D - Non-Contacting Direction/Step Encoder

**BOURNS®**

### Output Type Waveform and Variant Table

#### Direction/Step Output

PPR	3.3 Vcc	5.0 Vcc	Index 1	Index 3
512	X		X	
512	X			X
512		X	X	
512		X		X
256	X		X	
256	X			X
256		X	X	
256		X		X
128	X		X	
128	X			X
128		X	X	
128		X		X
64	X		X	
64	X			X
64		X	X	
64		X		X

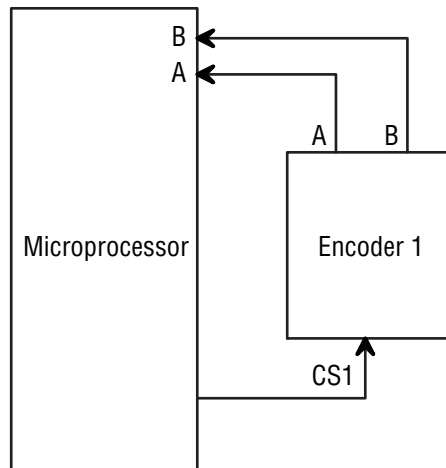
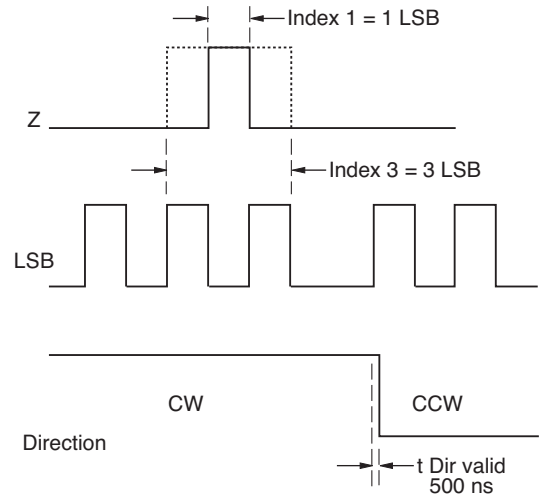

Chip Select Hardware Sample

Consult factory for options not shown, including:

- Wire lead or cable options
- Special shaft/bushing sizes and features
- Connectors
- Special performance characteristics
- Non-standard resolutions
- PCB mounting bracket

## EMS22D - Non-Contacting Direction/Step Encoder

**BOURNS®**

### Product Dimensions

#### Shaft Style D (Bushing T)

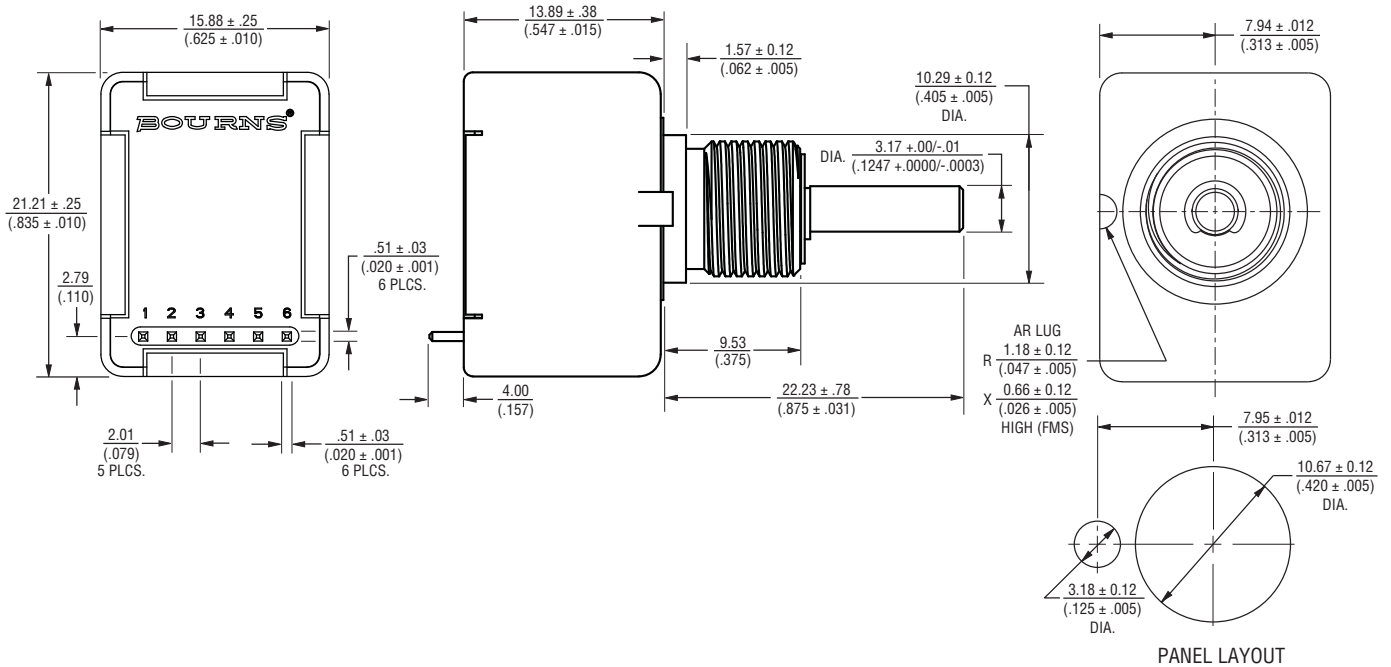

#### Shaft Style B (Bushing S)

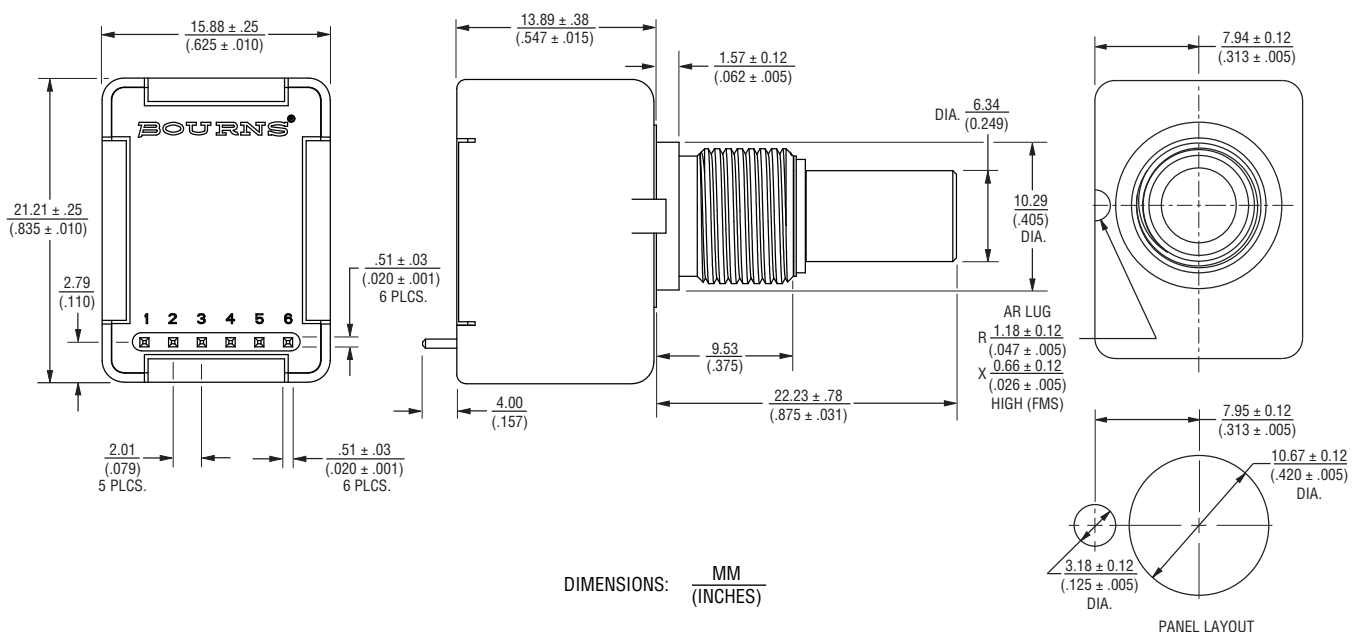

Specifications are subject to change without notice.

The device characteristics and parameters in this data sheet can and do vary in different applications and actual device performance may vary over time. Users should verify actual device performance in their specific applications.

# EMS22D - Non-Contacting Direction/Step Encoder

**BOURNS®**

## Product Dimensions (Continued)

### Shaft Style D (Bushing W)

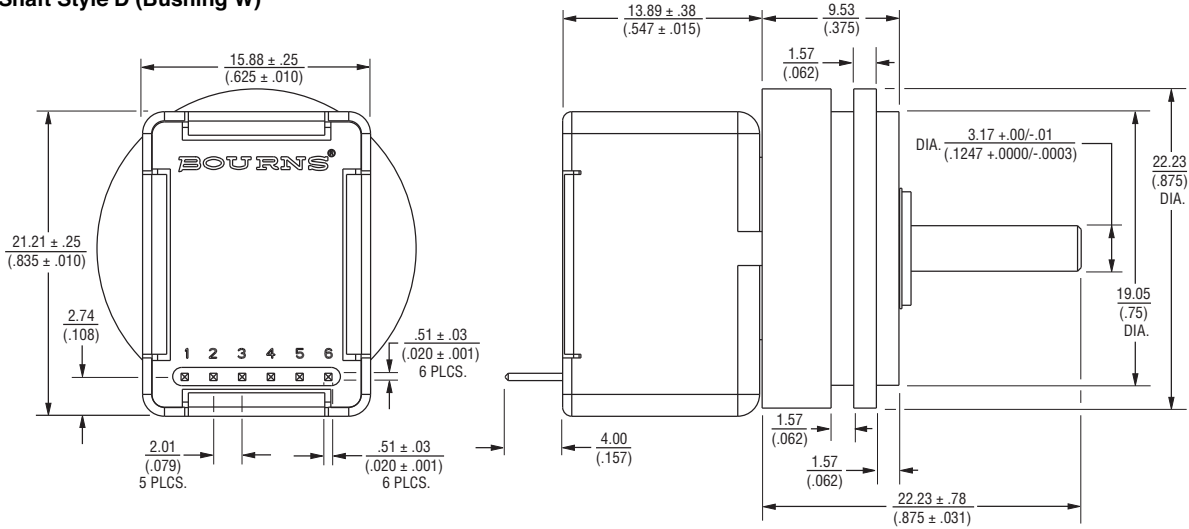

### Cable Assembly

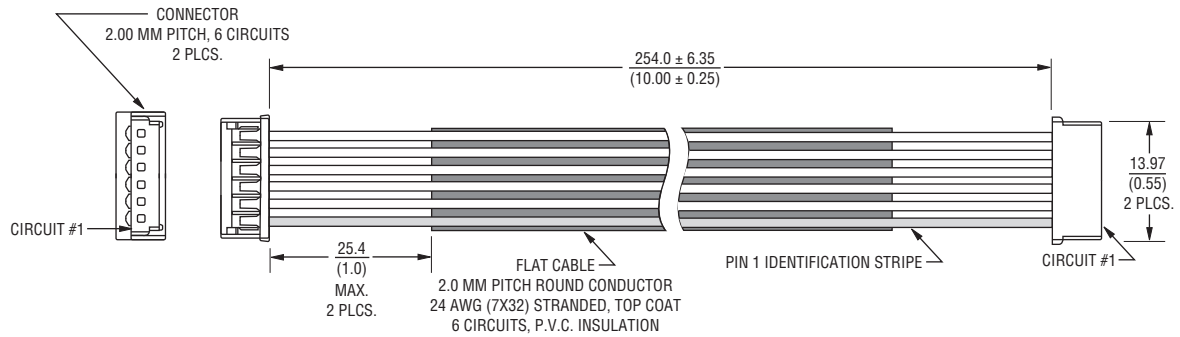

DIMENSIONS:  $\frac{\text{MM}}{\text{(INCHES)}}$

# EMS22D - Non-Contacting Direction/Step Encoder

**BOURNS®**

## How To Order

