

Features

- 3.3 and 5 VDC voltage supply option
- Quadrature output
- Bushing or servo mount
- Non-contacting magnetic technology
- Small size
- CMOS and TTL compatible
- Resolution from 32-256 PPR
- Long life
- High operating speed
- Highly repeatable
- Sealed output
- Magnetic technology

EMS22Q - Non-Contacting Incremental Encoder

Electrical Characteristics

Resolution	32 to 256 PPR
Insulation Resistance (500 VDC)	1,000 megohms
Electrical Travel	Continuous
Supply Voltage	5.0 VDC $\pm 10\%$, 3.3 VDC $\pm 10\%$
Supply Current	20 mA maximum
Output Voltage	
Low Output Level	V _{ss} +0.4 V maximum
High Output Level	V _{dd} -0.5 V minimum
Output Current	
With 4.5 VDC Supply Voltage	4 mA maximum
With 3.0 VDC Supply Voltage	2 mA maximum
Rise/Fall Time (Incremental Output)	500 ns maximum
Shaft RPM (Ball Bearing)	10,000 rpm maximum
Hysteresis	0.7 °
Accuracy	
Nominal	$\pm 0.7^\circ$ or better
Worst Case	$\pm 1.4^\circ$
Output Transition Noise	0.12 ° RMS max.

Environmental Characteristics

Operating Temperature Range	-40 °C to +125 °C (-40 °F to +257 °F)
Storage Temperature Range	-55 °C to +125 °C (-67 °F to +257 °F)
Humidity	MIL-STD-202, Method 103B, Condition B
Vibration	15 G
Shock	50 G
Rotational Life	
S Bushing (@1,000 rpm)	100,000,000 revolutions
T & W Bushings (@1,000 rpm with 250 g side load)	50,000,000 revolutions
IP Rating	IP 65

Mechanical Characteristics

Mechanical Angle	360 ° Continuous
Torque	
Starting	43 ± 21 g-cm (0.6 ± 0.3 oz-in.)
Running	29 ± 14 g-cm (0.4 ± 0.2 oz-in.)
Mounting Torque	203 N-cm (18 lb.-in.)
Shaft End Play	0.30 mm (0.012 ") T.I.R. maximum
Shaft Radial Play	0.12 mm (0.005 ") T.I.R. maximum
Weight11 gms. (0.4 oz.)
Terminals	Axial, radial or ribbon cable
Soldering Condition	
Manual Soldering	96.5Sn/3.0Ag/0.5Cu solid wire or no-clean rosin cored wire 370 °C (700 °F) max. for 3 seconds
Wave Soldering	96.5Sn/3.0Ag/0.5Cu solder with no-clean flux 260 °C (500 °F) max. for 10 seconds
Wash processes	Not recommended
Marking	Manufacturer's trademark, name, part number, and date code.
Hardware	One lockwasher and one mounting nut supplied with each encoder, except on servo mount versions.

Pin Configuration

Output Type	Pin 1	Pin 2	Pin 3	Pin 4	Pin 5	Pin 6
A/B Quadrature	A	B	GND	Index	VCC*	CS**

* Can be 5 or 3.3 VDC depending on the version.

** Active low chip select pin; if not used connect pin 6 to GND.

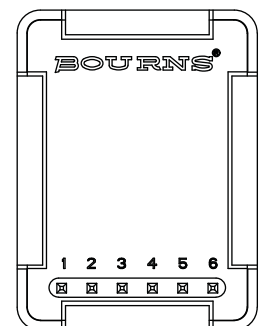

*RoHS Directive 2002/95/EC Jan. 27, 2003 including annex and RoHS Recast 2011/65/EU June 8, 2011.

Specifications are subject to change without notice.

The device characteristics and parameters in this data sheet can and do vary in different applications and actual device performance may vary over time.

Users should verify actual device performance in their specific applications.

Applications

- Material handling equipment
- Brushless DC motor commutation
- Robotics
- Automotive
- Industrial automation
- Petroleum refinery
- Medical
- Office equipment
- Audio and broadcast equipment

EMS22Q - Non-Contacting Incremental Encoder

BOURNS®

Output Type Waveform and Variant Table

Quadrature Output

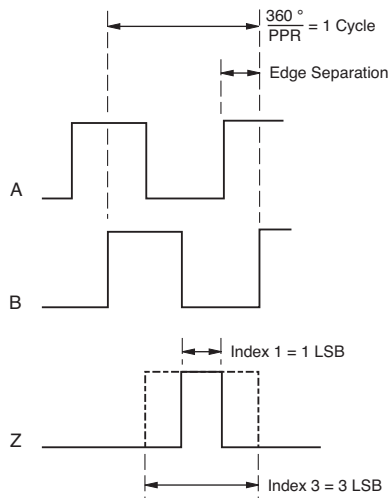

PPR	3.3 Vcc	5.0 Vcc	Index 1	Index 3
256	X		X	
256	X			X
256		X	X	
256		X		X
128	X		X	
128	X			X
128		X	X	
128		X		X
64	X		X	
64	X			X
64		X	X	
64		X		X
32	X		X	
32	X			X
32		X	X	
32		X		X

Minimum edge separation = $20 \times 256 / PPR$ (no missing pulses)

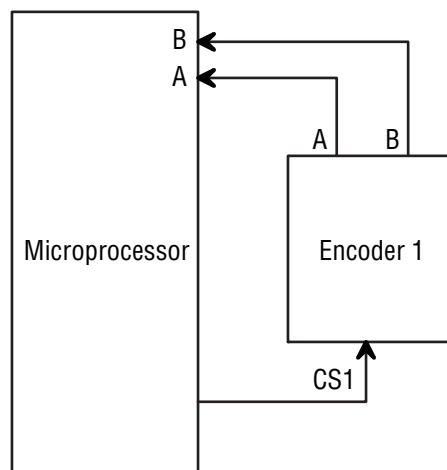

Chip Select Hardware Sample

Consult factory for options not shown, including:

- Wire lead or cable options
- Special shaft/bushing sizes and features
- Connectors
- Special performance characteristics
- Non-standard resolutions
- PCB mounting bracket

EMS22Q - Non-Contacting Incremental Encoder

BOURNS®

Dimensional Drawings

Shaft Style D (Bushing T)

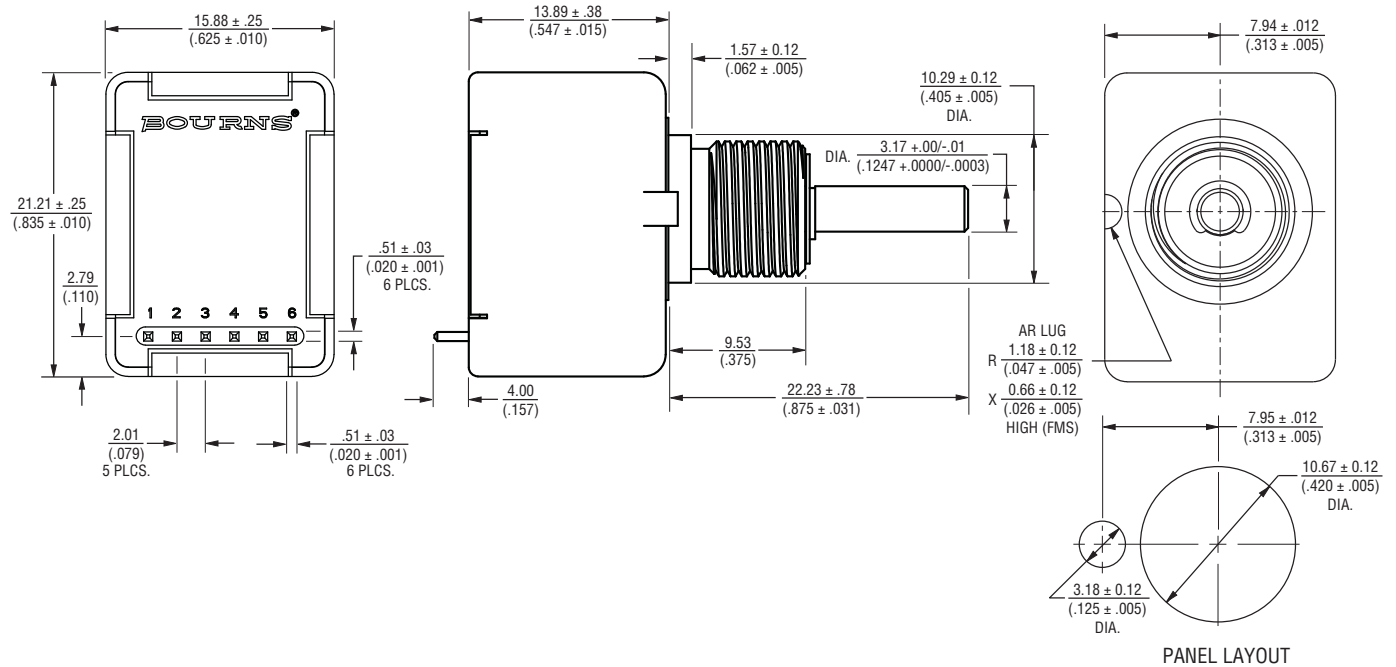

Shaft Style B (Bushing S)

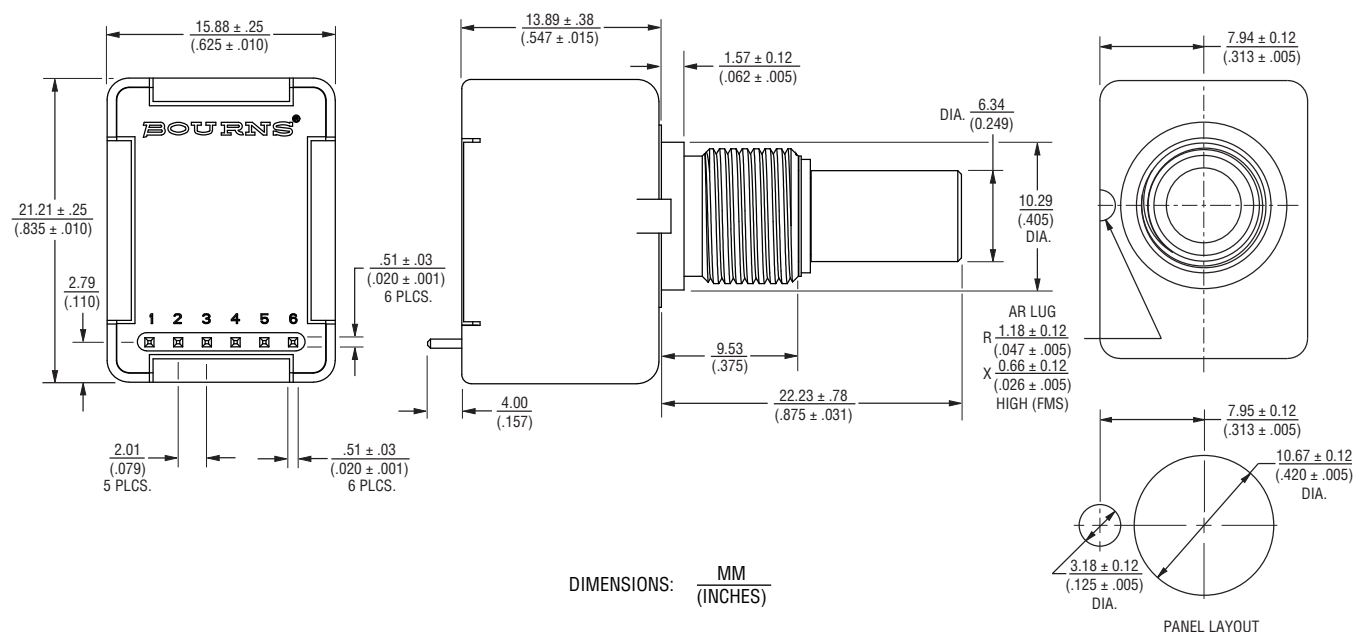

Specifications are subject to change without notice.

The device characteristics and parameters in this data sheet can and do vary in different applications and actual device performance may vary over time. Users should verify actual device performance in their specific applications.

EMS22Q - Non-Contacting Incremental Encoder

BOURNS®

Product Dimensions (Continued)

Shaft Style D (Bushing W)

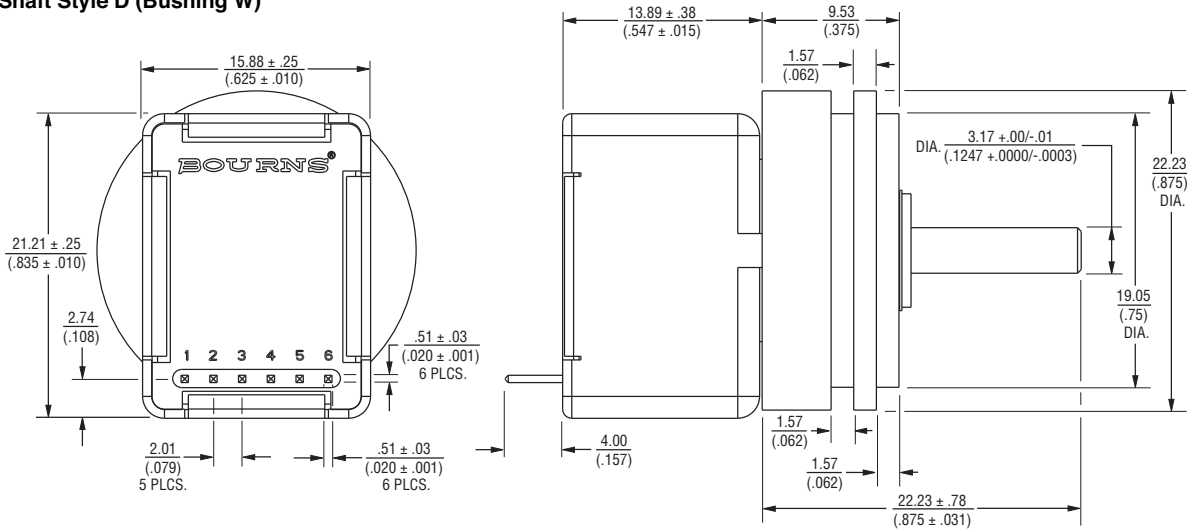

Cable Assembly

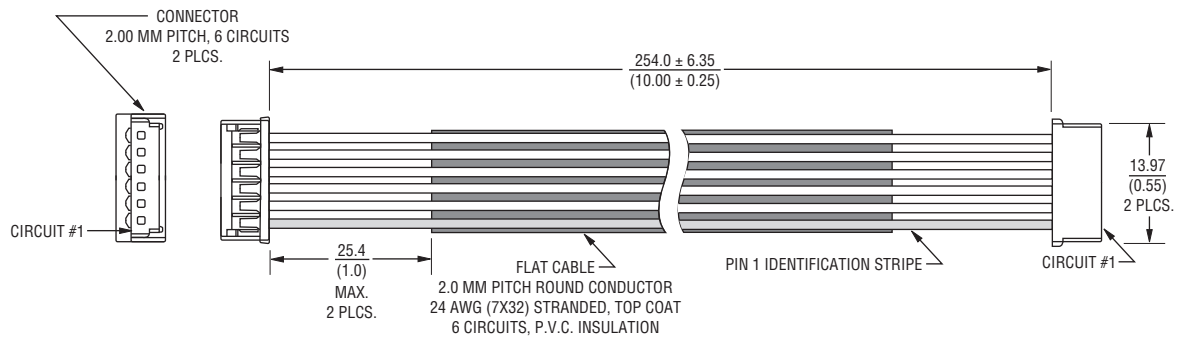

DIMENSIONS: $\frac{\text{MM}}{\text{(INCHES)}}$

EMS22Q - Non-Contacting Incremental Encoder

BOURNS®

How To Order

BOURNS EMS22 22 MM NON-CONTACTING INCREMENTAL ENCODER

E M S 2 2 Q 5 1 - B 2 8 - L S 4

INDEX CHANNEL	
Code	Description
1	1 LSB
3	3 LSB

SHAFT LENGTH DESIGNATOR*	
Code	Description
16	1/2 " Long
20	5/8 " Long
28	7/8 " Long
25	25 mm Long (Available with D Bushing Only)

RESOLUTION	
Code	PPR
1	32
2	64
3	128
4	256

VOLTAGE SUPPLY	
Code	Description
3	3.3 VDC
5	5 VDC

SHAFT STYLE		
Code	Description	Available With Bushings (Code)
B	1/4 " Dia., Plain End	S
C	1/4 " Dia., Flatted End	S
D	1/8 " Dia., Plain End	T, W
R	6 mm Dia., Slotted End	D
M	6 mm Dia., Flatted End	D

TERMINAL CONFIGURATION**	
Code	Description
L	Axial, Multi-Purpose Pin
M	Rear Ribbons Cable with Connector
W	Rear Ribbons Cable - No Connector

BUSHING DESIGNATOR	
Code	Description
S	3/8 " D X 3/8 " L Threaded (Single Ball Bearing)
T	3/8 " D X 3/8 " L Threaded (Dual Ball Bearing)
W	Servo Mount 7/8 " D (Dual Ball Bearing)
D	9 mm D X 7.94 mm L Threaded (Single Ball Bearing)

OUTPUT TYPE	
Code	Description
Q	Quadrature

* Shaft length measured from mounting surface.

** Standard ribbon cable is 10 inches long. Consult factory for other lengths.