

2A/2.5A Current-Limited Power Distribution Switches

General Description

The EMS6030 is an N-channel MOSFET high-side power switch without parasitic body diode between drain and source. The EMS6030 provides very low on-resistance as 60mΩ and continuously delivers up to 2A(EMS6030A/B) and 2.5A(EMS6030C/D) output current. The fault flag output function indicates fault conditions to the local USB controller. The other features include soft start, current limit protection, Power-On-Reset function, and over temperature protection. The EMS6030 is available in SOT-23-5L package.

Features

- Wide Input Range 2.5V to 5.5V
- Low MOSFET On Resistance(60mΩ)
- 2us Short Protection Response
- Low Quiescent(65uA) & Shutdown Current
- Deglitched Open-Drain Fault Flag Output
- Reverse Current Flow Blocking
- Power On Reset Function
- Current Limit Protection
- Over Temperature Protection
- Soft Start and Fast Turn Off
- Reverse Voltage Protection
- Enable Active High or Active Low

Ordering Information

Part Number	Package	Remark
EMS6030A	SOT-23-5	2A Active Low
EMS6030B	SOT-23-5	2A Active High
EMS6030C	SOT-23-5	2.5A Active Low
EMS6030D	SOT-23-5	2.5A Active High

Applications

- USB
- Notebook & Netbook & MB

Typical Application

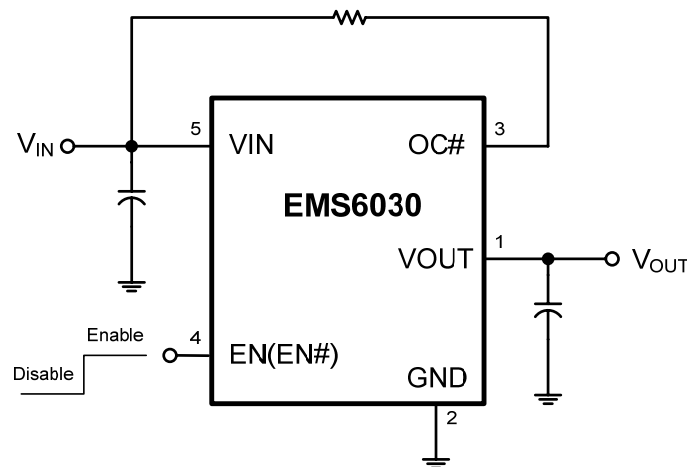
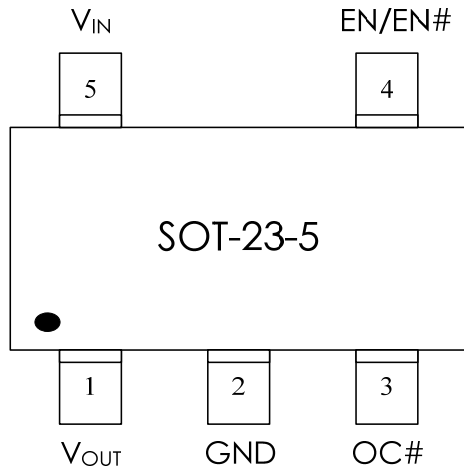

Fig. 1

Note: A low ESR 150uF capacitor between VIN, VOUT & GND is recommended.

Package Configuration



EMS6030X-VN05NRR

- X Output current
- VN05 SOT-23-5 Package
- NRR RoHS & Halogen free package
Rating: -40 to 85°C
Package in Tape & Reel

Order, Mark & Packing information

Package	Iout(A)	Product ID	Marking	Packing /MPQ
SOT-23-5	2.0	EMS6030A-VN05NRR		Tape & Reel 3Kpcs
		EMS6030B-VN05NRR		
SOT-23-5	2.5	EMS6030C-VN05NRR		
		EMS6030D-VN05NRR		

Functional Block Diagram

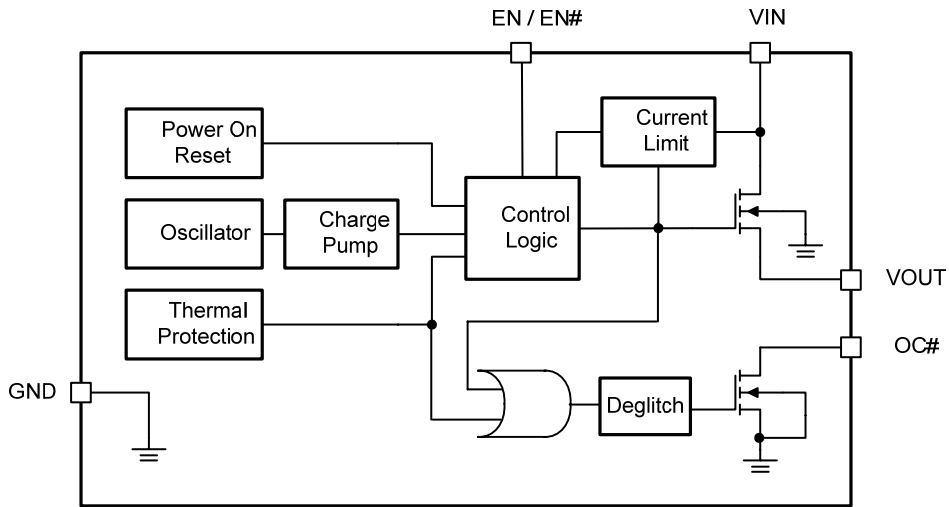

Fig. 2

Pin Functions

Pin Name	SOT-23-5	Function
VOUT	1	Output Voltage. VOUT is power output pin.
GND	2	Ground.
OC#	3	OC Flag Output. This is an open-drain output and is set low impedance once current limit or over temperature protection enabled.
EN/EN#	4	Chip Enable Input (Active high for EN, Active low for EN#)
VIN	5	Input Voltage. This is the drain input to the power device that supplies current to the output pin. Minimum 1uF low ESR ceramic capacitor is recommended at this pin.

Absolute Maximum Ratings_(Note1)

Devices are subjected to fail if they stay above absolute maximum ratings.

- Input Voltage ----- -0.3V to +6V
- Other Pins ----- -0.3V to (VIN+0.3V)
- Power Dissipation, PD@TA=25°C, SOT-23-5 ----- 0.4W
- Package Thermal Resistance, θ_{JA} , SOT-23-5 _(Note 2) ----- 250°C/W
- Junction Temperature ----- 150°C
- Lead Temperature (Soldering, 10 sec.) ----- 260°C
- Storage Temperature ----- -65°C to 150°C
- ESD susceptibility _(Note3)
 - HBM (Human Body Mode) ----- 2KV
 - MM (Machine Mode) ----- 200V

Recommended Operating Conditions_(Note4)

- Supply Input Voltage, V_{IN} ----- +2.5V to +5.5V
- Junction Temperature ----- -40°C to 125°C
- Ambient Temperature ----- -40°C to 85°C

Electrical Characteristics

- VIN=5V, TA=+25°C, unless otherwise specified.

Parameter	Symbol	Test Conditions	Min	Typ	Max	Units
Supply Input Section						
POR Threshold	V _{PORTH}		-	2.2	2.5	V
Quiescent Current	I _Q	I _{OUT} =0A	-	65	95	uA
Shutdown Current	I _{SD}	EN#=5V	-	0.1	1	uA
Output Voltage						
On Resistance	R _{ON}	I _{OUT} =0.5A, EMS6030A/B	-	60	80	mΩ
		I _{OUT} =0.5A, EMS6030C/D	-	60	70	
Reverse Leakage Current	I _{Rev}	V _{OUT} =5V, V _{IN} =0V	-	0.1	2	uA
Soft-Start Time		Rising from 10% to 90% CL=1uF; R _{LOAD} =10Ω	-	1.5	2	ms
Enable						
Enable High Level	V _{EN}		1.2	-	-	V
Disable Low Level	V _{SD}		-	-	0.5	V
EN Input Current	I _{EN}		-	0.1	1	uA
OC# Flag Output						
OC# Output Resistance	R _{FLGB}	I _{SINK} =1mA	-	20	80	Ω
OC# Off Current	I _{FLGB_OFF}	V _{FLGB} =5V	-	0.1	1	uA
OC# Delay Time	T _D		8	15	22	ms
OUT Shutdown Discharge Resistance	R _{DIS}		-	100	-	Ω

Electrical Characteristics (cont.)

- VIN=5V, TA=+25°C, unless otherwise specified.

Parameter	Symbol	Test Conditions	Min	Typ	Max	Units
Protection						
OCP Threshold Level	I _{OCP}	EMS6030A/B	2.4	3.2	3.9	A
		EMS6030C/D	2.6	3.2	3.9	A
Output Short Circuit Current	I _{SC}	EMS6030A/B	1.2	1.7	3	A
		EMS6030C/D	1.7	2.1	3	A
Thermal Shutdown Temperature	T _{SD}	EMS6030A/B	-	160	-	°C
		EMS6030C/D	-	150	-	
Thermal Shutdown Hysteresis	T _{SDHYS}		-	30	-	°C

- Note 1.** Stresses listed as the above "Absolute Maximum Ratings" may cause permanent damage to the device. These are for stress ratings. Functional operation of the device at these or any other conditions beyond those indicated in the operational sections of the specifications is not implied. Exposure to absolute maximum rating conditions for extended periods may remain possibility to affect device reliability.
- Note 2.** θ_{JA} is measured in the natural convection at TA=25°C on a low effective thermal conductivity test board (Single layout, 1S) of JEDEC 51-3 thermal measurement standard.
- Note 3.** Devices are ESD sensitive. Handling precaution is recommended.
- Note 4.** The device is not guaranteed to function outside its operating conditions.

Typical Performance Characteristics

■ $V_{IN}=5V, T_A=25^{\circ}C$, unless otherwise specified.

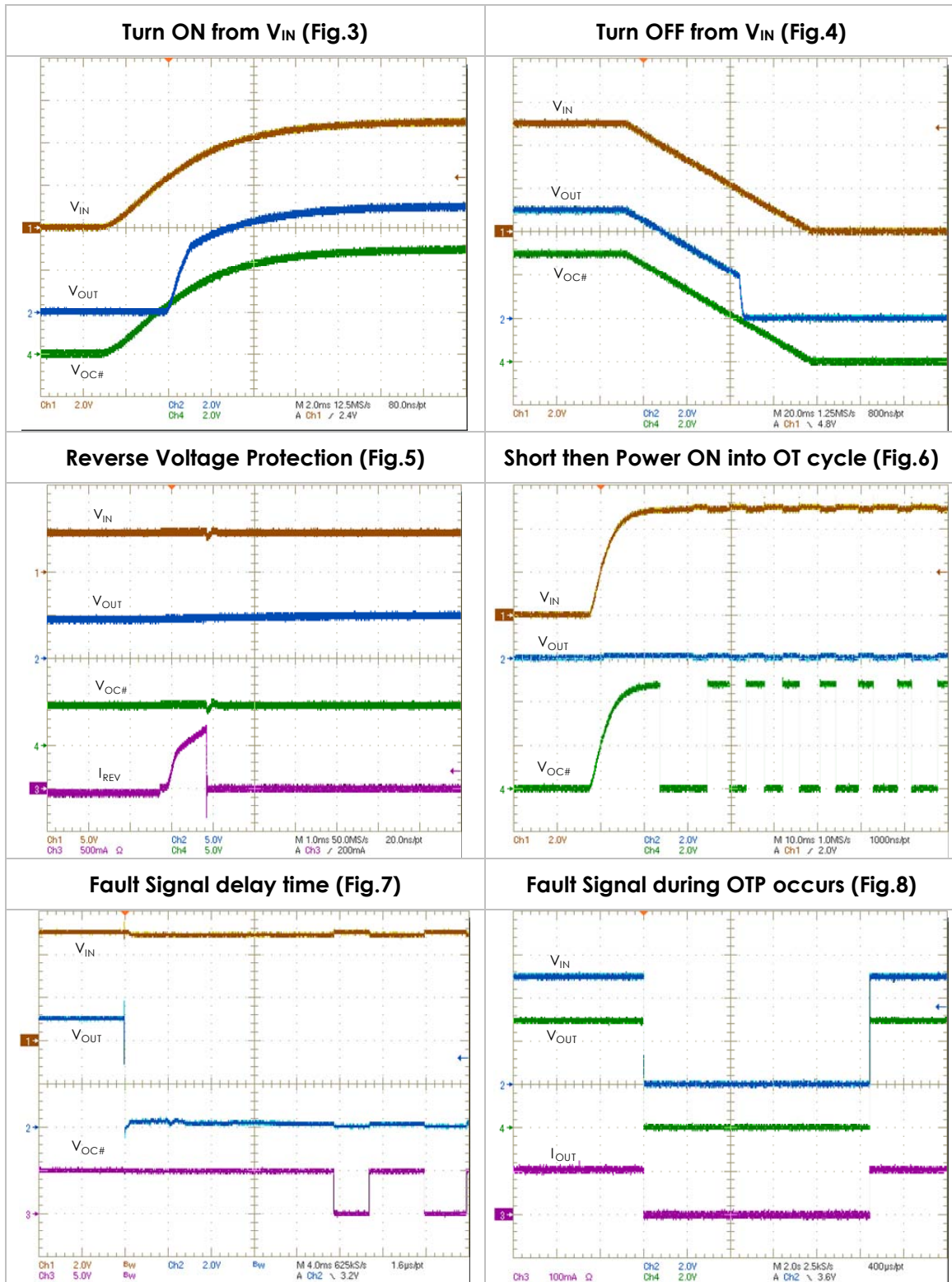

Typical Performance Characteristics (cont.)

■ $V_{IN}=5V$, $T_A=25^\circ C$, unless otherwise specified.

2us Response for output short protection (Fig.9)

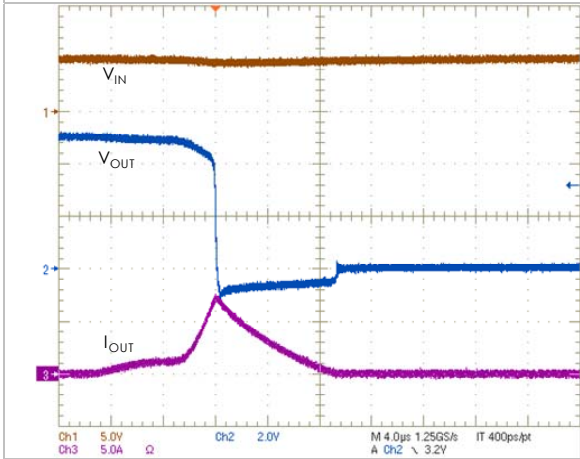

Normal operating 2A output current (Fig.10)

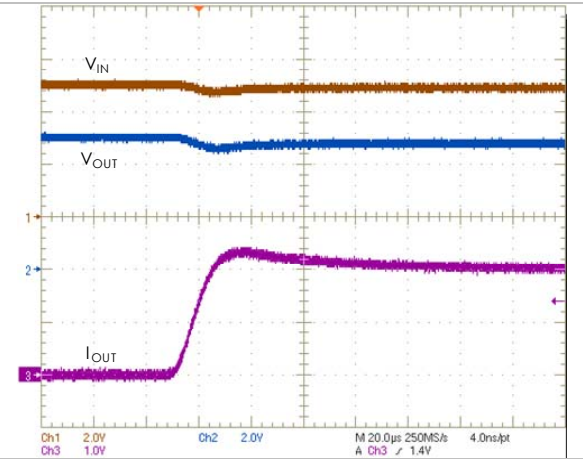

R_{ON} Performance vs. Temperature (Fig.11)

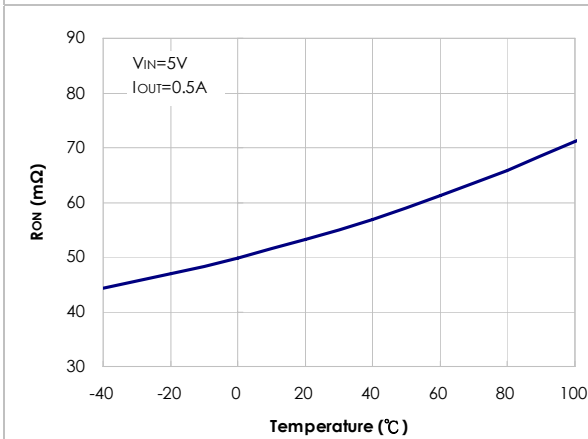

Shutdown Current vs. Input Voltage (Fig.12)

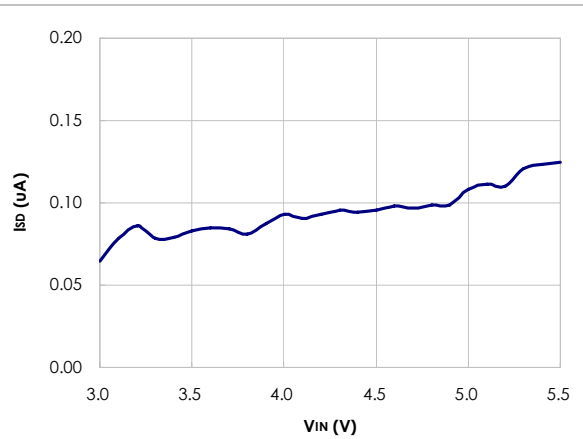

UVLO ON Voltage vs. Temperature (Fig.13)

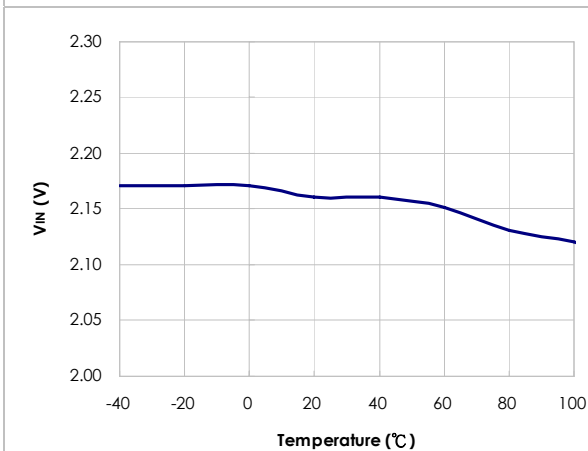

Enable Voltage vs. Temperature (Fig.14)

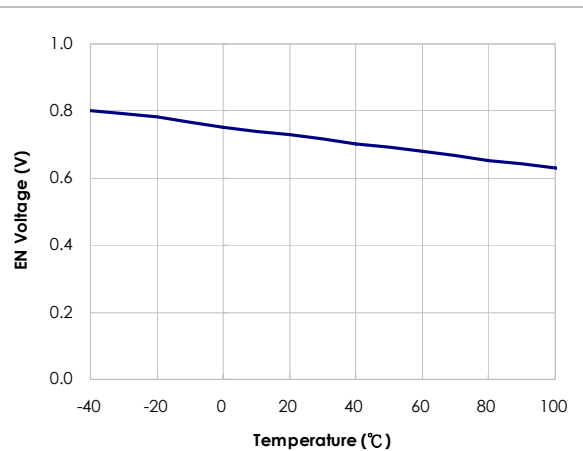

Package Outline Drawing
SOT-23-5

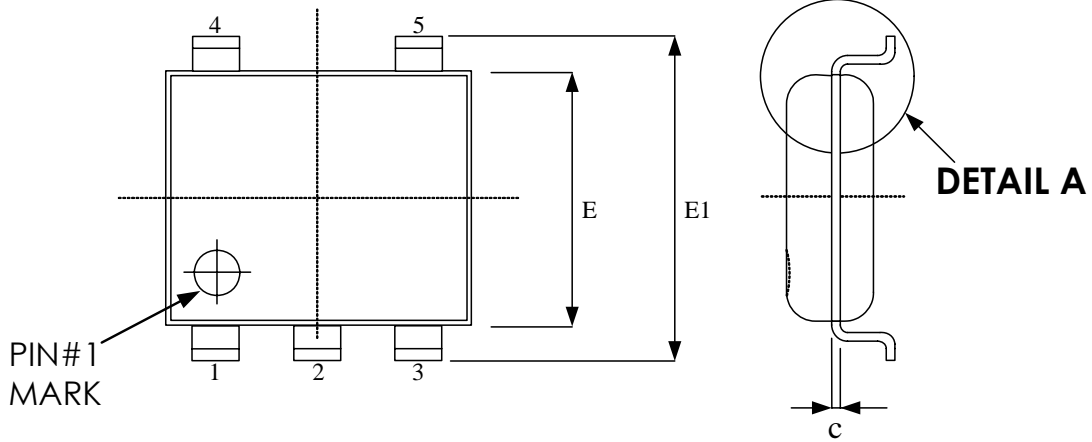

TOP VIEW

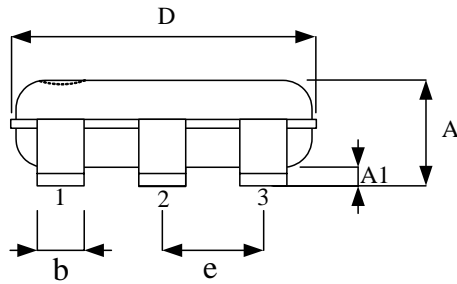

SIDE VIEW

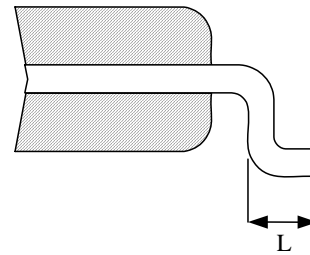

DETAIL A

Symbol	Dimension in mm	
	Min.	Max.
A	0.90	1.45
A1	0.00	0.15
b	0.30	0.50
c	0.08	0.25
D	2.70	3.10
E	1.40	1.80
E1	2.60	3.00
e	0.95 BSC	
L	0.30	0.60

Revision History

Revision	Date	Description
0.1	2016.02.26	Initial version.
0.2	2016.04.15	1. Updated the Fig.1 description. 2. Updated the AMR description. 3. Updated the electrical characteristics table.
1.0	2016.09.01	1. Remove preliminary word and modify version to 1.0 2. Modify order information

Important Notice

All rights reserved.

No part of this document may be reproduced or duplicated in any form or by any means without the prior permission of ESMT.

The contents contained in this document are believed to be accurate at the time of publication. ESMT assumes no responsibility for any error in this document, and reserves the right to change the products or specification in this document without notice.

The information contained herein is presented only as a guide or examples for the application of our products. No responsibility is assumed by ESMT for any infringement of patents, copyrights, or other intellectual property rights of third parties which may result from its use. No license, either express, implied or otherwise, is granted under any patents, copyrights or other intellectual property rights of ESMT or others.

Any semiconductor devices may have inherently a certain rate of failure. To minimize risks associated with customer's application, adequate design and operating safeguards against injury, damage, or loss from such failure, should be provided by the customer when making application designs.

ESMT's products are not authorized for use in critical applications such as, but not limited to, life support devices or system, where failure or abnormal operation may directly affect human lives or cause physical injury or property damage. If products described here are to be used for such kinds of application, purchaser must do its own quality assurance testing appropriate to such applications.