

# YAMAHA

## CD CHANGER RECEIVER AMPLI-TUNER CD CHANGEUR

# EMX-100RDS

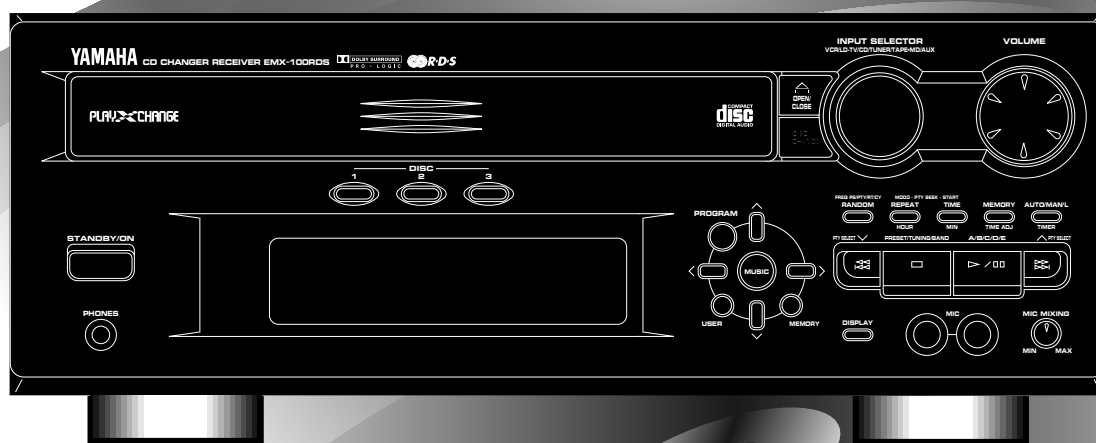

OWNER'S MANUAL  
 MODE D'EMPLOI  
 BEDIENUNGSANLEITUNG  
 BRUKSANVISNING  
 MANUALE DI ISTRUZIONI  
 MANUAL DE INSTRUCCIONES  
 GEBRUIKSAANWIJZING

**SUPPLIED ACCESSORIES**  
**ACCESSOIRES FOURNIS**  
**MITGELIEFERTES ZUBEHÖR**  
**MEDFÖLJANDE TILLBEHÖR**  
**ACCESSORI IN DOTAZIONE**  
**ACCESORIOS INCLUIDOS**  
**BIJGELEVERDE ACCESSOIRES**

- After unpacking, check that the following parts are contained.
- Après le déballage, vérifier que les pièces suivantes sont incluses.
- Nach dem Auspacken überprüfen, ob die folgenden Teile vorhanden sind.
- Kontrollera efter det apparaten packats upp att följande delar finns med.
- Verificare che tutte le parti seguenti siano contenute nell'imballaggio dell'apparecchio.
- Desembalar el aparato y verificar que los siguientes accesorios están en la caja.
- Controleer na het uitpakken of de volgende onderdelen voorhanden zijn.

- Remote control transmitter
- Télécommande
- Fernbedienung
- Fjärrkontroll
- Telecomando
- Transmisor del control remoto
- Afstandbediening

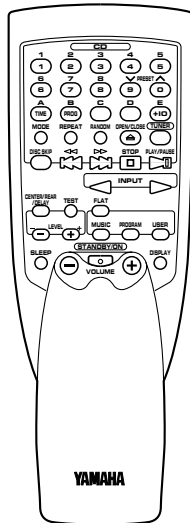

- AM (MW/LW) loop antenna
- Cadre-antenne AM (MW/LW)
- MW/LW-Rahmenantenne
- MV/LV ramantenn
- Antenna circolare per AM (MW e LW)
- Antena de cuadro AM (OM/OL)
- AM (MW/LW) lusantenne

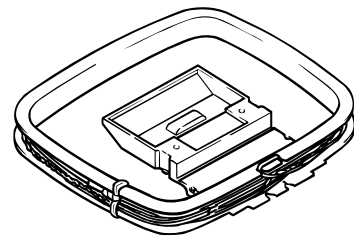

- Batteries (size AA, UM/SUM-3, R6, HP-7)
- Piles (format AA, UM/SUM-3, R6, HP-7)
- Batterien (Größe AA, UM/SUM-3, R6, HP-7)
- Batterier (Storl. AA, UM/SUM-3, R6, HP-7)
- Batterie (dimensioni AA, o UM/SUM-3, o R6, o HP-7)
- Pilas (tamaño AA, tipo UM/SUM-3, R6, HP-7)
- Batterijen (maat AA, UM/SUM-3, R6, HP-7)

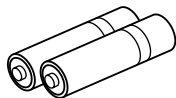

- Indoor FM antenna
- Antenne intérieure FM
- UKW-Innenantenne
- FM inomhusantenn
- Antenna FM per interni
- Antena interior de FM
- FM binnenantenne

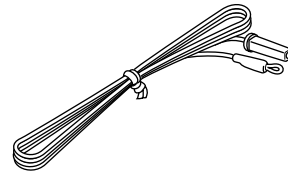

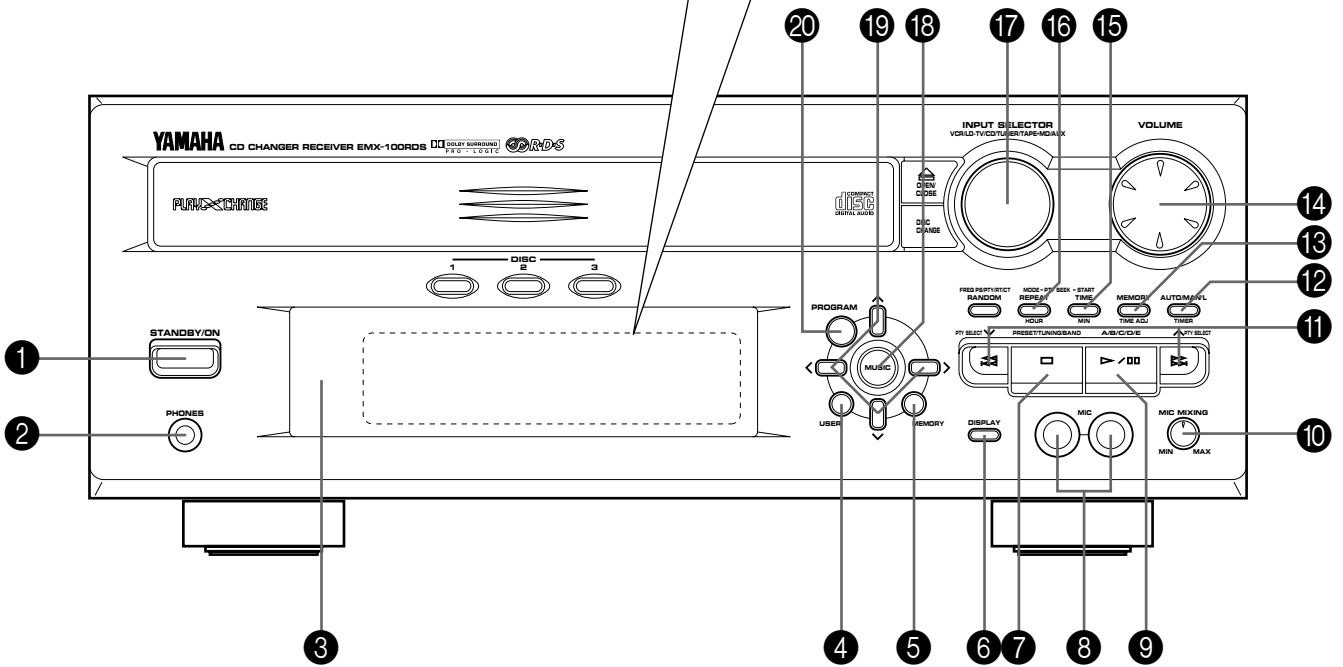
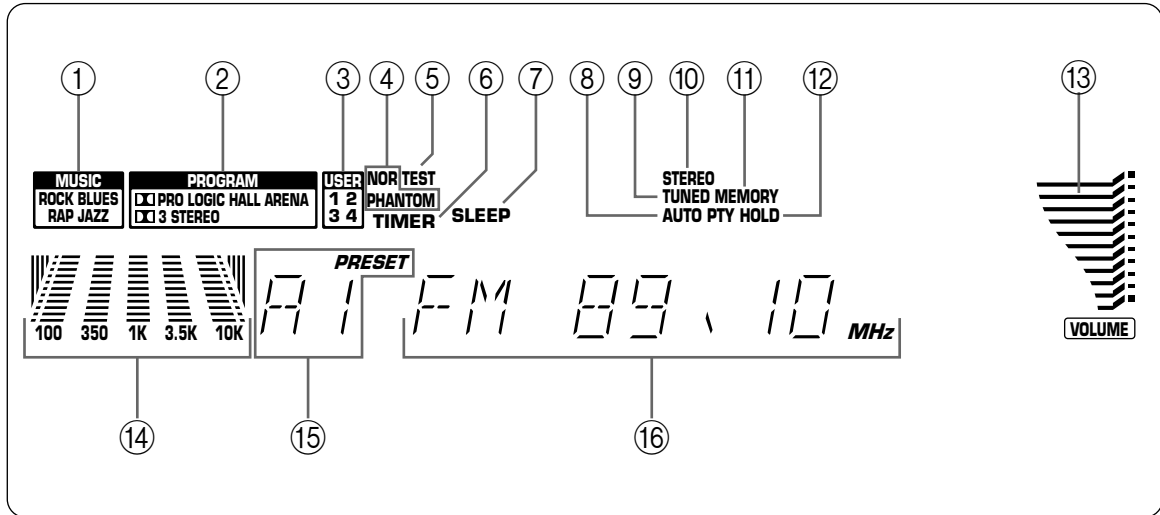

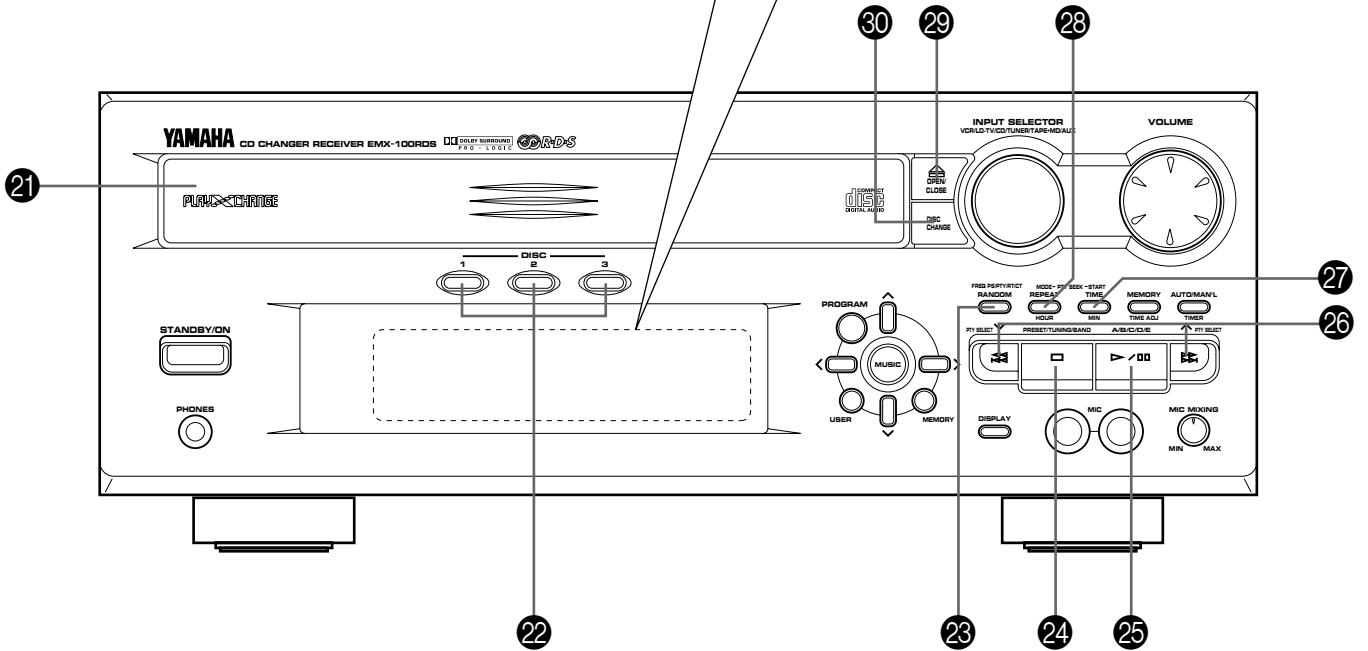
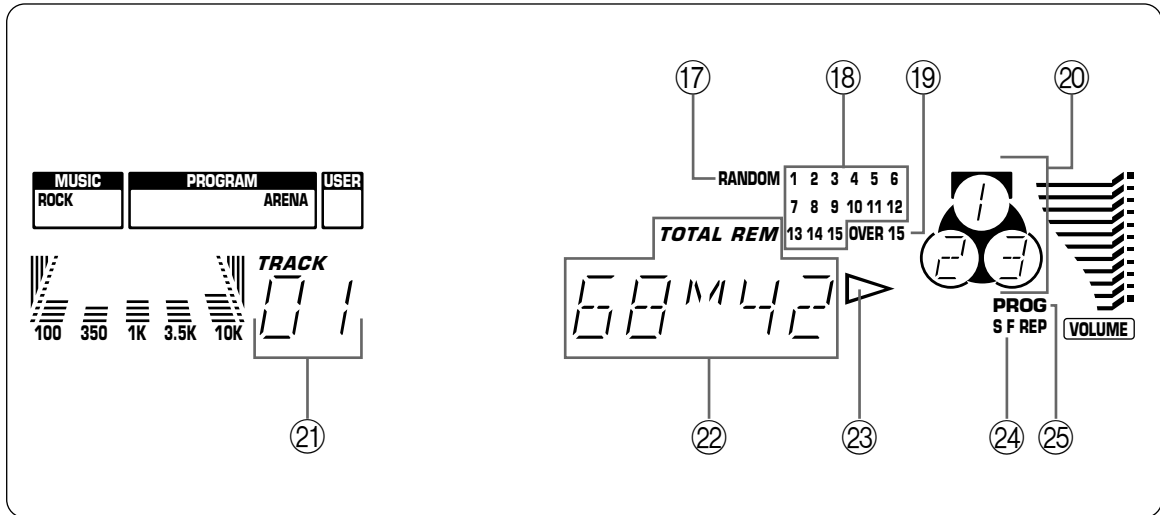

3

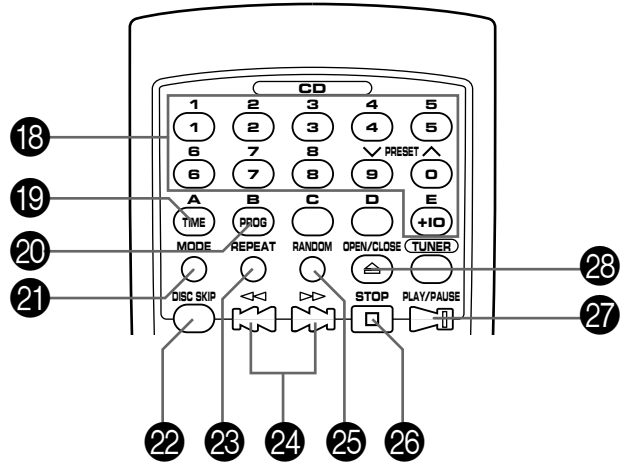
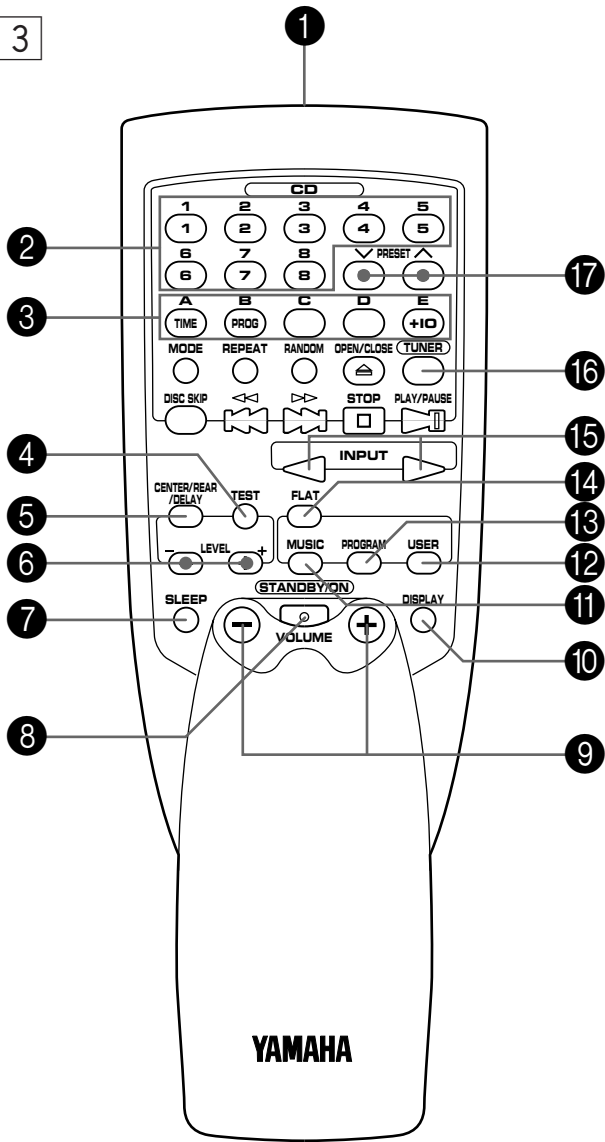

4

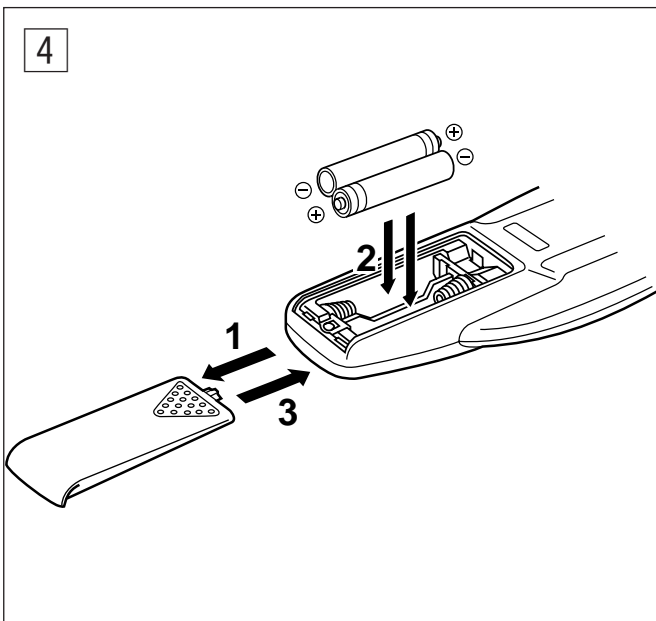

5

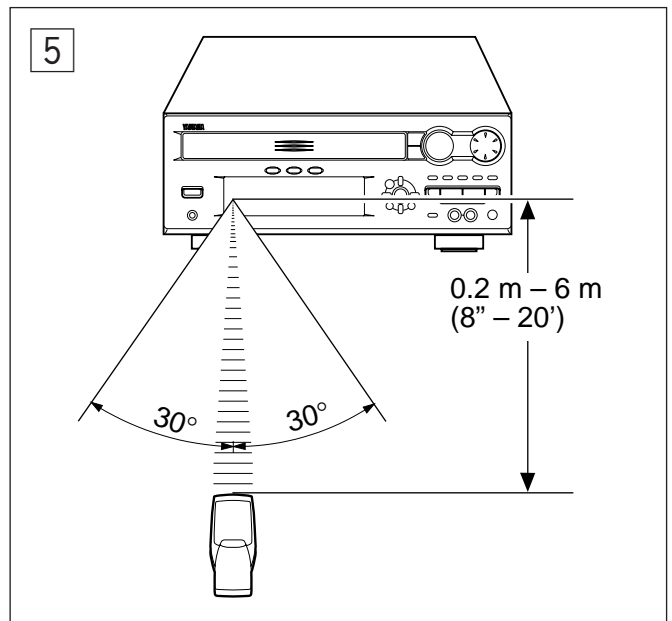

Rear speakers  
 Enceintes arrière  
 hinteres Lautsprecherpaar  
 Bakre högtalare  
 Altoparlanti posteriori  
 Altavoces traseros  
 Achterluidsprekers

Center speaker  
 Enceinte centrale  
 mittlerer Lautsprecher  
 Mitthögtalare  
 Altoparlante centrale  
 Altavoz central  
 Middenluidspreker

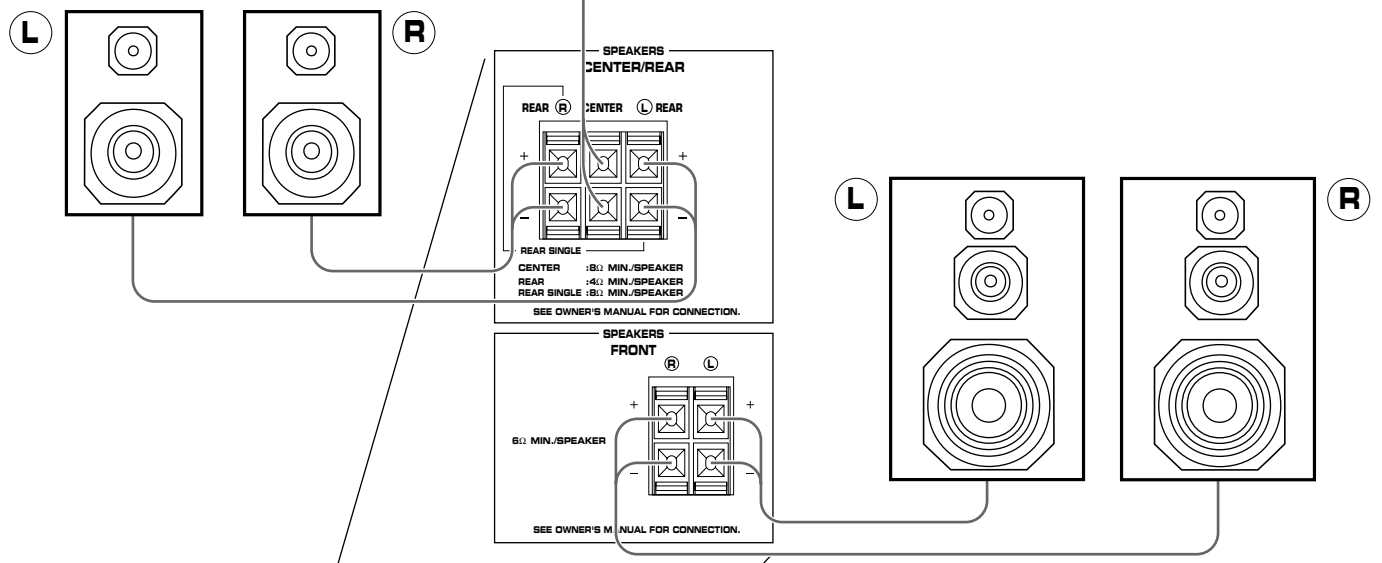

Front speakers  
 Enceintes avant  
 vorderes Lautsprecherpaar  
 Främre högtalare  
 Altoparlanti anteriori  
 Altavoces delanteros  
 Voorluidsprekers

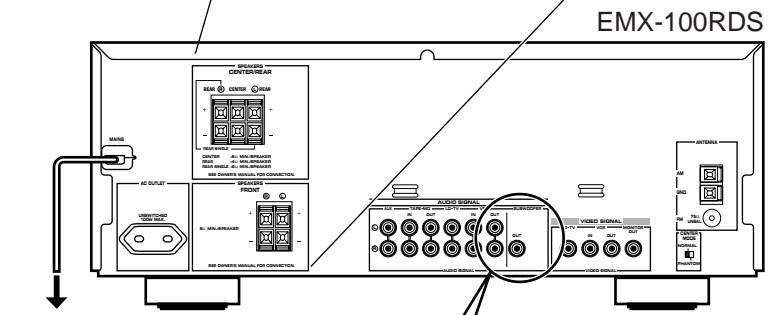

To AC outlet  
 Vers la prise CA  
 Zur Netzsteckdose  
 Till nätuttag  
 Alla presa AC  
 Al tomacorriente  
 Naar wisselstroom-  
 stopcontact

Subwoofer system  
 Subwoofer de Traitement  
 Subwoofer  
 Subwoofer-högtalare  
 Sistema Subwoofer  
 Sistema de altavoz de graves  
 secundarios  
 Subwoofer systeem

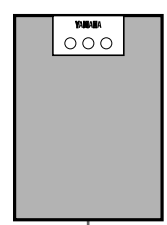
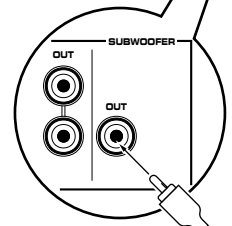

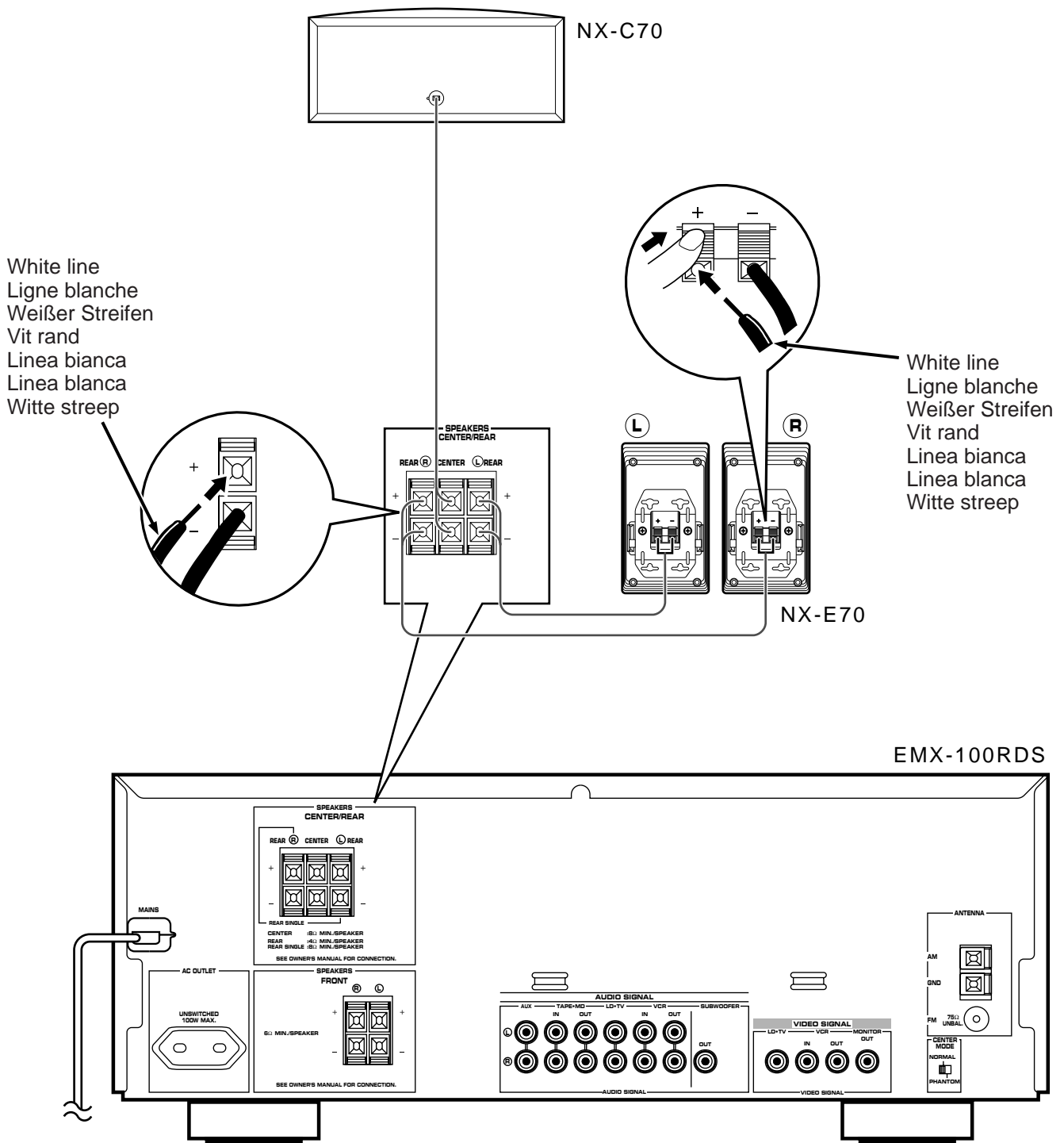

LD player etc.  
 Lecteur de disque laser, etc.  
 LD-Spieler, usw.  
 LD-spelare etc.  
 Lettore per videodischi, ecc.  
 Tocadiscos de discos láser, etc.  
 LD speler, enz.

Monitor TV  
 Moniteur TV  
 Fernsehmonitor  
 TV-monitor  
 Monitor TV  
 Monitor de TV  
 Monitor TV

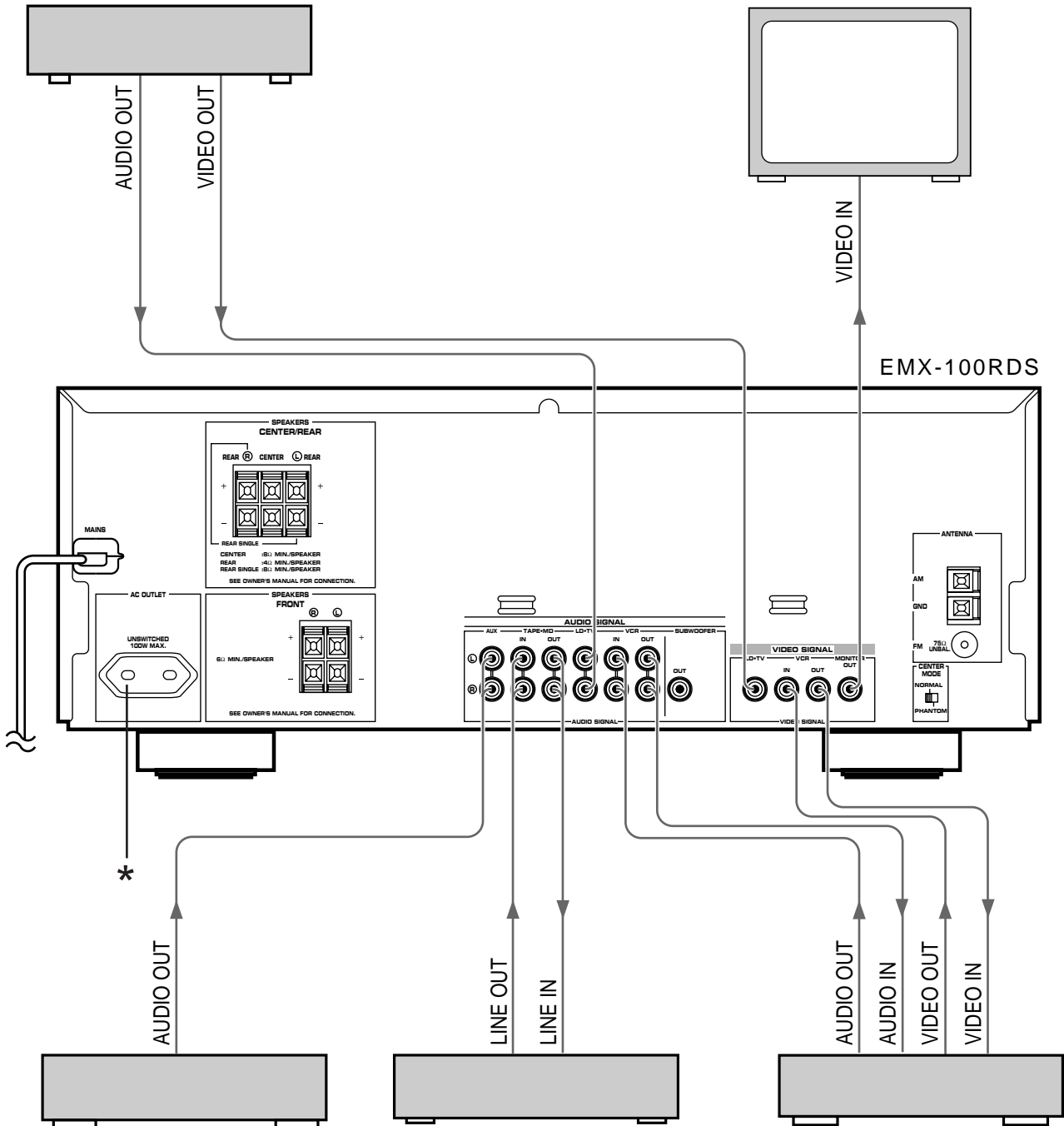

Tape deck, etc.  
 Platine à cassette, etc.  
 Kassettendeck, usw.  
 Kassettdäck, etc.  
 Registratore, ecc..  
 Platina, etc.  
 Tapedeck, enz.

Tape deck, MD recorder, etc.  
 Platine à cassette, magnetophone à minidisque, etc.  
 Kassettendeck, MD-Recorder, usw.  
 Kassettdäck, MD-spelare, etc.  
 Registratore, registratore MD, ecc.  
 Platina, grabador de MD, etc.  
 Tapedeck, MD recorder, enz.

Video cassette recorder  
 Magnétoscope  
 Videocassettenrecorder  
 Videobandspelare  
 Videoregistratore  
 Videograbador  
 Videorecorder



# ENGLISH

## INTRODUCTION

Thank you for purchasing this YAMAHA product. We hope it will give you many years of trouble-free enjoyment. For the best performance, read this manual carefully. It will guide you in operating your YAMAHA product.

## CONTENTS

	Page		Page
PRECAUTIONS.....	2-3	TUNING OPERATION .....	23-25
FEATURES .....	4	RECEIVING RDS STATIONS .....	26-29
NAMES OF CONTROLS AND INDICATORS .....	5	OPERATING EXTERNAL UNITS CONNECTED WITH THIS UNIT.....	30
REMOTE CONTROL TRANSMITTER .....	6	USING GRAPHIC EQUALIZER .....	31-32
SETTING UP THE SPEAKERS .....	7-9	USING SOUND FIELD PROCESSOR .....	33-36
CONNECTIONS .....	10-12	STORING YOUR OWN PROGRAMS .....	37
TURNING THIS UNIT ON OR INTO THE STANDBY MODE .....	12	SINGING KARAOKE BY USING MICROPHONES.....	38
SETTING THE CLOCK.....	13	LISTENING WITH HEADPHONES .....	38
ADJUSTING BRIGHTNESS OF THE DISPLAY.....	13	HOW TO USE THE BUILT-IN TIMER .....	39-41
VOLUME CONTROL .....	13	TROUBLESHOOTING .....	42-43
SPEAKER BALANCE ADJUSTMENT .....	14-15	SPECIFICATIONS .....	44
COMPACT DISC PLAYER OPERATION.....	16-22		

For basic source play, the following illustrations on top of pages will help you to look for the section you need.



.....CD playback



.....Tuning

## PRECAUTIONS: READ THIS BEFORE OPERATING YOUR UNIT

- To assure the finest performance, please read this manual carefully. Keep it in a safe place for future reference.
- Choose the installation location of this unit carefully. Avoid placing it in direct sunlight or close to a source of heat. Also avoid locations subject to vibration and excessive dust, heat, cold or moisture. Keep it away from sources of hum such as transformers and electric motors.
- Do not operate this unit upside-down. It may overheat, possibly causing damage.
- Never open the cabinet. If something drops into the set, contact your dealer.
- The openings on the cabinet assure proper ventilation of the unit. If these openings are obstructed, the temperature inside the cabinet will rise rapidly. Therefore, avoid placing objects against these openings, and install the unit in well-ventilated condition. Be sure to allow a space of at least 20 cm behind, 20 cm on the both sides and 30 cm above the top panel of the unit. Otherwise it may not only damage the unit, but also cause fire.
- Always set the VOLUME control to minimum before starting an audio source play: increase the volume gradually to an appropriate level after play has started.
- When not planning to use this unit for long periods of time (ie., vacation, etc.), disconnect the AC power plug from the wall outlet.
- Grounding or polarization – Precautions should be taken so that the grounding or polarization of the unit is not defeated.
- Do not use force on switches, controls or connection wires. When moving the unit, first disconnect the power plug and the wires connected to other equipment. Never pull the wire itself.
- If an external appliance (TV, radio, etc.) interferes with this unit's operation, move this unit away from such an appliance.
- Do not attempt to clean the unit with chemical solvents; this might damage the finish. Use a clean, dry cloth.
- Be sure to read the "TROUBLESHOOTING" section regarding common operating errors before concluding that the unit is faulty.
- To prevent lightning damage, disconnect the AC power plug and the antenna cable when there is an electrical storm.
- Do not connect audio equipment to the AC outlet on the rear panel if the equipment requires more power than the outlet is rated to provide.
- Do not plug the AC power plug to the wall socket before you finish all connections.
- The voltage to be used must be the same as that specified on this unit. Using this unit with a higher voltage than specified is dangerous and may result in a fire or other types of accidents causing damage. YAMAHA will not be held responsible for any damage resulting from use of this unit with a voltage other than specified.
- The sound level at a given volume setting depends on speaker location and other factors. Care should be taken to avoid exposure to sudden high levels of sound, which may occur when turning on the unit with the volume control setting at high, and to continuous high levels of sound.
- Sudden temperature changes and storage or operation in an extremely humid environment may cause condensation inside the cabinet. Condensation can cause the unit to malfunction.

To eliminate condensation:

  - **CD pickup**  
Leave the power on with no disc in the unit until normal playback is possible (about 1 hour).
  - **Remote control**  
Wipe off condensation on the transmitter window with a soft cloth before operating the unit.

## PRECAUTIONS: READ THIS BEFORE OPERATING YOUR UNIT

### IMPORTANT

Please record the serial number of this unit in the space below.

Model:

Serial No.:

The serial number is located on the rear of the unit. Retain this Owner's Manual in a safe place for future reference.

### WARNING

TO REDUCE THE RISK OF FIRE OR ELECTRIC SHOCK, DO NOT EXPOSE THIS APPLIANCE TO RAIN OR MOISTURE.

### NOTE

Please check the copyright laws in your country to record from records, compact discs, radio, etc. Recording of copyright material may infringe copyright laws.

### For U.K. customers

If the socket outlets in the home are not suitable for the plug supplied with this appliance, it should be cut off and an appropriate 3 pin plug fitted. For details, refer to the instructions described below.

**Note:** The plug severed from the mains lead must be destroyed, as a plug with bared flexible cord is hazardous if engaged in a live socket outlet.

### SPECIAL INSTRUCTIONS FOR U.K. MODEL

#### IMPORTANT:

THE WIRES IN MAINS LEAD ARE COLOURED IN ACCORDANCE WITH THE FOLLOWING CODE:

Blue: NEUTRAL

Brown: LIVE

As the colours of the wires in the mains lead of this apparatus may not correspond with the coloured markings identifying the terminals in your plug, proceed as follows: The wire which is coloured BLUE must be connected to the terminal which is marked with the letter N or coloured BLACK. The wire which is coloured BROWN must be connected to the terminal which is marked with the letter L or coloured RED. Making sure that neither core is connected to the earth terminal of the three pin plug.

#### CAUTION FOR CARRYING THIS UNIT

Be sure not to carry or tip this unit with discs remaining in it.

#### CAUTION FOR MOVING THIS UNIT

Before moving this unit, first remove all discs from the disc table and close the table by pressing the OPEN/CLOSE button. After you confirm that "NO DISC" lights up on the display, turn this unit into the standby mode by pressing the STANDBY/ON switch, and then disconnect the power plug from the AC outlet.

This unit is not disconnected from the AC power source as long as it is connected to the wall outlet, even if this unit itself is turned off. This state is called the standby mode.

In this state, this unit is designed to consume a certain level of power.

### WARNING

To reduce the risk of fire or electric shock, do not expose this unit to rain or moisture.

To avoid electrical shock, do not open the cabinet. Refer servicing to qualified personnel only.

#### CAUTION 1

Use of controls or adjustments or performance of procedures other than those specified herein may result in hazardous radiation exposure.

#### CAUTION 2

As the laser beam used in this unit is harmful to the eyes, do not attempt to disassemble the cabinet. Refer servicing to qualified personnel only.

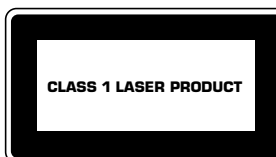

This unit is classified as a CLASS 1 LASER product. The CLASS 1 LASER PRODUCT label is located on the rear exterior.

Laser component in this product is capable of emitting radiation exceeding the limit for Class 1.

#### Laser Diode Properties

- Material: GaAlAs
- Wavelength: 780nm
- Emission Duration: continuous
- Laser Output: max. 44.6μW\*

\* This output is the value measured at a distance of about 200mm from the objective lens surface on the Optical Pick-up Block.

## FEATURES

### General

- **5-Speaker Configuration**
  - Front L, R: 65W + 65W (6 $\Omega$ ) RMS Output Power, 1% THD, 1 kHz
  - Center: 25W (6 $\Omega$ ) RMS Output Power, 1% THD, 1 kHz
  - Rear: 20W (8 $\Omega$ ) RMS Output Power, 1% THD, 1 kHz
- **Adjustable Display Brightness**
- **2 Microphone Jacks and Mic Mixing Level Control**
- **Multi-use Timer/Sleep Timer**
- **Automatic Turning This Unit into the Standby Mode**
- **5 External Audio/Video Component Connecting Capability**
- **SUBWOOFER Output Terminal which Passes Low Frequencies Only**
- **Remote Control Capability**

### Compact Disc Player

- **3-Disc Carousel Type CD Changer**
- **PLAYXCHANGE; Disc Changing Capability while Playing Back Another**
- **20-Track Random Access Programmable CD Playback**
- **Single Track/Entire Disc/All Disc Repeat Play**
- **Random-sequence Play**

### Tuner

- **40 Station Random Access Preset Tuning**
- **40 Station Automatic Preset Tuning**
- **Multi-functions for RDS Broadcast Reception**

### Sound Field Processor Including Dolby Pro Logic Surround Decoder

- **2 Programs for Dolby Surround Decoding (DOLBY PRO LOGIC and DOLBY 3 STEREO)**  
**2 Programs for Sound Field Processing (HALL and ARENA)**
- **Automatic Input Balance Control for Dolby Pro Logic Surround**
- **2 Center Channel Modes (NORMAL/PHANTOM)**
- **Test Tone Generator for Easier Speaker Balance Adjustment**

### Graphic Equalizer

- **5-Band Adjustable Graphic Equalizer**
- **4 Preset Graphic Equalizer Modes Selectable According to the Music Source (ROCK, BLUES, RAP and JAZZ)**
- **4 Sound Field and 4 Equalizer Control Mode Storing Capability**

## Dolby Pro Logic Surround

This unit employs a Dolby Pro Logic Surround decoder similar to professional Dolby Stereo decoders used in many movie theaters. By using the Dolby Pro Logic Surround decoder, you can experience the dramatic realism and impact of Dolby Surround movie theater sound in your own home. Dolby Pro Logic employs a four-channel-five-speaker system. The Pro Logic Surround system divides the input signal into four levels: the left and right main channels, the center channel (used for dialog), and the rear surround sound channels (used for sound effects, background noise, and other ambient noises). The center channel allows listeners seated in even less-than-ideal positions to hear the dialog originating from the action on the screen while experiencing good stereo imaging.

Dolby Surround is encoded on the sound track of pre-recorded video tapes, laser discs, and some TV/cable broadcasts. When you play a source encoded with Dolby Surround on this unit, the Dolby Pro Logic Surround decoder decodes the signal and distributes the surround-sound effects.

In addition, this unit features a built-in automatic input balance control. This always assures you the best performance without manual adjustment.

Manufactured under license from Dolby Laboratories Licensing Corporation. DOLBY, the double-D symbol and "PRO LOGIC" are trademarks of Dolby Laboratories Licensing Corporation.

## NAMES OF CONTROLS AND INDICATORS

### For amplifier/tuner

(See figure 1 on page 3 at the beginning part of this manual.)

#### Display

- ① Preset Equalizer Mode Indicator (**MUSIC**)
- ② Sound Field Program Indicator (**PROGRAM**)
- ③ User Program Number Indicator (**USER**)
- ④ Center Channel Mode (**NOR/PHANTOM**) Indicator
- ⑤ **TEST** Indicator
- ⑥ **TIMER** Set Indicator
- ⑦ **SLEEP** Indicator
- ⑧ **AUTO** Tuning Indicator
- ⑨ **TUNED** Indicator
- ⑩ **STEREO** Indicator
- ⑪ **MEMORY** Indicator
- ⑫ **PTY HOLD** Indicator
- ⑬ Volume Level Meter (**VOLUME**)
- ⑭ Graphic Equalizer Level Indicators
- ⑮ Preset Number Indicator (**PRESET**)
- ⑯ Multi Information Display  
(Time, Station Frequency, Volume Level, etc.)

- ① **STANDBY/ON** Switch
- ② **PHONES** Jack
- ③ Remote Control Sensor
- ④ **USER** Button
- ⑤ User Program **MEMORY** Button
- ⑥ **DISPLAY** Button
- ⑦ **PRESET/TUNING/BAND** Selector Button
- ⑧ **MIC** (Microphone) Jacks
- ⑨ **A/B/C/D/E** Button
- ⑩ **MIC MIXING** (Microphone Mixing) Level Control
- ⑪ **(PTY SELECT)** ∨ (Down)/ ^ (Up) Buttons
- ⑫ **AUTO/MAN'L (TIMER)** Button
- ⑬ Tuner **MEMORY (TIME ADJUST)** Button
- ⑭ **VOLUME** Control
- ⑮ **PTY SEEK START (MIN)** Button
- ⑯ **PTY SEEK MODE (HOUR)** Button
- ⑰ **INPUT SELECTOR**
- ⑱ **MUSIC** Button
- ⑲ Equalizer Control Buttons
- ⑳ **PROGRAM** Selector Button

### For CD player

(See figure 2 on page 4 at the beginning part of this manual.)

#### Display

- ⑰ **RANDOM** Play Indicator
- ⑱ Music Calendar Indicator
- ⑲ Music Calendar **OVER 15** Indicator
- ⑳ Disc Indicator
- ㉑ Track Number Indicator (**TRACK**)
- ㉒ Time Display
- ㉓ Play Indicator: ▷
- ㉔ **(S, F) REPEAT** Indicator
- ㉕ Program (**PROG**) Play Indicator

- ㉑ Disc Table
- ㉒ **DISC** Selector Buttons
- ㉓ **RANDOM** Button
- ㉔ Stop Button: □
- ㉕ Play/Pause Button: ▷/⏸
- ㉖ Skip Buttons: ◀◀/▶▶  
(Search Buttons: ◀◀/▶▶)
- ㉗ **TIME** Button
- ㉘ **REPEAT** Button
- ㉙ **OPEN/CLOSE** Button: △
- ㉚ **DISC CHANGE** Button

## REMOTE CONTROL TRANSMITTER

### Names of control buttons

(See figure 3 on page 5 at the beginning part of this manual.)

#### ■ Amplifier/tuner control buttons

- 1 Remote Control Transmitter Window
- 2 Preset Station Number Buttons
- 3 A, B, C, D, E Selector Buttons
- 4 TEST Button
- 5 CENTER/REAR/DELAY Selector Button
- 6 LEVEL Control Buttons
- 7 SLEEP Button
- 8 STANDBY/ON Switch
- 9 VOLUME – (Down)/+ (Up) Buttons
- 10 DISPLAY Button
- 11 MUSIC Button
- 12 USER Button
- 13 PROGRAM Button
- 14 FLAT Button
- 15 INPUT Selector Buttons
- 16 TUNER Input Selector Button
- 17 PRESET Number ∨ (Down)/ ^ (Up) Buttons

#### ■ CD player control buttons

- 18 Track Number Input Buttons
- 19 TIME Button
- 20 PROGRAM Button
- 21 Disc Play MODE Selector Button
- 22 DISC SKIP Button
- 23 REPEAT Button
- 24 Skip Buttons: <</>>  
(Search Buttons: <</>> )
- 25 RANDOM Button
- 26 STOP Button: □
- 27 PLAY/PAUSE Button: ▷ ▢
- 28 OPEN/CLOSE Button: △

### Loading the batteries for the remote control transmitter

(See figure 4 on page 5.)

- 1 Remove the battery compartment cover.  
(Slide the cover in the direction of the arrow.)
- 2 Insert 2 “AA” size batteries (UM/SUM-3, R6, HP-7 or equivalent) into the battery compartment.  
\* Installing the batteries improperly may cause failure.
- 3 Replace the battery compartment cover.

#### Precautions for battery use

- Insert the batteries according to the direction indicated in the battery compartment.
- Replace all batteries with new ones at the same time.
- Remove the batteries if they are weak or the unit is not in use for long periods.
- Don't mix normal batteries with rechargeable batteries.

### Proper use of the remote control transmitter

(See figure 5 on page 5.)

Aim (within the range of 60° with no obstacles) the remote control transmitter at the remote control sensor and operate as shown.

#### Notes concerning use

- Replace the batteries if control distance decreases or operation becomes unstable.
- Periodically clean the transmitter window on the remote control transmitter and the sensor on the main unit with a soft cloth.
- Exposing the sensor on the main unit to strong light (especially an inverter type of fluorescent lamp etc.) may interfere with operation. In this case, reposition the main unit to avoid direct lighting.
- Keep the remote control transmitter away from moisture, excessive heat, shock and vibrations.
- The remote control transmitter's usable range is within 0.2m (8") and 6m (20') away from the sensor.

## SETTING UP THE SPEAKERS

This unit is designed to provide the best sound-field quality with a 5-speaker configuration: a pair of front speakers, a pair of rear speakers and a center speaker. You may omit the center speaker, if, for some reason, it is not practical to use a center speaker. (Refer to the "4-Speaker Configuration" shown below.)

The front speakers are used for the main source sound plus the effect sounds. The rear speakers are used for the effect and surround sounds, and the center speaker is for the center sounds (dialog etc.).

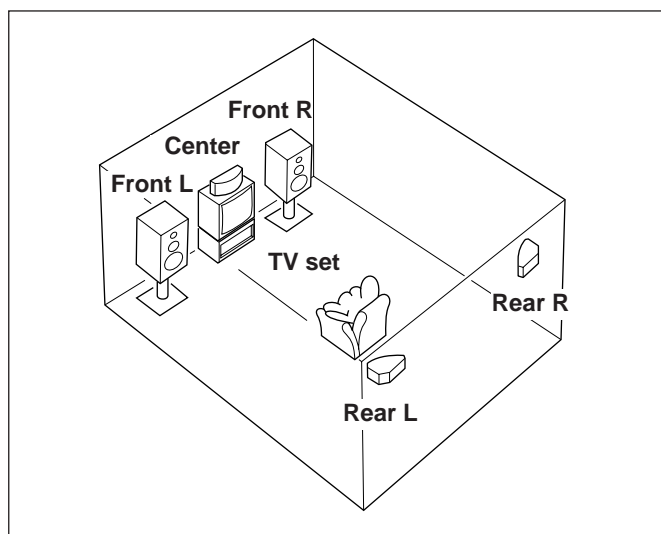
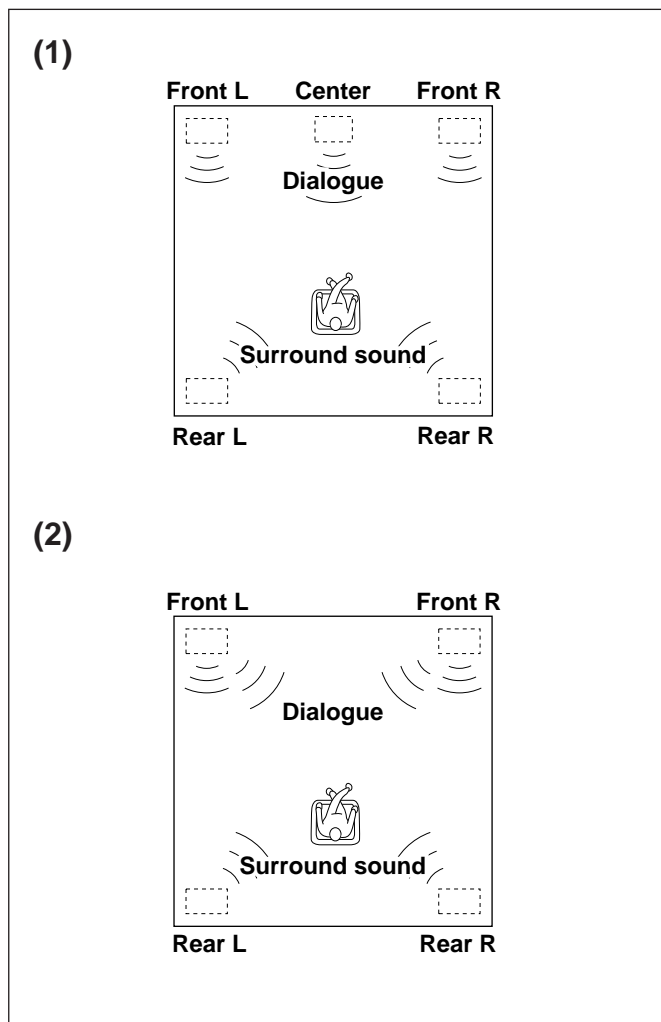

## Speaker configuration

### (1) 5-Speaker Configuration

This configuration is the most effective and recommended one. In this configuration, the center speaker is necessary as well as the rear speakers. If the sound field program **DOLBY PRO LOGIC** or **DOLBY 3 STEREO** is selected, conversations will be output from the center speaker and the ambience will be excellent.

- Set the center channel mode to the "NORMAL" position. (For details, refer to page 14.)

### (2) 4-Speaker Configuration

The center speaker is not used in this configuration. If the sound field program **DOLBY PRO LOGIC** is selected, the center sound is output from the left and the right front speakers, although the program **DOLBY 3 STEREO** is useless in this configuration. However, the sound effect of other programs can be the same as that of the 5-speaker configuration.

- Be sure to set the center channel mode to the "PHANTOM" position. (For details, refer to page 14.)

#### Note

Be sure to use two rear speakers. If you connect one rear speaker only, sound will not be output from the rear speaker.

## Speaker placement

- Front speakers:** In normal position.
- Rear speakers:** Behind your listening position, facing slightly inward. Nearly 1.8 m (approx. six feet) up from the floor.
- Center speaker:** Precisely between the front speakers.

## SETTING UP THE SPEAKERS

1

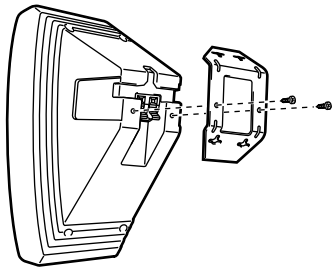

2

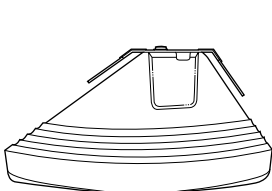
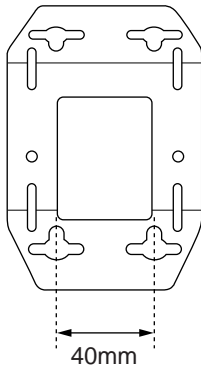
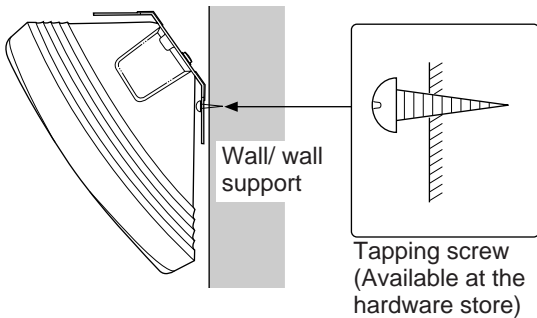

**Good**

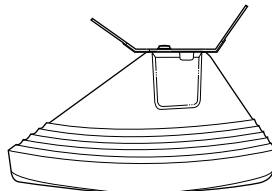

**No good**

### Only for customers who use the YAMAHA NS-P30 speaker system (separate purchase)

If you use the YAMAHA NS-P30 speaker system with this unit, read the following descriptions for mounting the NS-P30.

\* "NS-P30" is the package number which includes the YAMAHA speaker systems NX-E70 and NX-C70. NX-E70 is designed to be used as a rear effect speaker system, and NX-C70 is designed to be used as a center speaker system.

#### ■ Mounting the rear speakers (NX-E70)

Mount the rear speakers on a shelf, rack or on the floor directly, or hang them on the wall.

##### To mount the rear speakers on a wall

- 1 Attach the provided mounting bracket to the rear of the speaker by using the provided screws.
- 2 Fasten screws into a firm wall or wall support as shown in the diagram, and hang the holes of the mounting bracket on the protruding screws.
  - \* The holes are arranged so that the speakers can be mounted in a side long, upright or upside-down way.
  - \* Make sure that the screws are caught by a narrow part of the holes securely.

##### Notes

- Never attach the bracket to the speaker conversely.
- Speaker cords should be connected to the speaker's terminals after the bracket has attached to the speaker to prevent the speaker cords pressed between the speaker and the bracket.



## SETTING UP THE SPEAKERS

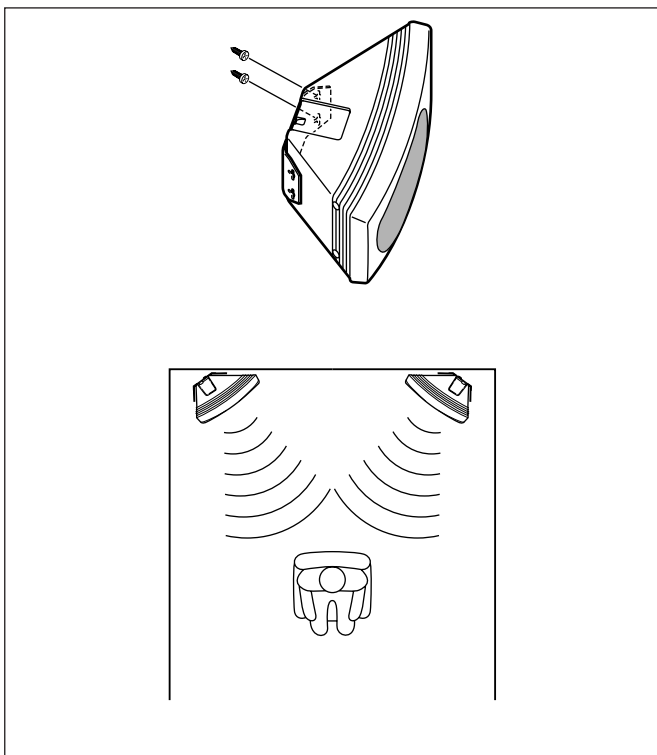

### To hang in a side long way

Hang the speakers so that each of them faces inside as figured left.

### **WARNING:**

- Each speaker weighs 0.8 kg (1 lbs. 12 oz.). Do not mount them on thin plywood or soft wall surface material, as the screws may come out of the flimsy surface, causing the speakers to fall down and be damaged, or result in personal injury.
- Do not fasten the speakers to wall with nails, adhesives, or other unsound hardware. Long-term use and vibrations may cause them to fall down.
- To avoid accidents resulting from tripping over loose speaker cables, fix them to the wall.

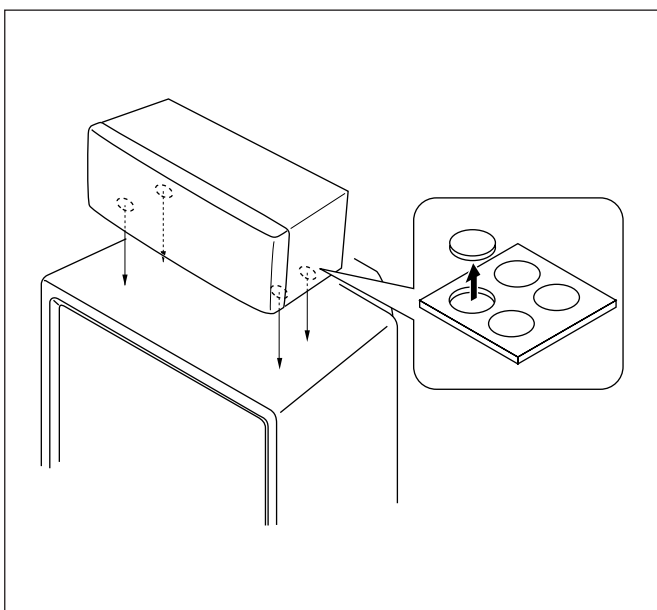

### ■ Mounting the center speaker (NX-C70)

Place the speaker on top of the TV or on the floor under the TV or inside the TV rack so that it is stabilized.

When placing the speaker on top of the TV, to prevent the speaker from falling down, put the provided pads at four points on bottom of the speaker.

### **Notes**

- Do not place the speaker on top of the TV whose area is smaller than the bottom area of the speaker. If placed, the speaker may drop out causing an injury to you.
- Though this speaker is a magnetic shielding type, there may be some influence on a TV picture depending on the type of TV or the placement of the speaker. In such a case, place the speaker apart from the TV so that there is no influence on TV picture.

## CONNECTIONS

Never plug the AC supply lead of this unit into the AC outlet until all connections are completed.

### Connecting speakers

(See figure 6 on page 6.)

Connect the front speakers to the FRONT SPEAKERS terminals, the center speaker to the CENTER SPEAKERS terminals and the rear speakers to the REAR SPEAKERS terminals.

#### Note

Use speakers with the specified impedance shown on the rear of this unit.

#### How to Connect:

Connect the **SPEAKERS** terminals to your speakers with wire of the proper gauge, cut as short as possible. If the connections are faulty, no sound will be heard from the speakers. Make sure that the polarity of the speaker wires is correct, that is the + and – markings are observed. If these wires are reversed, the sound will be unnatural and lack bass.

#### Caution

**Do not let the bare speaker wires touch each other as this could damage the amplifier and/or speakers.**

Red: positive (+)

Black: negative (–)

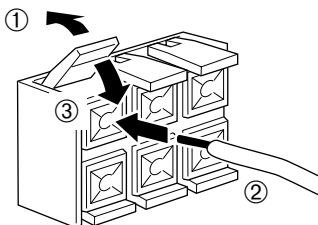

- ① Press up the tab.
- ② Insert the bare wire. [Remove approx. 5mm (1/4") insulation from the speaker wires.]
- ③ Press down the tab and secure the wire.

#### Note on connecting a subwoofer (separate purchase)

You may wish to add a subwoofer to reinforce the bass frequencies.

Connect the SUBWOOFER OUT terminal of the main unit to the INPUT terminal of the subwoofer amplifier, and connect the speaker terminals of the subwoofer amplifier to the subwoofer.

With some subwoofers, including the Yamaha Active Servo Processing Subwoofer System, the amplifier and subwoofer are in the same unit.

\* The SUBWOOFER OUT terminal outputs low frequencies from the front and center channels. (The cut-off frequency of signals output from this terminal is 200 Hz.)

### How to connect the YAMAHA NS-P30 speaker system (separate purchase) to this unit

(See figure 7 on page 7.)

If you connect the YAMAHA NS-P30 speaker system to this unit, read the following descriptions.

#### NX-E70 (Rear speakers)

- Connect the push-type input terminals on the rear of the speakers to the REAR SPEAKERS terminals of this unit with the provided speaker cables.
- One side of the speaker cable has a white line and the other side has no line. Connect the (+) terminals on both this unit and the speakers using the side with a white line. Connect the (–) terminals on both components using the side with no line.
- Connect one speaker to the left (marked L) terminals of this unit, and another speaker to the right (marked R) terminals, making sure not to reverse the polarity (+, –). If one speaker is connected with reversed polarity, the sound will be unnatural and lack bass.

#### Procedures:

- ① Press the tab on the terminal down, as shown in the figure.
- ② Insert the bare speaker wire end properly into the terminal hole. [Remove approx. 5 mm (1/4") insulation from the speaker cable.]
- ③ Remove your finger from the tab to allow it to lock snugly on the cable's wire end.
- ④ Test the security of the connection by tugging lightly on the cable at the terminal.

#### NX-C70 (Center speaker)

To connect the speaker cable from NX-C70 to the CENTER SPEAKERS terminals of this unit, make sure to connect the side with a white line to the (+) terminal and the side with no line to the (–) terminal.

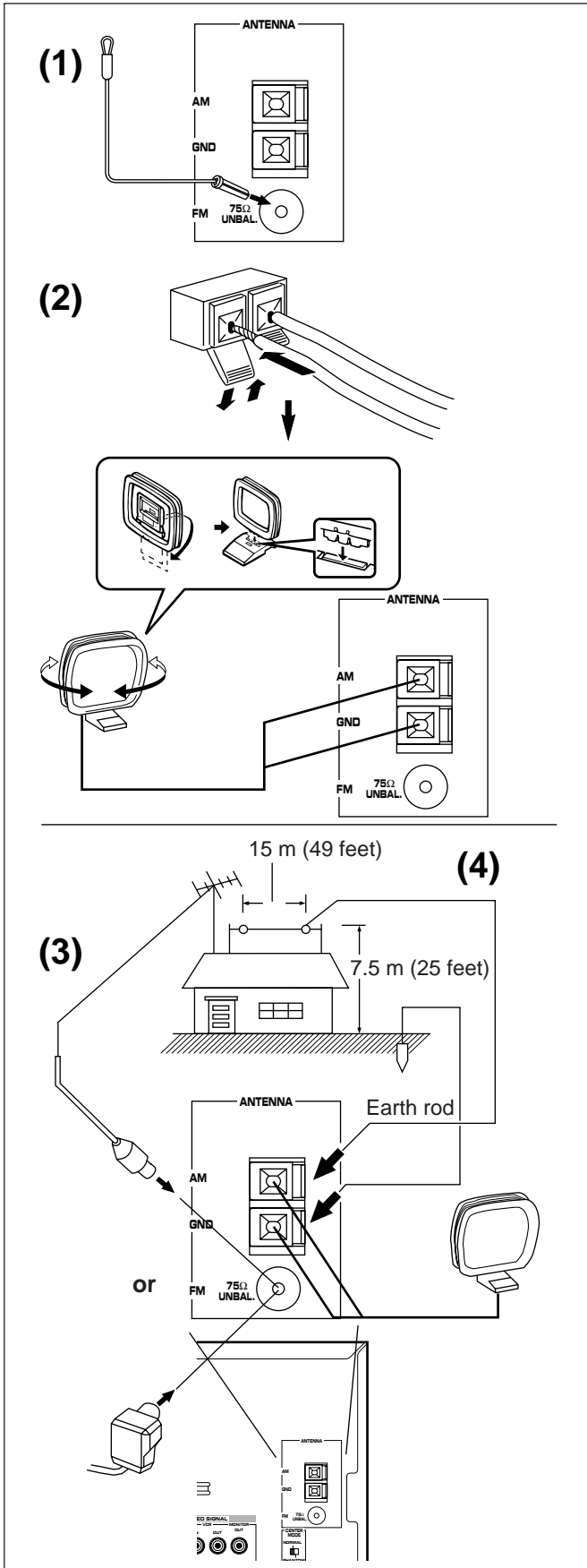

## Antenna connection

### (1) Supplied FM antenna

Connect the FM antenna wire to the corresponding terminal and direct the FM antenna wire to the direction where the strongest signal can be received.

### (2) Supplied AM (MW/LW) loop antenna

Connect the AM (MW/LW) loop antenna wires to the corresponding terminals. Position the AM (MW/LW) loop antenna for optimum reception. Place the AM (MW/LW) loop antenna on a shelf etc., or install it on the rack or wall with screws (not supplied).

#### Notes

- When static is still heard even after adjusting the position of the AM (MW/LW) loop antenna, try reversing the wire connections (from the upper terminal to the lower one, and vice versa).
- Do not place the AM (MW/LW) loop antenna on the unit. It will result in noise generation, since the unit is equipped with digital electronics. Place the AM (MW/LW) loop antenna away from the unit.

### (3) External FM antenna

Use an external FM antenna instead of an indoor FM antenna if you need better reception. Consult your dealer.

### (4) External AM (MW/LW) antenna

Use an external AM (MW/LW) antenna if you need better reception. Consult your dealer.

#### Note

When using an external AM (MW/LW) antenna, be sure to keep the wire of the AM (MW/LW) loop antenna connected.

## CONNECTIONS

### Connecting external components

(See figure 8 on page 8.)

This unit can be connected with external audio and video components. Make connections between this unit and other components using RCA pin plug connector cables correctly, that is to say L (left) to L and R (right) to R. Also, refer to the owner's manual for each component to be connected to this unit.

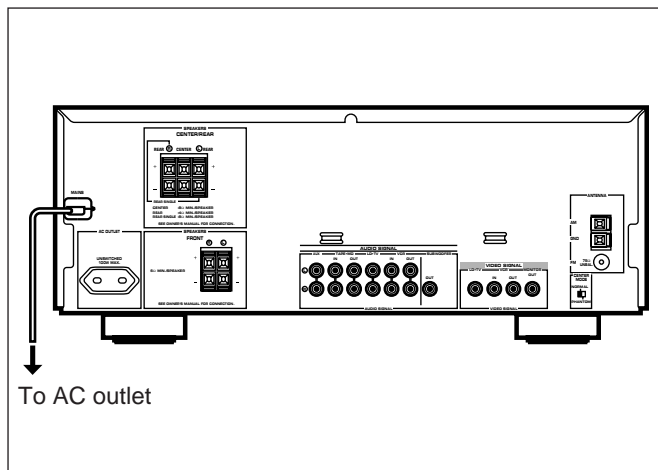

### \* : AC OUTLET (UNSWITCHED)

The power cord of any audio/video unit can be connected to this outlet.

The power to this outlet is not controlled by this unit's STANDBY/ON switch. This outlet will supply power to the connected unit even if this unit is in the standby mode.

The maximum power that can be connected to this outlet is 100 watts

### Connecting the AC supply lead

- After completing all connections, plug the AC supply lead into a convenient AC outlet.
- Unplug the AC supply lead from the AC outlet if the unit is not to be used for a long period of time.

## TURNING THIS UNIT ON OR INTO THE STANDBY MODE

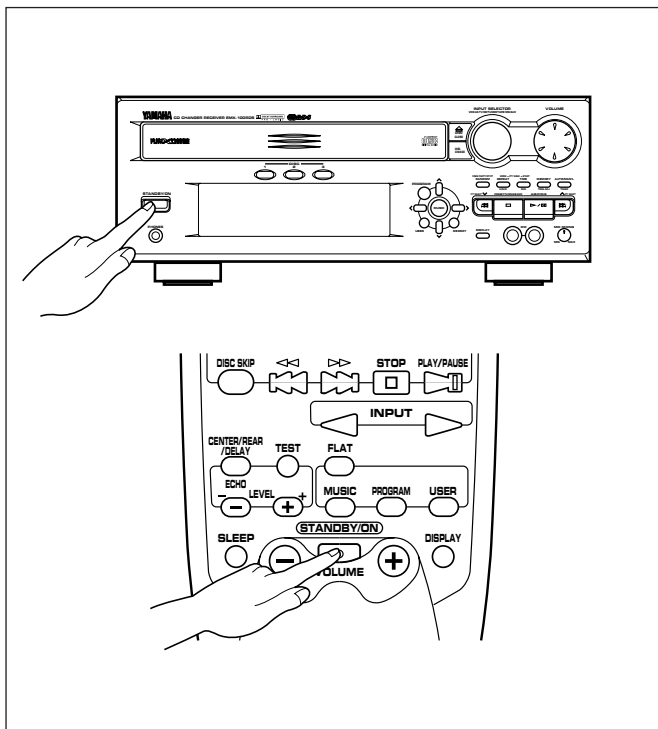

If the AC supply lead is connected to the AC outlet, this unit can be turned on and turned into the standby mode by pressing the STANDBY/ON switch on the front panel of this unit or the STANDBY/ON switch on the remote control transmitter.

### Automatic turning this unit into the standby mode

This unit will be automatically turned into the standby mode if there is no operation on the control parts of this unit, no illumination on the graphic equalizer level indicators and no playback of CD for about 30 minutes.

\* This function is not available unless time setting is made on the built-in clock.

### STANDBY mode

While the power is on, pressing the STANDBY/ON switch (or the STANDBY/ON switch on the remote control transmitter) switches this unit to the standby mode. (In this mode, the display shows only the time.) In this mode, main voltage is still present inside the unit. If you want to switch off this unit completely, disconnect the AC power plug from the AC outlet.

## SETTING THE CLOCK

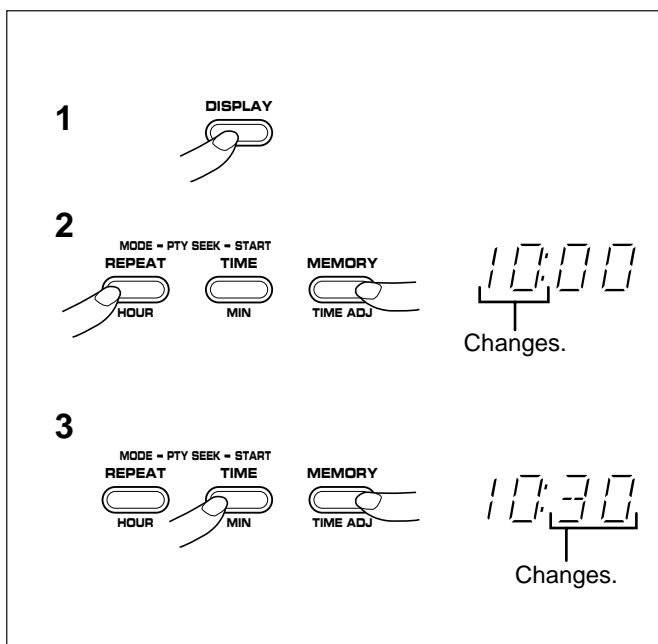

- 1 While the power is on, press the DISPLAY button to display the time. If this unit is in the standby mode, you can proceed to the next step.
- 2 While holding the TIME ADJ button pressed, press the HOUR button and set the hour.
  - \* Press the HOUR button once to advance the time by 1 hour. Press and hold to advance continuously.
- 3 While holding the TIME ADJ button pressed, press the MIN button and set the minute.
  - \* Press the MIN button once to advance the time by 1 minute. Press and hold to advance continuously.

### In the event of a power failure or when the AC supply lead is disconnected.

The time display will go out, however, the clock will function for about 5 minutes without power supply. So you do not have to reset the time if the AC power supply is resumed within about 5 minutes.

When the AC power supply is resumed after more than 5 minutes pass without power supply, the time display will flash on and off to indicate that the time must be reset.

## ADJUSTING BRIGHTNESS OF THE DISPLAY

If desired, you can adjust brightness of the display.

- 1 Press and hold the DISPLAY button for more than 2 seconds so that "DIMMER±0" appears on the display.
- 2 Holding the DISPLAY button pressed, turn the VOLUME control clockwise to increase or counterclockwise to decrease brightness.

This adjustment can be made even though this unit is in the standby mode.

### Control range

When the power is on: ±0 to -6 (Preset value: ±0)

When this unit is in the standby mode : +3 to -3 (Preset value: ±0)

## VOLUME CONTROL

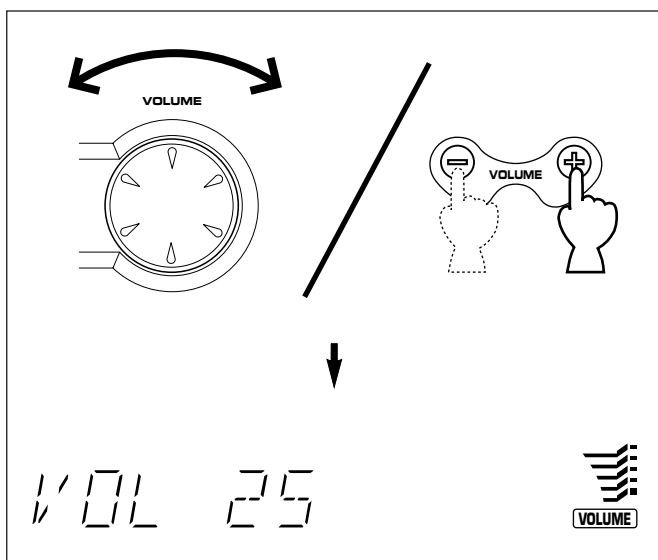

### Front panel operation

Rotate the VOLUME control clockwise to increase the volume, and counterclockwise to decrease the volume.

### Remote control operation

Press the VOLUME + button to increase the volume and the VOLUME - button to decrease the volume.

\* Adjusted volume level is shown by the volume level meter and in figures on the display.

## SPEAKER BALANCE ADJUSTMENT

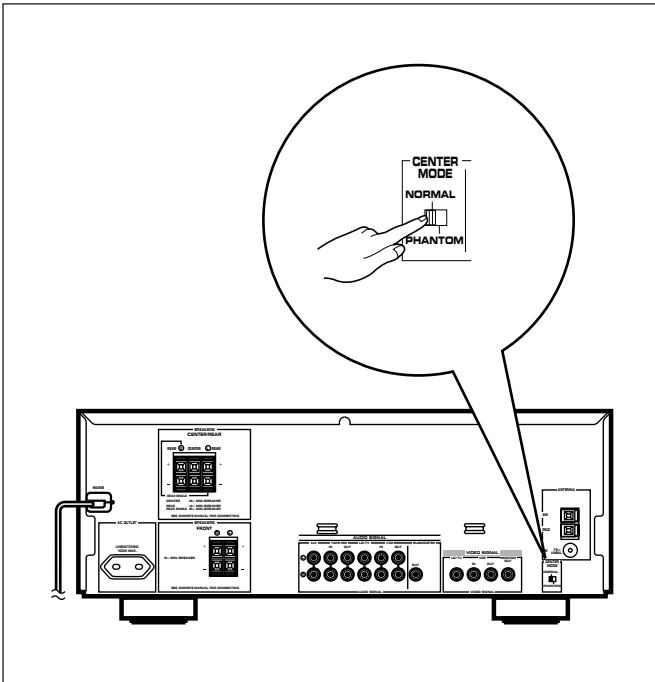

This procedure lets you adjust the sound output level balance between the front, center, and rear speakers using the built-in test tone generator. When this adjustment is performed, the sound output level heard at the listening position will be the same from each speaker. This is important for the best performance of the built-in Dolby Pro Logic surround decoder. **The adjustment of each speaker output level should be done at your listening position with the remote control transmitter. Otherwise, the result may not be satisfactory.**

### Before operation

Set the CENTER MODE switch on the rear panel of this unit to the position suitable for your speaker system configuration. (Refer to page 7 for details.)

#### NORMAL (For 5 speaker configuration):

Select this position when you use the center speaker.

#### PHANTOM (For 4 speaker configuration):

Select this position when you do not use the center speaker. The center sound will be output from the left and right front speakers.

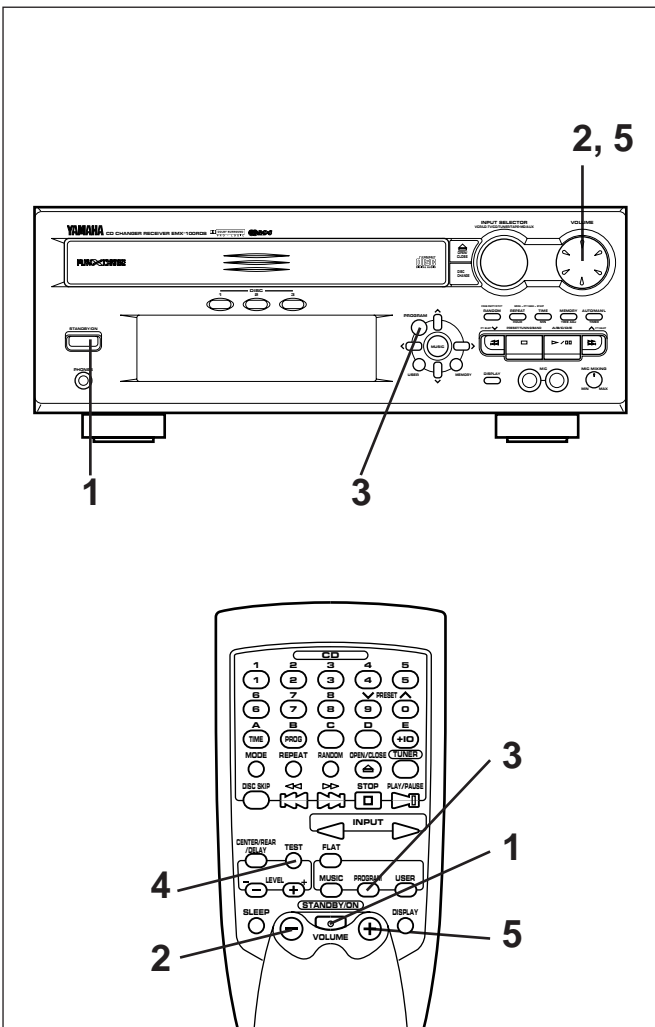

- 1 Press the STANDBY/ON switch to turn the power on.
- 2 Turn the VOLUME control counterclockwise to decrease the volume to minimum.
- 3 Press the PROGRAM button once or more so that "PRO LOGIC" lights up on the sound field program indicator.
- 4 Press the TEST button.  
\* "TEST" flashes on and off on the display.
- 5 Press the VOLUME + (up) button to increase the volume.

You will hear a test tone (like pink noise) from the left front speaker, then the center speaker, then the right front speaker, and then the rear speakers, for about two seconds each. The display changes as shown below.

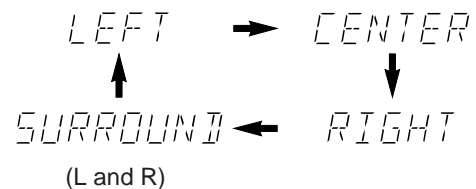

\* The test tone from the left rear speaker and the right rear speaker will be heard at the same time.

## SPEAKER BALANCE ADJUSTMENT

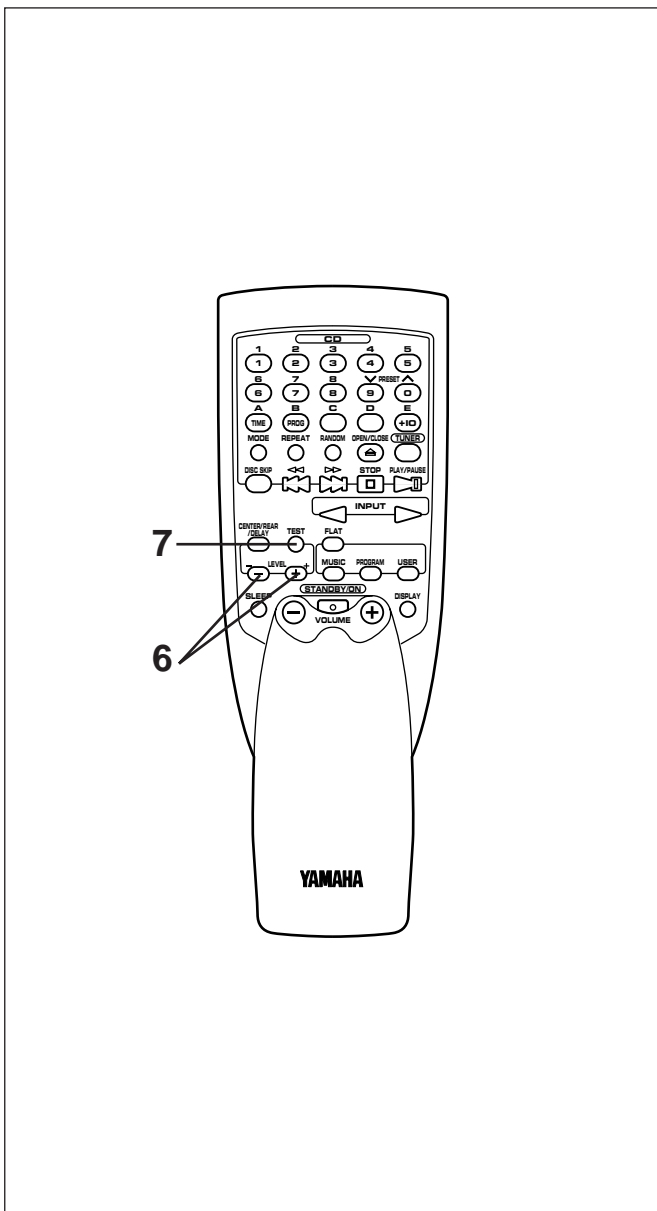

**6** Adjust the sound output levels of the center speaker and the rear speakers by using the LEVEL control buttons so that they become almost as same as that of the front speakers.

- When the test tone is output from the center speaker, pressing the LEVEL control buttons change the output level of the center speaker.

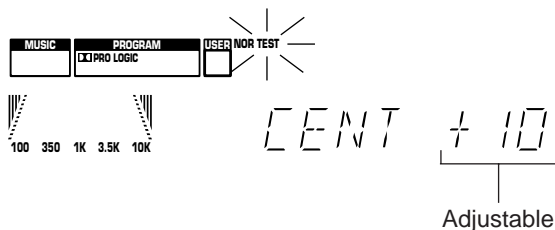

- When the test tone is output from the rear speakers, pressing the LEVEL control buttons change the output level of the rear speakers.

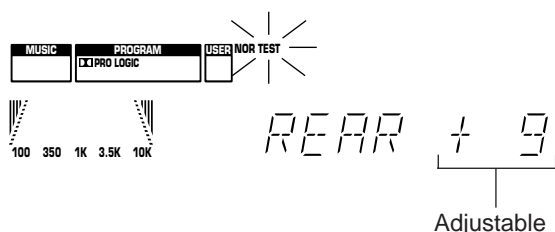

- \* Pressing the + button raises and the – button lowers the level.

**7** If the adjustments are finished, press the TEST button to cancel the test tone.

- \* “TEST” disappears from the display.

### Notes

- Once you have completed these adjustments, you can adjust whole sound level on your audio system by using the VOLUME control (or the VOLUME keys on the remote control transmitter) only.
- In step 6, if the center channel mode is in the “PHANTOM” position, the sound output level of the center speaker cannot be adjusted. This is because in this mode, the center sound is automatically output from the left and right front speakers.



# COMPACT DISC PLAYER OPERATION

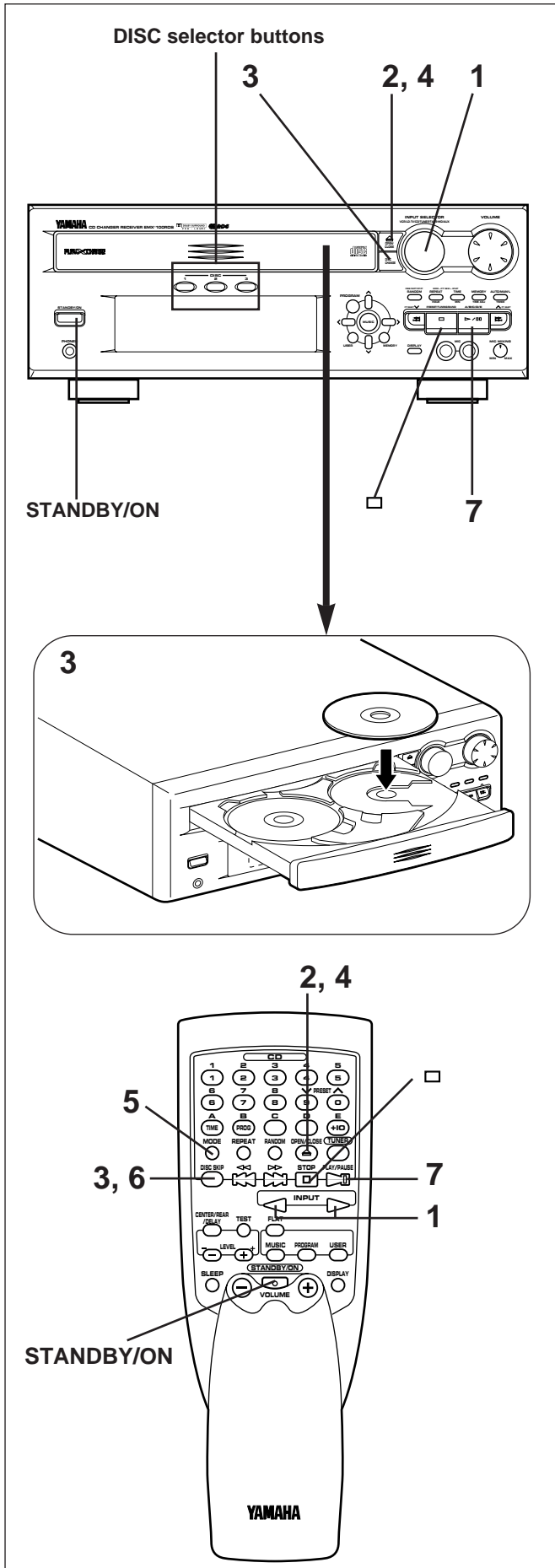

## CD playback

- 1** Select the CD player by turning the INPUT SELECTOR until "CD" appears on the display.
- 2** Press the OPEN/CLOSE button to open the disc table.
- 3** Place discs on the trays, label side up.
  - \* Up to three discs can be loaded on the trays.
  - To load the third disc, rotate the disc table by pressing the DISC CHANGE button on the front panel or the DISC SKIP button on the remote control transmitter.
  - \* 8 cm (3") discs may be played without an adaptor.
- 4** Press the OPEN/CLOSE button to close the disc table.
  - \* The total number of tracks and the total playing time of the disc being selected will be displayed for several seconds.
  - \* The music calendar will be displayed only for the number of tracks on the disc being selected.
  - \* If the compact disc contains more than 15 tracks, the "OVER 15" indicator will light up on the music calendar.

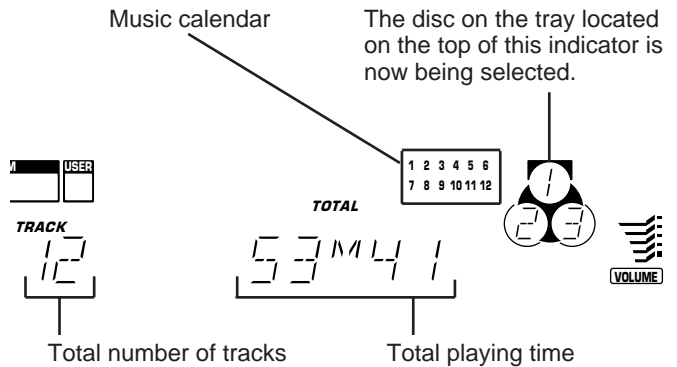

- 5** If necessary, change the disc play mode by pressing the disc play MODE selector button on the remote control transmitter watching the display.

**Single disc play mode:** Only a designated disc is played back.

**All disc play mode:** All discs on the disc table are played back sequentially.

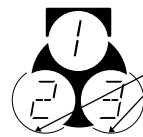

Lights up only when the all disc play mode is selected.

- 6** If necessary, select another disc by pressing the DISC SKIP button on the remote control transmitter once or more (so that the corresponding disc tray number is located on the top of the disc indicator).
- 7** Press the play/pause button to start playback from track 1.
  - \* The "▷" indicator will appear and playback will begin. As the playback of each track on the music calendar is finished, that track number will go out.

### For easier operation

Pressing the DISC selector button (1, 2 or 3) will select the disc directly, and playback will begin from track 1 automatically.





# COMPACT DISC PLAYER OPERATION

## To interrupt playback

- 1 Press the play/pause ▷/⏸ button.  
\* The “▷” indicator will flash.
- 2 Press the play/pause ▷/⏸ button to resume playback from the same point.

## To stop playback

Press the stop □ button.

## To turn the unit into the standby mode after use

Turn this unit into the standby mode by pressing the STANDBY/ON switch. (The indicators will go off except for the current time display.)

## Direct operation

When this unit is in the standby mode, pressing the DISC selector (1, 2 or 3) button will turn the power on and start CD playback automatically.

When the power is on, even if an input source other than CD player is selected, pressing a DISC selector button or closing the disc table by pushing the front edge of the disc table gently will start playback directly.

\* These ways of playback can also be used to close the disc table. If the table is closed in these ways, playback will begin automatically, however, the display will not show the total number of tracks and the total playing time of the disc to be played back.

## PLAYXCHANGE

During playback, you can open the disc table by pressing the DISC CHANGE button without interrupting playback. However, in this case, pressing the DISC SKIP button or a DISC selector button has no effect.

## Note

You can load or replace discs on the trays when the disc table is opening, however, never load a disc on the tray hidden inside the unit. In doing so, the disc and the unit may be damaged, because the tray already has a disc, which is being played back.

## Precautions

- Subjecting the unit to shock or vibration can cause mistracking.
- Playing back some compact discs at high volume can cause mistracking. In this case, listen at lower volume.
- Do not pull open the disc table forcibly with your hands.
- Do not push the disc table while it is moving.
- If the power fails while the table is open, wait until the power supply returns or gently push the table manually to close it.
- The temperature range for playing back compact discs is recommended to be 5°C (41°F) – 35°C (95°F).

## Direct-selection playback

By using the track number input buttons on the remote control transmitter, any track you wish to listen to can be played back directly.

Use the track number input buttons to select the desired track number. Playback will begin automatically.

**A. For example, to choose selection 5**  
Press the “5” button.

**B. For example, to choose selection 12**  
(1) Press the “+10” button.  
(2) Within a few seconds, press “2” button.

**C. For example, to choose selection 20**  
(1) Press the “+10” button.  
(2) Within a few seconds, press the “+10” button again.  
(3) Within a few seconds, press the “0” button.

## Note

If you select a track number higher than the number of tracks on the disc, playback may begin from the last track on the disc.

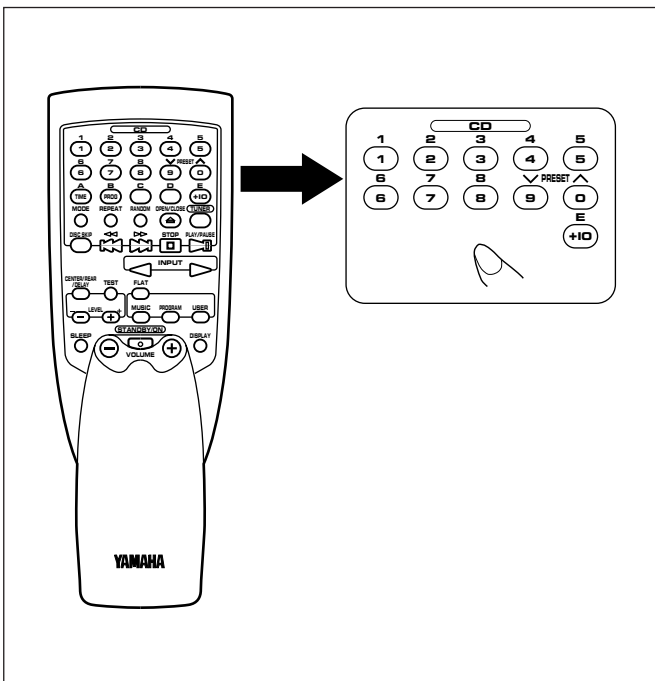



## COMPACT DISC PLAYER OPERATION

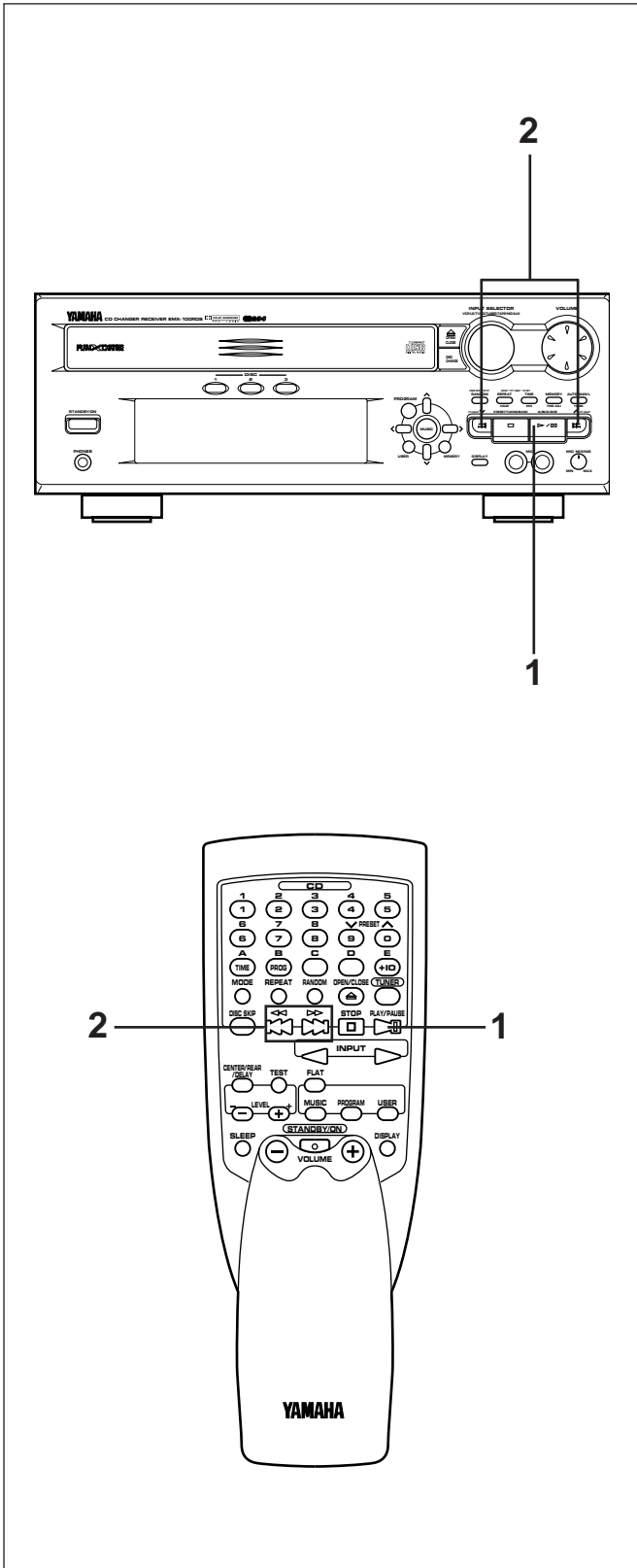

“Skip search” and “Manual search” are performed using the same buttons.

### To play a desired track on the disc (Skip search)

The beginning of any track can be found automatically.

- 1 Select a disc and begin playback.
- 2 Press the  $\triangleright\triangleright$  button to advance or  $\triangleleft\triangleleft$  button to reverse through the disc. Press once for each track to be advanced or reversed.
  - Press  $\triangleright\triangleright$  once to advance to the track following the one now playing back.
  - Press  $\triangleleft\triangleleft$  once to return to the start of the track now playing back.
  - Press  $\triangleleft\triangleleft$  twice to return to the track before the track now playing back.

#### Notes

- This function can also be performed while the CD player is stopped. Press the play/pause  $\triangleright/\square$  button when your desired track number appears on the track number display. Playback will begin from the beginning of the track.
- This function will be performed forward or backward from any point on the disc. However, it will not move forward during playback of the final track.

### To advance or reverse play rapidly (Manual search)

- 1 Begin playback.
- 2 Press and hold the  $\triangleright\triangleright$  button to advance playback rapidly, and the  $\triangleleft\triangleleft$  button to reverse playback rapidly.
  - \* The sound can be heard (although slightly garbled) during manual search in either direction. This is convenient for reviewing the contents quickly.

#### Note

Manual search can also be performed while playback is paused, though no sound will be heard.



# COMPACT DISC PLAYER OPERATION

## Program play

You can program up to 20 tracks in any desired order.

- 1 Load discs and close the disc table.
- 2 When in the stop mode, press the PROG button to prepare for programming.
  - \* "PROG" and "P-01" will light up on the display, and all track numbers on the selected disc will begin flashing.
- 3 If necessary, select a desired disc by pressing the DISC SKIP button.
  - \* Just after you changes the disc, this unit reads the contents of the newly selected disc for a few seconds. During this internal operation, if you go on to the next step, "WAIT" appears on the display and your operation is canceled.
- 4 Use the track number input buttons to select the desired track number.
  - \* The selected track number and the total play time of the programmed tracks will light up on the display, and soon it will be replaced by the display of the next playback order. Programmed track numbers on the selected disc will stop flashing and light up on the music calendar.
  - \* Pressing the TIME button displays the total play time of the programmed tracks for about 1 second, and then it is replaced by the display of the next playback order.
  - \* **For example, to choose selection 12**
    - (1) Press the "+10" button.
    - (2) Within 3 seconds, press the "2" button.
- 5 Repeat steps 3 and 4 for any other track. Up to 20 tracks can be programmed.
- 6 Press the play/pause button to start playback of programmed tracks.

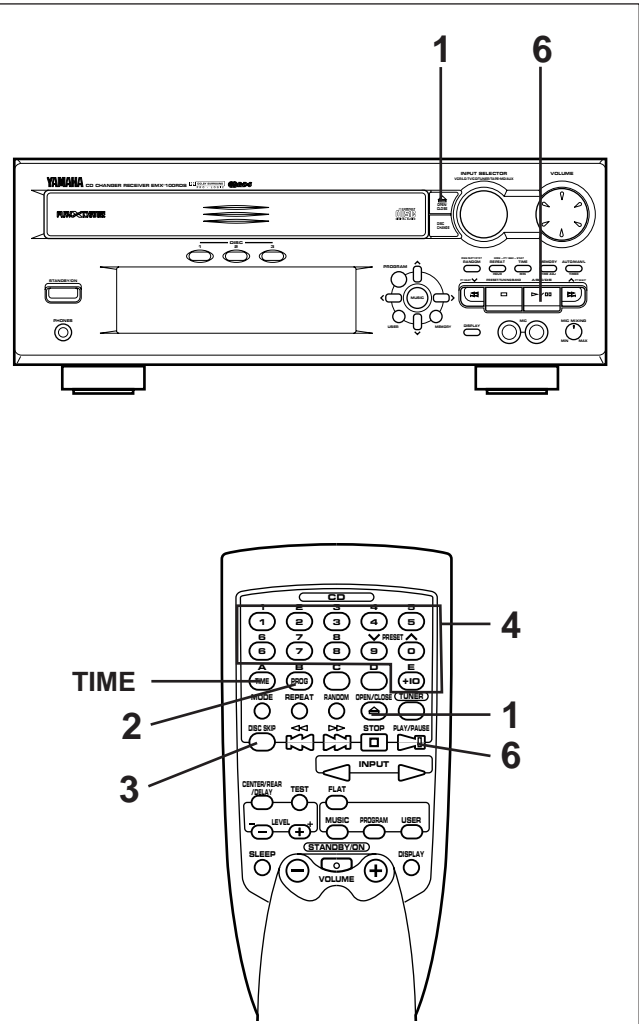

### Display information during programming

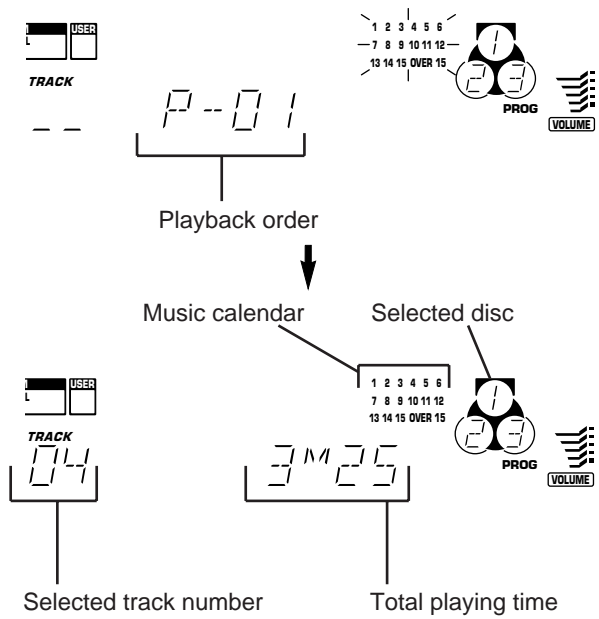

### Notes

- It is also possible to program a sequence of tracks while looking at the list of tracks on the surface of the disc before closing the disc table.
- During playback or pause, programming is not possible.
- If the total time of the programmed tracks becomes 100 minutes or more, the highest position of the figure will not be displayed.
- The total time of the programmed tracks will not be displayed, if track number 16 or higher is programmed.
- Skip search can be performed during playback, but only within the range of the programmed tracks.
- Manual search can be performed during playback to search all tracks, including unprogrammed tracks.
- If programs are made selecting tracks from more than one disc, pressing the DISC CHANGE button is useless during program play.



## COMPACT DISC PLAYER OPERATION

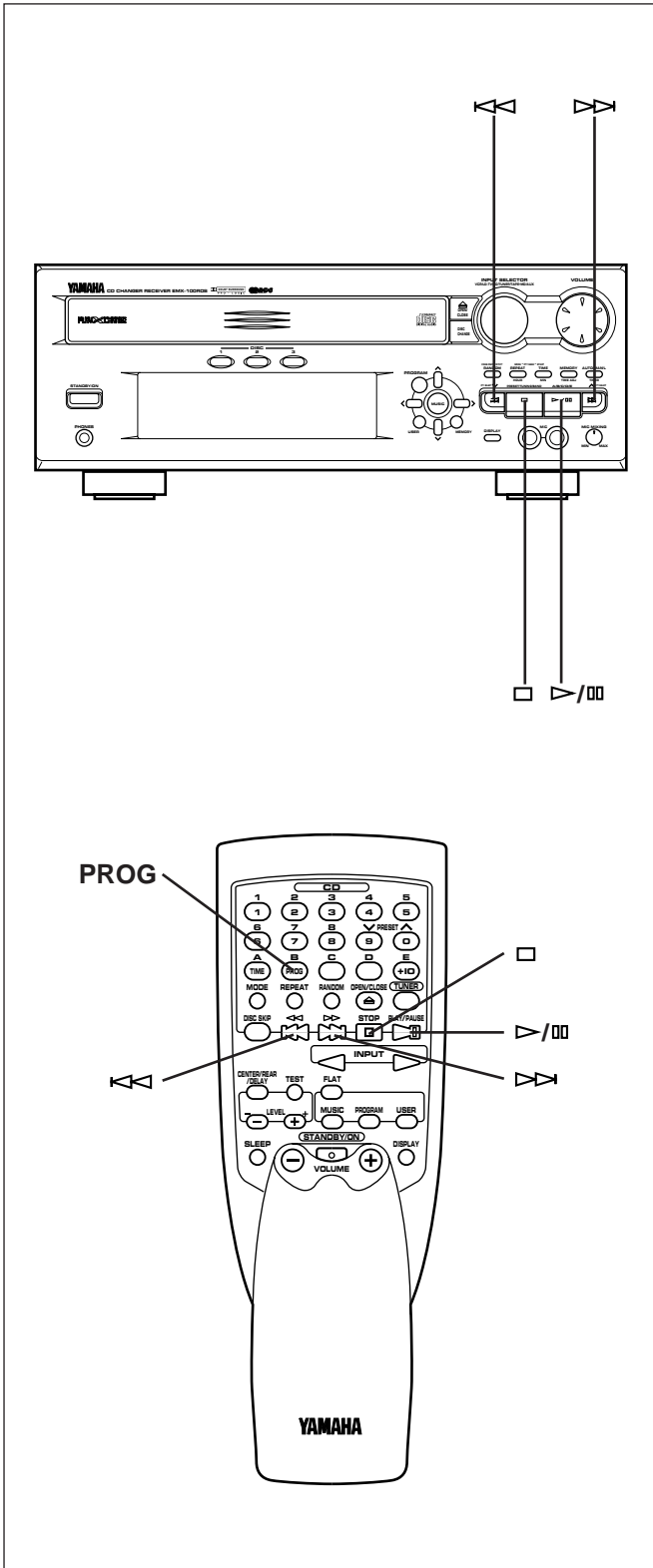

### To stop program play

- Press the stop  $\square$  button. The first programmed track number will be displayed.
- To resume playback, press the play/pause  $\triangleright/\square$  button. Playback will begin from the beginning of the program.

### To cancel a programmed sequence

There are several methods as described below.

- Press the stop  $\square$  button while the unit is stopped.
- Open the disc table
- Turn this unit into the standby mode.

### To check program data

1. If during playing back, press the stop  $\square$  button.
2. Press the PROG button.
3. Each time the  $\triangleright\triangleright$  button is pressed, the track numbers and sequential order of the programmed tracks can be checked one after another. The display of the track number can be returned (sequentially in reverse order) by pressing the  $\triangleleft\triangleleft$  button.

### To correct program data

1. Follow the procedure described in "To check program data".
2. Display the track number to be corrected by pressing the  $\triangleright\triangleright$  or  $\triangleleft\triangleleft$  button.
3. Press a track number input button to select a track to replace the one displayed. The previously programmed track will be cleared from the memory and the new one will be programmed.
4. When the correction is finished, press the PROG button or play/pause  $\triangleright/\square$  button once again.



# COMPACT DISC PLAYER OPERATION

## Repeat play

All discs, an entire disc, a single track or a programmed sequence can be continuously repeated.

- 1 While watching the display, press the REPEAT button once or more to select a desired repeat play mode (S REP or F REP).
- 2 Press the play/pause  $\blacktriangleright / \square$  button.

## Repeat play modes

### SINGLE REPEAT (S REP)

A single track is played back repeatedly.  
 \* This is also available in the program play mode and the random play mode. (If the repeat play mode is switched off, the program play mode or the random play mode will be resumed.)

### FULL REPEAT (F REP)

#### When the unit is in the single disc play mode:

A designated disc is played back repeatedly.  
 \* In the random play mode, the selected disc is repeatedly played back, but the order of tracks is different every time.

#### When the unit is in the all disc play mode:

All discs on the disc table are played back repeatedly.  
 \* In the random play mode, the random play is performed among all discs and repeated with a different order of tracks every time.

#### Note

In the program play mode, a sequence of programmed tracks is played back repeatedly.

## To cancel the repeat play

Press the REPEAT button once or more so that the (S, F) REP indicator goes out.

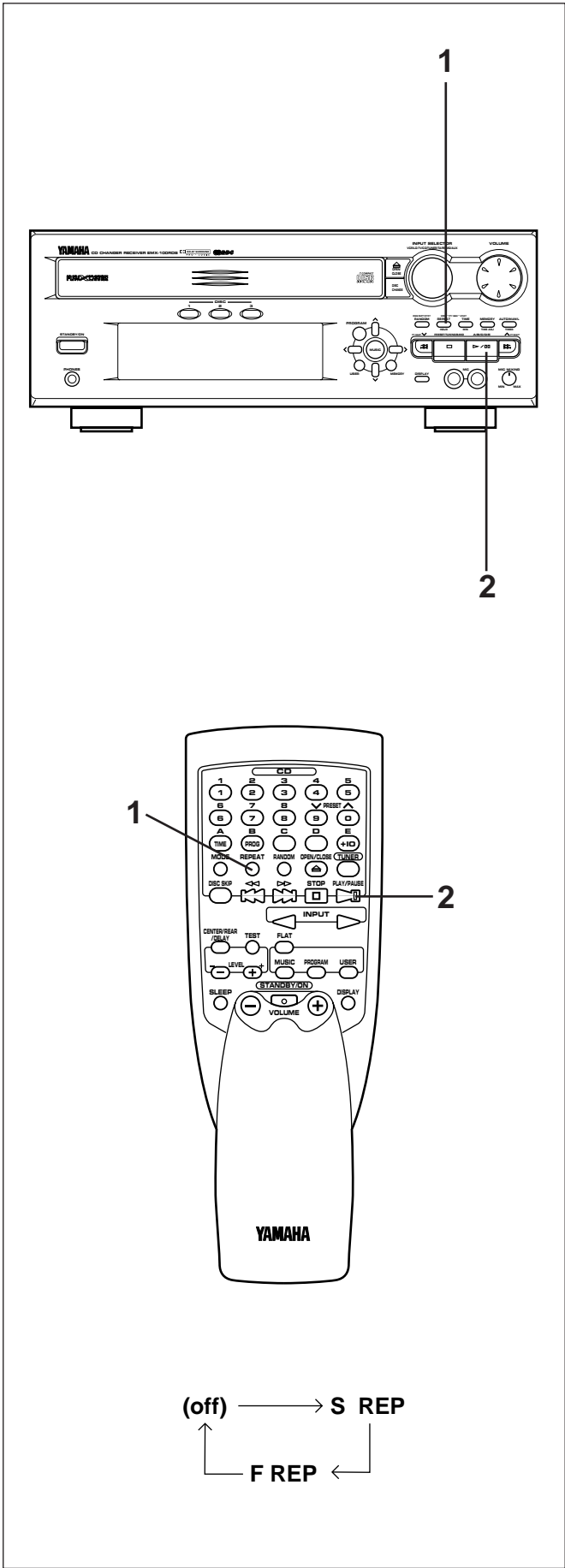



## COMPACT DISC PLAYER OPERATION

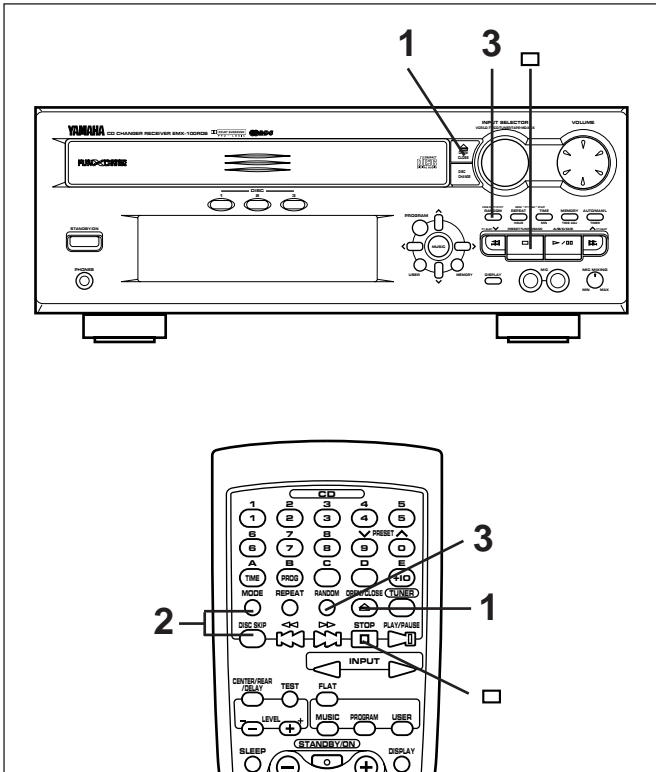

### Random play

Tracks on a selected disc or all discs on the disc table can be played back in a random order.

- 1 Load discs and close the disc table.
- 2 If necessary, switch the disc play mode by pressing the disc play MODE selector button.
  - \* If the single disc play mode is selected, select a desired disc by pressing the DISC SKIP button.
- 3 Press the RANDOM button to begin random play.
  - \* The "RANDOM" indicator will light up.

#### To cancel the random play

Press the stop  button, or press the RANDOM button again. The "RANDOM" indicator will go out.

#### Note

This feature will not function during programming, or during program play.

### Switching the time display

Each time the TIME button is pressed, the display will change as described below.

#### [Example]

When the second track is being played back (Refer to the illustration on the left.)

- ① The elapsed play time for the track now playing back will be displayed.
  - \* 8 seconds have passed since the beginning of the second track.
- ② The remaining play time for the current track will be displayed.
  - \* 2 minutes and 58 seconds remain till the end of the second track.
- ③ The total play time of the disc will be displayed. (If the unit is in the program play mode, the total play time of the programmed tracks will be displayed.)
- ④ The total remaining play time from the point being played at that time will be displayed.
  - \* 41 minutes remain till the end of the disc.

#### Notes

- During random play, the total remaining play time on the disc will not be displayed.
- The remaining play time will not be displayed for track number 16 or higher.
- If track number 16 or higher is programmed, during the program play, the total play time and the total remaining play time will not be displayed.

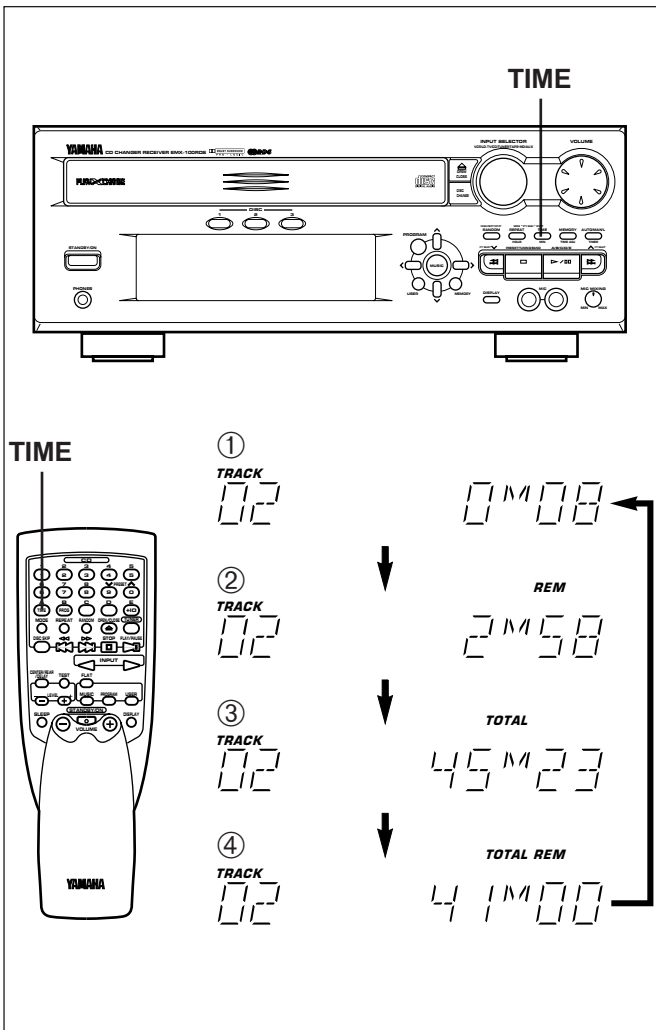

## TUNING OPERATION

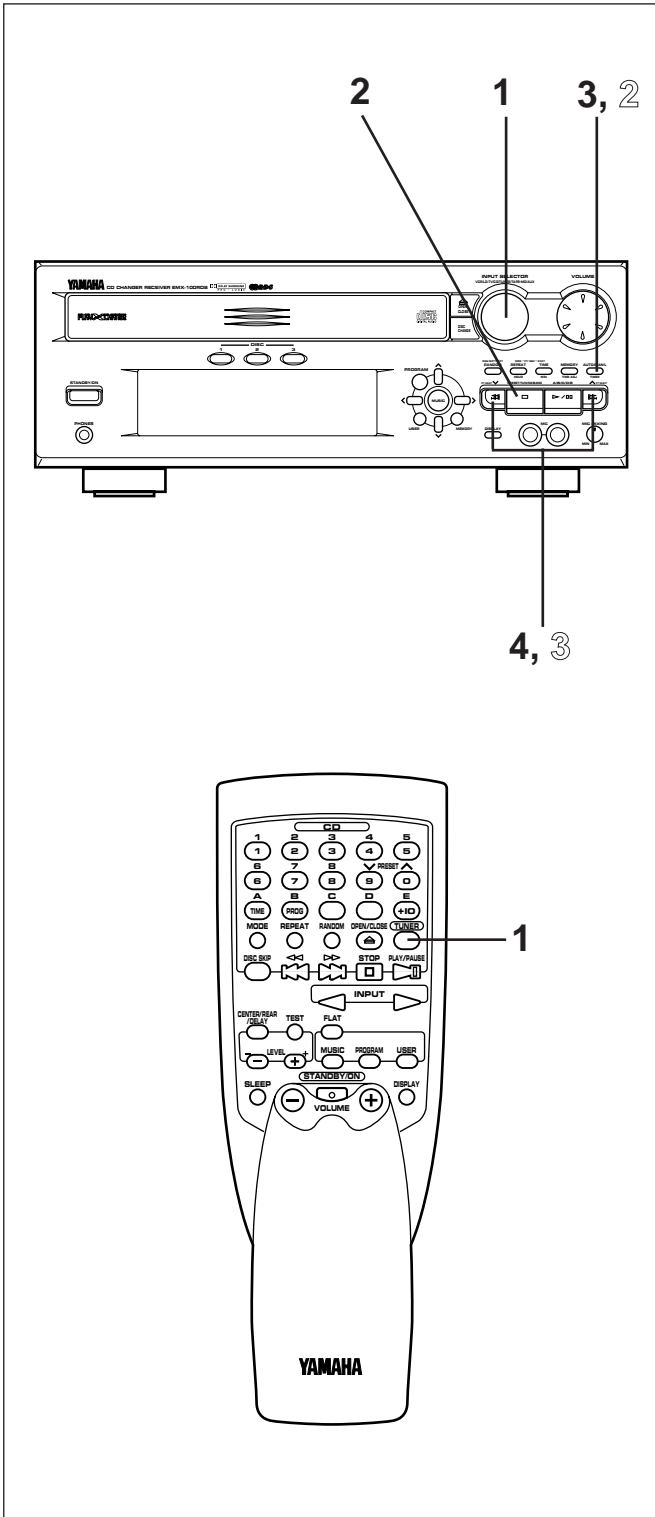

Normally, if station signals are strong and there is no interference, quick automatic-search tuning (Automatic tuning) is possible. However, if signals of the station you want to select are weak, you must tune to it manually (Manual tuning).

### Automatic tuning

- 1 Select the tuner by turning the INPUT SELECTOR until "TUNER" appears on the display.
- 2 Select the reception band [FM or AM (MW or LW)] by pressing the PRESET/TUNING/BAND button confirming it on the display.
  - \* Do not select a preset tuning mode (in which "PRESET" lights up on the display.)
- 3 Press the AUTO/MAN'L button so that "AUTO" appears on the display. (In this mode, stations are received in stereo or monaural automatically.)
- 4 Press the ^ button to tune to a higher frequency, or press the v button to tune to a lower frequency. (When tuned in to a station, "TUNED" will light up on the display.)
- 5 If the station where tuning search stopped is not the desired one, follow step 4 again.
  - \* If the tuning search does not stop at the desired station, change to the Manual tuning method as described below.
  - \* STEREO indicator will light up when an FM stereo broadcast with sufficient signal strength is received.

### Manual tuning

- 1 Follow steps 1 and 2 of the Automatic tuning method.
- 2 Press the AUTO/MAN'L button so that "AUTO" disappears from the display. (In this mode, stations are received in monaural.)
- 3 Press and hold the ^ button to tune to a higher frequency, or press and hold the v button to tune to a lower frequency. Release it just before reaching the desired frequency, and then press it repeatedly until the desired frequency appears. (When tuned in to a station, "TUNED" will light up on the display.)

#### Note

If you tune in to an FM station manually, it is received in monaural automatically to increase the signal quality.

#### Note

Pressing the TUNER input selector button on the remote control transmitter switches the tuner from a normal tuning mode to a preset tuning mode and vice versa.



## TUNING OPERATION

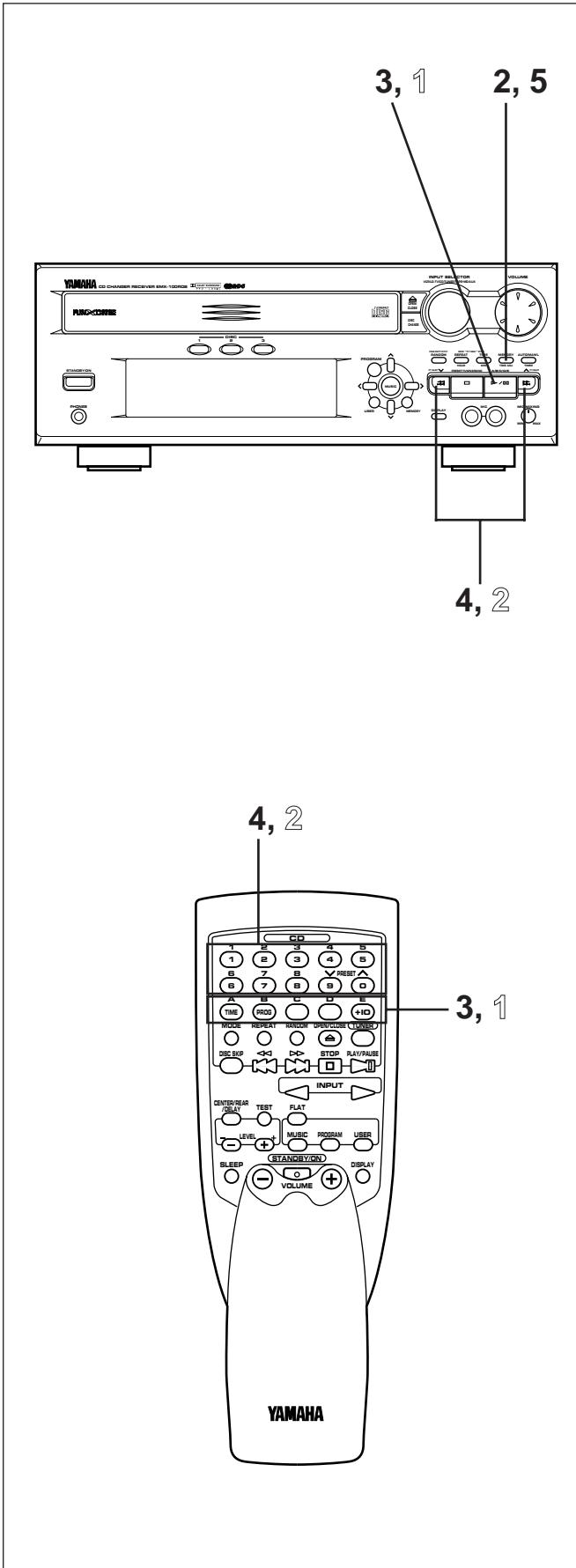

### Manual preset tuning

This unit can store station frequencies selected by tuning operation. With this function, you can select any desired station only by calling the corresponding preset station number. Up to 40 stations (8 stations x 5 groups) can be stored.

#### To store stations

(Example: To store a station to A1)

- 1 Tune in to a desired station.  
(Refer to the previous page for tuning procedure.)
- 2 Press the tuner MEMORY button.  
\* "MEMORY" and "PRESET" will flash on the display for about 5 seconds.
- 3 Select a desired group (A – E) of preset stations by pressing the A/B/C/D/E button confirming it on the display, before "MEMORY" goes out.  
(In this case, select group A.)
- 4 Select a preset station number by pressing the  $\vee$  or  $\wedge$  button repeatedly before "MEMORY" goes out.  
(In this case, select "1".)
- 5 Within about 5 seconds, press the tuner MEMORY button again.

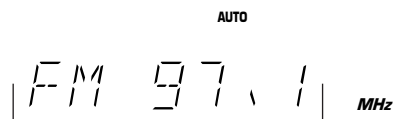

The currently displayed station has been programmed to A1.

- \* In the same way, program other stations to A2, A3 ... A8.
- \* You can program more stations to the preset station numbers of other groups in the same way by selecting other groups in step 3.

#### To recall a preset station

- 1 Select a group of preset stations by pressing the A/B/C/D/E button.
- 2 Select the desired preset station number by pressing the  $\vee$  or  $\wedge$  button repeatedly.

#### Notes

- A new setting can be programmed in place of the former one.
- For presets the setting of the AUTO/MAN'L button is stored along with the station frequency.

#### For easier operation

By using the preset station number buttons and the A,B,C,D,E selector buttons on the remote control transmitter, a preset station number and a group can be selected directly.



## TUNING OPERATION

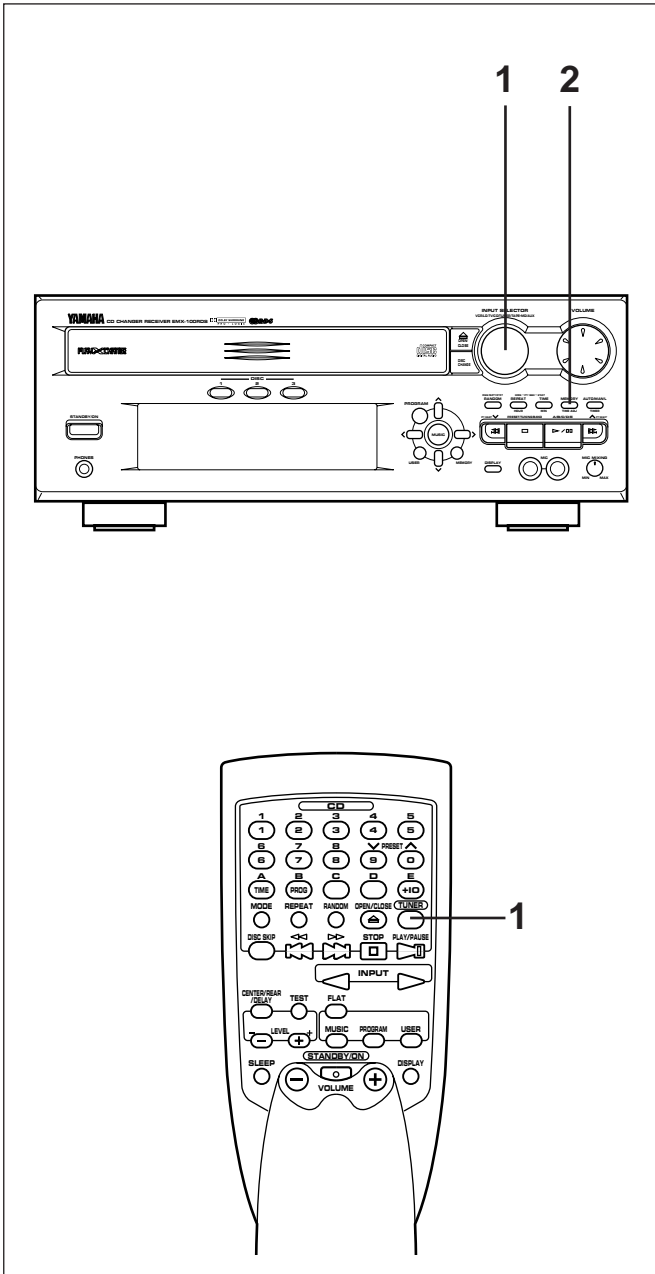

### Automatic preset tuning

You can also make use of an automatic preset tuning function. By this function, this unit performs automatic tuning and stores stations with strong signals sequentially. Up to 40 stations are stored automatically in the same way as in the manual preset tuning method on the previous page.

- 1 Select the tuner by turning the INPUT SELECTOR until "TUNER" appears on the display.
- 2 Press and hold the tuner MEMORY button for more than 2 seconds.
  - \* The MEMORY and AUTO indicators will flash.

This unit performs automatic tuning and searches FM and AM (MW and LW for U.K. and Europe models only) stations in that order. Received stations are programmed to A1, A2 ... A8 sequentially.

#### When the automatic preset tuning is completed

The display shows the frequencies of the first preset station (stored to A1).

Check the contents and the number of preset stations by following the procedure of the section "To recall a preset station" on the previous page.

#### To recall a preset station

Simply follow the procedure of the section "To recall a preset station" on the previous page.

#### Notes

- The automatic preset tuning search will be performed through all frequencies until 40 stations are stored. If the number of received stations is less than 40, the search will stop after searching all frequencies.
  - \* Since FM stations are searched for first, there may be a case that 40 preset stations are occupied by FM stations only.
- The unit is originally set so that only RDS stations are searched instead of all FM stations by this operation. (FM stations that employ no RDS network service cannot be programmed.)  
However, you can change the setting so that the unit can program not only RDS stations but also other FM stations. (Refer to page 29 for details.)
- With this function, only stations with sufficient signal strength are stored automatically. If the station you want to program is weak in signal strength, tune to it in monaural manually and program it by following the procedure of the section "To store stations" on the previous page.
- You can replace a preset station with another FM or AM (MW or LW) station manually by simply following the procedure of the section "To store stations" on the previous page.

#### Memory back-up

The memory back-up circuit prevents the programmed data from being lost even if the AC supply lead is disconnected from the AC outlet or the power is cut due to temporary power failure. If, however, the power is cut for more than one week, the memory may be erased. If so, it can be re-programmed by simply following the preset tuning steps.



## RECEIVING RDS STATIONS

RDS (Radio Data System) is a data transmission system gradually being introduced by FM stations in many countries. Stations using this system transmit an inaudible stream of data in addition to the normal radio signal.

RDS data contains various information, such as PI (Program Identification), PS (Program Service name), PTY (Program Type), RT (Radio Text), CT (Clock Time), etc.

RDS function is carried out among the network stations.

\* This unit utilizes PS, PTY, RT and CT to receive RDS broadcast stations.

### Displaying RDS data

This unit can be turned into the following four modes to display RDS data.

#### PS (Program Service name) mode:

Displays the name of the RDS station now being received instead of the frequency.

**BBC R3**

#### PTY (Program Type) mode:

Displays the type of the program on the RDS station now being received. There are 15 program types to classify RDS stations as follows.

#### **NEWS**

##### **News:**

Short accounts of facts, events and publicly expressed views, reportage and actuality.

#### **AFFAIRS**

##### **Current affairs:**

Topical program expanding or enlarging upon the news, generally in different presentation style or concept, including documentary debate, or analysis

#### **INFO**

##### **Information:**

Program whose purpose is to impart advice in the widest sense, including meteorological reports and forecasts, consumer affairs, medical help, etc.

#### **SPORT**

##### **Sport:**

Program concerned with any aspect of sport.

#### **EDUCATE**

##### **Education:**

Program intended primarily to educate, of which the formal element is fundamental.

#### **DRAMA**

##### **Drama:**

All radio plays and serials.

#### **CULTURE**

##### **Culture:**

Programs concerned with any aspect of national or regional culture, including religious affairs, philosophy, social science, language, theatre, etc.

#### **SCIENCE**

##### **Science:**

Programs about the natural sciences and technology.

#### RT (Radio Text) mode:

Displays information about the program (such as title of the song, name of the singer, etc.) on the RDS station now being received.

#### CT (Clock Time) mode:

Displays current time. This signal comes from the RDS station now being received. Time of the built-in clock can be automatically corrected on the basis of this signal.

#### **VARIED**

##### **Varied:**

Used for mainly speech-based programs usually of light-entertainment nature, not covered by above categories. Examples are: quizzes, panel games, personality interviews, comedy and satire.

#### **POP M**

##### **Pop:**

Commercial music, which would generally be considered to be of current popular appeal, often featuring in current or recent record sales charts.

#### **ROCK M**

##### **Rock:**

Contemporary modern music, usually written and performed by young musicians.

#### **M.O.R. M**

##### **M.O.R.:**

(Middle of the Road Music). Common term to describe music considered to be "easy-listening", as opposed to Pop, Rock or Classical. Music in this category is often but not always, vocal, and usually of short duration (<5 min.)

#### **LIGHT M**

##### **Light classics:**

Classical Musical for general, rather than specialist appreciation. Examples of music in this category are instrumental music, and vocal or choral works.

#### **CLASSICS**

##### **Serious classics:**

Performances of major orchestral works, symphonies, chamber music etc., and including Grand Opera.

#### **OTHER M**

##### **Other music:**

Musical styles not fitting into any of the above categories. Particularly used for specialist music, of which Jazz, Rhythm & Blues, Folk, Country, and Reggae are examples.

## RECEIVING RDS STATIONS

### Changing the RDS modes

When an RDS station is received, by pressing the **FREQ PS/PTY/RT/CT** selector button once or more, you can change the display mode among the RDS modes employed by the received station in the order shown below. (The RDS mode not employed by the station cannot be selected.)

#### Notes

- If the received station is not an RDS station, pressing the **FREQ PS/PTY/RT/CT** selector button displays "NO RDS" on the display, and then it returns to the frequency display mode.
- When an RDS station is received, the display is automatically turned into the PS mode. Do not press the **FREQ PS/PTY/RT/CT** selector button until the display is turned into the PS mode. If the button is pressed before the display mode changes, it may occur that "NO PS" appears on the display. This is because the unit has not received all of the RDS data on the station yet.

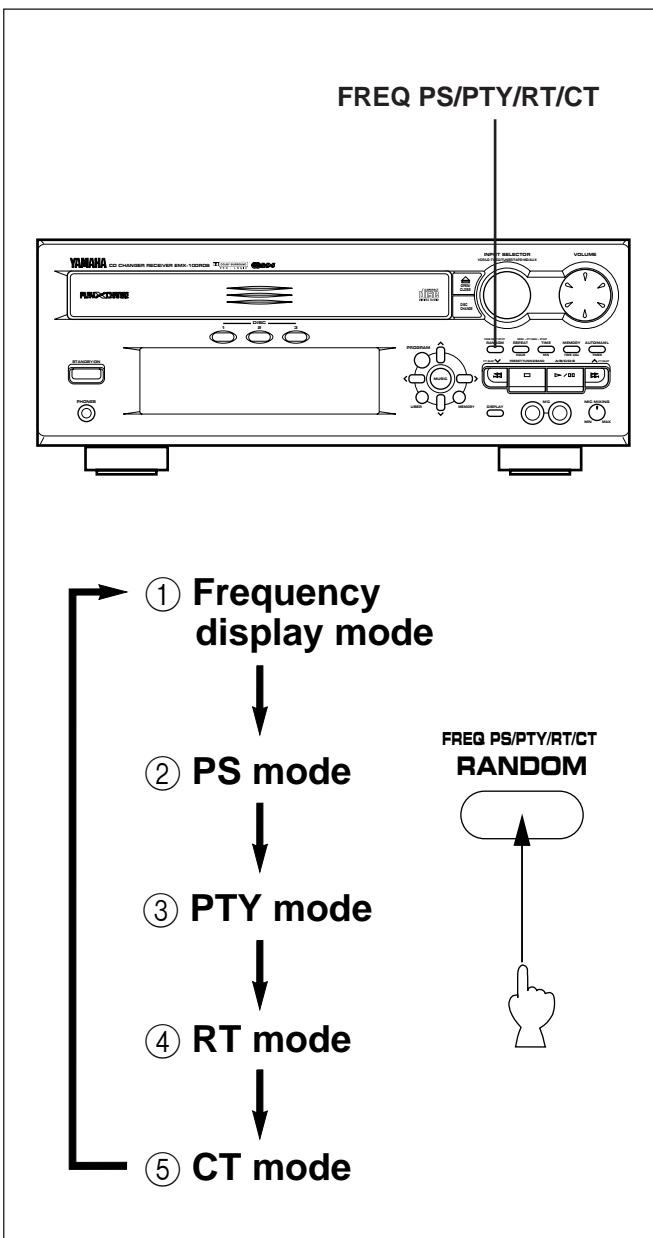

- ① **Frequency display mode**  
The frequency of the station being received is displayed.
- ② **PS (Program Service name) mode**  
The name of the station being received is displayed using characters selected from among 64 Roman Alphabets including umlaut sign.
  - \* If other characters are used on the PS data, they are displayed with underbars.
  - \* "PS WAIT" may flash while the unit is receiving the data.
  - \* If the station does not employ the PS data service, "NO PS" lights up on the display for about 2 seconds and then returns to frequency display mode.
- ③ **PTY (Program Type) mode**  
The type of the program on the station being received is displayed. In this mode, you can make this unit search for a station which is broadcasting a program of your desired program type. For details, refer to the next page.
  - \* If the RDS station does not employ the PTY data service, "NO PTY" lights up on the display for about 2 seconds and then returns to frequency display mode. If the station has PS data, after that, it turns into the PS mode.
- ④ **RT (Radio Text) mode**  
Information about the program on the station being received is displayed. Information is displayed by a maximum of 64 Roman Alphabets including umlaut sign.
  - \* If other characters are used on the RT data, they are displayed with underbars.
  - \* "RT WAIT" may flash while the unit is receiving the data.
  - \* If the RDS station does not employ the RT data service, "NO RT" lights up on the display for about 2 seconds and then returns to frequency display mode. If the station has PS data, after that, it turns into the PS mode.
- ⑤ **CT (Clock Time) mode**  
Current time is displayed in the following form. The CT data from the station being received changes every minute.

[ 1 0 0 ] - [ 0 0 ]

Hour                      Minute

This unit corrects the time of the built-in clock by synchronizing it with the CT data. (This function can also be canceled, if so desired. Refer to page 29 for details.)

- \* "CT WAIT" may flash while the unit is receiving the data. If the data is accidentally cut off, "CT WAIT" may flash and then turn into "NO CT".
- \* If the RDS station does not employ the CT data service, "NO CT" lights up on the display for about 2 seconds and then returns to frequency display mode. If the station has PS data, after that, it turns into the PS mode.



## RECEIVING RDS STATIONS

### Notes

- RDS data service cannot be utilized by this unit if the received signal is not strong enough. Especially, the RT (Radio Text mode) needs much data to be received, so it may occur that RT mode cannot be displayed even if other RDS modes (PS, PTY, etc.) are displayed.

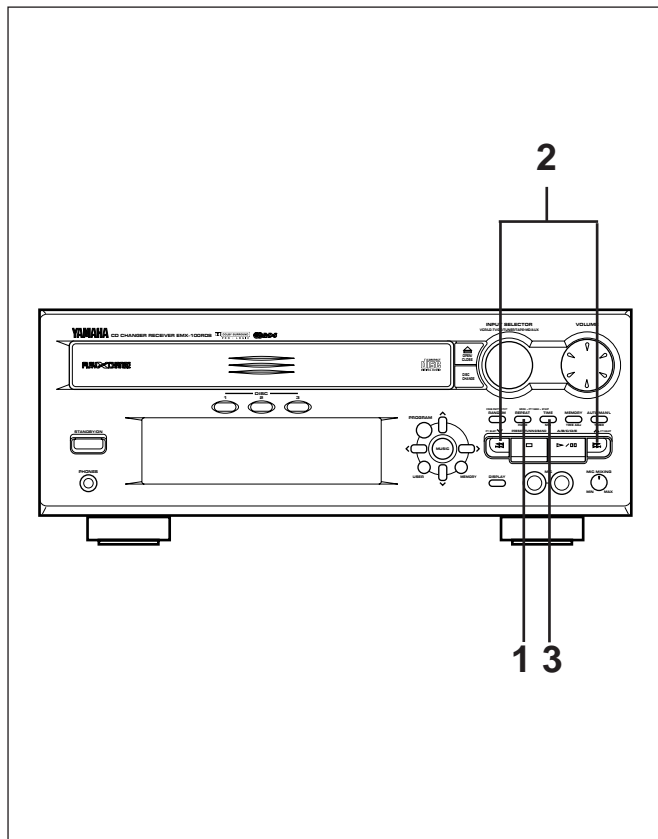

- There may be a case that RDS data reception is not possible due to poor reception conditions. If so, press the AUTO/MAN'L button so that "AUTO" goes off from the display. Though the reception mode is changed to monaural by this operation, when you change the display to an RDS mode, RDS data may be displayed.
- If the signal strength gets weakened by external interference during receiving an RDS station, the RDS data service may be cut off suddenly and turn into the frequency display mode.

## Calling a program of your desired program type from among preset RDS stations (PTY SEEK)

By designating a program type, the unit automatically searches all preset FM stations for an RDS station which broadcasts a program of that program type.

\* There are 15 program types to classify RDS stations. For details, refer to page 26.

- 1** Turn the unit into the PTY SEEK mode by pressing the PTY SEEK MODE button.
  - \* The name of the program type of the station now being received or "NEWS" flashes on the display.
- 2** Select the desired program type with the PTY SELECT  $\checkmark$  or  $\wedge$  button.
  - \* If there is no operation for about 20 seconds, this mode is canceled and turns into the frequency display. If the station has PS data, after that, it turns into the PS mode.
- 3** Press the PTY SEEK START button.
  - The unit begins searching all preset FM stations.
  - \* "PTY HOLD" lights up on the display.
  - \* The preset number indicator, the name of the program type and "AUTO" flash. The preset station number changes rapidly in sequence.

- If a station which broadcasts a program of the program type is found, the unit stops at the station and turns into the frequency display. If the station has PS data, after that, it turns into the PS mode.
- If the called station is not the desired one, press the PTY SEEK START button once more before "PTY HOLD" goes out from the display. The unit begins searching for another station which broadcasts a program of the same program type.
- If no station is found, "NO PTY" appears and then returns to frequency display. If the station has PS data, after that, it turns into the PS mode.
  - \* If the PTY SEEK START button is pressed once more during searching, this mode is canceled and turns into the frequency display. If the station has PS data, after that, it turns into the PS mode.

### To cancel this function

If the PTY SEEK MODE button is pressed once more, the PTY SEEK mode is canceled and turns into the frequency display. If the station has PS data, after that, it turns into the PS mode.



## RECEIVING RDS STATIONS

### Other functions which make use of RDS data service

This unit has the following functions which make use of RDS data service. These are originally in operation [ON]. However, you can cancel these functions [OFF], if so desired.

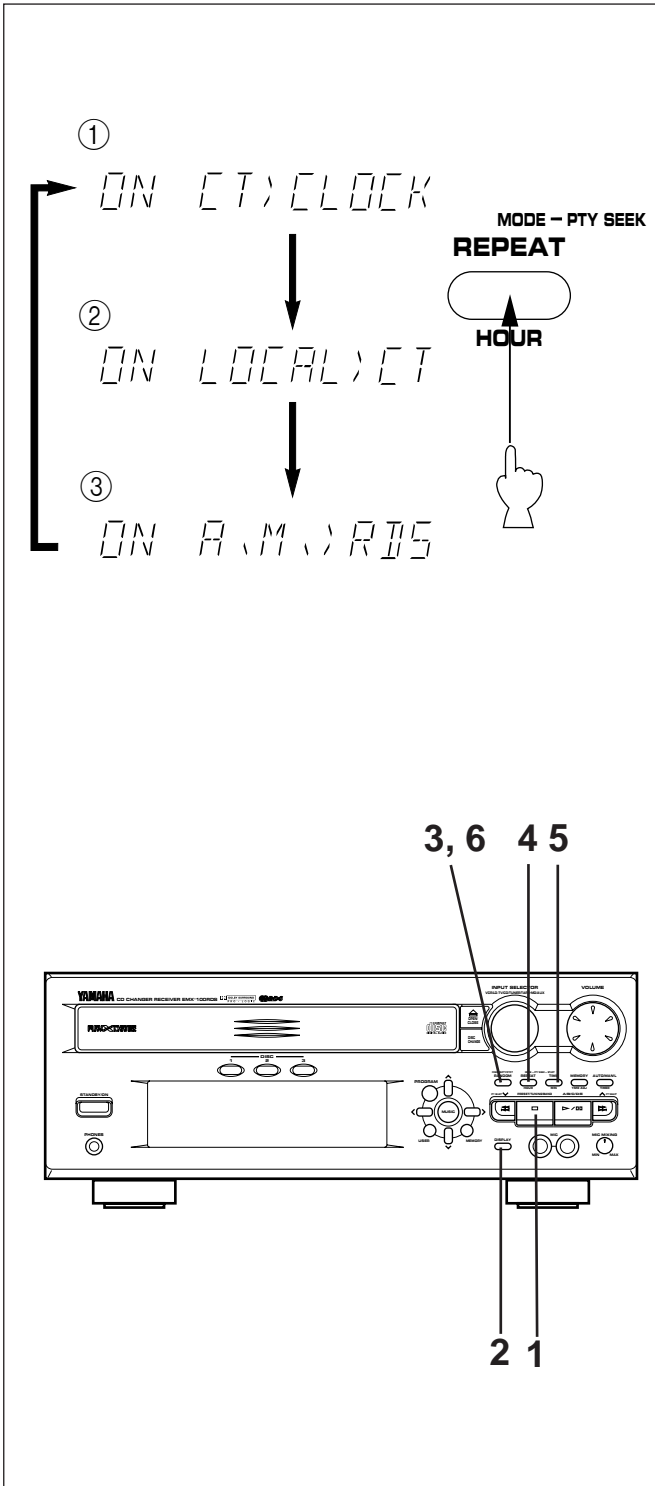

#### ① ON (OFF) CT > CLOCK

This unit corrects the time of the built-in clock automatically by synchronizing it with the CT data on the RDS station being received.

- \* If you receive an RDS station of some other country, the built-in clock is synchronized with the time setting of the country.
- \* If the built-in clock is not yet set for current time or reset due to a power failure etc., it will be set for the time of the CT data automatically, whether this setting is ON or OFF.

#### ② ON (OFF) LOCAL > CT

If the RDS station being received employs the local time (summer time etc.) data service, its time is displayed in the CT mode.

- \* If the setting of function ① is "ON", the built-in clock is synchronized with the local time data.

#### ③ ON (OFF) A.M. > RDS

Only RDS stations are searched instead of all FM stations by the automatic preset tuning operation when the setting is ON.

(Refer to page 25 for the operating procedure.)

If you switch this function OFF, not only RDS stations but also other FM stations are programmed along with MW and LW stations by the automatic preset tuning operation.

#### To switch these functions on and off

- 1 Select the FM band by pressing the PRESET/TUNING/BAND button, confirming it on the display.
- 2 Press the DISPLAY button to display the current time.
- 3 Press the FREQ PS/PTY/RT/CT selector button. The title of function ① "ON CT > CLOCK" is displayed.
- 4 Select the title of function whose setting you want to switch by pressing the PTY SEEK MODE button once or more.
- 5 Switch the function ON or OFF by pressing the PTY SEEK START button, confirming it on the display.
- 6 Press the FREQ PS/PTY/RT/CT selector button again to restore the frequency display mode.
  - \* If the station has PS data, after the frequency display mode returns, it turns into the PS mode.

#### Notes

- Once the setting is changed, it will be stored until it is changed again by the above operation.
- During the operation, if there is no operation for about 20 seconds, this mode is canceled and turns into the frequency display. If the station has PS data, after that, it turns into the PS mode.

## OPERATING EXTERNAL UNITS CONNECTED WITH THIS UNIT

### To listen to or watch a source on an external unit connected with this unit

- 1 Select the position of input source (TAPE-MD, AUX, VCR or LD-TV) you will play back by turning the INPUT SELECTOR until the corresponding name appears on the display.  
\* The names of input source positions correspond with the names of terminals to connect with external units on the rear of this unit.
- 2 Play back the source.  
(For a video source, turn the monitor TV on.)
- 3 Adjust the volume to a desired level by using the VOLUME control.  
If you prefer, use the graphic equalizer and/or the sound field processor built into this unit.

### To record a source to tape

Not only a source played back on this unit, but also a source played back on an external unit can be recorded by the tape deck, VCR, MD recorder, etc. connected with this unit.

- 1 Select the source you want to record by turning the INPUT SELECTOR.
- 2 Play back the source and then turn the VOLUME control up to confirm the input source.
- 3 Begin recording on the tape deck or VCR etc. connected with this unit.

#### Note

If the built-in graphic equalizer and/or sound field processor is used, its effect is recorded along with the source when you make recording on the recording unit connected to the TAPE-MD terminals on the rear of this unit. However, the effect of the graphic equalizer and/or sound field processor cannot be recorded when you make recording on the external recording unit connected to the VCR terminals on the rear of this unit.

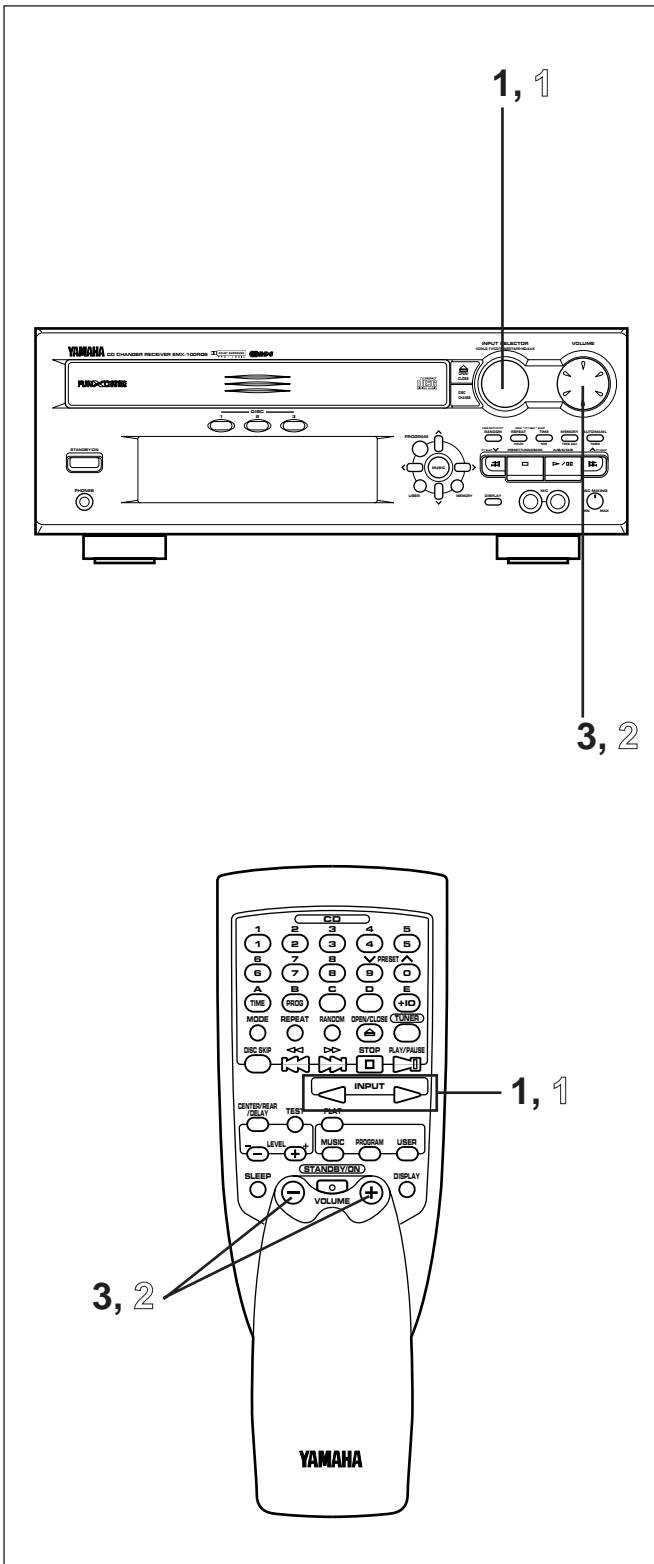

## USING GRAPHIC EQUALIZER

The built-in graphic equalizer presents you with the pleasure of listening to music with various sound effects. This unit provides 4 preset equalizer modes as listed right. You can enjoy listening to music with a desired sound effect by selecting one of these modes. In addition, the built-in 5 band graphic equalizer allows you to adjust the equalizer pattern to create an effect for your desired sound taste.

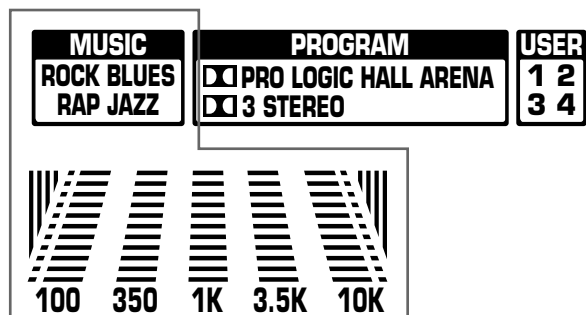

### Preset graphic equalizer modes (MUSIC)

Mode	Feature
<b>ROCK</b>	High and low frequencies are emphasized. This mode is suitable for reproducing dynamic and powerful sounds of rock music etc.
<b>BLUES</b>	Low and medium frequencies are moderately emphasized. This mode is suitable for music with a blue feeling.
<b>RAP</b>	Low and mid-high frequencies are emphasized so that vocals become well-modulated. This mode is suitable for rap music etc.
<b>JAZZ</b>	Medium frequencies for vocals, piano, sax, etc. are emphasized. High and low frequencies are also emphasized moderately.

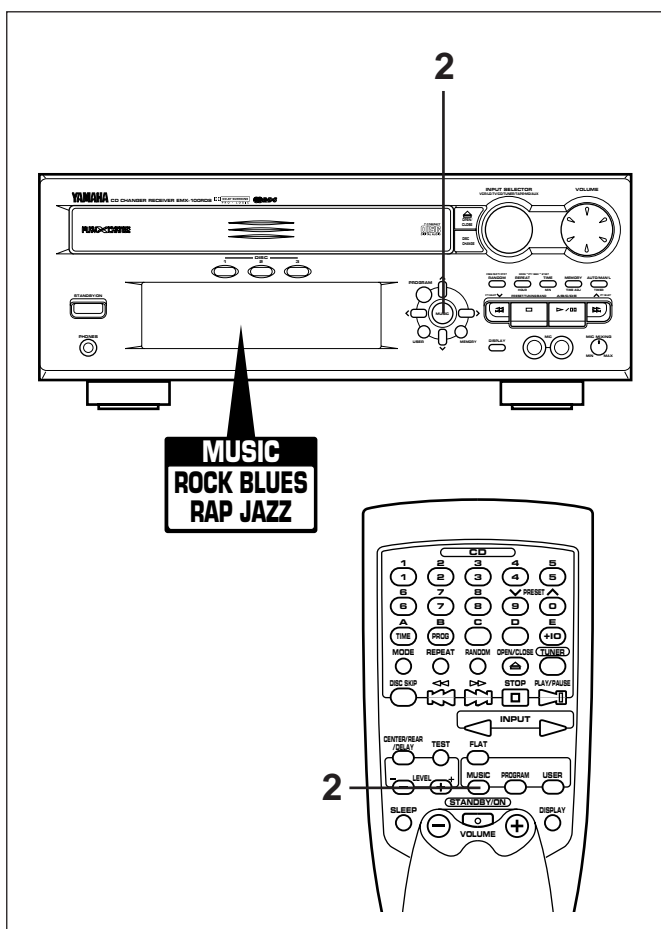

### Listening to the music with a preset equalizer effect

- 1 Play back a source. (For source playback, refer to pages 16 to 30)
- 2 Press the MUSIC button once or more so that the name of a desired mode appears on the preset equalizer mode indicator.
  - \* Whenever you press the MUSIC button, the preset mode changes and is displayed as follows.

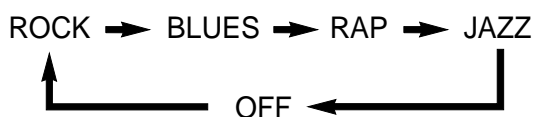

\* The equalizer pattern of the selected mode is shown on the graphic equalizer level indicators.

## USING GRAPHIC EQUALIZER

### Adjusting the graphic equalizer for your desired sound taste

The 5 band graphic equalizer allows you to adjust the level for each frequency band.

\* Make adjustment by monitoring the equalizer level indicators on the display.

- 1 Play back a source. (For source playback, refer to pages 16 to 30)
- 2 Press the equalizer control < or > button once or more to select the frequency band to which you will adjust the level.
  - \* The selected frequency band is shown on the display.
  - \* The scale bar of the selected frequency band on the graphic equalizer level indicators will flash.
- 3 Press the equalizer control ^ or v button once or more to adjust the level.
- 4 In the same way, make adjustment for other frequency band.

### Turning the equalizer to “flat” (the state with no equalization applied)

By one of the following methods, the settings of preset graphic equalizer mode (MUSIC) and sound field program (PROGRAM) are turned off and the equalizer pattern is turned to “flat”.

- Press the FLAT button on the remote control transmitter.
  - \* Pressing the FLAT button once more will restore the state before the equalizer was turned to “flat”.
- Press the MUSIC button and the PROGRAM button on the front panel at the same time.
  - \* There is no way to restore the state before the equalizer was turned to “flat”.

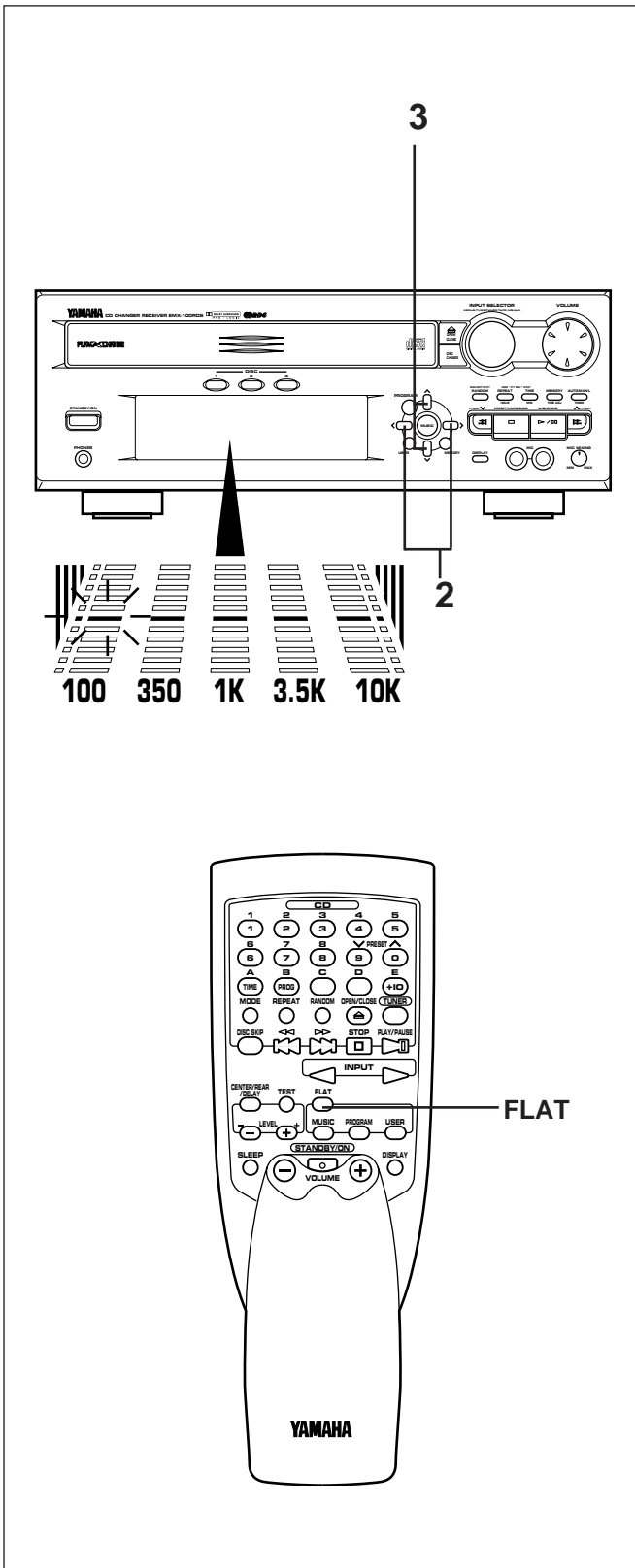



## USING SOUND FIELD PROCESSOR

The Sound Field Processor built into this unit presents you with the ambience of an actual concert hall etc. by adding effects as sonic reflections or reverberations that create the sound environment of a hall etc. This unit provides preset sound field programs shown below. You can enjoy an excellent audio sound field by selecting one of them, and adding desired adjustments.

This unit incorporates a Dolby Pro Logic Surround decoder for multi-channel sound reproduction of Dolby Surround encoded video sources. The operation of the Dolby Pro Logic Surround decoder can be controlled by selecting a corresponding sound field program.



### Brief Overview of Sound Field Programs

PROGRAM	FEATURE
<input checked="" type="checkbox"/> PRO LOGIC	This program is used for playback of sources encoded with Dolby Surround. Sounds are reproduced as movie creators designed by using five speakers. You can experience the dramatic realism and impact of a movie theater.
<input checked="" type="checkbox"/> 3 STEREO	This program is effective not only for playback of sources encoded with Dolby Surround, but also for sources not encoded with Dolby Surround or TV programs with 2-channel stereo sound. With this program, 2-channel stereo sound is converted into 3-channels (left front, center and right front), so the dialogs are emphasized on the center position by the use of the center speaker. As no sound is output from the rear speakers, this program is also effective in a simple Audio/Video system without rear speakers.
HALL	In this program, the center will appear to be deep behind the front speakers, creating an expansive large hall ambience. Orchestra and opera music are suited for this sound field.
ARENA	This program simulates the sound environment of a big hall with long reverberation time and many reflections of high frequencies.

## USING SOUND FIELD PROCESSOR

### Listening to the music with a sound field effect

- 1 Play back a source. (For source playback, refer to pages 16 to 30)
- 2 Press the PROGRAM button once or more so that the name of a desired program appears on the sound field program indicator.
  - \* Whenever you press the PROGRAM button, the program changes and is displayed as follows.

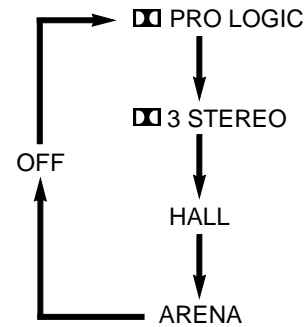

- 3 If desired, adjust the delay time and the output level of each speaker. (For details, refer to the corresponding descriptions on pages 35 to 36)

#### Notes

- When HALL or ARENA is selected, no sound is heard from the center speaker.
- When a monaural sound source is played with  PRO LOGIC, no sound is heard from the rear speakers.
- If you play back a source not encoded with the Dolby Pro Logic Surround when  PRO LOGIC is selected, the source may not be played back normally.

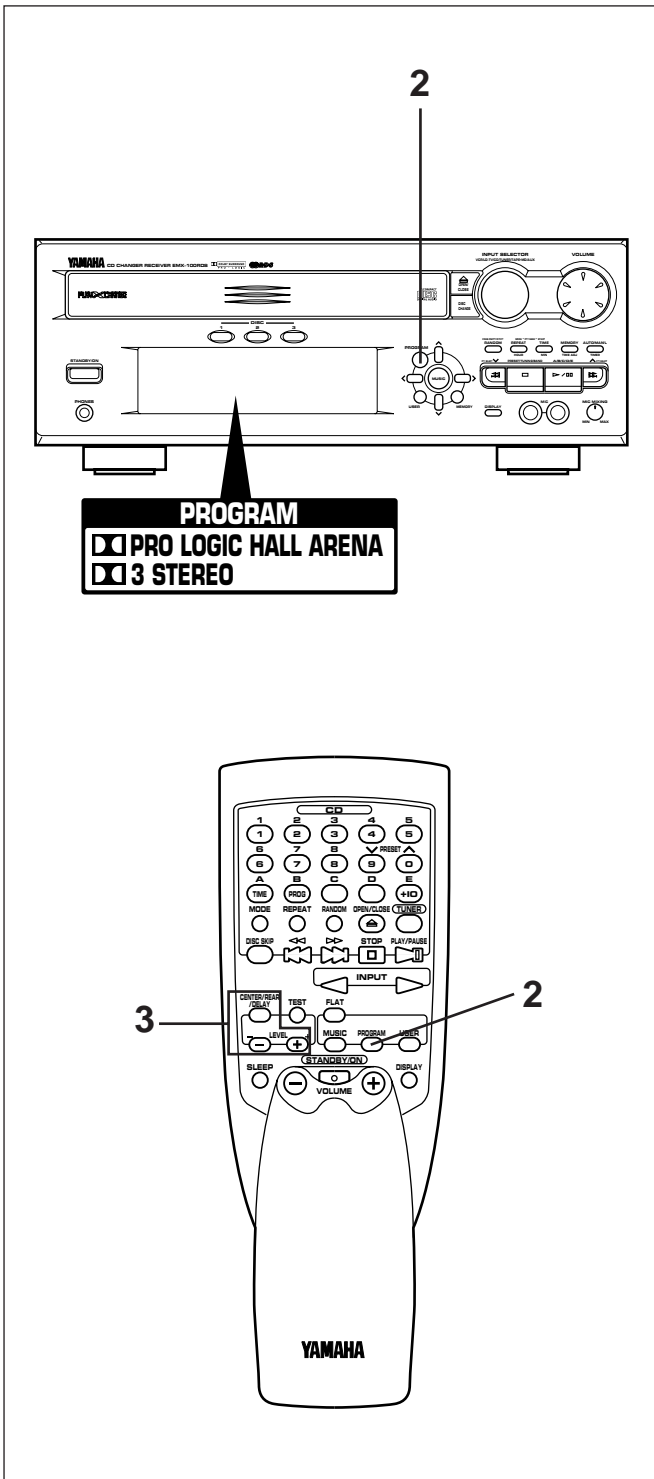

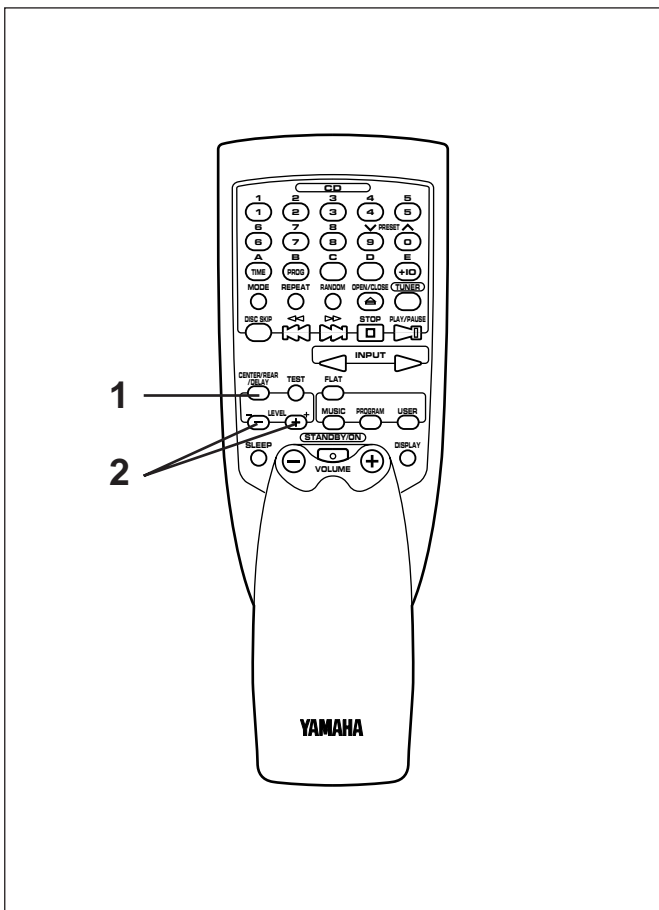

## Adjusting CENTER LEVEL

If desired, you can adjust the sound output level of the center speaker even if the output level is already set in "SPEAKER BALANCE ADJUSTMENT" on pages 14 to 15.

**Control range** : +10 to -21

- 1** Press the CENTER/REAR/DELAY selector button once or more so that "CENT" appears on the display.
- 2** By continuously pressing the LEVEL control + or - button, the level value changes continuously.

### Notes

- This adjustment can be made only when the sound field program DOLBY PRO LOGIC or DOLBY 3 STEREO is selected.
- Once the output level is adjusted, the level value will be the same in the DOLBY PRO LOGIC and DOLBY 3 STEREO programs.
- If the center channel mode is in the "PHANTOM" position, the sound output level of the center speaker cannot be adjusted. This is because in this mode, the center sound is automatically output from the left and right front speakers.

## Adjusting REAR LEVEL

If desired, you can adjust the sound output level of the rear speakers even if the output level is already set in "SPEAKER BALANCE ADJUSTMENT" on pages 14 to 15.

**Control range** : +10 to -21

- 1** Press the CENTER/REAR/DELAY selector button once or more so that "REAR" appears on the display.
- 2** By continuously pressing the LEVEL control + or - button, the level value changes continuously.

### Notes

- This adjustment can be made when a sound field program except DOLBY 3 STEREO is selected.
- Adjustment can be made to DOLBY PRO LOGIC, HALL and ARENA individually.

## USING SOUND FIELD PROCESSOR

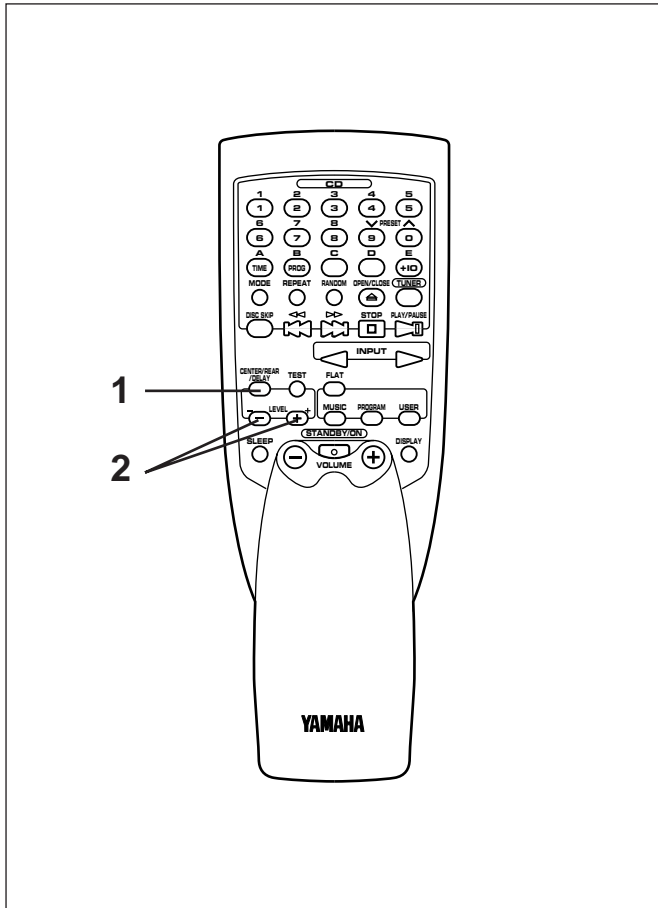

### Adjusting DELAY TIME

You can adjust the time difference between the beginning of the sound from the main speakers and the beginning of the effect sound from the rear speakers.

The larger the value, the later the effect sound is generated. This adjustment can be made to all programs (except DOLBY 3 STEREO) individually.

#### Control range

**PRO LOGIC** : 15, 20, 25, 30 milliseconds

**HALL, ARENA** : 15, 20, 25, 30, 40, 50 milliseconds

- 1 Press the CENTER/REAR/DELAY selector button once or more so that "DEL" appears on the display.

DEL 20ms

- 2 By continuously pressing the LEVEL control + or - button, the value changes continuously. The value stops changing momentarily at the preset point.

DEL 25ms  
Adjustable

#### Notes

- When DOLBY 3 STEREO is selected, this adjustment cannot be made.
- Adding too much delay will cause an unnatural effect with some sources.
- When the LEVEL control button is pressed, sound is momentarily interrupted.

#### Note

The values of the delay time, center level and rear level you set the last time will remain memorized even when this unit is in the standby mode.

However, if the power cord is kept disconnected for more than one week, these values will be automatically changed back to the original factory settings.

## STORING YOUR OWN PROGRAMS

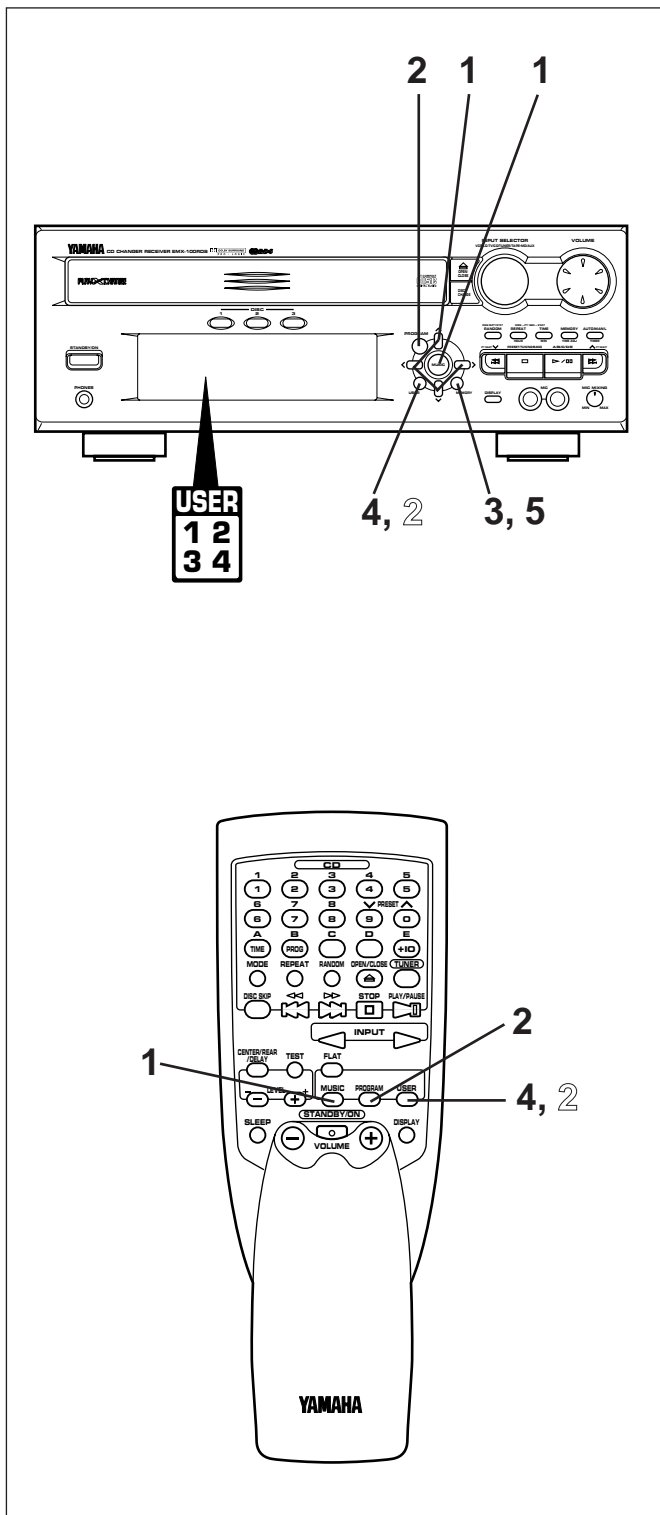

Your favorite pair of any equalizer mode (or an equalizer pattern of your own adjusting) and any sound field program can be stored as a user program. Up to 4 pairs can be stored as desired.

### To store

- 1 Select a desired equalizer mode by pressing the MUSIC button.  
\* If desired, adjust the equalizer as you prefer by using the equalizer control buttons.
- 2 Select a desired sound field program by pressing the PROGRAM button.
- 3 Press the user program MEMORY button.  
\* "1" will flash on the user program number indicator and the MEMORY indicator will flash for about 5 seconds.
- 4 Select the user program number (1, 2, 3 or 4) to which you will store the selected modes by pressing the USER button once or more before "1" stops flashing.  
\* Whenever you press the USER button, the user program number changes and is displayed as follows.

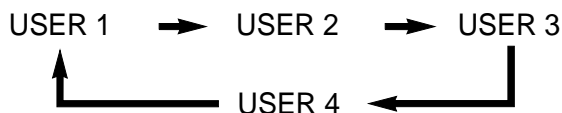

- 5 Press the user program MEMORY button before the number selected in step 4 stops flashing.

- \* In the same way, store other pairs to other three user positions.
- \* It is also a good idea to store only an equalizer pattern of your own adjusting (without storing any sound field program).

### Notes

- A new program can be stored in place of the former one.
- In step 4 or 5, if the user program number indicator stops flashing before operation, return to step 3.

### To recall a user program

- 1 Play back a source. (For source playback, refer to pages 16 to 30)
- 2 Press the USER button once or more so that the user program number you want to recall lights up.  
\* Whenever you press the USER button, the user program number changes and is displayed as follows.

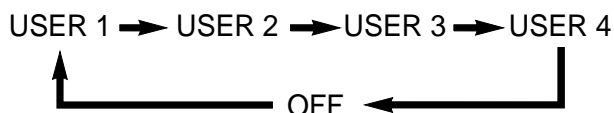

## SINGING KARAOKE BY USING MICROPHONES

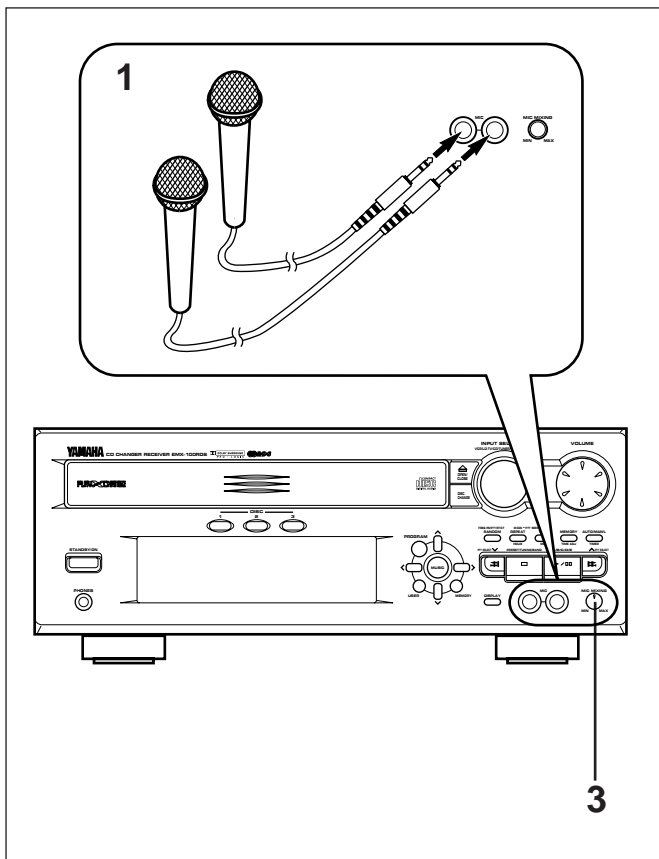

This unit is equipped with two MIC jacks and a MIC MIXING level control. These are available for singing karaoke or some other use.

- 1 Connect one or two microphones to the MIC jack(s) on the front panel.
- 2 Play back a karaoke source, and sing karaoke by using the microphones. (For source playback, refer to pages 16 to 30)
- 3 While singing, adjust the mixing level of singing voice by turning the MIC MIXING level control.

### Note

You can record sound signals input from the microphone(s) along with the selected input source onto a tape (or MD) by using a tape deck, MD recorder, etc. connected to this unit.

## LISTENING WITH HEADPHONES

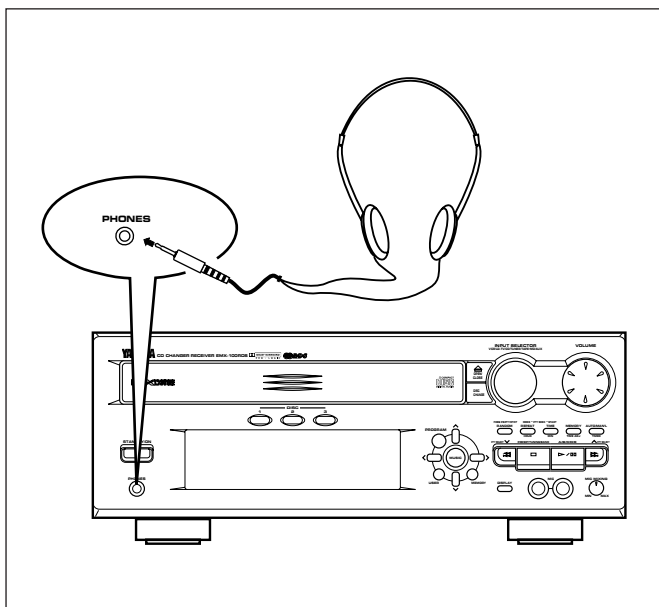

- Be sure that your headphones have a 3.5 mm (1/8") diameter plug and are between 16 ohms and 50 ohms impedance. Recommended impedance is 32 ohms.
- When headphones are connected, the speakers are defeated automatically and you can listen to the sound to be output from the front speakers through headphones. Adjust the VOLUME control for desired volume.

## HOW TO USE THE BUILT-IN TIMER

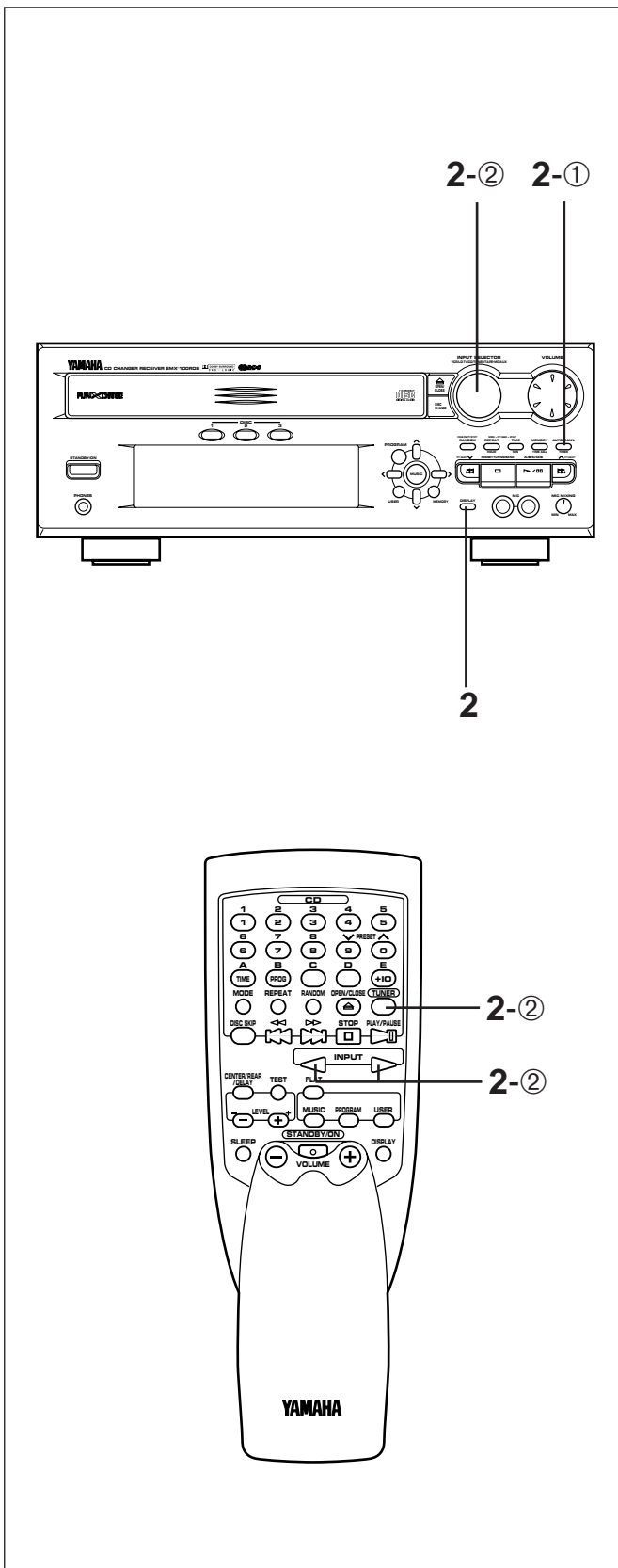

### Timer play

By using the built-in timer, you can set the time when the unit turns on and a source begins playing automatically, and the time when the unit turns into the standby mode automatically.

- 1 Prepare the source to be played.

**For tuner:**

Tune in to the station you will listen to.

**For CD player:**

Load a disc on the disc table. If more than one disc are loaded on the disc table, select the disc by using the DISC selector buttons or the DISC SKIP button.

- 2 Press the DISPLAY button. Whenever the DISPLAY button is pressed, the display mode changes as follows. On each mode, make a setting for the timer play, following the setting procedure described below.

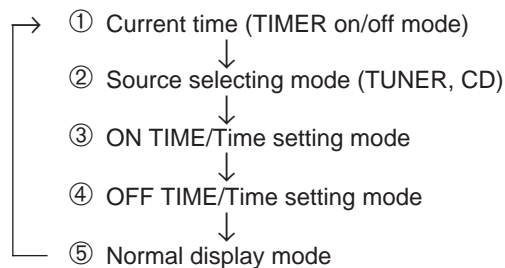

**Note**

The display mode will be changed to the next mode after about 8 seconds elapse in turn automatically. If the mode is changed before the setting is completed, call the mode again by pressing the DISPLAY button once or more.

**Setting procedure:**

- ① **Current time**  
Check to be sure that the current time is correct, and press the TIMER button so that "TIMER" lights up on the display.
- ② **Source selecting mode**  
Select the source (TUNER or CD) to be played with the INPUT SELECTOR.  
\* If "TUNER" is selected, soon it is changed to the frequency display mode. In this mode, you can select the station to listen to by the timer play by using the PRESET/TUNING/BAND selector button, A/B/C/D/E button and ^ / v buttons.

**CONTINUED**

## HOW TO USE THE BUILT-IN TIMER

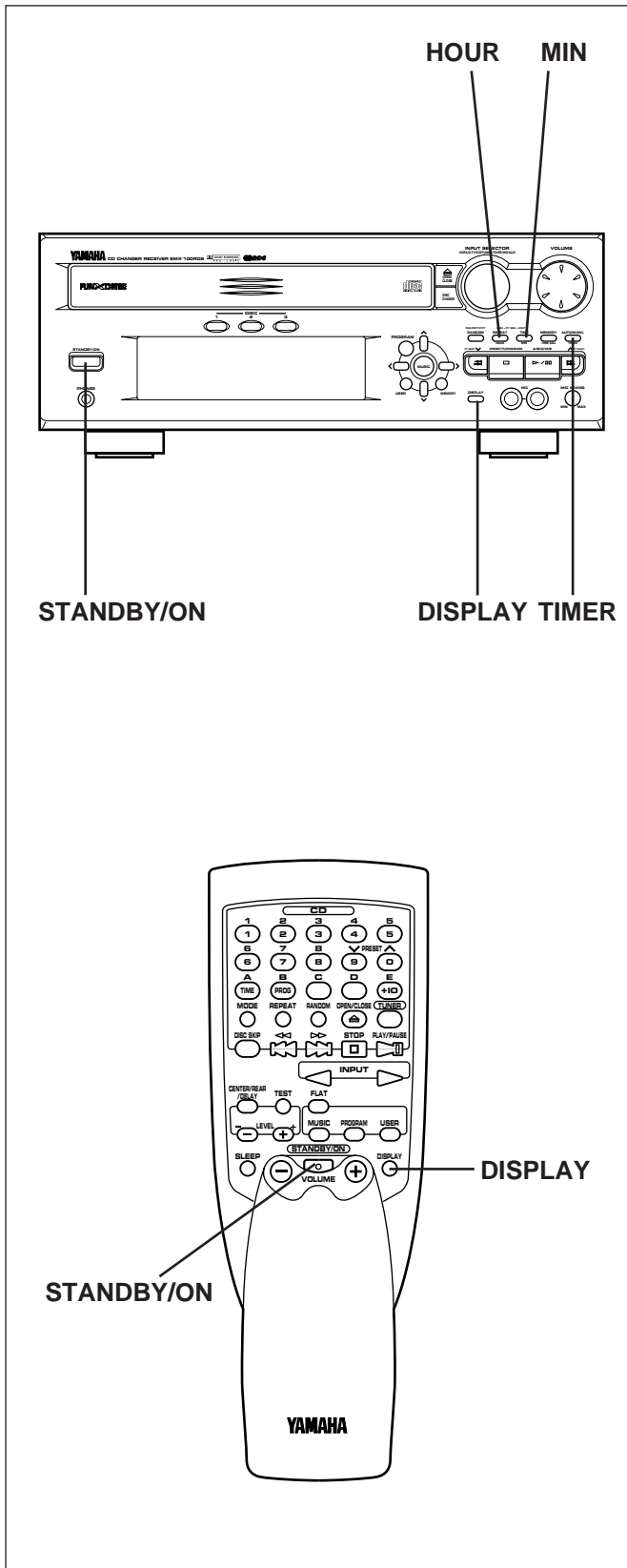

### ③ ON TIME/time setting mode

["ON TIME" appears on the display, and soon it is changed to a time setting mode.]  
Set to the time when you want to begin the timer play by using the HOUR button and the MIN button.

### ④ OFF TIME/time setting mode

["OFF TIME" appears on the display, and soon it is changed to a time setting mode.]  
If necessary, set to the time when you want to finish the timer play (to turn this unit into the standby mode) by using the HOUR button and the MIN button. Even if you do not set the time, it has already been set so that the timer play finishes after 1 hour.

#### Note

The TIMER button functions also in the time (ON TIME or OFF TIME) setting mode. (However, it also turns this unit into the standby mode.)

- 3 Press the TIMER button to complete the timer play setting. (This unit turns into the standby mode.) If you will still use this unit, press the STANDBY/ON switch to turn on this unit.

#### Note

If you continue using this unit after a timer play setting is made, the source set for the timer play will begin playing when the time comes in place of the source played at that time.

### To cancel the timer play setting

After the timer play is finished (while the current time is displayed), press the TIMER button so that "TIMER" goes out from the display.

If it is not canceled, this unit will turn on at the same time every day, so it can be used as an alarm.

\* Unless the AC supply lead is unplugged or there is a power failure for more than 5 minutes, the time set on the timer will be retained until it is reset.

### How to make time setting in the ON TIME or OFF TIME mode

#### For the hour:

Press the HOUR button to change the hour to a higher value. Press and hold to change continuously.

#### For the minute:

Use the MIN button and operate it in the same way as you did to change the hour.

#### Note

You can also change the hour (or the minute) to a lower value by pressing the HOUR button (or the MIN button) with the TIME ADJ button pressed and held.



## HOW TO USE THE BUILT-IN TIMER

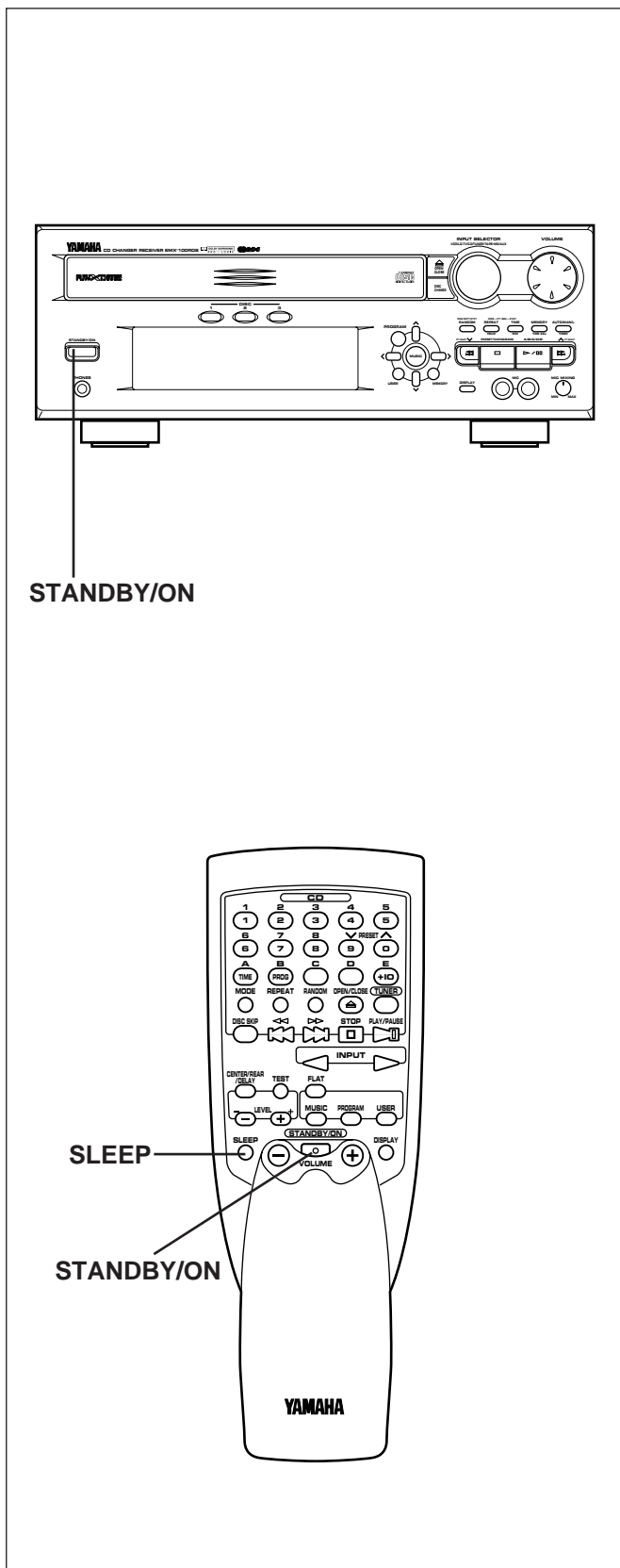

### Sleep timer operation

This unit can be turned into the standby mode automatically.

- 1 Play the desired sound source.
- 2 Press the SLEEP button. "SLEEP" appears on the display, and soon it is replaced by "2h00m".
- 3 Press the SLEEP button repeatedly until the desired sleep time appears on the display. The display will change as described below. [Time is displayed by the hour (h) and the minute (m).]

2h00m → 1h30m → 1h00m → 0h30m  
 OFF SLEEP ←  
 (Sleep timer is off.)

- \* The original display mode will resume about 4 seconds after the selection is made.
- \* The SLEEP indicator will light up to indicate that the sleep timer is on.

- 4 The unit will turn into the standby mode automatically when the selected sleep time passes.

#### To confirm the sleep time setting

Press the SLEEP button once. "SLEEP" appears on the display, and soon it is replaced by the remaining time of the selected sleep time.

#### To change the sleep time

While the SLEEP indicator is illuminated, press the SLEEP button repeatedly until the desired time appears.

#### To stop the sleep timer operation

Press the STANDBY/ON switch, or press the SLEEP button repeatedly until "OFF SLEEP" appears on the display. (The SLEEP indicator will go out.)

### Using the timer and the sleep timer at the same time

You can make a timer play setting so that the timer operates after this unit turns into the standby mode by the operation of the sleep timer.

- 1 Prepare timer play. (See pages 39 to 40)
  - \* Do not turn this unit into the standby mode after the timer setting is finished.

- 2 Press the SLEEP button and set the sleep time.

When the sleep timer operation finishes, the timer begins functioning to turn the source on at the preset time.

#### Note

You cannot use the timer and the sleep timer at the same time in any way other than described here.

## TROUBLESHOOTING

If your unit fails to operate normally, check the following points to determine whether the fault can be corrected by the simple measures suggested. If it cannot, or if the fault is not listed in the SYMPTOM column, disconnect the power cord and contact your authorized YAMAHA dealer or service center for help.

	SYMPTOM	CAUSE	REMEDY
GENERAL	The unit fails to turn on when the STANDBY/ON switch is pressed, or turns into the standby mode suddenly soon after the power is turned on.	AC supply lead is not plugged in.	Plug in the AC supply lead.
	It happens that this unit does not work normally.	There is an influence of strong external noise (lightning, excessive static electricity, etc.) or a misoperation on this unit while using this unit.	Turn this unit into the standby mode and disconnect the AC power cord from the AC outlet. After about 30 seconds have passed, connect the power and operate this unit again.
	The sound suddenly goes off.	The protection circuit has been activated because of short circuit etc.	Turn this unit into the standby mode, and then turn on to reset the protection circuit.
		The SLEEP timer has functioned.	Cancel the SLEEP timer function.
	No sound from one speaker	Loose speaker connections.	Connect properly.
	No sound from speakers.	Speaker connections are not secure.	Secure the connections.
	No sound from the rear speakers.	One rear speaker connection is loose or bad.	Connect it properly.
		The sound output level to the rear speakers is set to minimum.	Raise the sound output level to the rear speakers.
		No sound field program is selected.	Select the appropriate program.
	No sound from the center speaker.	The sound output level to the center speaker is set to minimum.	Raise the sound output level to the center speaker.
		The center channel mode is in PHANTOM mode.	Select NORMAL mode.
		Incorrect sound field program selection. No sound field program is selected.	Select the appropriate program.
	No sound (or no picture) from an external unit connected with this unit.	Incorrect cord connections.	Connect the cords properly. If the problem persists, the cords may be defective.
		Input source selection is not proper.	Make a proper input source selection.
	Can't set timer.	Current time is not set.	Set current time.
	This unit will not operate properly.	The internal microcomputer has been frozen by an external electric shock (lightning, excessive static electricity, etc.) or power supply with low voltage.	Unplug the AC supply lead from the wall AC outlet, and then plug in again after about one minute.
The volume level cannot be increased, or sound is distorted.	The component connected to the REC OUT terminals of this unit is turned off.	Turn the power to the component on.	
The sound is degraded when listening with the headphones connected to the compact disc player or tape deck that are connected with this unit.	This unit is in the standby mode.	Turn the power to this unit on.	
TUNER	Excessive static in FM broadcasts.	Interference from starting motor of nearby car.	Position the FM antenna as high and as far away from nearby roads as possible. Connect using a coaxial cable.
		Interference from thermostat of nearby electrical appliance.	
	Noise increases during stereo broadcasts.	Antenna input is too weak due to obstructions or excessive distance from broadcasting station.	Check antenna connections.
			Install a multi-element type FM antenna if possible.
	Stereo broadcasts are noisy and STEREO indicator blinks on and off.	Insufficient antenna input.	Install an antenna appropriate for the electric field strength of your area.
	Cannot select preset stations.	Preset memory has been erased.	Reprogram memory presets.
	Buzzing or static during AM (LW or MW) broadcasts.	Interference from source such as lightning, fluorescent lights, electric motors or thermostat of nearby electrical appliance.	Problem is difficult to eliminate but can be lessened by grounding MW/LW (AM) loop antenna.
TV or microprocessor is being used nearby.		Move away from TV or microprocessor.	
AM (LW or MW) broadcast sensitivity is poor.	Radio signal is weak or antenna is not properly connected.	Properly connect MW/LW (AM) loop antenna.	
		Change orientation of MW/LW (AM) loop antenna.	
		Install an external MW/LW (AM) antenna.	

## TROUBLESHOOTING

	SYMPTOM	CAUSE	REMEDY
CD PLAYER	Playback will not begin even if disc is loaded.	Disc is upside down.	Load disc label side up.
		Disc is dirty.	Clean disc.
	No sound.	The setting of INPUT SELECTOR is incorrect.	Select the CD player by turning the INPUT SELECTOR.
		Sound stops suddenly (always at same spot).	Disc is dirty.
REMOTE CONTROL	Remote control transmitter doesn't work.	Volume is set too high.	Lower volume.
		Batteries are dead.	Replace batteries.
		Remote control transmitter is too far away or is being used at incorrect angle.	Use within 6 m and 60° radius.
	Direct sunlight or lighting (of an inverter type of fluorescent lamp etc.) is striking the remote control sensor of the main unit.	Change position of the main unit.	
	TV functions strangely when the remote control transmitter is used.	Remote control transmitter is being used near TV set with a remote control sensor.	Relocate this unit away from the TV or cover TV's remote control sensor.

## SPECIFICATIONS

As a part of policy of continuous improvement, YAMAHA reserves the right to make design and specification changes for product improvement without prior notice. The performance specification figures indicated are nominal values of production units.

### ■ Amplifier section

#### Minimum RMS Output Power per Channel

Front L, R	
6 ohms, 1 kHz, 1% THD	65W+65W
Center	
6 ohms, 1 kHz, 1% THD	25W
Rear	
8 ohms, 1 kHz, 1% THD	20W

#### DIN Standard Output Power per Channel

6 ohms, 1 kHz, 1% THD	65W
-----------------------	-----

#### IEC Power

6 ohms, 1 kHz, 0.1% THD	60W
-------------------------	-----

#### Input Sensitivity/Impedance

AUX	170 mV/47 k-ohms
-----	------------------

#### Mic Input Sensitivity/Impedance

MIC	0.5 mV/4.7 k-ohms
-----	-------------------

#### Headphone Output Impedance

	68 ohms
--	---------

#### Total Harmonic Distortion (1 kHz)

AUX to SP OUT (32.5W/6 ohms)	0.08%
------------------------------	-------

#### Signal-to-Noise Ratio (IHF-A Network)

AUX	80 dB
-----	-------

#### Graphic Equalizer Characteristics

(100 Hz, 350 Hz, 1 kHz, 3.5 kHz, 10 kHz)	±10 dB
--	--------

### ■ Video section

Video Signal Level ..... 1 Vp-p/75 ohms

Maximum Input Level ..... 1.5 Vp-p or more

Signal-to-Noise Ratio ..... 50 dB or more

Monitor Out Frequency Response ..5 Hz to 10 MHz, -3 dB

### ■ Tuner section

#### Tuning Range

FM	87.5 to 108.0 MHz
AM (MW)	531 – 1,611 kHz
LW	153 – 288 kHz

#### Usable Sensitivity

FM (75 ohms,DIN, Mono, S/N 26 dB)	1.8 μV
AM (MW)	280 μV/m
LW	560 μV/m

### ■ CD player section

Type ..... 3 DISC Carousel Auto-changer

#### Signal Readout

..... Non-contact, 3-beam semi-conductor laser pick-up

D/A Converter ..... 1-bit DAC

Filter .....8-time oversampling digital filter

Wow and Flutter .....Below measurable limits

### ■ General

Power Supply ..... AC 230V, 50 Hz

Power consumption .....170W

(In the standby mode: 9W)

Dimensions (W x H x D) ..... 435 x 171 x 383 mm

(17-1/8" x 6-3/4" x 15-1/16")

Weight ..... 10.0 kg (22 lbs.)

Accessories.....AM (MW/LW) loop antenna

Indoor FM antenna

Remote control transmitter

Batteries

Specifications are subject to change without notice.

# YAMAHA

---

YAMAHA ELECTRONICS CORPORATION, USA 6660 ORANGETHORPE AVE., BUENA PARK, CALIF. 90620, U.S.A.  
YAMAHA CANADA MUSIC LTD. 135 MILNER AVE., SCARBOROUGH, ONTARIO M1S 3R1, CANADA  
YAMAHA ELECTRONIK EUROPA G.m.b.H. SIEMENSSTR. 22-34, 25462 RELINGEN BEI HAMBURG, F.R. OF GERMANY  
YAMAHA ELECTRONIQUE FRANCE S.A. RUE AMBROISE CROIZAT BP70 CROISSY-BEAUBOURG 77312 MARNE-LA-VALLEE CEDEX02, FRANCE  
YAMAHA ELECTRONICS (UK) LTD. YAMAHA HOUSE, 200 RICKMANSWORTH ROAD WATFORD, HERTS WD1 7JS, ENGLAND  
YAMAHA SCANDINAVIA A.B. J A WETTERGRENS GATA 1, BOX 30053, 400 43 VÄSTRA FRÖLUNDA, SWEDEN  
YAMAHA MUSIC AUSTRALIA PTY, LTD. 17-33 MARKET ST., SOUTH MELBOURNE, 3205 VIC., AUSTRALIA

YAMAHA CORPORATION  
V201710 Printed in Malaysia