

**EN25QA32B (2C)****32 Megabit Serial Flash Memory with 4Kbyte Uniform Sector****FEATURES**

- Single power supply operation
  - Full voltage range: 2.7-3.6 volt
- Serial Interface Architecture
  - SPI Compatible: Mode 0 and Mode 3
- 32 M-bit Serial Flash
  - 32 M-bit/4,096 K-byte/16,384 pages
  - 256 bytes per programmable page
- Standard, Dual or Quad SPI
  - Standard SPI: CLK, CS#, DI, DO
  - Dual SPI: CLK, CS#, DQ<sub>0</sub>, DQ<sub>1</sub>
  - Quad SPI: CLK, CS#, DQ<sub>0</sub>, DQ<sub>1</sub>, DQ<sub>2</sub>, DQ<sub>3</sub>
- High performance
  - 104MHz clock rate for Standard SPI
  - 104MHz clock rate for two data bits
  - 104MHz clock rate for four data bits
- Low power consumption
  - 5mA typical active current
  - 1  $\mu$ A typical power down current
- Uniform Sector Architecture:
  - 1024 sectors of 4-Kbyte
  - 128 blocks of 32-Kbyte
  - 64 blocks of 64-Kbyte
  - Any sector or block can be erased individually
- Software and Permanent Protection:
  - Write Protect all or portion of memory via software
  - The Permanent Protection while PPB=1
- High performance program/erase speed
  - Page program time: 0.5ms typical
  - Sector erase time: 50ms typical
  - 32KB Block erase time 120ms typical
  - 64KB Block erase time 150ms typical
  - Chip erase time: 15 seconds typical
- 3 sets of OTP lockable 512 byte security sectors
- Support Serial Flash Discoverable Parameters (SFDP) signature
- Read Unique ID Number
- Volatile Status Register Bits
- Minimum 100K endurance cycle
- Data retention time 20 years
- Package Options
  - 8 pins SOP 200mil body width
  - 24 balls TFBGA (6x8mm)
  - All Pb-free packages are compliant RoHS, Halogen-Free and REACH.
- Industrial temperature Range

**GENERAL DESCRIPTION**

The device is a 32 Megabit (4,096 K-byte) Serial Flash memory, with enhanced write protection mechanisms. The device supports the standard Serial Peripheral Interface (SPI), and a high performance Dual/Quad output as well as Dual/Quad I/O using SPI pins: Serial Clock, Chip Select, Serial DQ<sub>0</sub>(DI), DQ<sub>1</sub>(DO), DQ<sub>2</sub>(NC) and DQ<sub>3</sub>(NC). SPI clock frequencies of up to 104MHz are supported allowing equivalent clock rates of 208MHz (104MHz x 2) for Dual Output and 416MHz (104MHz x 4) for Quad Output when using the Dual/Quad I/O Fast Read instructions. The memory can be programmed 1 to 256 bytes at a time, using the Page Program instruction.

The device is designed to allow either single Sector/Block at a time or full chip erase operation. The device can be configured to protect part of the memory as the software protected mode. The device can sustain a minimum of 100K program/erase cycles on each sector or block.

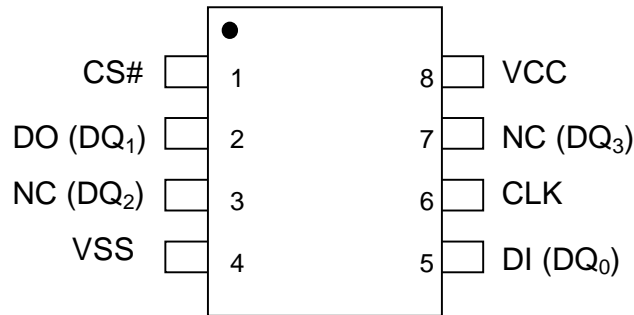
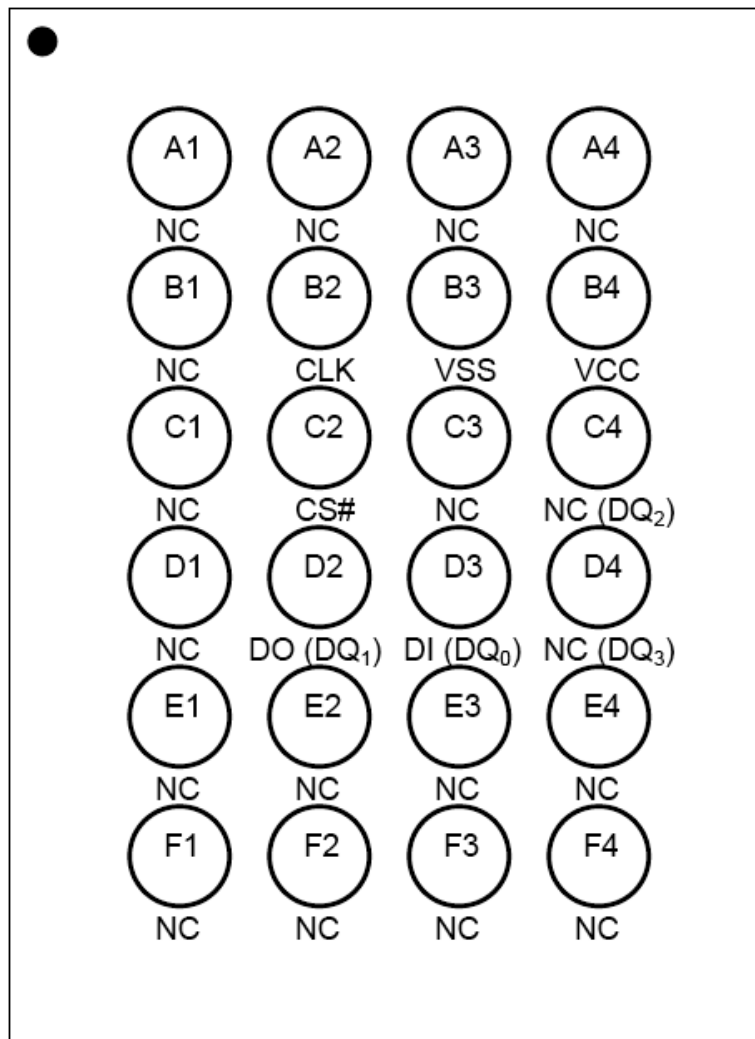
**Figure.1 CONNECTION DIAGRAMS**

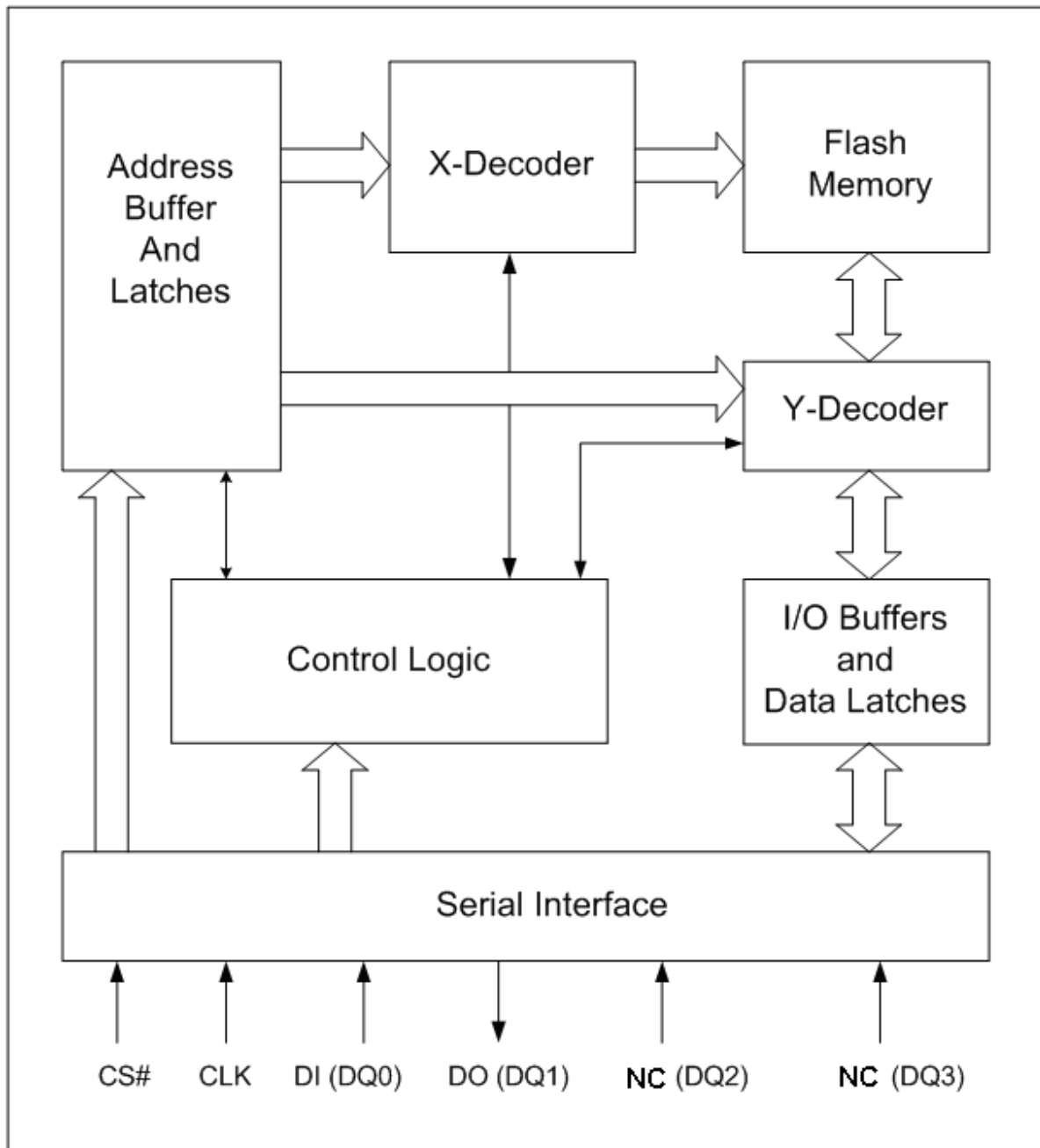
**8 - LEAD SOP / PDIP**
**Top View, Balls Facing Down**

**24 - Ball TFBGA**

**Figure 2. BLOCK DIAGRAM**

**Note:**

1. DQ<sub>0</sub> and DQ<sub>1</sub> are used for Dual and Quad instructions.
2. DQ<sub>0</sub> ~ DQ<sub>3</sub> are used for Quad instructions.

**Table 1. Pin Names**

<b>Symbol</b>	<b>Pin Name</b>
CLK	Serial Clock Input
DI (DQ <sub>0</sub> )	Serial Data Input (Data Input Output 0) <sup>*1</sup>
DO (DQ <sub>1</sub> )	Serial Data Output (Data Input Output 1) <sup>*1</sup>
CS#	Chip Select
NC (DQ <sub>2</sub> )	NC (Data Input Output 2) <sup>*2</sup>
NC (DQ <sub>3</sub> )	NC (Data Input Output 3) <sup>*2</sup>
Vcc	Supply Voltage (2.7-3.6V)
Vss	Ground
NC	No Connect

Note:

1. DQ<sub>0</sub> and DQ<sub>1</sub> are used for Dual and Quad instructions.
2. DQ<sub>2</sub> ~ DQ<sub>3</sub> are used for Quad instructions.

## **SIGNAL DESCRIPTION**

### **Serial Data Input, Output and IOs (DI, DO and DQ<sub>0</sub>, DQ<sub>1</sub>, DQ<sub>2</sub>, DQ<sub>3</sub>)**

The device support standard SPI, Dual SPI and Quad SPI operation. Standard SPI instructions use the unidirectional DI (input) pin to serially write instructions, addresses or data to the device on the rising edge of the Serial Clock (CLK) input pin. Standard SPI also uses the unidirectional DO (output) to read data or status from the device on the falling edge CLK.

Dual and Quad SPI instruction use the bidirectional IO pins to serially write instruction, addresses or data to the device on the rising edge of CLK and read data or status from the device on the falling edge of CLK.

### **Serial Clock (CLK)**

The SPI Serial Clock Input (CLK) pin provides the timing for serial input and output operations. ("See SPI Mode")

### **Chip Select (CS#)**

The SPI Chip Select (CS#) pin enables and disables device operation. When CS# is high the device is deselected and the Serial Data Output (DO, or DQ<sub>0</sub>, DQ<sub>1</sub>, DQ<sub>2</sub> and DQ<sub>3</sub>) pins are at high impedance. When deselected, the devices power consumption will be at standby levels unless an internal erase, program or status register cycle is in progress. When CS# is brought low the device will be selected, power consumption will increase to active levels and instructions can be written to and data read from the device. After power-up, CS# must transition from high to low before a new instruction will be accepted.



## **MEMORY ORGANIZATION**

The memory is organized as:

- 4,194,304 bytes
- Uniform Sector Architecture
  - 128 blocks of 32-Kbyte
  - 64 blocks of 64-Kbyte
  - 1,024 sectors of 4-Kbyte
- 16,384 pages (256 bytes each)

Each page can be individually programmed (bits are programmed from 1 to 0). The device is Sector, Block or Chip Erasable but not Page Erasable.



Table 2. Uniform Block Sector Architecture

64K Block	32K Block	Sector	Address range	
63	127	1023	3FF000h	3FFFFFFh
		⋮	⋮	⋮
	126	1008	3F0000h	3F0FFFFh
62	125	1007	3EF000h	3EFFFFFFh
		⋮	⋮	⋮
	124	992	3E0000h	3E0FFFFh
61	123	991	3DF000h	3DFFFFFFh
		⋮	⋮	⋮
	122	976	3D0000h	3D0FFFFh
⋮	⋮	⋮	⋮	⋮
50	101	815	32F000h	32FFFFFFh
		⋮	⋮	⋮
	100	800	320000h	320FFFFh
49	99	799	31F000h	31FFFFFFh
		⋮	⋮	⋮
	98	784	310000h	310FFFFh
48	97	783	30F000h	30FFFFFFh
		⋮	⋮	⋮
	96	768	300000h	300FFFFh

64K Block	32K Block	Sector	Address range	
47	95	767	2FF000h	2FFFFFFh
		⋮	⋮	⋮
	94	752	2F0000h	2F0FFFFh
46	93	751	2EF000h	2EFFFFFFh
		⋮	⋮	⋮
	92	736	2E0000h	2E0FFFFh
45	91	735	2DF000h	2DFFFFFFh
		⋮	⋮	⋮
	90	720	2D0000h	2D0FFFFh
⋮	⋮	⋮	⋮	⋮
34	69	559	22F000h	22FFFFFFh
		⋮	⋮	⋮
	68	544	220000h	220FFFFh
33	67	543	21F000h	21FFFFFFh
		⋮	⋮	⋮
	66	528	210000h	210FFFFh
32	65	527	20F000h	20FFFFFFh
		⋮	⋮	⋮
	64	512	200000h	200FFFFh

64K Block	32K Block	Sector	Address range	
31	63	511	01FF000h	01FFFFFFh
		⋮	⋮	⋮
	62	496	01F0000h	01F0FFFFh
30	61	495	01EF000h	01EFFFFFFh
		⋮	⋮	⋮
	60	480	01E0000h	01E0FFFFh
29	59	479	01DF000h	01DFFFFFFh
		⋮	⋮	⋮
	58	464	01D0000h	01D0FFFFh
⋮	⋮	⋮	⋮	⋮
18	37	303	012F000h	012FFFFFFh
		⋮	⋮	⋮
	36	288	0120000h	0120FFFFh
17	35	287	011F000h	011FFFFFFh
		⋮	⋮	⋮
	34	272	0110000h	0110FFFFh
16	33	271	010F000h	010FFFFFFh
		⋮	⋮	⋮
	32	256	0100000h	0100FFFFh

64K Block	32K Block	Sector	Address range	
15	31	255	00FF000h	00FFFFFFh
		⋮	⋮	⋮
	30	240	00F0000h	00F0FFFFh
14	29	239	00EF000h	00EFFFFFFh
		⋮	⋮	⋮
	28	224	00E0000h	00E0FFFFh
13	27	223	00DF000h	00DFFFFFFh
		⋮	⋮	⋮
	26	208	00D0000h	00D0FFFFh
⋮	⋮	⋮	⋮	⋮
2	5	47	002F000h	002FFFFFFh
		⋮	⋮	⋮
	4	32	0020000h	0020FFFFh
1	3	31	001F000h	001FFFFFFh
		⋮	⋮	⋮
	2	16	0010000h	0010FFFFh
0	1	15	000F000h	000FFFFFFh
		⋮	⋮	⋮
	0	0	0000000h	0000FFFFh

## OPERATING FEATURES

### Standard SPI Modes

The device is accessed through a SPI compatible bus consisting of four signals: Serial Clock (CLK), Chip Select (CS#), Serial Data Input (DI) and Serial Data Output (DO). Both SPI bus operation Modes 0 (0, 0) and 3 (1, 1) are supported. The primary difference between Mode 0 and Mode 3, as shown in Figure 3, concerns the normal state of the CLK signal when the SPI bus master is in standby and data is not being transferred to the Serial Flash. For Mode 0 the CLK signal is normally low. For Mode 3 the CLK signal is normally high. In either case data input on the DI pin is sampled on the rising edge of the CLK. Data output on the DO pin is clocked out on the falling edge of CLK.

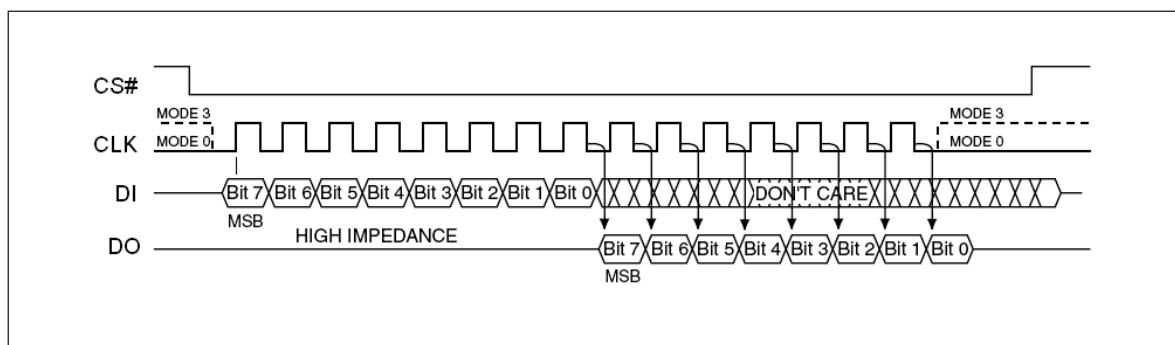

**Figure 3. SPI Modes**

### Dual SPI Instruction

The device supports Dual SPI operation when using the “Dual Output Fast Read and Dual I/O Fast Read” (3Bh and BBh) instructions. These instructions allow data to be transferred to or from the Serial Flash memory at two to three times the rate possible with the standard SPI. The Dual Read instructions are ideal for quickly downloading code from Flash to RAM upon power-up (code-shadowing) or for application that cache code-segments to RAM for execution. The Dual output feature simply allows the SPI input pin to also serve as an output during this instruction. When using Dual SPI instructions the DI and DO pins become bidirectional I/O pins; DQ<sub>0</sub> and DQ<sub>1</sub>. All other operations use the standard SPI interface with single output signal.

### Quad I/O SPI Modes

The device supports Quad input / output operation when using the Quad I/O Fast Read (EBh). This instruction allows data to be transferred to or from the Serial Flash memory at four to six times the rate possible with the standard SPI. The Quad Read instruction offer a significant improvement in continuous and random access transfer rates allowing fast code-shadowing to RAM or for application that cache code-segments to RAM for execution. When using Quad SPI instruction the DI and DO pins become bidirectional I/O pins; DQ<sub>0</sub> and DQ<sub>1</sub>, and the NC pins become DQ<sub>2</sub> and DQ<sub>3</sub> respectively.

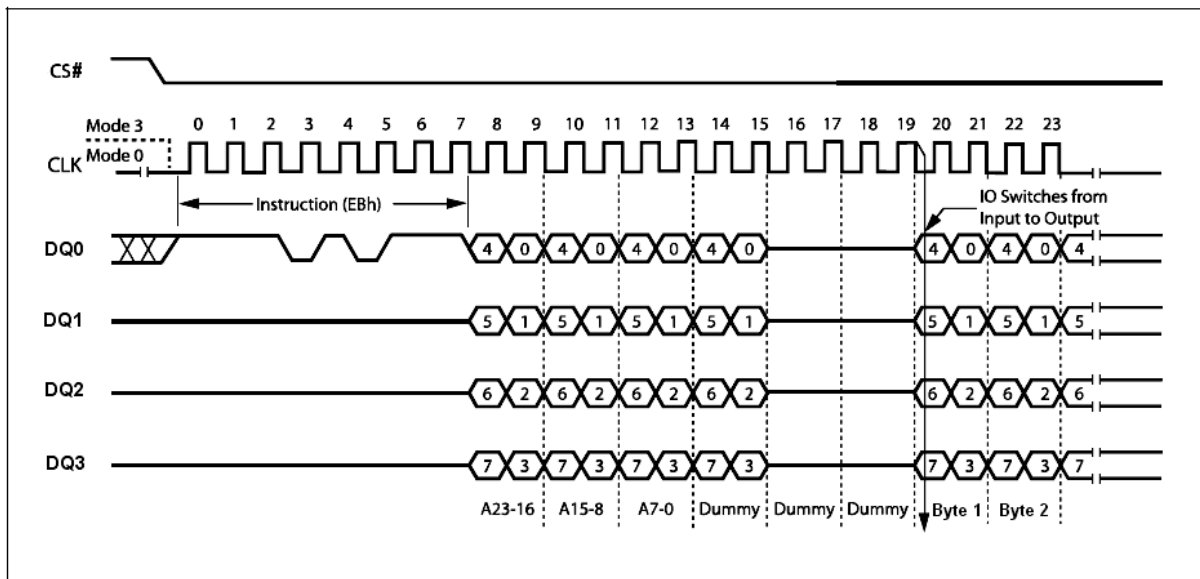
**Figure 4. Quad I/O SPI Modes**
**Full Quad SPI Modes (QPI)**

The device also supports Full Quad SPI Mode (QPI) function while using the Enable Quad Peripheral Interface mode (EQPI) (38h). When using Quad SPI instruction the DI and DO pins become bidirectional I/O pins; DQ<sub>0</sub> and DQ<sub>1</sub>, and the NC pins become DQ<sub>2</sub> and DQ<sub>3</sub> respectively.

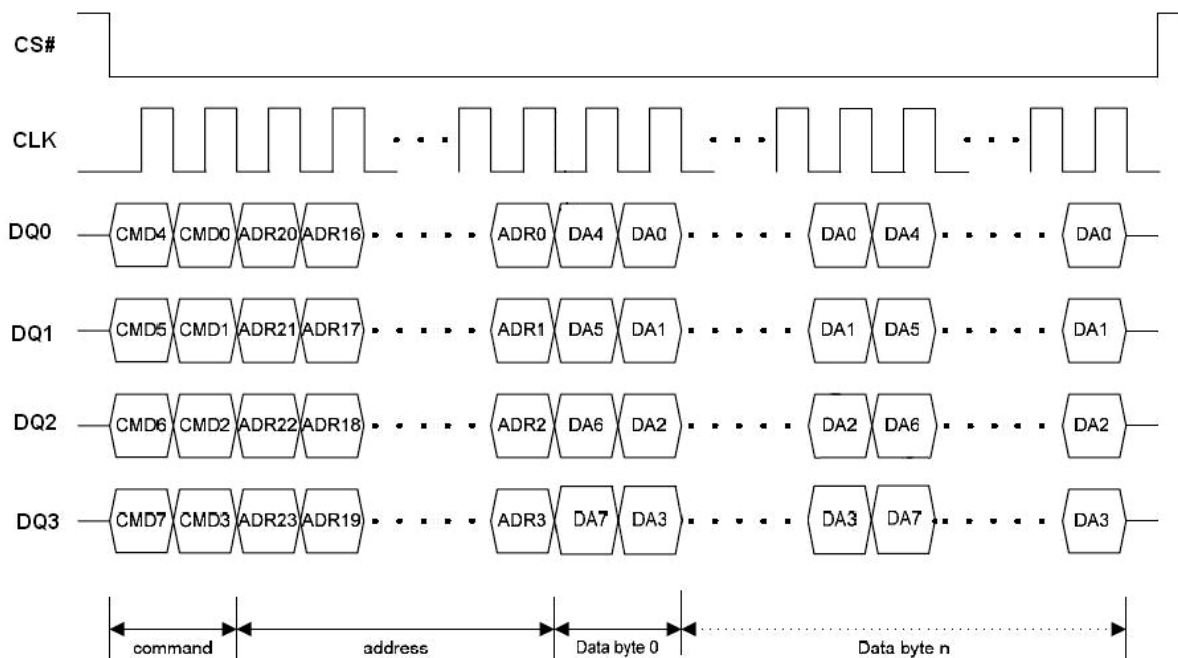
**Figure 5. Full Quad SPI Modes**





### Page Programming

To program one data byte, two instructions are required: Write Enable (WREN), which is one byte, and a Page Program (PP) or Quad Input Page Program (QPP) sequence, which consists of four bytes plus data. This is followed by the internal Program cycle (of duration  $t_{PP}$ ).

To spread this overhead, the Page Program (PP) or Quad Input Page Program (QPP) instruction allows up to 256 bytes to be programmed at a time (changing bits from 1 to 0) provided that they lie in consecutive addresses on the same page of memory.

### Sector Erase, Half Block Erase, Block Erase and Chip Erase

The Page Program (PP) or Quad Input Page Program (QPP) instruction allows bits to be reset from 1 to 0. Before this can be applied, the bytes of memory need to have been erased to all 1s (FFh). This can be achieved a sector at a time, using the Sector Erase (SE) instruction, half a block at a time using the Half Block Erase (HBE) instruction, a block at a time using the Block Erase (BE) instruction or throughout the entire memory, using the Chip Erase (CE) instruction. This starts an internal Erase cycle (of duration  $t_{SE}$ ,  $t_{HBE}$ ,  $t_{BE}$  or  $t_{CE}$ ). The Erase instruction must be preceded by a Write Enable (WREN) instruction.

### Polling During a Write, Program or Erase Cycle

A further improvement in the time to Write Status Register (WRSR), Program (PP, QPP) or Erase (SE, HBE, BE or CE) can be achieved by not waiting for the worst case delay ( $t_W$ ,  $t_{PP}$ ,  $t_{SE}$ ,  $t_{HBE}$ ,  $t_{BE}$  or  $t_{CE}$ ). The Write In Progress (WIP) bit is provided in the Status Register so that the application program can monitor its value, polling it to establish when the previous Write cycle, Program cycle or Erase cycle is complete.

### Active Power, Stand-by Power and Deep Power-Down Modes

When Chip Select (CS#) is Low, the device is enabled, and in the Active Power mode. When Chip Select (CS#) is High, the device is disabled, but could remain in the Active Power mode until all internal cycles have completed (Program, Erase, and Write Status Register). The device then goes into the Stand-by Power mode. The device consumption drops to  $I_{CC1}$ .

The Deep Power-down mode is entered when the specific instruction (the Enter Deep Power-down Mode (DP) instruction) is executed. The device consumption drops further to  $I_{CC2}$ . The device remains in this mode until another specific instruction (the Release from Deep Power-down Mode and Read Device ID (RDI) instruction) is executed.

All other instructions are ignored while the device is in the Deep Power-down mode. This can be used as an extra software protection mechanism, when the device is not in active use, to protect the device from inadvertent Write, Program or Erase instructions.

### Write Protection

Applications that use non-volatile memory must take into consideration the possibility of noise and other adverse system conditions that may compromise data integrity. To address this concern the device provides the following data protection mechanisms:

- Power-On Reset and an internal timer ( $t_{PUW}$ ) can provide protection against inadvertent changes while the power supply is outside the operating specification.
- Program, Erase and Write Status Register instructions are checked that they consist of a number of clock pulses that is a multiple of eight, before they are accepted for execution.
- All instructions that modify data must be preceded by a Write Enable (WREN) instruction to set the Write Enable Latch (WEL) bit. This bit is returned to its reset state by the following events:
  - Power-up
  - Write Disable (WRDI) instruction completion or Write Status Register (WRSR) instruction completion or Page Program (PP), Quad Input Page Program (QPP) instruction completion or Sector Erase (SE) instruction completion or Half Block Erase (HBE) / Block Erase (BE) instruction completion or Chip Erase (CE) instruction completion
- The Block Protect (BP3, BP2, BP1, BP0) bits allow part of the memory to be configured as read-only. This is the Software Protected Mode (SPM).
- Once Permanent Protection Bit (PPB) has been programmed with “1” by WRSR command (PPB=1), all the status of Block Protect (BP3, BP2, BP1, BP0) bits and the SPL0, SPL1, SPL2 bits can't be changed again, and the non-volatile bits of the Status Register (PPB, BP3, BP2, BP1, BP0) become read-only bits. This is Permanent Protection Mode.



- In addition to the low power consumption feature, the Deep Power-down mode offers extra software protection from inadvertent Write, Program and Erase instructions, as all instructions are ignored except one particular instruction (the Release from Deep Power-down instruction).

**Table 3. Protected Area Sizes Sector Organization**

Status Register Content					Memory Content			
T/B Bit	SR5 Bit	SR4 Bit	SR3 Bit	SR2 Bit	Protect Areas	Addresses	Density(KB)	Portion
0	0	0	0	0	None	None	None	None
0	0	0	0	1	Block 63	3F0000h-3FFFFFFh	64KB	Upper 1/64
0	0	0	1	0	Block 62 to 63	3E0000h-3FFFFFFh	128KB	Upper 2/64
0	0	0	1	1	Block 60 to 63	3C0000h-3FFFFFFh	256KB	Upper 4/64
0	0	1	0	0	Block 56 to 63	380000h-3FFFFFFh	512KB	Upper 8/64
0	0	1	0	1	Block 48 to 63	300000h-3FFFFFFh	1024KB	Upper 16/64
0	0	1	1	0	Block 32 to 63	200000h-3FFFFFFh	2048KB	Upper 32/64
0	0	1	1	1	Block 16 to 63	100000h-3FFFFFFh	3072KB	Upper 48/64
0	1	0	0	0	Block 8 to 63	080000h-3FFFFFFh	3584KB	Upper 56/64
0	1	0	0	1	Block 4 to 63	040000h-3FFFFFFh	3840KB	Upper 60/64
0	1	0	1	0	Block 2 to 63	020000h-3FFFFFFh	3968KB	Upper 62/64
0	1	0	1	1	Block 1 to 63	010000h-3FFFFFFh	4032KB	Upper 63/64
0	1	1	0	0	All	000000h-3FFFFFFh	4096KB	All
0	1	1	0	1	All	000000h-3FFFFFFh	4096KB	All
0	1	1	1	0	All	000000h-3FFFFFFh	4096KB	All
0	1	1	1	1	All	000000h-3FFFFFFh	4096KB	All
1	0	0	0	0	None	None	None	None
1	0	0	0	1	Block 0	000000h-00FFFFh	64KB	Lower 1/64
1	0	0	1	0	Block 0 to 1	000000h-01FFFFh	128KB	Lower 2/64
1	0	0	1	1	Block 0 to 3	000000h-03FFFFh	256KB	Lower 4/64
1	0	1	0	0	Block 0 to 7	000000h-07FFFFh	512KB	Lower 8/64
1	0	1	0	1	Block 0 to 15	000000h-0FFFFh	1024KB	Lower 16/64
1	0	1	1	0	Block 0 to 31	000000h-1FFFFh	2048KB	Lower 32/64
1	0	1	1	1	Block 0 to 47	000000h-2FFFFh	3072KB	Lower 48/64
1	1	0	0	0	Block 0 to 55	000000h-37FFFFh	3584KB	Lower 56/64
1	1	0	0	1	Block 0 to 59	000000h-3BFFFFh	3840KB	Lower 60/64
1	1	0	1	0	Block 0 to 61	000000h-3DFFFFh	3968KB	Lower 62/64
1	1	0	1	1	Block 0 to 62	000000h-3EFFFFh	4032KB	Lower 63/64
1	1	1	0	0	All	000000h-3FFFFFFh	4096KB	All
1	1	1	0	1	All	000000h-3FFFFFFh	4096KB	All
1	1	1	1	0	All	000000h-3FFFFFFh	4096KB	All
1	1	1	1	1	All	000000h-3FFFFFFh	4096KB	All

**Enable Boot Lock**

The Enable Boot Lock feature enables user to lock the 64KB block/sector on the top/bottom of the device for protection. This feature is activated by issue Writing Status Register (05h) after entering OTP mode.

The bits' definitions are described in the following table.



Table 4. The Enable Boot Lock feature

Register	Type	Description	Function
SR6	non-volatile / volatile	Enable 64KB-block/Sector Boot lock	0 (default)
			1 : 64KB-Block/Sector lock selection
SR4	OTP/ volatile	64KB-Block/Sector switch	0 : 64KB-Block (default)
			1 : Sector
SR3	OTP/ volatile	Top/Bottom switch	0 : Top (default)
			1 : Bottom

## INSTRUCTIONS

All instructions, addresses and data are shifted in and out of the device, most significant bit first. Serial Data Input (DI) is sampled on the first rising edge of Serial Clock (CLK) after Chip Select (CS#) is driven Low. Then, the one-byte instruction code must be shifted in to the device, most significant bit first, on Serial Data Input (DI), each bit being latched on the rising edges of Serial Clock (CLK).

The instruction set is listed in Table 5. Every instruction sequence starts with a one-byte instruction code. Depending on the instruction, this might be followed by address bytes, or by data bytes, or by both or none. Chip Select (CS#) must be driven High after the last bit of the instruction sequence has been shifted in. In the case of a Read Data Bytes (READ), Read Data Bytes at Higher Speed (Fast\_Read), Dual Output Fast Read (3Bh), Dual I/O Fast Read (BBh), Quad Output Fast Read (6Bh), Quad Input/Output FAST\_READ (EBh), Read Status Register (RDSR) or Release from Deep Power-down, and Read Device ID (RDI) instruction, the shifted-in instruction sequence is followed by a data-out sequence. Chip Select (CS#) can be driven High after any bit of the data-out sequence is being shifted out.

In the case of a Page Program (PP), Quad Input Page Program (QPP), Sector Erase (SE), Half Block Erase (HBE), Block Erase (BE), Chip Erase (CE), Write Status Register (WRSR), Volatile Status Register Write Enable, Write Enable (WREN), Write Disable (WRDI) or Deep Power-down (DP) instruction, Chip Select (CS#) must be driven High exactly at a byte boundary, otherwise the instruction is rejected, and is not executed. That is, Chip Select (CS#) must be driven High when the number of clock pulses after Chip Select (CS#) being driven Low is an exact multiple of eight. For Page Program, if at any time the input byte is not a full byte, nothing will happen and WEL will not be reset.

**In the case of multi-byte commands of Page Program (PP), Quad Input Page Program (QPP) and Release from Deep Power Down (RES ) minimum number of bytes specified has to be given, without which, the command will be ignored.**

**In the case of Page Program, if the number of byte after the command is less than 4 (at least 1 data byte), it will be ignored too. In the case of SE, HBE and BE, exact 24-bit address is a must, any less or more will cause the command to be ignored.**

All attempts to access the memory array during a Write Status Register cycle, Program cycle or Erase cycle are ignored, and the internal Write Status Register cycle, Program cycle or Erase cycle continues unaffected.



Table 5A. Instruction Set

Instruction Name	Byte 1 Code	Byte 2	Byte 3	Byte 4	Byte 5	Byte 6	n-Bytes
EQPI	38h						
RSTQIO <sup>(1)</sup> Release Quad I/O or Fast Read Enhanced Mode	FFh						
RSTEN	66h						
RST <sup>(2)</sup>	99h						
Write Enable	06h						
Volatile Status Register Write Enable <sup>(3)</sup>	50h						
Write Disable / Exit OTP mode	04h						
Read Status Register (RDSR)	05h	(SR7-SR0) <sup>(4)</sup>					continuous <sup>(5)</sup>
Write Status Register	01h	SR7-SR0					
Page Program	02h	A23-A16	A15-A8	A7-A0	D7-D0	Next byte	continuous
Quad Input Page Program	32h	A23-A16	A15-A8	A7-A0	(D7-D0, ...) <sup>(6)</sup>		(one byte per 2 clocks, continuous)
Sector Erase	20h	A23-A16	A15-A8	A7-A0			
32KB Half Block Erase (HBE)	52h	A23-A16	A15-A8	A7-A0			
64KB Block Erase	D8h	A23-A16	A15-A8	A7-A0			
Chip Erase	C7h/ 60h						
Deep Power-down	B9h						
Release from Deep Power-down, and read Device ID	ABh	dummy	dummy	dummy	(ID7-ID0)		(7)
Release from Deep Power-down							
Manufacturer/ Device ID	90h	dummy	dummy	00h	(M7-M0)	(ID7-ID0)	(8)
				01h	(ID7-ID0)	(M7-M0)	
Read Identification	9Fh	(M7-M0)	(ID15-ID8)	(ID7-ID0)	(9)		
Enter OTP mode	3Ah						
Read SFDP mode and Unique ID Number	5Ah	A23-A16	A15-A8	A7-A0	dummy	(D7-D0)	(Next Byte) continuous

Notes:

1. Device accepts eight-clocks command in Standard SPI mode, or two-clocks command in Quad SPI mode
2. RST command only executed if RSTEN command is executed first. Any intervening command will disable Reset.
3. Volatile Status Register Write Enable command must precede WRSR command without any intervening commands to write data to Volatile Status Register
4. Data bytes are shifted with Most Significant Bit first. Byte fields with data in parenthesis "( )" indicate data being read from the device on the DO pin
5. The Status Register contents will repeat continuously until CS# terminate the instruction
6. Quad Data  
 DQ<sub>0</sub> = (D4, D0, ..... )  
 DQ<sub>1</sub> = (D5, D1, ..... )  
 DQ<sub>2</sub> = (D6, D2, ..... )  
 DQ<sub>3</sub> = (D7, D3, ..... )
7. The Device ID will repeat continuously until CS# terminates the instruction
8. The Manufacturer ID and Device ID bytes will repeat continuously until CS# terminates the instruction. 00h on Byte 4 starts with MID and alternate with DID, 01h on Byte 4 starts with DID and alternate with MID
9. (M7-M0) : Manufacturer, (ID15-ID8) : Memory Type, (ID7-ID0) : Memory Capacity



**Table 5B. Instruction Set (Read Instruction)**

Instruction Name	OP Code	Address bits	Dummy bits / Clocks (Default)	Data Out	Remark
Read Data	03h	24 bits	0	(D7-D0, ...)	(Next Byte) continuous
Fast Read	0Bh	24 bits	8 bits / 8 clocks	(D7-D0, ...)	(Next Byte) continuous
Dual Output Fast Read	3Bh	24 bits	8 bits / 8 clocks	(D7-D0, ...)	(one byte Per 4 clocks, continuous)
Dual I/O Fast Read	BBh	24 bits	8 bits / 4 clocks	(D7-D0, ...)	(one byte Per 4 clocks, continuous)
Quad Output Fast Read	6Bh	24 bits	8 bits / 8 clocks	(D7-D0, ...)	(one byte Per 2 clocks, continuous)
Quad I/O Fast Read	EBh	24 bits	24 bits / 6 clocks	(D7-D0, ...)	(one byte per 2 clocks, continuous)

**Table 5C. Instruction Set (Read Instruction support mode and dummy cycle setting)**

Instruction Name	OP Code	Start From SPI/QPI		Dummy Cycle	
		SPI	QPI	SPI	QPI
Read Data	03h	Yes	No	N/A	N/A
Fast Read	0Bh	Yes	Yes	8 clocks	6 clocks
Dual Output Fast Read	3Bh	Yes	No	8 clocks	N/A
Dual I/O Fast Read	BBh	Yes	No	4 clocks	N/A
Quad Output Fast Read	6Bh	Yes	No	8 clocks	N/A
Quad I/O Fast Read	EBh	Yes	Yes	6 clocks	6 clocks
Quad Input/Output Fast Read Enhance Performance Mode	EBh	Yes	Yes	6 clocks ( 2 clocks are performance enhance indicator)	6 clocks ( 2 clocks are performance enhance indicator)

Note:

1. 'Start From SPI/QPI' means if this command is initiated from SPI or QPI mode.

**Table 6. Manufacturer and Device Identification**

OP Code	(M7-M0)	(ID15-ID0)	(ID7-ID0)
ABh			15h
90h	1Ch		15h
9Fh	1Ch	6016h	

**Enable Quad Peripheral Interface mode (EQPI) (38h)**

The Enable Quad Peripheral Interface mode (EQPI) instruction will enable the flash device for Quad SPI bus operation. Upon completion of the instruction, all instructions thereafter will be 4-bit multiplexed input/output until a power cycle or “Reset Quad I/O instruction“ instruction, as shown in Figure 6. The device did not support the Read Data Bytes (READ) (03h), Dual Output Fast Read (3Bh) and Dual Input/Output FAST\_READ (BBh) and Quad Input Page Program (32h) and Quad Output Fast Read (6Bh) modes while the Enable Quad Peripheral Interface mode (EQPI) (38h) turns on.

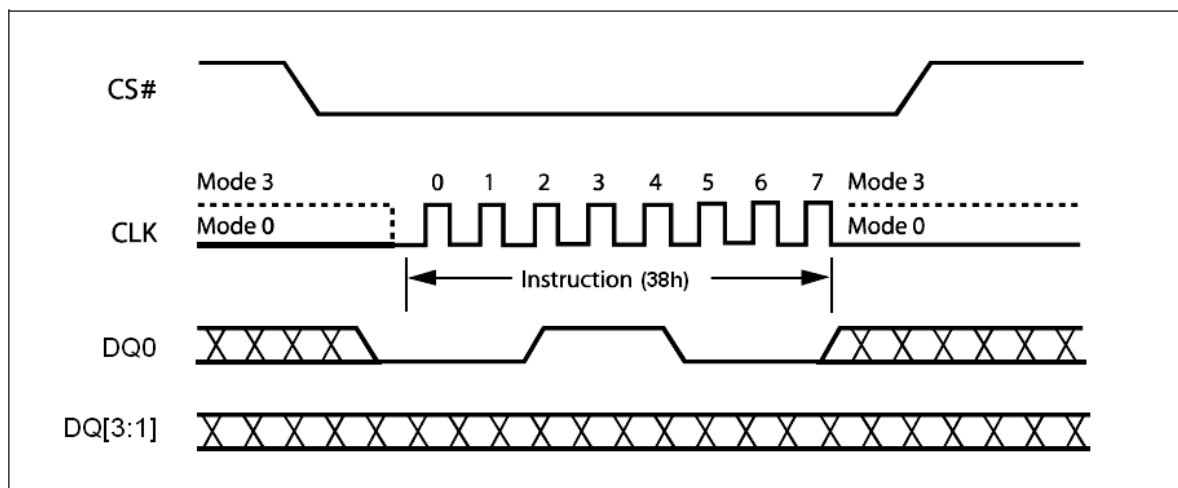

**Figure 6. Enable Quad Peripheral Interface mode Sequence Diagram**

**Reset Quad I/O (RSTQIO) or Release Quad I/O Fast Read Enhancement Mode (FFh)**

The Reset Quad I/O instruction resets the device to 1-bit Standard SPI operation. To execute a Reset Quad I/O operation, the host drives CS# low, sends the Reset Quad I/O command cycle (FFh) then, drives CS# high. This command can't be used in Standard SPI mode.

User also can use the 0xFFh command to release the Quad I/O Fast Read Enhancement Mode. The detail description, please see the Quad I/O Fast Read Enhancement Mode section.

**Note:**

If the system is in the Quad I/O Fast Read Enhance Mode in QPI Mode, it is necessary to execute 0xFFh command by two times. The first 0xFFh command is to release Quad I/O Fast Read Enhance Mode, and the second 0xFFh command is to release QPI Mode.

**Reset-Enable (RSTEN) (66h) and Reset (RST) (99h)**

The Reset operation is used as a system (software) reset that puts the device in normal operating Ready mode. This operation consists of two commands: Reset-Enable (RSTEN) and Reset (RST).

To reset the device the host drives CS# low, sends the Reset-Enable command (66h), and drives CS# high. Next, the host drives CS# low again, sends the Reset command (99h), and drives CS# high. The Reset operation requires the Reset-Enable command followed by the Reset command. Any command other than the Reset command after the Reset-Enable command will disable the Reset-Enable.

A successful command execution will reset the Status register to data = 00h, see Figure 7 for SPI Mode and Figure 7.1 for QPI Mode. A device reset during an active Program or Erase operation aborts the operation, which can cause the data of the targeted address range to be corrupted or lost. Depending on the prior operation, the reset timing may vary. Recovery from a Write operation requires more software latency time ( $t_{SR}$ ) than recovery from other operations. Please Figure 7.2.

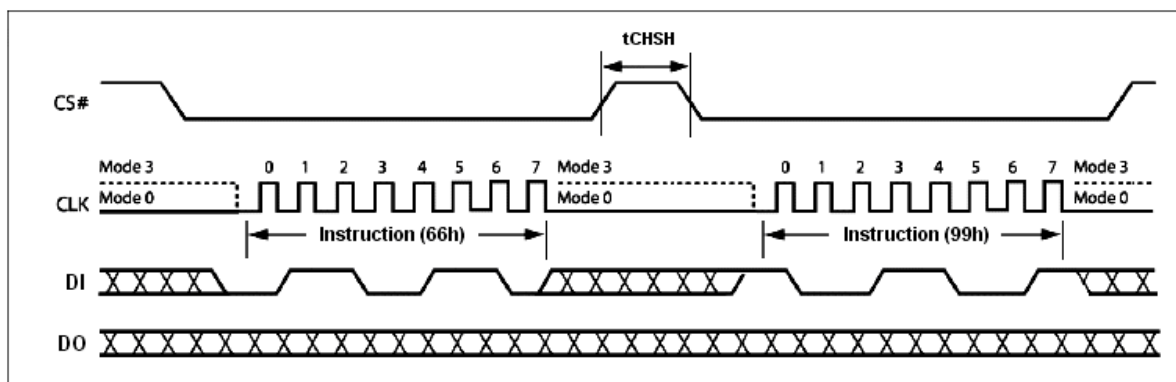
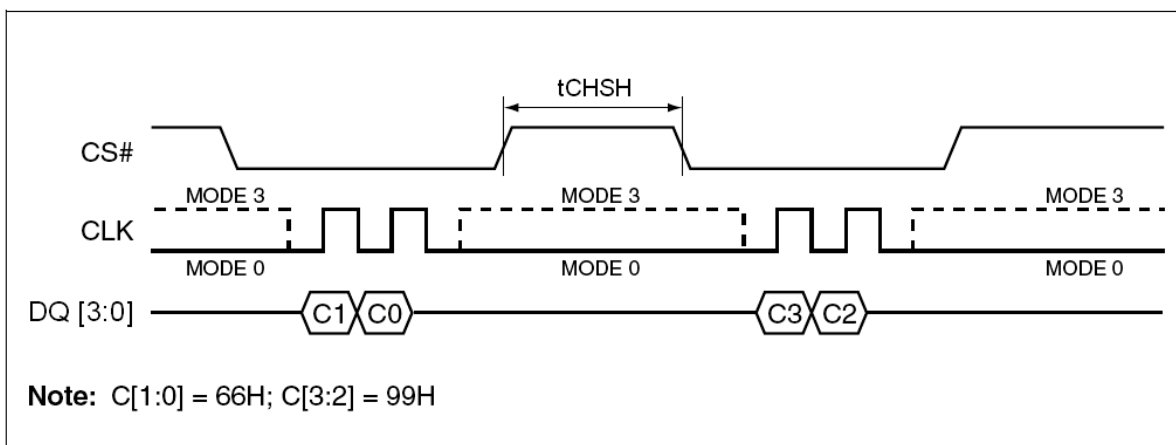
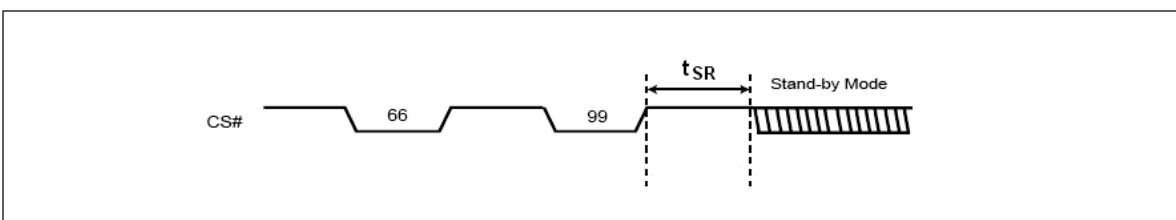
**Figure 7. Reset-Enable and Reset Sequence Diagram**

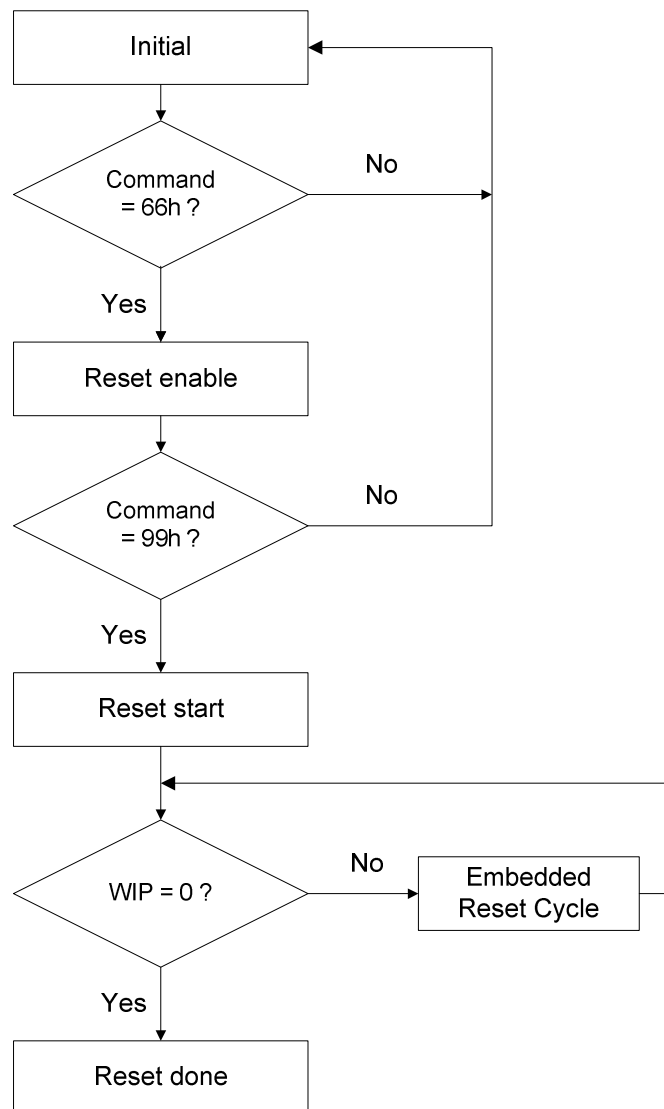
**Figure 7.1 Reset-Enable and Reset Sequence Diagram in QPI Mode**

**Figure 7.2 Software Reset Recovery**

**Software Reset Flow**

**Note:**

1. Reset-Enable (RSTEN) (66h) and Reset (RST) (99h) commands need to match standard SPI or QPI (Full Quad) mode.
2. Continue (Enhance) EB mode need to use quad Reset-Enable (RSTEN) (66h) and quad Reset (RST) (99h) commands.
3. If user is not sure it is in SPI or Quad mode, we suggest to execute sequence as follows:  
Quad Reset-Enable (RSTEN) (66h) -> Quad Reset (RST) (99h) -> SPI Reset-Enable (RSTEN) (66h)  
-> SPI Reset (RST) (99h) to reset.
4. The reset command could be executed during embedded program and erase process, QPI mode and Continue EB mode to back to SPI mode.
5. This flow cannot release the device from Deep power down mode.
6. The Status Register Bit will reset to default value after reset done.
7. If user reset device during erase, the embedded reset cycle software reset latency will take about 28us in worst case.
8. User can't do software reset command while doing 4K/32K erase operation.



**Write Enable (WREN) (06h)**

The Write Enable (WREN) instruction (Figure 8) sets the Write Enable Latch (WEL) bit. The Write Enable Latch (WEL) bit must be set prior to every Page Program (PP), Sector Erase (SE), Half Block Erase (HBE), Block Erase (BE), Chip Erase (CE) and Write Status Register (WRSR) instruction.

The Write Enable (WREN) instruction is entered by driving Chip Select (CS#) Low, sending the instruction code, and then driving Chip Select (CS#) High.

The instruction sequence is shown in Figure 10.1 while using the Enable Quad Peripheral Interface mode (EQPI) (38h) command.

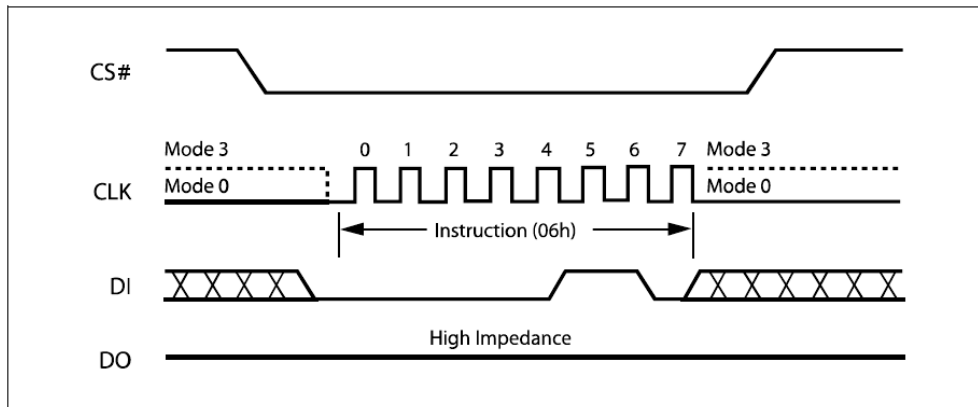

**Figure 8. Write Enable Instruction Sequence Diagram**

**Volatile Status Register Write Enable (50h)**

This feature enable user to change memory protection schemes quickly without waiting for the typical non-volatile bit write cycles or affecting the endurance of the Status Register non-volatile bits. The Volatile Status Register Write Enable (50h) command won't set the Write Enable Latch (WEL) bit, it is only valid for 'Write Status Register' (01h) command to change the Volatile Status Register bit values.

To write to Volatile Status Register, issue the Volatile Status Register Write Enable (50h) command prior issuing WRSR (01h). The Status Register bits will be refresh to Volatile Status Register (SR[7:2]) within tSHSL2 (50ns). Upon power off or the execution of a Software/Hardware Reset, the volatile Status Register bit values will be lost, and the non-volatile Status Register bit values will be restored. The instruction sequence is shown in Figure 9.

The instruction sequence is shown in Figure 10.1 while using the Enable Quad Peripheral Interface mode (EQPI) (38h) command.

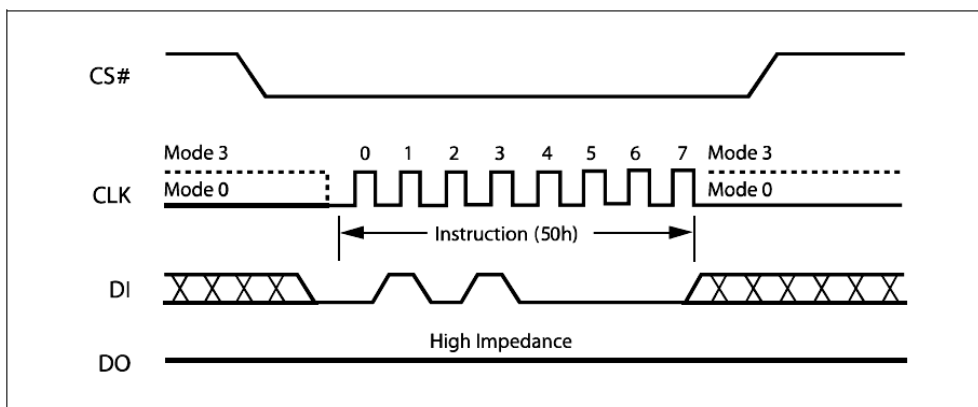
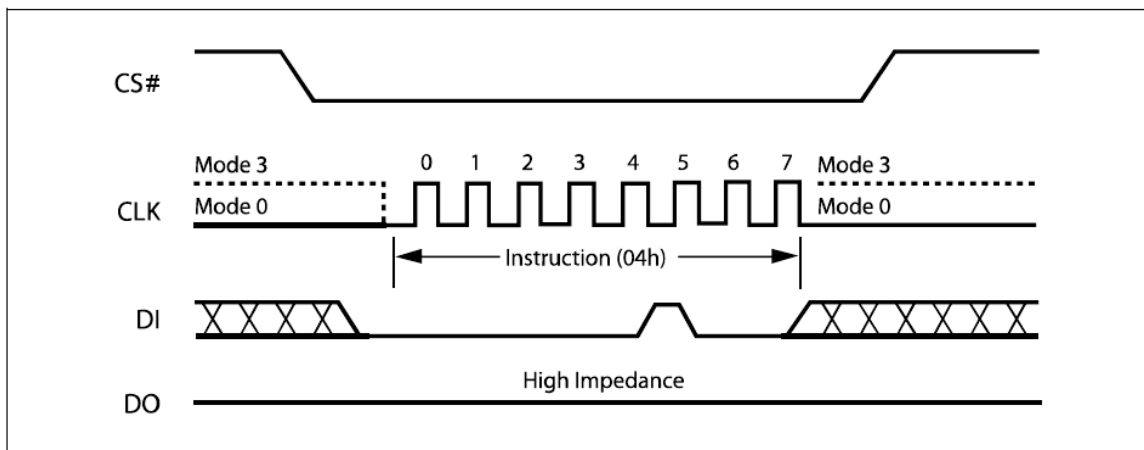

**Figure 9. Volatile Status Register Write Enable Instruction Sequence Diagram**

**Write Disable (WRDI) (04h)**

The Write Disable instruction (Figure 10) resets the Write Enable Latch (WEL) bit in the Status Register to a 0 or exit from OTP mode to normal mode. The Write Disable instruction is entered by driving Chip Select (CS#) low, shifting the instruction code "04h" into the DI pin and then driving Chip Select (CS#) high. Note that the WEL bit is automatically reset after Power-up and upon completion of the Write Status Register, Page Program, Sector Erase, Half Block Erase (HBE), Block Erase (BE) and Chip Erase instructions.

The instruction sequence is shown in Figure 10.1 while using the Enable Quad Peripheral Interface mode (EQPI) (38h) command.



**Figure 10. Write Disable Instruction Sequence Diagram**

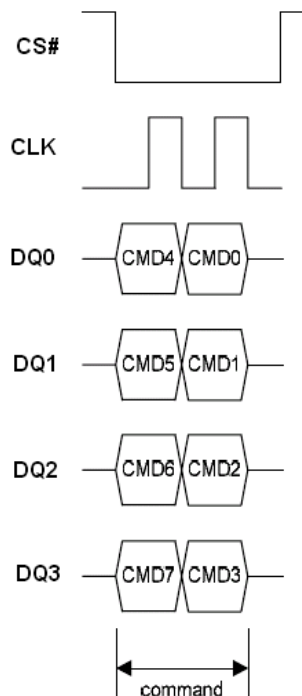

**Figure 10.1 Write Enable/Disable Instruction Sequence in QPI Mode**



**Read Status Register (RDSR) (05h)**

The Read Status Register (RDSR) instruction allows the Status Register to be read. The Status Register may be read at any time, even while a Program, Erase or Write Status Register cycle is in progress. When one of these cycles is in progress, it is recommended to check the Write In Progress (WIP) bit before sending a new instruction to the device. It is also possible to read the Status Register continuously, as shown in Figure 11.

The instruction sequence is shown in Figure 11.1 while using the Enable Quad Peripheral Interface mode (EQPI) (38h) command.

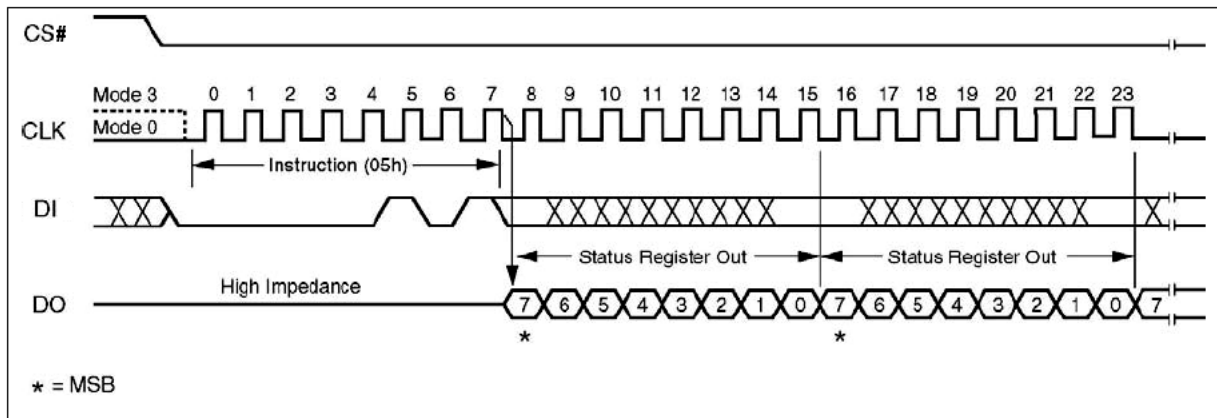

**Figure 11. Read Status Register Instruction Sequence Diagram**

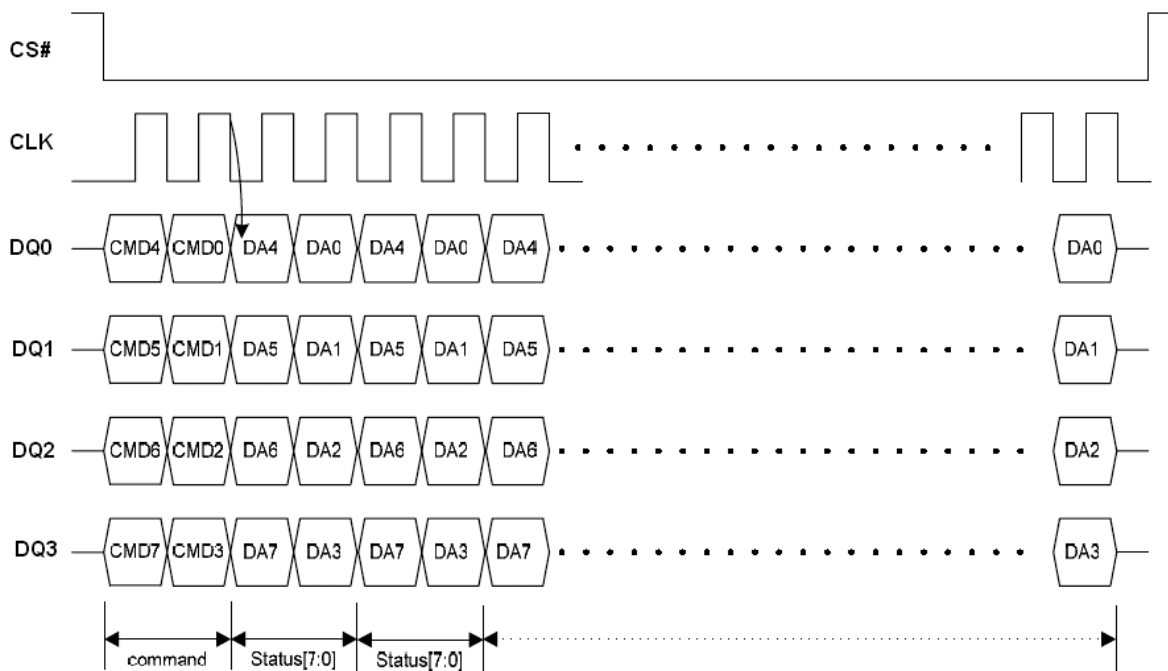

**Figure 11.1 Read Status Register Instruction Sequence in QPI Mode**



Table 7. Status Register Bit Locations

SR7	SR6	SR5	SR4	SR3	SR2	SR1	SR0
PPB bit	EBL bit (Enable boot lock)	BP3 bit	BP2 bit	BP1 bit	BP0 bit	WEL bit	WIP bit
SPL0 bit	Reversed	Reversed	64KB - Block/Sector switch bit	TB bit (Top / Bottom Protect)	SPL1 bit	SPL2 bit	WIP bit

Table 7. 1 Status Register Bit Locations (In Normal mode)

SR7	SR6	SR5	SR4	SR3	SR2	SR1	SR0
PPB Permanent Protection Bit	EBL bit (Enable boot lock)	BP3 bit (Block Protect)	BP2 bit (Block Protect)	BP1 bit (Block Protect)	BP0 bit (Block Protect)	WEL bit (Write Enable Latch)	WIP bit (Write In Progress bit)
1 = BP area and OTP page status are Permanent protected	1 = Lock selected 64KB- Block/Sector	(note 2)	(note 2)	(note 2)	(note 2)	1 = write enable 0 = not write enable	1 = write operation 0 = not in write operation
Non-volatile bit	Non-volatile bit / Volatile bit	Non-volatile bit / Volatile bit	Non-volatile bit / Volatile bit	Non-volatile bit / Volatile bit	Non-volatile bit / Volatile bit	indicator bit	indicator bit

Table 7.2 Status Register Bit Locations (In OTP mode)

SR7	SR6	SR5	SR4	SR3	SR2	SR1	SR0
SPL0 bit	Reversed	Reversed	64KB- Block/Sector switch bit	TB bit (Top/Bottom Protect)	SPL1 bit	SPL2 bit	WIP bit (Write In Progress bit)
1 = security sector 0 is protected			1 = Sector 0 = 64KB-Block (default 0)	1 = Bottom 0 = Top (default 0)	1 = security sector 1 is protected	1 = security sector 2 is protected	1 = write operation 0 = not in write operation
OTP bit / Volatile bit			OTP bit / Volatile bit	OTP bit / Volatile bit	OTP bit / Volatile bit	OTP bit / Volatile bit	indicator bit

**Note**

1. In OTP mode, SR7, SR4, SR3, SR2, SR1 and SR0 are served as SPL0 Bit, 4KB BL bit, TB bit, SPL1 bit SPL2 bit and WIP bit.
2. See the table 3 “Protected Area Sizes Sector Organization”.
3. The OTP sectors cannot be locked anymore if PPB is set to “1” when SPL0 or SPL1 or SPL2 bit is “0”
4. When executed the (RDSR) (05h) command, the WIP (SR0) value is the same as WIP (SR2.0) in table 8.



The status and control bits of the Status Register are as follows:

**WIP bit.** The Write In Progress (WIP) bit indicates whether the memory is busy with a Write Status Register, Program or Erase cycle. When set to 1, such a cycle is in progress, when reset to 0 no such cycle is in progress.

**WEL bit.** The Write Enable Latch (WEL) bit indicates the status of the internal Write Enable Latch. When set to 1 the internal Write Enable Latch is set, when set to 0 the internal Write Enable Latch is reset and no Write Status Register, Program or Erase instruction is accepted.

**BP3, BP2, BP1, BP0 bits.** The Block Protect (BP3, BP2, BP1, BP0) bits are non-volatile. They define the size of the area to be software protected against Program and Erase instructions. These bits are written with the Write Status Register (WRSR) instruction. When one or both of the Block Protect (BP3, BP2, BP1, BP0) bits is set to 1, the relevant memory area (as defined in Table 3.) becomes protected against Page Program (PP), Sector Erase (SE), Half Block Erase(HBE), and Block Erase (BE), instructions. The Block Protect (BP3, BP2, BP1, BP0) bits can be written provided that the Hardware Protected mode has not been set. The Chip Erase (CE) instruction is executed if, and only if, all Block Protect (BP3, BP2, BP1, BP0) bits are 0.

**EBL bit.** The Enable Boot Lock (EBL) bit is used to enable the Boot Lock feature. When this bit is programmed to '1', the sector/block selected by the TB bit and 64KB-Block/Sector switch bit will be locked.

**PPB bit.** The Permanent Protection Bit (PPB) indicates that PPB has been executed successfully. The default of PPB is "0". Once PPB has been programmed with "1" by WRSR command (PPB=1), all the status of Block Protect(BP3, BP2, BP1, BP0) bits and the SPL0, SPL1, SPL2 bits can't be changed again. The Non-volatile bits of the Status Register (PPB, BP3, BP2, BP1, BP0) bits and the SPL0, SPL1, SPL2 bits will be permanent protection.

In OTP mode, SR7, SR4, SR3, SR2, SR1 and SR0 are served as SPL0 Bit, 4KB BL bit, TB bit, SPL1 bit SPL2 bit and WIP bit.

#### **SPL2 bit. (SR1)**

The SPL2 bit is non-volatile One Time Program (OTP) bit in status register that provide the write protect control and status to the security sector 2. User can read/program/erase security sector 2 as normal sector while SPL2 value is equal 0, after SPL2 is programmed with 1 by WRSR command, the security sector 2 is protected from program and erase operation. The SPL2 bit can only be programmed once.

#### **SPL1 bit. (SR2)**

The SPL1 bit is non-volatile One Time Program (OTP) bit in status register that provide the write protect control and status to the security sector 1. User can read/program/erase security sector 1 as normal sector while SPL1 value is equal 0, after SPL1 is programmed with 1 by WRSR command, the security sector 1 is protected from program and erase operation. The SPL1 bit can only be programmed once.

**TB bit. (SR3)**

The Top/Bottom Protect Bit (TB) controls if the Block Protect Bits (BP3, BP2, BP1, BP0) protect from the Top (TB = 0) or the Bottom (TB = 1) of the array as shown in the Status Register Memory Protection table. It also controls if the Top (TB=0) or the Bottom (TB=1) 64KB-block/sector is protected when Boot Lock feature is enabled. The factory default setting is TB = 0. The TB bit can be set with the Write Status Register instruction in OTP mode.

**64KB-Block/Sector switch bit. (SR4)**

The 64KB-Block/Sector switch bit is set by WRSR command in OTP mode. It is used to set the protection area size as block (64KB) or sector (4KB).

**Reserved bit.** Status Register bit locations SR5 and SR6 in OTP mode is reserved for future use.

**SPL0 bit. (SR7)**

The SPL0 bit is non-volatile One Time Program (OTP) bit in status register that provide the write protect control and status to the security sector 0. User can read/program/erase security sector 0 as normal sector while SPL0 value is equal 0, after SPL0 is programmed with 1 by WRSR command, the security sector 0 is protected from program and erase operation. The SPL0 bit can only be programmed once.

**Note:**

1. User must clear the protect bits before entering OTP mode and program the OTP code, then execute WRSR command to lock the OTP sector before leaving OTP mode.
2. If the PPB has been set (PPB = 1), when the SPL0, SPL1, or SPL2 bit keeps in "0", the OTP sector0, OTP sector1, or OTP sector2 cannot be locked anymore.

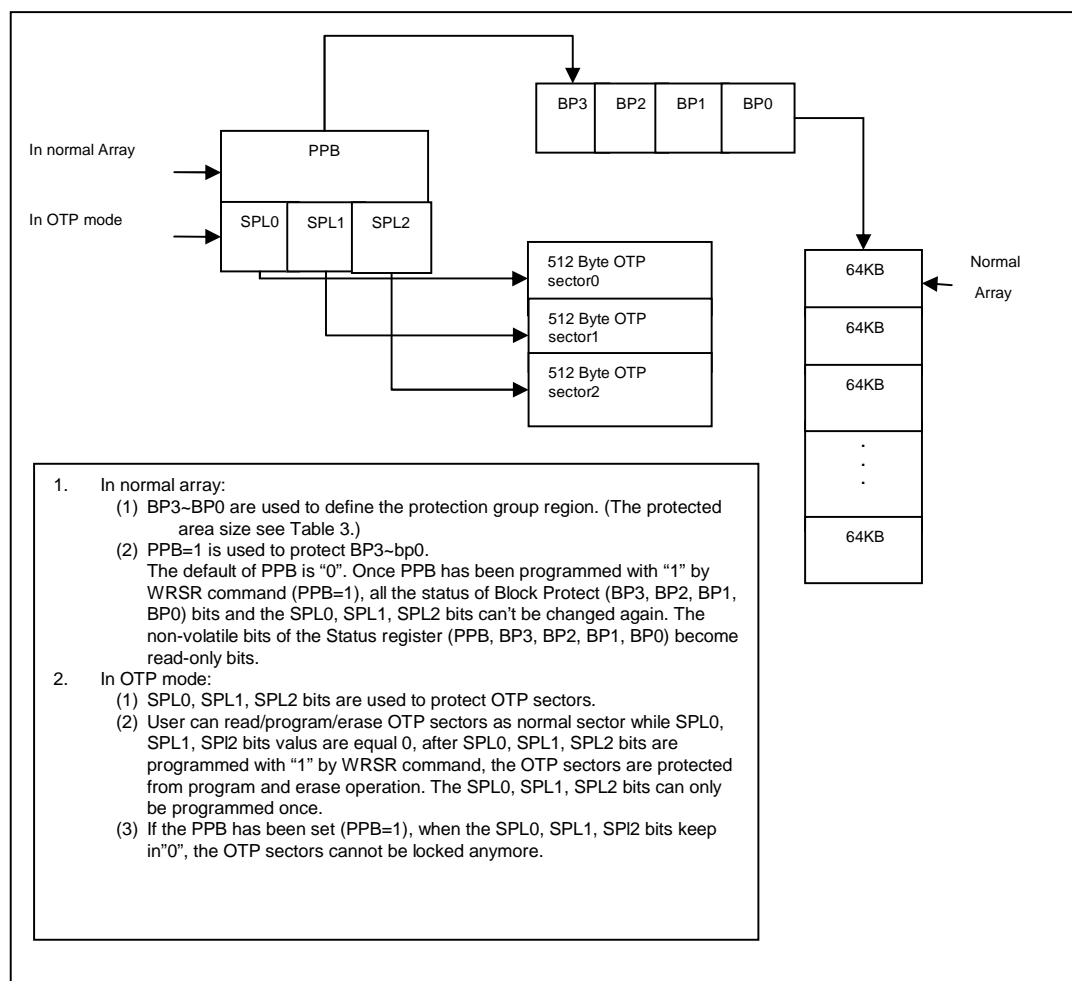

**Write Status Register (WRSR) (01h)**

The Write Status Register (WRSR) instruction allows new values to be written to the Status Register. Before it can be accepted, a Write Enable (WREN) instruction must previously have been executed. After the Write Enable (WREN) instruction has been decoded and executed, the device sets the Write Enable Latch (WEL).

The Write Status Register (WRSR) instruction is entered by driving Chip Select (CS#) Low, followed by the instruction code and the data byte on Serial Data Input (DI).

The instruction sequence is shown in Figure 12. The Write Status Register (WRSR) instruction has no effect on SR1 and SR0 of the Status Register. Chip Select (CS#) must be driven High after the eighth bit of the data byte has been latched in. If not, the Write Status Register (WRSR) instruction is not executed. As soon as Chip Select (CS#) is driven High, the self-timed Write Status Register cycle (whose duration is  $t_{w}$ ) is initiated. While the Write Status Register cycle is in progress, the Status Register may still be read to check the value of the Write In Progress (WIP) bit. The Write In Progress (WIP) bit is 1 during the self-timed Write Status Register cycle, and is 0 when it is completed. When the cycle is completed, the Write Enable Latch (WEL) is reset.

The Write Status Register (WRSR) instruction allows the user to change the values of the Block Protect (BP3, BP2, BP1, BP0) bits, to define the size of the area that is to be treated as read-only, as defined in Table 3. The Write Status Register (WRSR) instruction also allows the user to set the Permanent Protection Bit (PPB). The Permanent Protection Bit (PPB) indicates that PPB has been executed successfully. The default of PPB is "0". Once PPB has been programmed with "1" by WRSR command (PPB=1), all the status of Block Protect (BP3, BP2, BP1, BP0) bits and the SPL0, SPL1, SPL2 bits can't be changed again, and the non-volatile bits of the Status Register (PPB, BP3, BP2, BP1, BP0) become read-only bits.

The instruction sequence is shown in Figure 12.1 while using the Enable Quad Peripheral Interface mode (EQPI) (38h) command.

**NOTE :**

**In the OTP mode without enabling Volatile Status Register function (50h), WRSR command is used to program SPL0 bit, TB bit, 4KB BL bit, SPL1 bit, SPL2 bit switch bit to '1', but these bits can only be programmed once.**

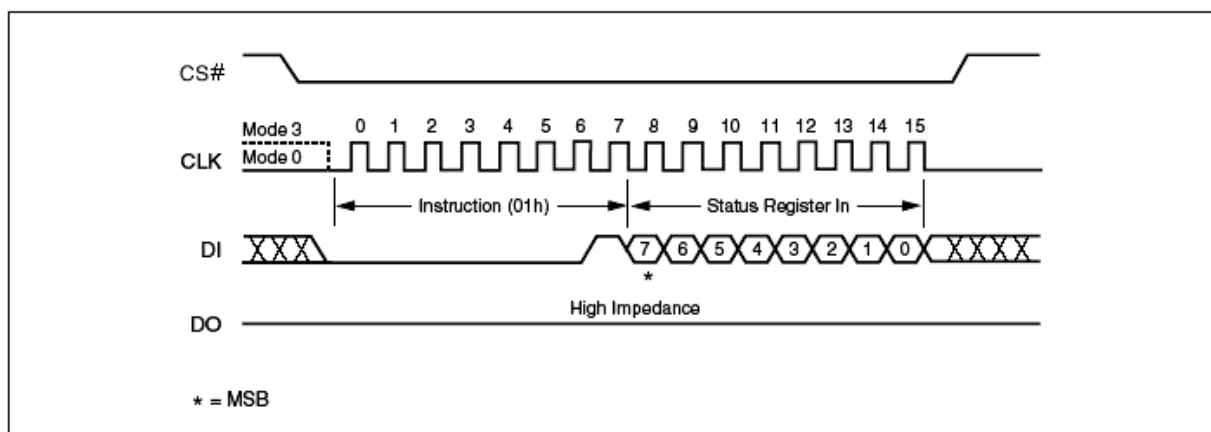

**Figure 12. Write Status Register Instruction Sequence Diagram**



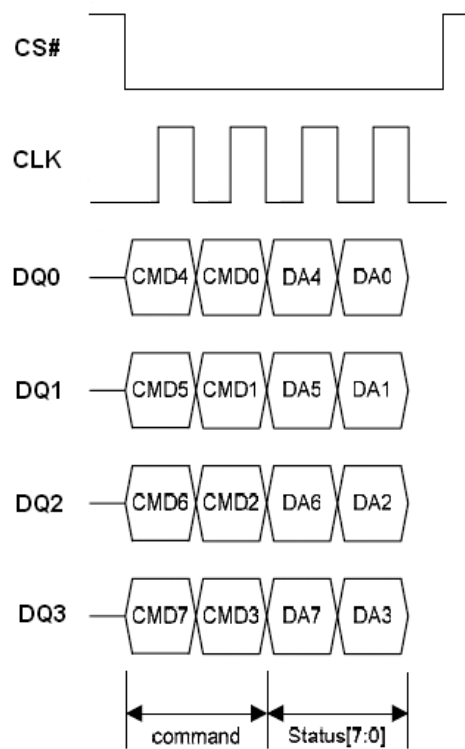

**Figure 12.1 Write Status Register Instruction Sequence in QPI Mode**

**Read Data Bytes (READ) (03h)**

The device is first selected by driving Chip Select (CS#) Low. The instruction code for the Read Data Bytes (READ) instruction is followed by a 3-byte address (A23-A0), each bit being latched-in during the rising edge of Serial Clock (CLK). Then the memory contents, at that address, is shifted out on Serial Data Output (DO), each bit being shifted out, at a maximum frequency  $f_R$ , during the falling edge of Serial Clock (CLK).

The instruction sequence is shown in Figure 13. The first byte addresses can be at any location. The address is automatically incremented to the next higher address after each byte of data is shifted out. The whole memory can, therefore, be read with a single Read Data Bytes (READ) instruction. When the highest address is reached, the address counter rolls over to 000000h, allowing the read sequence to be continued indefinitely.

The Read Data Bytes (READ) instruction is terminated by driving Chip Select (CS#) High. Chip Select (CS#) can be driven High at any time during data output. Any Read Data Bytes (READ) instruction, while an Erase, Program or Write cycle is in progress, is rejected without having any effects on the cycle that is in progress.

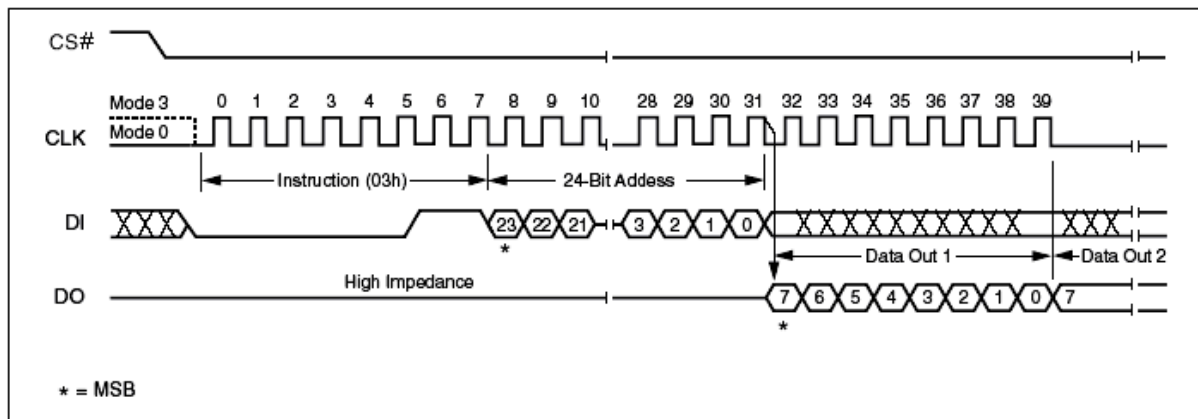

**Figure 13. Read Data Instruction Sequence Diagram**

**Read Data Bytes at Higher Speed (FAST\_READ) (0Bh)**

The device is first selected by driving Chip Select (CS#) Low. The instruction code for the Read Data Bytes at Higher Speed (FAST\_READ) instruction is followed by a 3-byte address (A23-A0) and a dummy byte, each bit being latched-in during the rising edge of Serial Clock (CLK). Then the memory contents, at that address, is shifted out on Serial Data Output (DO), each bit being shifted out, at a maximum frequency  $F_R$ , during the falling edge of Serial Clock (CLK).

The instruction sequence is shown in Figure 14. The first byte addressed can be at any location. The address is automatically incremented to the next higher address after each byte of data is shifted out. The whole memory can, therefore, be read with a single Read Data Bytes at Higher Speed (FAST\_READ) instruction. When the highest address is reached, the address counter rolls over to 000000h, allowing the read sequence to be continued indefinitely.

The Read Data Bytes at Higher Speed (FAST\_READ) instruction is terminated by driving Chip Select (CS#) High. Chip Select (CS#) can be driven High at any time during data output. Any Read Data Bytes at Higher Speed (FAST\_READ) instruction, while an Erase, Program or Write cycle is in progress, is rejected without having any effects on the cycle that is in progress.

The instruction sequence is shown in Figure 14.1 while using the Enable Quad Peripheral Interface mode (EQPI) (38h) command.

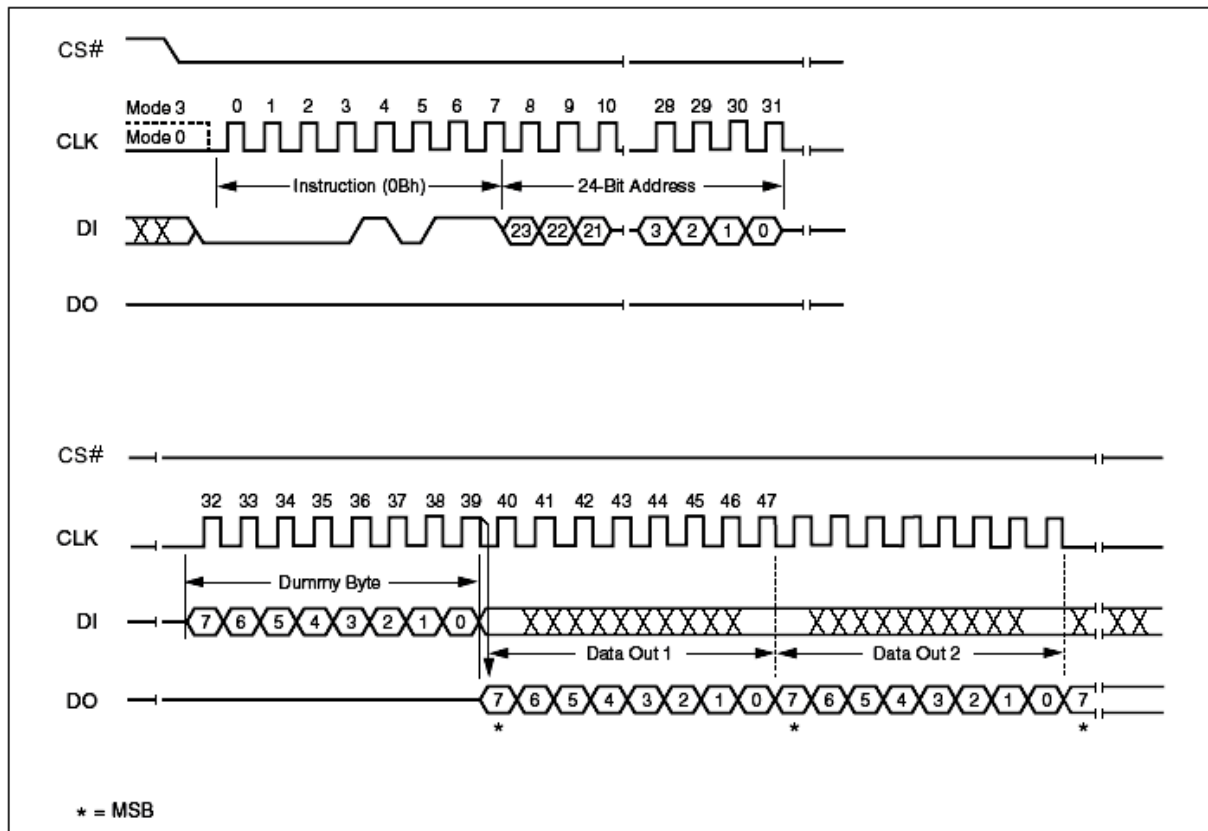

**Figure 14. Fast Read Instruction Sequence Diagram**

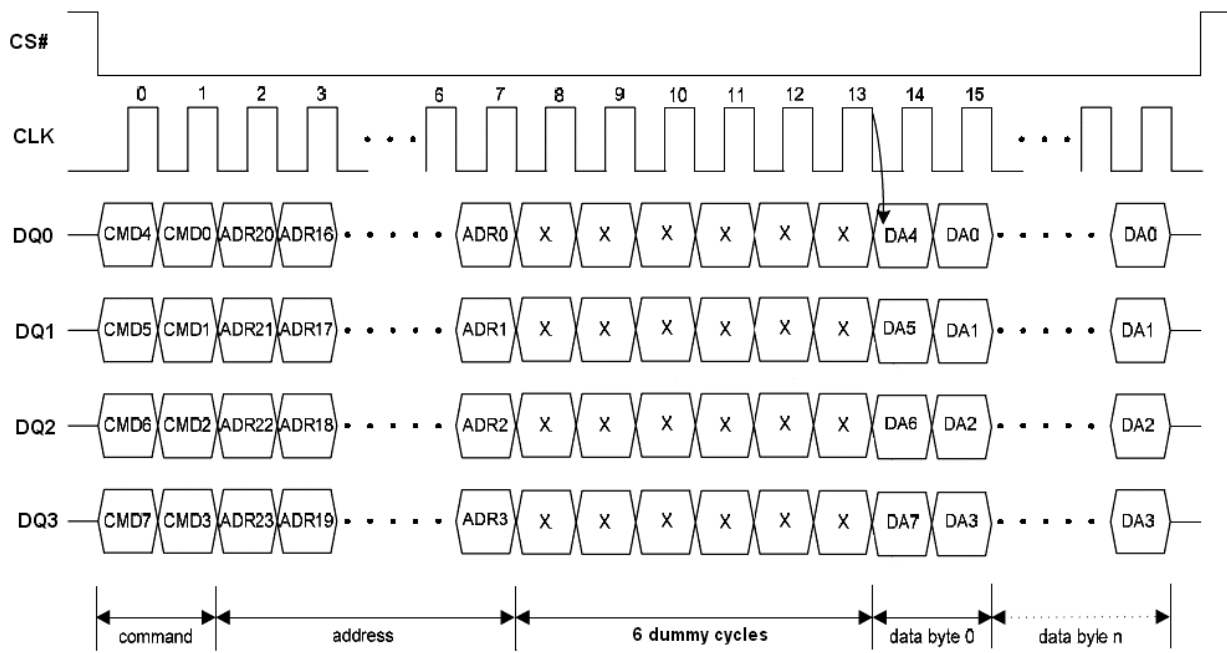
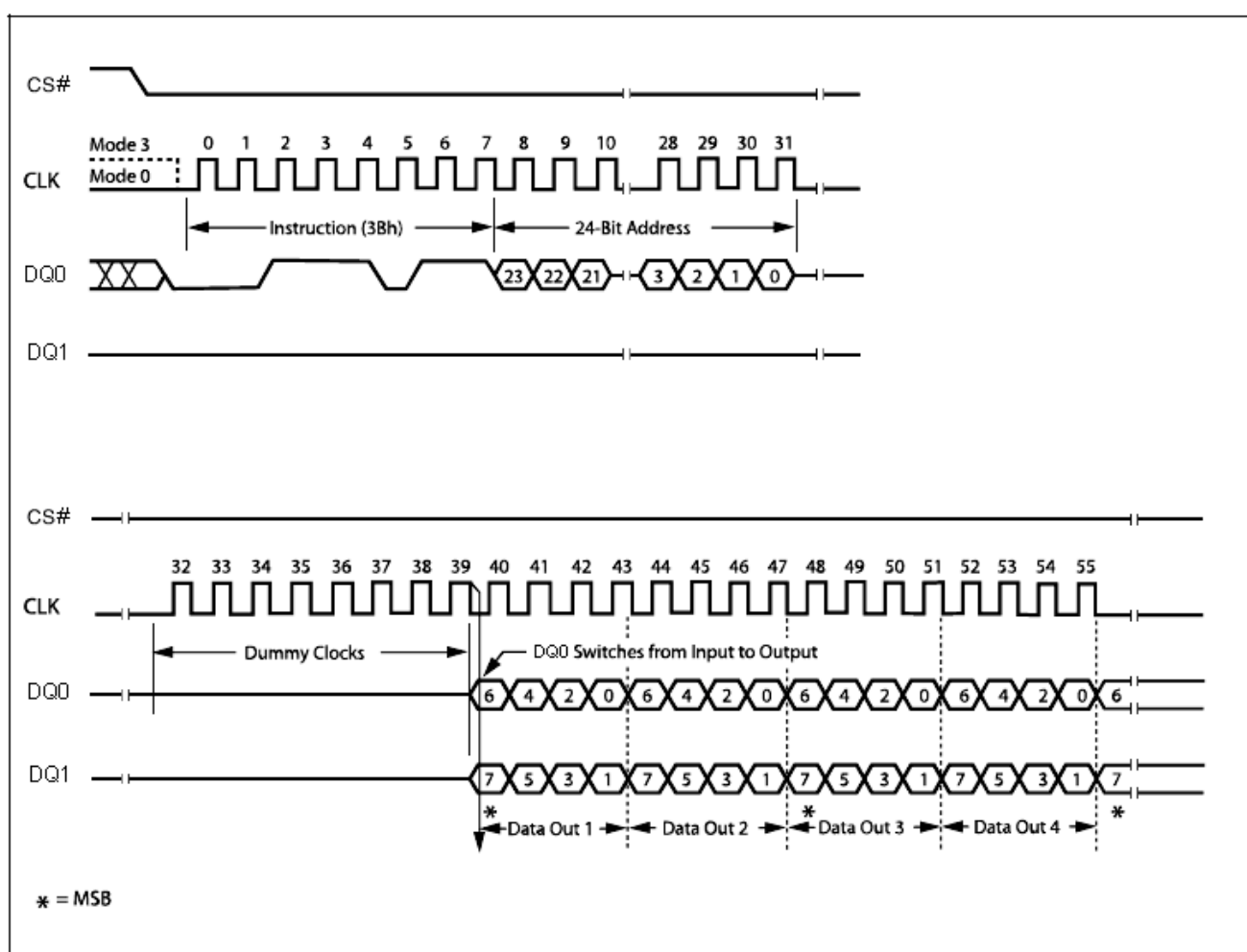

Figure 14.1 Fast Read Instruction Sequence in QPI Mode

**Dual Output Fast Read (3Bh)**

The Dual Output Fast Read (3Bh) is similar to the standard Fast Read (0Bh) instruction except that data is output on two pins, DQ<sub>0</sub> and DQ<sub>1</sub>, instead of just DQ<sub>0</sub>. This allows data to be transferred from the device at twice the rate of standard SPI devices. The Dual Output Fast Read instruction is ideal for quickly downloading code from to RAM upon power-up or for applications that cache code-segments to RAM for execution.

Similar to the Fast Read instruction, the Dual Output Fast Read instruction can operation at the highest possible frequency of FR (see AC Electrical Characteristics). This is accomplished by adding eight “dummy clocks after the 24-bit address as shown in Figure 15. The dummy clocks allow the device’s internal circuits additional time for setting up the initial address. The input data during the dummy clock is “don’t care”. However, the DI pin should be high-impedance prior to the falling edge of the first data out clock.

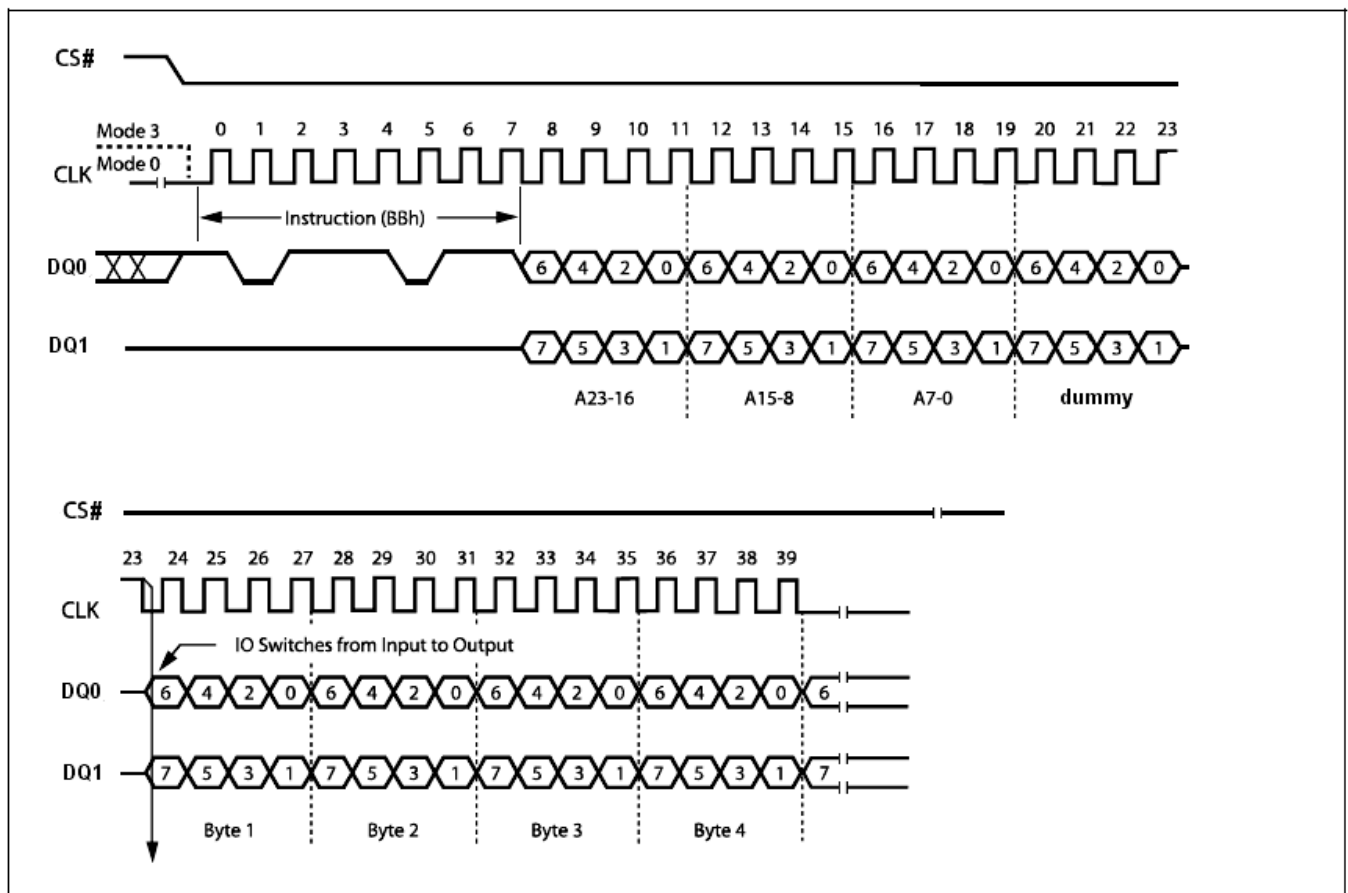

**Figure 15. Dual Output Fast Read Instruction Sequence Diagram**

**Dual Input / Output FAST\_READ (BBh)**

The Dual I/O Fast Read (BBh) instruction allows for improved random access while maintaining two I/O pins, DQ<sub>0</sub> and DQ<sub>1</sub>. It is similar to the Dual Output Fast Read (3Bh) instruction but with the capability to input the Address bits (A23-A0) two bits per clock. This reduced instruction overhead may allow for code execution (XIP) directly from the Dual SPI in some applications.

The Dual I/O Fast Read instruction enable double throughput of Serial Flash in read mode. The address is latched on rising edge of CLK, and data of every two bits (interleave 2 I/O pins) shift out on the falling edge of CLK at a maximum frequency. The first address can be at any location. The address is automatically increased to the next higher address after each byte data is shifted out, so the whole memory can be read out at a single Dual I/O Fast Read instruction. The address counter rolls over to 0 when the highest address has been reached. Once writing Dual I/O Fast Read instruction, the following address/dummy/data out will perform as 2-bit instead of previous 1-bit, as shown in Figure 16.



**Figure 16. Dual Input / Output Fast Read Instruction Sequence Diagram**

**Quad Output Fast Read (6Bh)**

The Quad Output Fast Read (6Bh) instruction is similar to the Dual Output Fast Read (3Bh) instruction except that data is output through four pins, DQ0, DQ1, DQ2 and DQ3 and eight dummy clocks are required prior to the data output. The Quad Output dramatically reduces instruction overhead allowing faster random access for code execution (XIP) directly from the Quad SPI.

The Quad Output Fast Read (6Bh) address is latching on rising edge of CLK, and data of every four bits (interleave on 4 I/O pins) shift out on the falling edge of CLK at a maximum frequency FR. The first address can be any location. The address is automatically increased to the next higher address after each byte data is shifted out, so the whole memory can be read out at a single Quad Output Fast Read instruction. The address counter rolls over to 0 when the highest address has been reached.

The sequence of issuing Quad Output Fast Read (6Bh) instruction is: CS# goes low -> sending Quad Output Fast Read (6Bh) instruction -> 24-bit address on DQ0 -> 8 dummy clocks -> data out interleave on DQ3, DQ2, DQ1 and DQ0 -> to end Quad Output Fast Read (6Bh) operation can use CS# to high at any time during data out, as shown in Figure 17. The WP# (DQ2) and HOLD# (DQ3) need to drive high before address input if WHDIS bit in Status Register is 0.

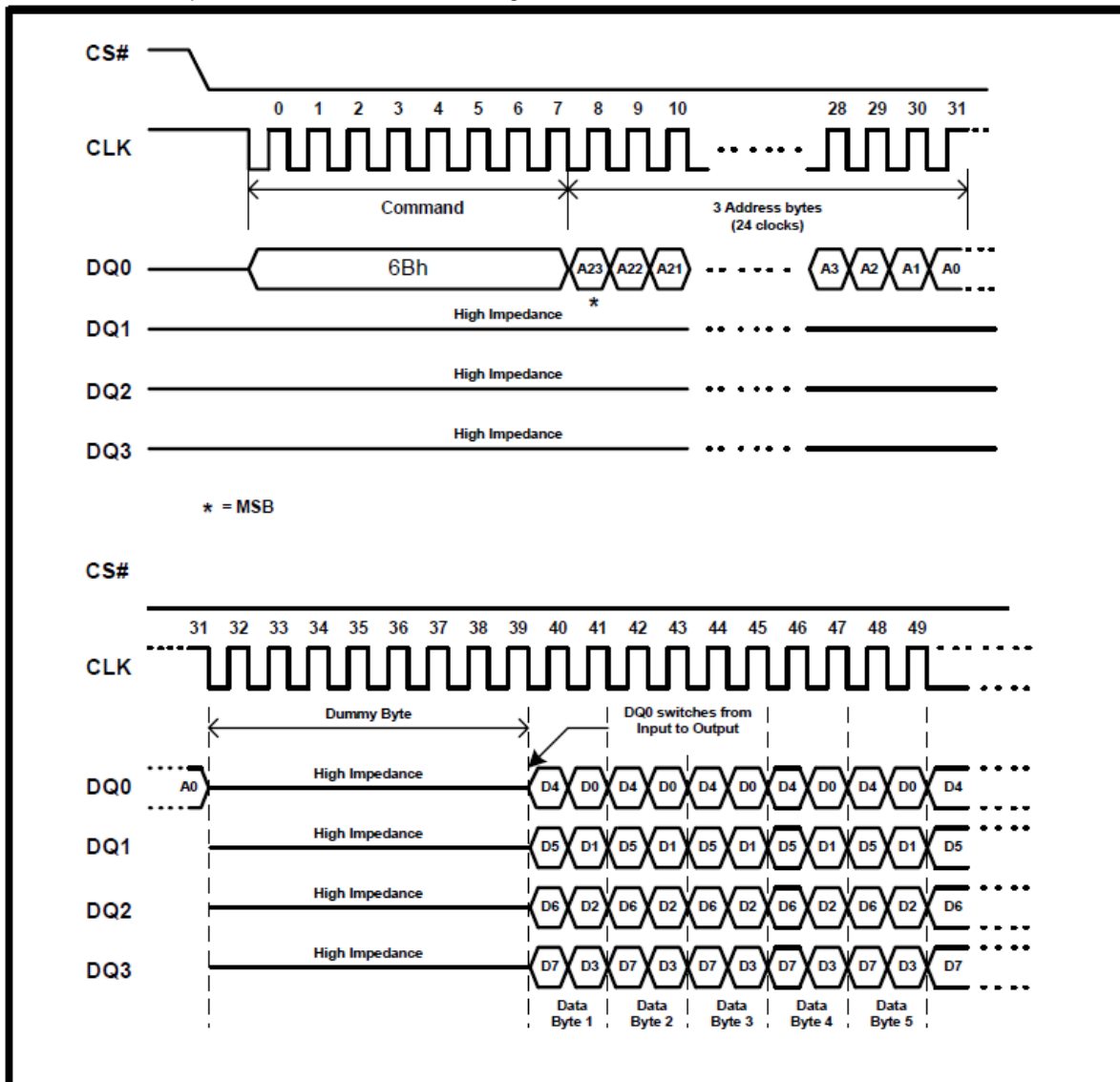

**Figure 17. Quad Output Fast Read Instruction Sequence Diagram**

**Quad Input / Output FAST\_READ (EBh)**

The Quad Input/Output FAST\_READ (EBh) instruction is similar to the Dual I/O Fast Read (BBh) instruction except that address and data bits are input and output through four pins, DQ<sub>0</sub>, DQ<sub>1</sub>, DQ<sub>2</sub> and DQ<sub>3</sub> and six dummy clocks are required prior to the data output. The Quad I/O dramatically reduces instruction overhead allowing faster random access for code execution (XIP) directly from the Quad SPI.

The Quad Input/Output FAST\_READ (EBh) instruction enable quad throughput of Serial Flash in read mode. The address is latching on rising edge of CLK, and data of every four bits (interleave on 4 I/O pins) shift out on the falling edge of CLK at a maximum frequency F<sub>R</sub>. The first address can be any location. The address is automatically increased to the next higher address after each byte data is shifted out, so the whole memory can be read out at a single Quad Input/Output FAST\_READ instruction. The address counter rolls over to 0 when the highest address has been reached. Once writing Quad Input/Output FAST\_READ instruction, the following address/dummy/data out will perform as 4-bit instead of previous 1-bit.

The sequence of issuing Quad Input/Output FAST\_READ (EBh) instruction is: CS# goes low -> sending Quad Input/Output FAST\_READ (EBh) instruction -> 24-bit address interleave on DQ<sub>3</sub>, DQ<sub>2</sub>, DQ<sub>1</sub> and DQ<sub>0</sub> -> 6 dummy cycles -> data out interleave on DQ<sub>3</sub>, DQ<sub>2</sub>, DQ<sub>1</sub> and DQ<sub>0</sub> -> to end Quad Input/Output FAST\_READ (EBh) operation can use CS# to high at any time during data out, as shown in Figure 18.

The instruction sequence is shown in Figure 18,1 while using the Enable Quad Peripheral Interface mode (EQPI) (38h) command.

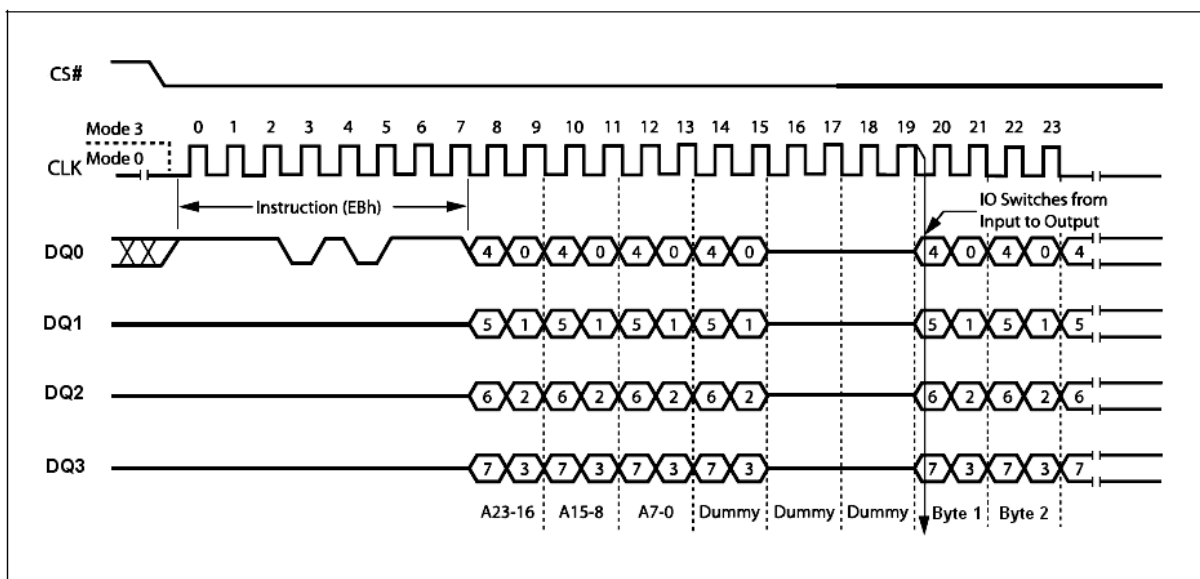

**Figure 18. Quad Input / Output Fast Read Instruction Sequence Diagram**



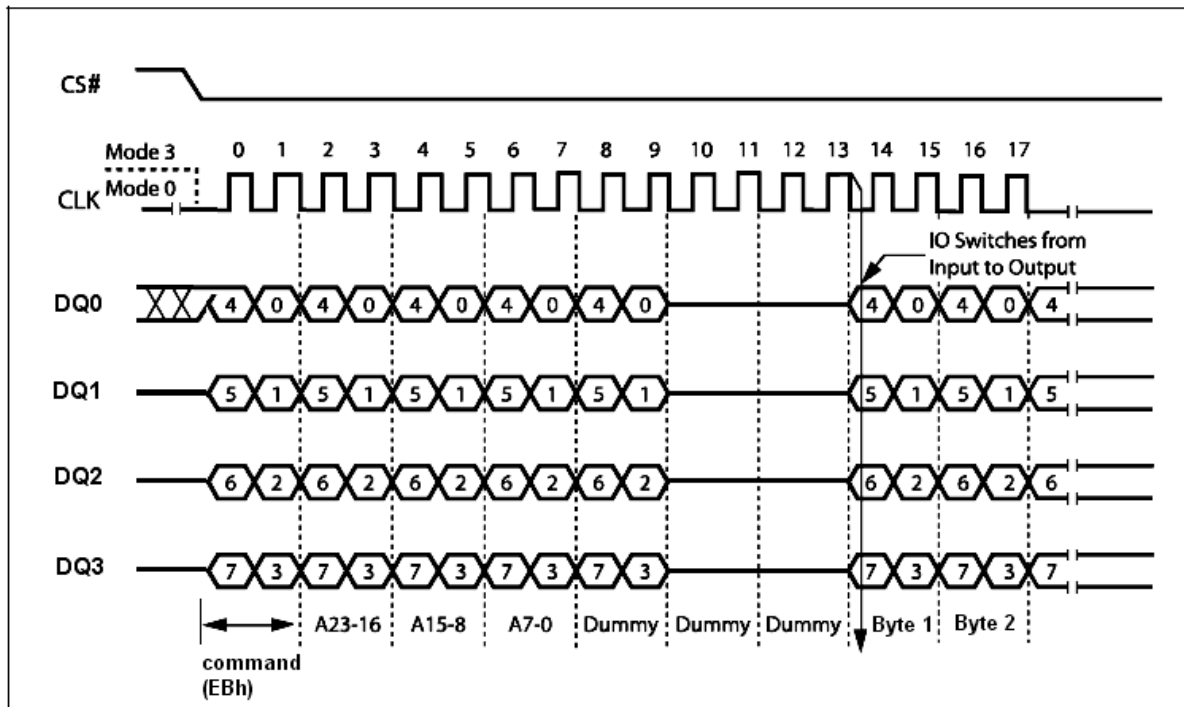

**Figure 18.1 Quad Input / Output Fast Read Instruction Sequence in QPI Mode**

Another sequence of issuing Quad Input/Output FAST\_READ (EBh) instruction especially useful in random access is : CS# goes low -> sending Quad Input/Output FAST\_READ (EBh) instruction -> 24-bit address interleave on DQ<sub>3</sub>, DQ<sub>2</sub>, DQ<sub>1</sub> and DQ<sub>0</sub> -> performance enhance toggling bit P[7:0] -> 4 dummy cycles -> data out interleave on DQ<sub>3</sub>, DQ<sub>2</sub>, DQ<sub>1</sub> and DQ<sub>0</sub> till CS# goes high -> CS# goes low (reduce Quad Input/Output FAST\_READ (EBh) instruction) -> 24-bit access address, as shown in Figure 18.

In the performance – enhancing mode, P[7:4] must be toggling with P[3:0] ; likewise P[7:0] = A5h, 5Ah, F0h or 0Fh can make this mode continue and reduce the next Quad Input/Output FAST\_READ (EBh) instruction. Once P[7:4] is no longer toggling with P[3:0] ; likewise P[7:0] = FFh, 00h, AAh or 55h. And afterwards CS# is raised, the system then will escape from performance enhance mode and return to normal operation.

While Program/ Erase/ Write Status Register is in progress, Quad Input/Output FAST\_READ (EBh) instruction is rejected without impact on the Program/ Erase/ Write Status Register current cycle.

The instruction sequence is shown in Figure 19.1 while using the Enable Quad Peripheral Interface mode (EQPI) (38h) command.

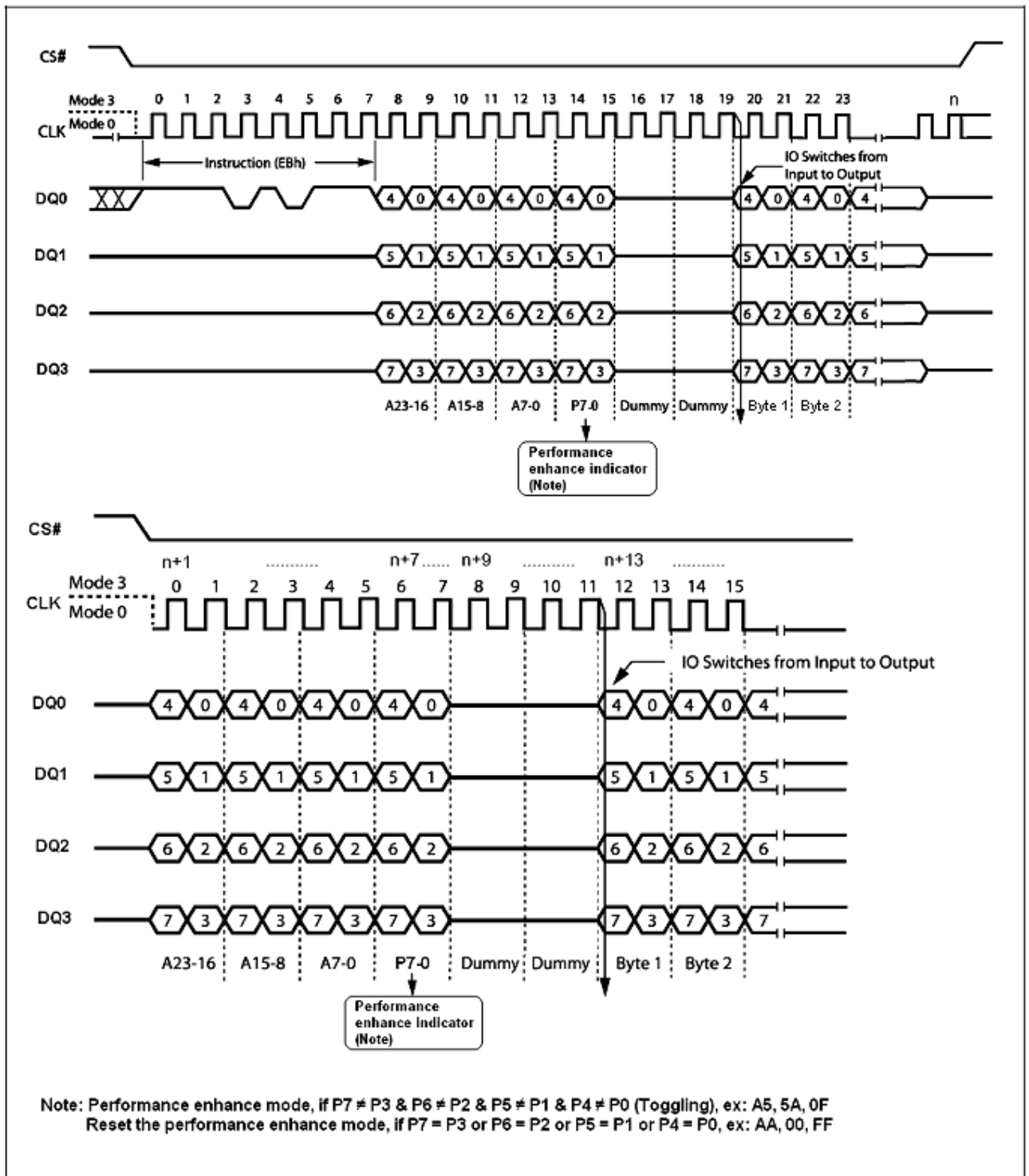
**Figure 19. Quad Input/Output Fast Read Enhance Performance Mode Sequence Diagram**

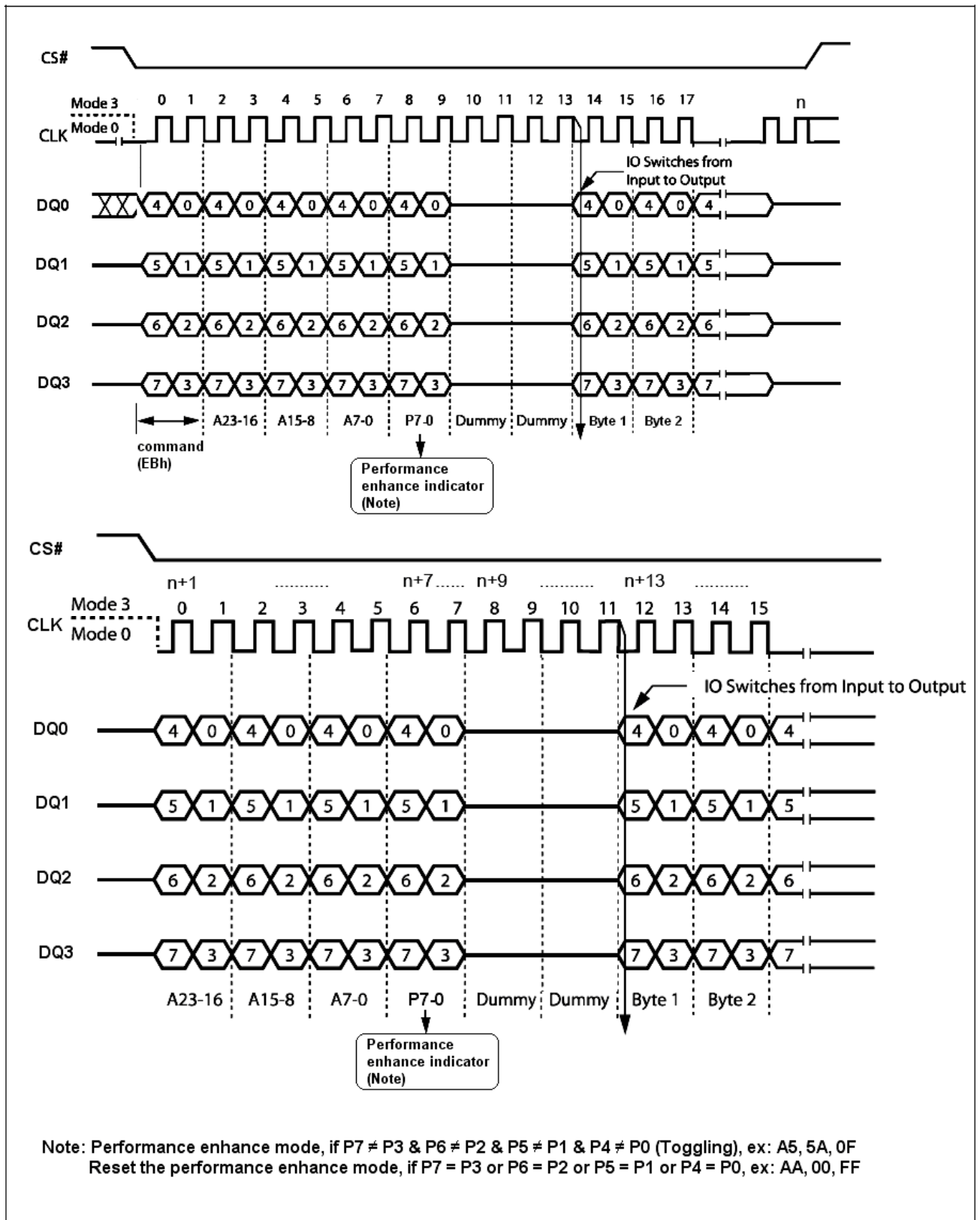
**Figure 19.1 Quad Input/Output Fast Read Enhance Performance Mode Sequence in QPI Mode**

**Page Program (PP) (02h)**

The Page Program (PP) instruction allows bytes to be programmed in the memory. Before it can be accepted, a Write Enable (WREN) instruction must previously have been executed. After the Write Enable (WREN) instruction has been decoded, the device sets the Write Enable Latch (WEL).

The Page Program (PP) instruction is entered by driving Chip Select (CS#) Low, followed by the instruction code, three address bytes and at least one data byte on Serial Data Input (DI). If the 8 least significant address bits (A7-A0) are not all zero, all transmitted data that goes beyond the end of the current page are programmed from the start address of the same page (from the address whose 8 least significant bits (A7-A0) are all zero). Chip Select (CS#) must be driven Low for the entire duration of the sequence.

The instruction sequence is shown in Figure 20. If more than 256 bytes are sent to the device, previously latched data are discarded and the last 256 data bytes are guaranteed to be programmed correctly within the same page. If less than 256 Data bytes are sent to device, they are correctly programmed at the requested addresses without having any effects on the other bytes of the same page.

Chip Select (CS#) must be driven High after the eighth bit of the last data byte has been latched in, otherwise the Page Program (PP) instruction is not executed.

As soon as Chip Select (CS#) is driven High, the self-timed Page Program cycle (whose duration is  $t_{pp}$ ) is initiated. While the Page Program cycle is in progress, the Status Register may be read to check the value of the Write In Progress (WIP) bit. The Write In Progress (WIP) bit is 1 during the self-timed Page Program cycle, and is 0 when it is completed. At some unspecified time before the cycle is completed, the Write Enable Latch (WEL) bit is reset.

A Page Program (PP) instruction applied to a page which is protected by the Block Protect (BP3, BP2, BP1, BP0) bits (see Table 3) is not executed.

The instruction sequence is shown in Figure 20.1 while using the Enable Quad Peripheral Interface mode (EQPI) (38h) command.

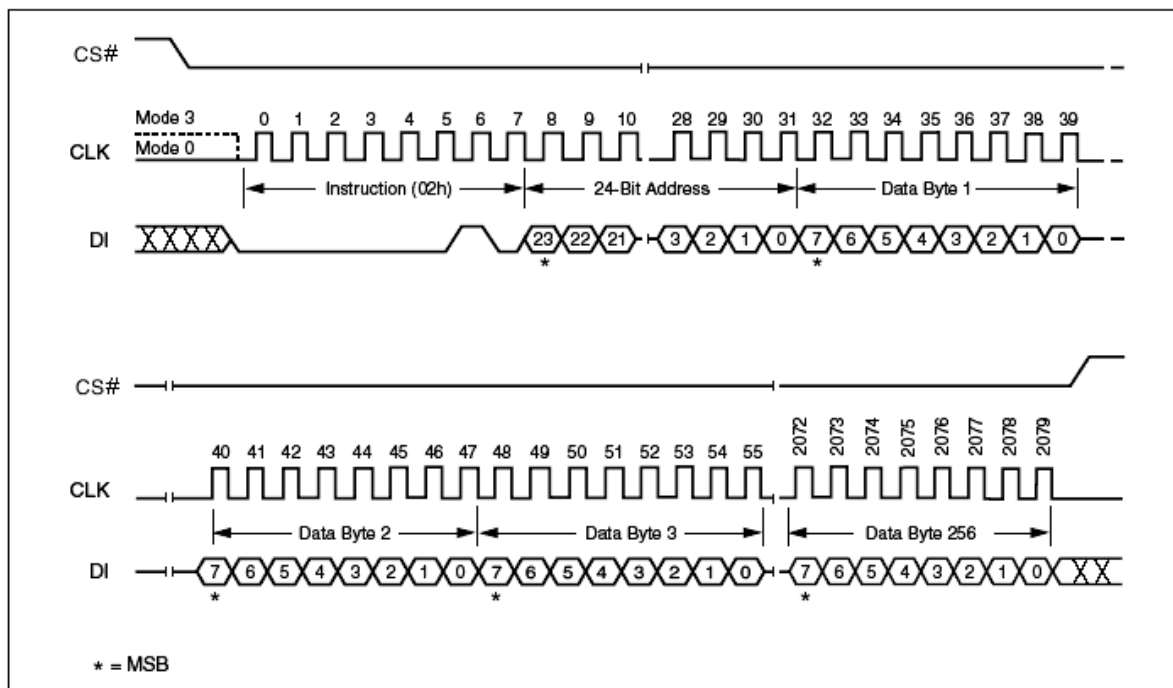

**Figure 20. Page Program Instruction Sequence Diagram**

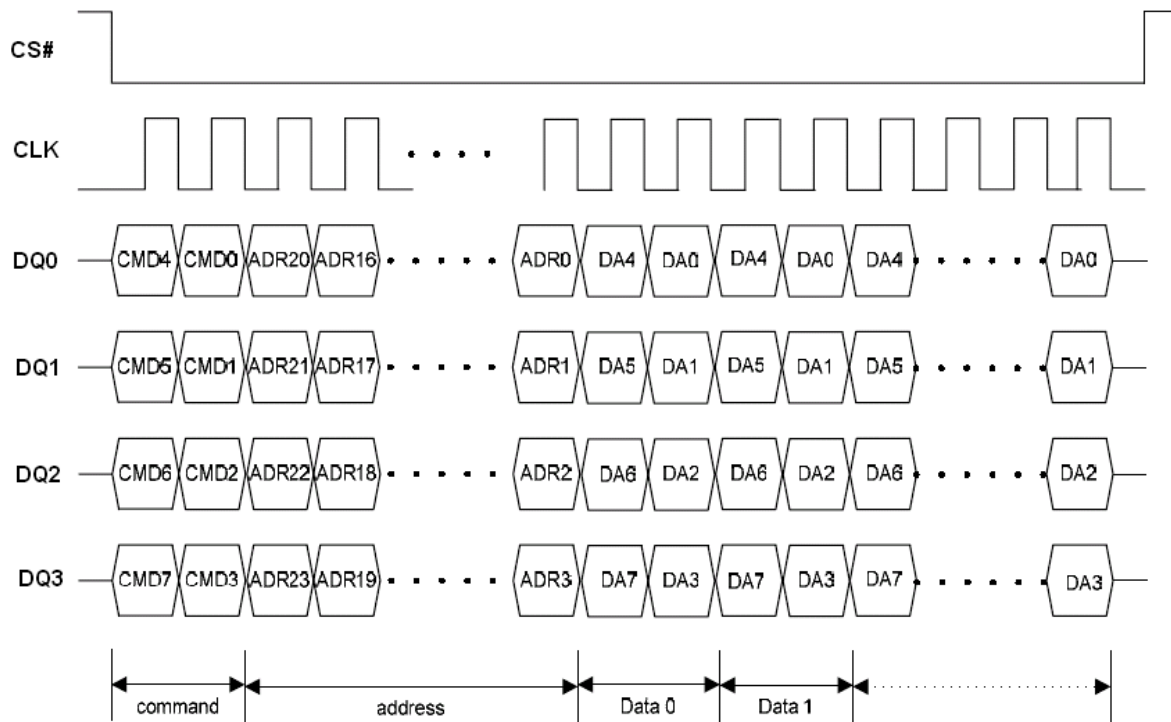
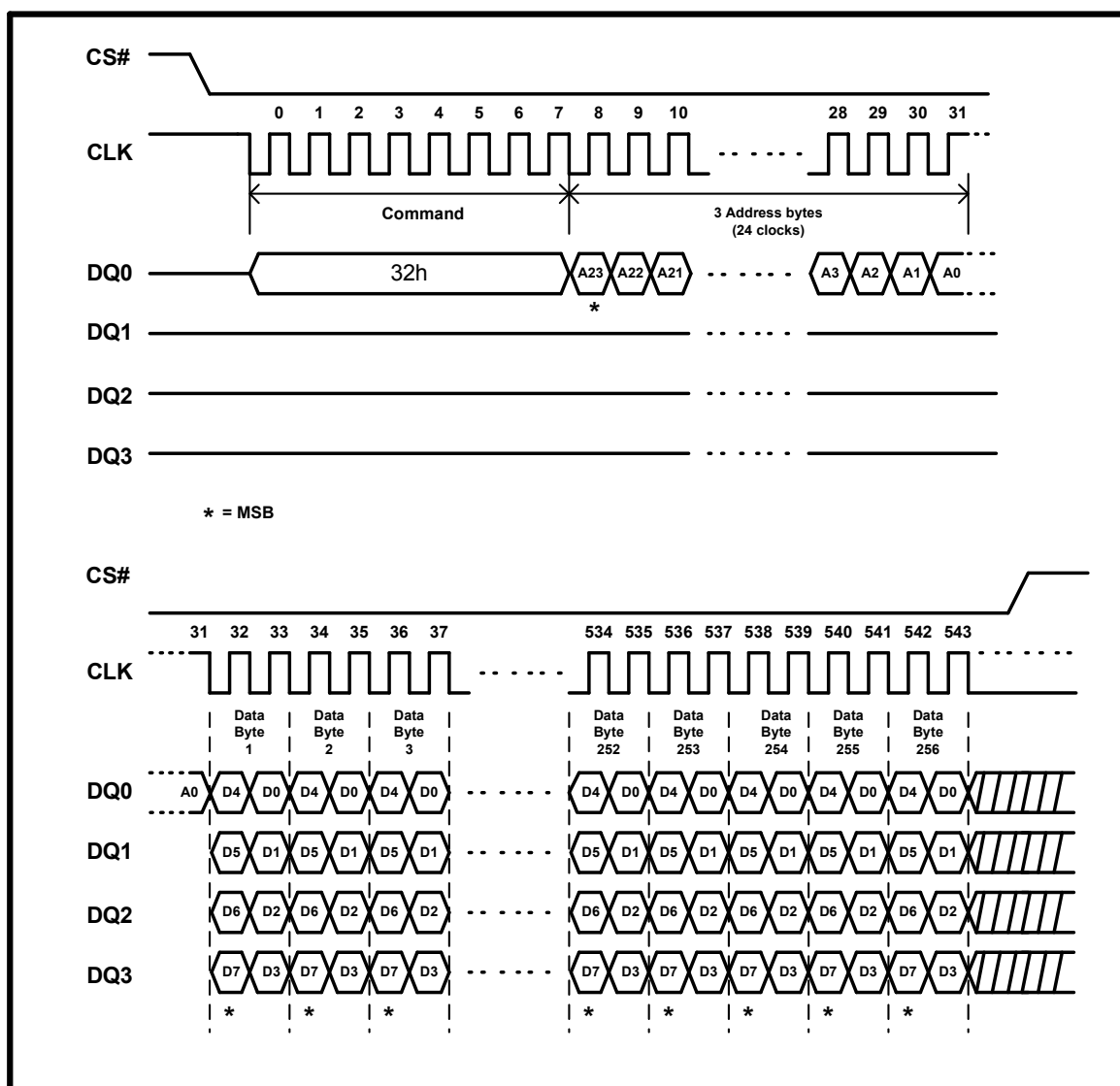

**Figure 20.1 Program Instruction Sequence in QPI Mode**

**Quad Input Page Program (QPP) (32h)**

The Quad Page Program (QPP) instruction allows up to 256 bytes of data to be programmed at previously erased (FFh) memory locations using four pins: DQ<sub>0</sub>, DQ<sub>1</sub>, DQ<sub>2</sub> and DQ<sub>3</sub>. The Quad Page Program can improve performance for PROM Programmer and applications that have slow clock speeds < 5MHz. Systems with faster clock speed will not realize much benefit for the Quad Page Program instruction since the inherent page program time is much greater than the time it take to clock-in the data.

A Write Enable instruction must be executed before the device will accept the Quad Page Program (QPP) instruction (SR1, WEL=1). The instruction is initiated by driving the CS# pin low then shifting the instruction code "32h" followed by a 24-bit address (A23-A0) and at least one data byte, into the IO pins. The CS# pin must be held low for the entire length of the instruction while data is being sent to the device. All other functions of Quad Page Program (QPP) are identical to standard Page Program. The Quad Page Program (QPP) instruction sequence is shown in Figure 21.



**Figure 21. Quad Input Page Program Instruction Sequence Diagram (SPI Mode only)**

**Sector Erase (SE) (20h)**

The Sector Erase (SE) instruction sets to 1 (FFh) all bits inside the chosen sector. Before it can be accepted, a Write Enable (WREN) instruction must previously have been executed. After the Write Enable (WREN) instruction has been decoded, the device sets the Write Enable Latch (WEL).

The Sector Erase (SE) instruction is entered by driving Chip Select (CS#) Low, followed by the instruction code, and three address bytes on Serial Data Input (DI). Any address inside the Sector (see Table 2) is a valid address for the Sector Erase (SE) instruction. Chip Select (CS#) must be driven Low for the entire duration of the sequence.

The instruction sequence is shown in Figure 22. Chip Select (CS#) must be driven High after the eighth bit of the last address byte has been latched in, otherwise the Sector Erase (SE) instruction is not executed. As soon as Chip Select (CS#) is driven High, the self-timed Sector Erase cycle (whose duration is  $t_{SE}$ ) is initiated. While the Sector Erase cycle is in progress, the Status Register may be read to check the value of the Write In Progress (WIP) bit. The Write In Progress (WIP) bit is 1 during the self-timed Sector Erase cycle, and is 0 when it is completed. At some unspecified time before the cycle is completed, the Write Enable Latch (WEL) bit is reset.

A Sector Erase (SE) instruction applied to a sector which is protected by the Block Protect (BP3, BP2, BP1, BP0) bits (see Table 3) is not executed.

The instruction sequence is shown in Figure 24.1 while using the Enable Quad Peripheral Interface mode (EQPI) (38h) command.

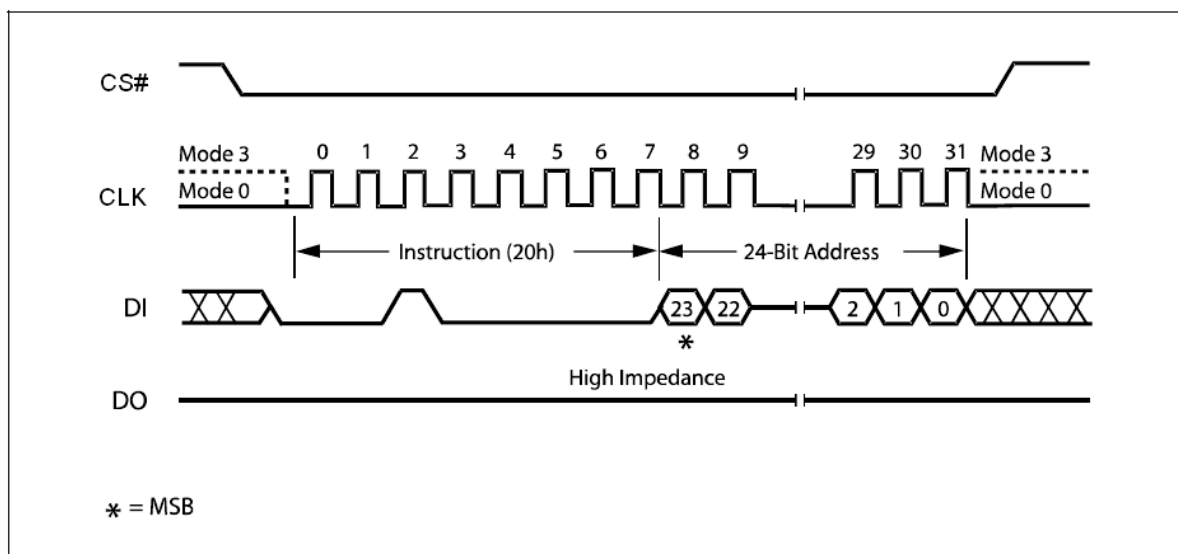

**Figure 22. Sector Erase Instruction Sequence Diagram**

**32KB Half Block Erase (HBE) (52h)**

The Half Block Erase (HBE) instruction sets to 1 (FFh) all bits inside the chosen block. Before it can be accepted, a Write Enable (WREN) instruction must previously have been executed. After the Write Enable (WREN) instruction has been decoded, the device sets the Write Enable Latch (WEL).

The Half Block Erase (HBE) instruction is entered by driving Chip Select (CS#) Low, followed by the instruction code, and three address bytes on Serial Data Input (DI). Any address inside the Block (see Table 2) is a valid address for the Half Block Erase (HBE) instruction. Chip Select (CS#) must be driven Low for the entire duration of the sequence.

The instruction sequence is shown in Figure 23. Chip Select (CS#) must be driven High after the eighth bit of the last address byte has been latched in, otherwise the Half Block Erase (HBE) instruction is not executed. As soon as Chip Select (CS#) is driven High, the self-timed Half Block Erase cycle (whose duration is  $t_{HBE}$ ) is initiated. While the Block Erase cycle is in progress, the Status Register may be read to check the value of the Write In Progress (WIP) bit. The Write In Progress (WIP) bit is 1 during the self-timed Half Block Erase cycle, and is 0 when it is completed. At some unspecified time before the cycle is completed, the Write Enable Latch (WEL) bit is reset.

A Half Block Erase (HBE) instruction applied to a block which is protected by the Block Protect (BP3, BP2, BP1, BP0) bits (see Table 3) is not executed.

The instruction sequence is shown in Figure 24.1 while using the Enable Quad Peripheral Interface mode (EQPI) (38h) command.

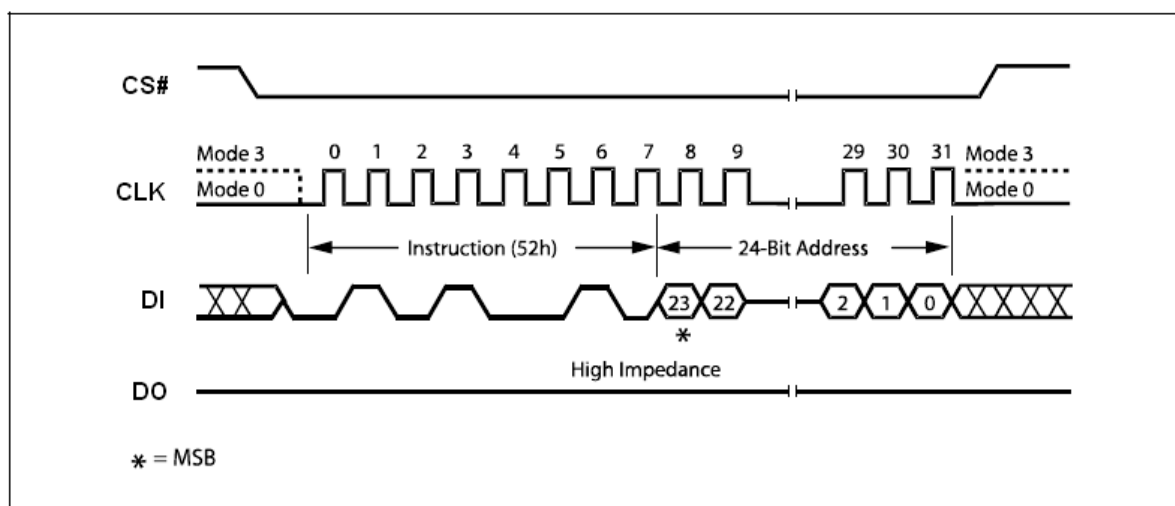

**Figure 23. 32KB Half Block Erase Instruction Sequence Diagram**



**64KB Block Erase (BE) (D8h)**

The Block Erase (BE) instruction sets to 1 (FFh) all bits inside the chosen block. Before it can be accepted, a Write Enable (WREN) instruction must previously have been executed. After the Write Enable (WREN) instruction has been decoded, the device sets the Write Enable Latch (WEL).

The Block Erase (BE) instruction is entered by driving Chip Select (CS#) Low, followed by the instruction code, and three address bytes on Serial Data Input (DI). Any address inside the Block (see Table 2) is a valid address for the Block Erase (BE) instruction. Chip Select (CS#) must be driven Low for the entire duration of the sequence.

The instruction sequence is shown in Figure 24. Chip Select (CS#) must be driven High after the eighth bit of the last address byte has been latched in, otherwise the Block Erase (BE) instruction is not executed. As soon as Chip Select (CS#) is driven High, the self-timed Block Erase cycle (whose duration is  $t_{BE}$ ) is initiated. While the Block Erase cycle is in progress, the Status Register may be read to check the value of the Write In Progress (WIP) bit. The Write In Progress (WIP) bit is 1 during the self-timed Block Erase cycle, and is 0 when it is completed. At some unspecified time before the cycle is completed, the Write Enable Latch (WEL) bit is reset.

A Block Erase (BE) instruction applied to a block which is protected by the Block Protect (BP3, BP2, BP1, BP0) bits (see Table 3) is not executed.

The instruction sequence is shown in Figure 24.1 while using the Enable Quad Peripheral Interface mode (EQPI) (38h) command.

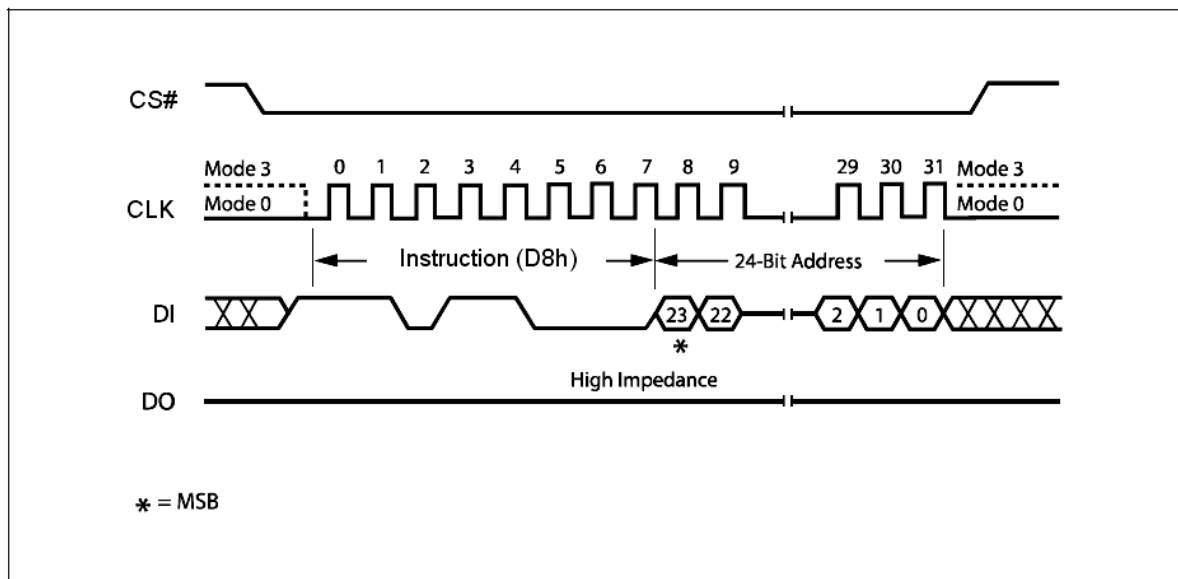

**Figure 24. 64KB Block Erase Instruction Sequence Diagram**

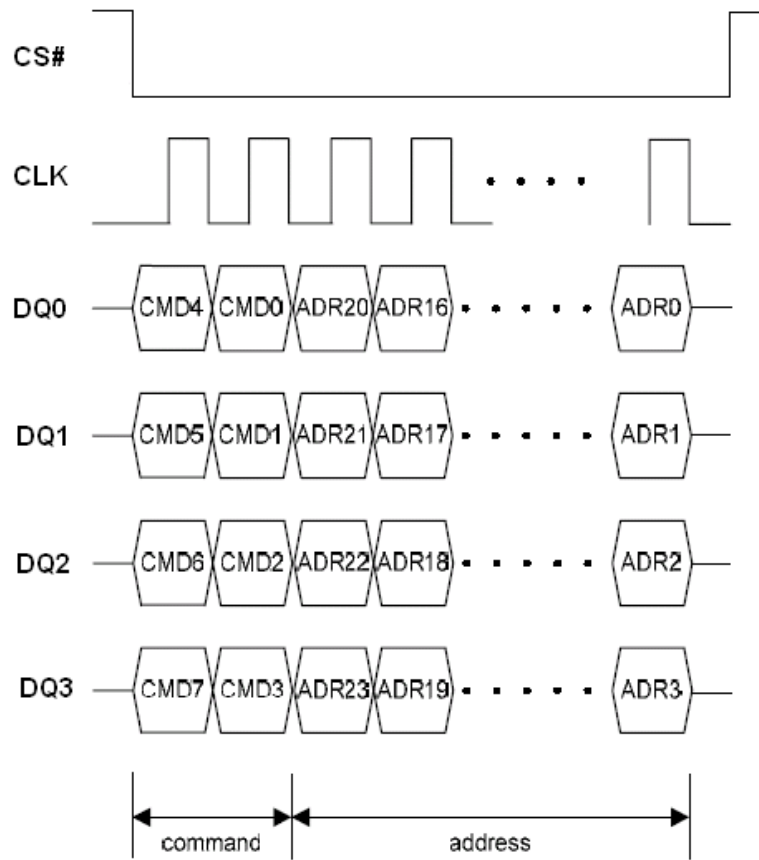

**Figure 24.1 Half Block/Block/Sector Erase Instruction Sequence in QPI Mode**

**Chip Erase (CE) (C7h/60h)**

The Chip Erase (CE) instruction sets all bits to 1 (FFh). Before it can be accepted, a Write Enable (WREN) instruction must previously have been executed. After the Write Enable (WREN) instruction has been decoded, the device sets the Write Enable Latch (WEL).

The Chip Erase (CE) instruction is entered by driving Chip Select (CS#) Low, followed by the instruction code on Serial Data Input (DI). Chip Select (CS#) must be driven Low for the entire duration of the sequence.

The instruction sequence is shown in Figure 25. Chip Select (CS#) must be driven High after the eighth bit of the instruction code has been latched in, otherwise the Chip Erase instruction is not executed. As soon as Chip Select (CS#) is driven High, the self-timed Chip Erase cycle (whose duration is  $t_{CE}$ ) is initiated. While the Chip Erase cycle is in progress, the Status Register may be read to check the value of the Write In Progress (WIP) bit. The Write In Progress (WIP) bit is 1 during the self-timed Chip Erase cycle, and is 0 when it is completed. At some unspecified time before the cycle is completed, the Write Enable Latch (WEL) bit is reset.

The Chip Erase (CE) instruction is executed only if all Block Protect (BP3, BP2, BP1, BP0) bits are 0. The Chip Erase (CE) instruction is ignored if one, or more blocks are protected.

The instruction sequence is shown in Figure 25.1 while using the Enable Quad Peripheral Interface mode (EQPI) (38h) command.

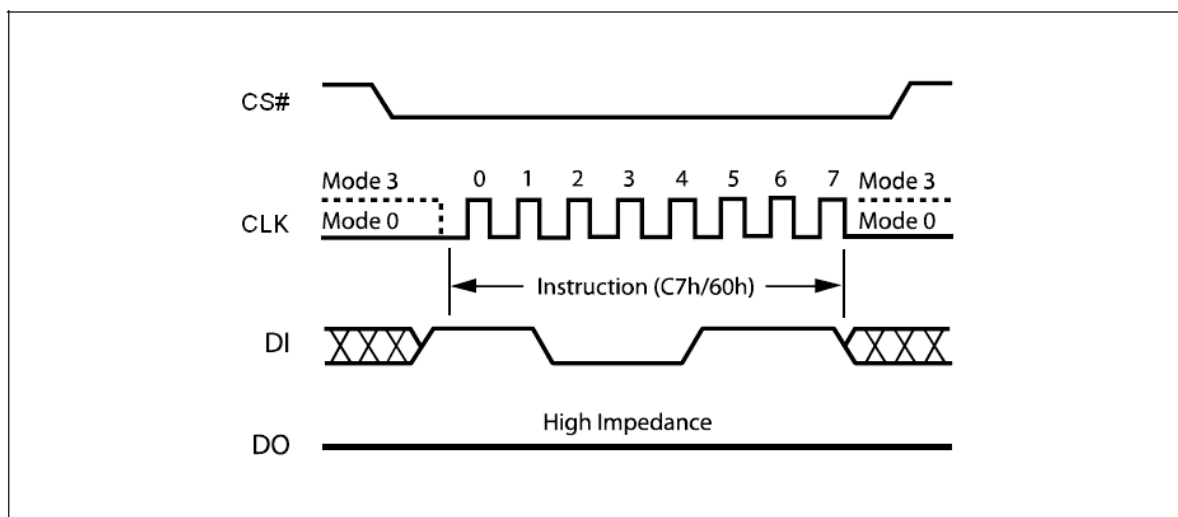

**Figure 25. Chip Erase Instruction Sequence Diagram**

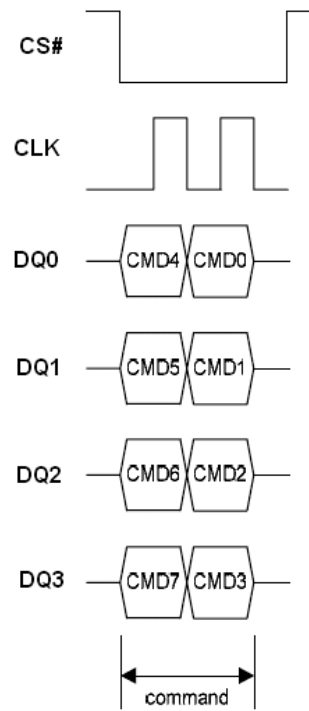

**Figure 25.1 Chip Erase Sequence in QPI Mode**

**Deep Power-down (DP) (B9h)**

Executing the Deep Power-down (DP) instruction is the only way to put the device in the lowest consumption mode (the Deep Power-down mode). It can also be used as an extra software protection mechanism, while the device is not in active use, since in this mode, the device ignores all Write, Program and Erase instructions.

Driving Chip Select (CS#) High deselects the device, and puts the device in the Standby mode (if there is no internal cycle currently in progress). But this mode is not the Deep Power-down mode. The Deep Power-down mode can only be entered by executing the Deep Power-down (DP) instruction, to reduce the standby current (from  $I_{CC1}$  to  $I_{CC2}$ , as specified in Table 13.)

Once the device has entered the Deep Power-down mode, all instructions are ignored except the Release from Deep Power-down and Read Device ID (RDI) instruction. This releases the device from this mode. The Release from Deep Power-down and Read Device ID (RDI) instruction also allows the Device ID of the device to be output on Serial Data Output (DO).

The Deep Power-down mode automatically stops at Power-down, and the device always Powers-up in the Standby mode. The Deep Power-down (DP) instruction is entered by driving Chip Select (CS#) Low, followed by the instruction code on Serial Data Input (DI). Chip Select (CS#) must be driven Low for the entire duration of the sequence.

The instruction sequence is shown in Figure 26. Chip Select (CS#) must be driven High after the eighth bit of the instruction code has been latched in, otherwise the Deep Power-down (DP) instruction is not executed. As soon as Chip Select (CS#) is driven High, it requires a delay of  $t_{DP}$  before the supply current is reduced to  $I_{CC2}$  and the Deep Power-down mode is entered.

Any Deep Power-down (DP) instruction, while an Erase, Program or Write cycle is in progress, is rejected without having any effects on the cycle that is in progress.

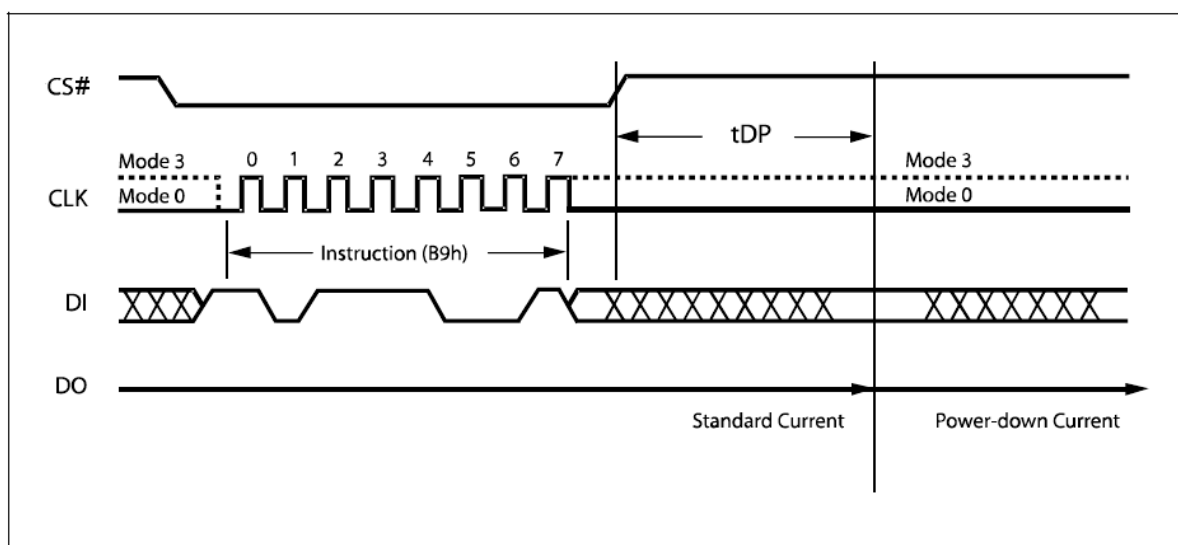

**Figure 26. Deep Power-down Instruction Sequence Diagram**

**Release from Deep Power-down and Read Device ID (RDI)**

Once the device has entered the Deep Power-down mode, all instructions are ignored except the Release from Deep Power-down and Read Device ID (RDI) instruction. Executing this instruction takes the device out of the Deep Power-down mode.

Please note that this is not the same as, or even a subset of, the JEDEC 16-bit Electronic Signature that is read by the Read Identifier (RDID) instruction. The old-style Electronic Signature is supported for reasons of backward compatibility, only, and should not be used for new designs. New designs should, instead, make use of the JEDEC 16-bit Electronic Signature, and the Read Identifier (RDID) instruction.

When used only to release the device from the power-down state, the instruction is issued by driving the CS# pin low, shifting the instruction code "ABh" and driving CS# high as shown in Figure 27. After the time duration of  $t_{RES1}$  (See AC Characteristics) the device will resume normal operation and other instructions will be accepted. The CS# pin must remain high during the  $t_{RES1}$  time duration.

When used only to obtain the Device ID while not in the power-down state, the instruction is initiated by driving the CS# pin low and shifting the instruction code "ABh" followed by 3-dummy bytes. The Device ID bits are then shifted out on the falling edge of CLK with most significant bit (MSB) first as shown in Figure 28. The Device ID values for the device are listed in Table 6. The Device ID can be read continuously. The instruction is completed by driving CS# high.

When Chip Select (CS#) is driven High, the device is put in the Stand-by Power mode. If the device was not previously in the Deep Power-down mode, the transition to the Stand-by Power mode is immediate. If the device was previously in the Deep Power-down mode, though, the transition to the Standby Power mode is delayed by  $t_{RES2}$ , and Chip Select (CS#) must remain High for at least  $t_{RES2}$  (max), as specified in Table 15. Once in the Stand-by Power mode, the device waits to be selected, so that it can receive, decode and execute instructions.

Except while an Erase, Program or Write Status Register cycle is in progress, the Release from Deep Power-down and Read Device ID (RDI) instruction always provides access to the 8bit Device ID of the device, and can be applied even if the Deep Power-down mode has not been entered.

Any Release from Deep Power-down and Read Device ID (RDI) instruction while an Erase, Program or Write Status Register cycle is in progress, is not decoded, and has no effect on the cycle that is in progress.

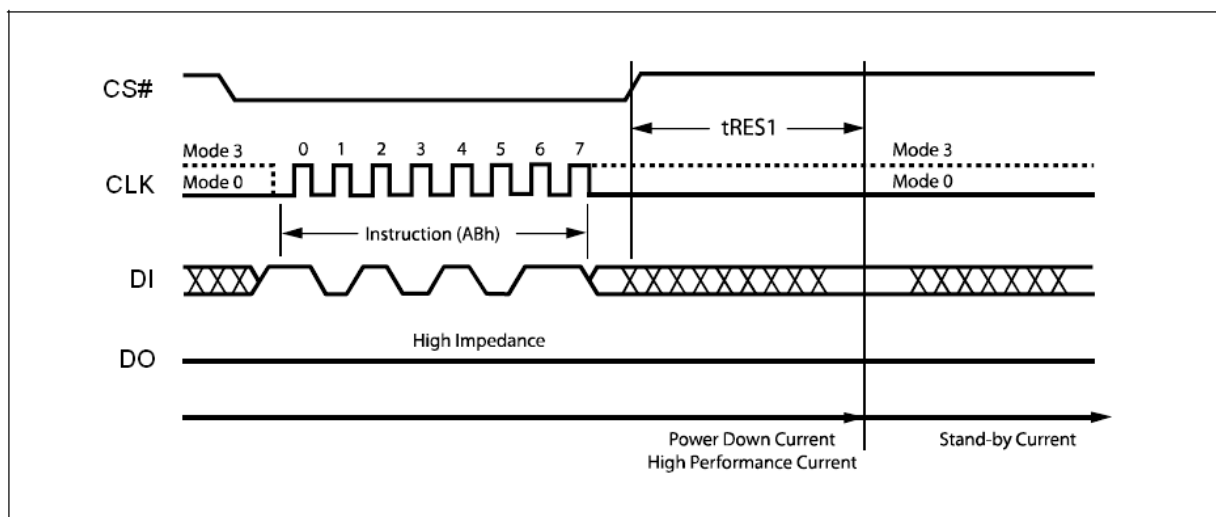

**Figure 27. Release Power-down Instruction Sequence Diagram**

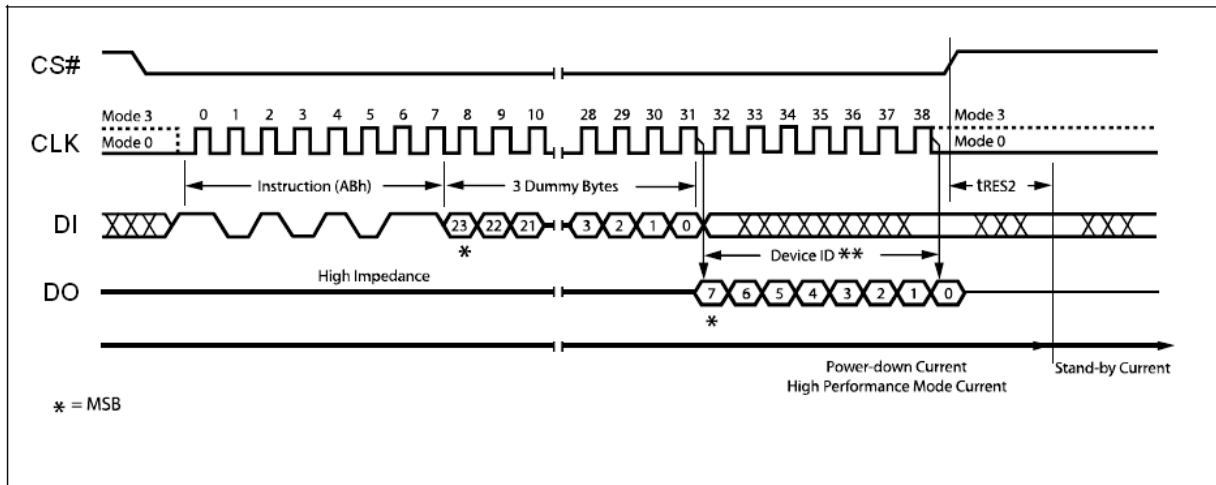

**Figure 28. Release Power-down / Device ID Instruction Sequence Diagram**

**Read Manufacturer / Device ID (90h)**

The Read Manufacturer/Device ID instruction is an alternative to the Release from Power-down / Device ID instruction that provides both the JEDEC assigned manufacturer ID and the specific device ID.

The Read Manufacturer/Device ID instruction is very similar to the Release from Power-down / Device ID instruction. The instruction is initiated by driving the CS# pin low and shifting the instruction code "90h" followed by a 24-bit address of 000000h. After which, the Manufacturer ID for Eon (1Ch) and the Device ID are shifted out on the falling edge of CLK with most significant bit (MSB) first as shown in Figure 29. The Device ID values for the device are listed in Table 6. If the 24-bit address is initially set to 000001h the Device ID will be read first

The instruction sequence is shown in Figure 29.1 while using the Enable Quad Peripheral Interface mode (EQPI) (38h) command.

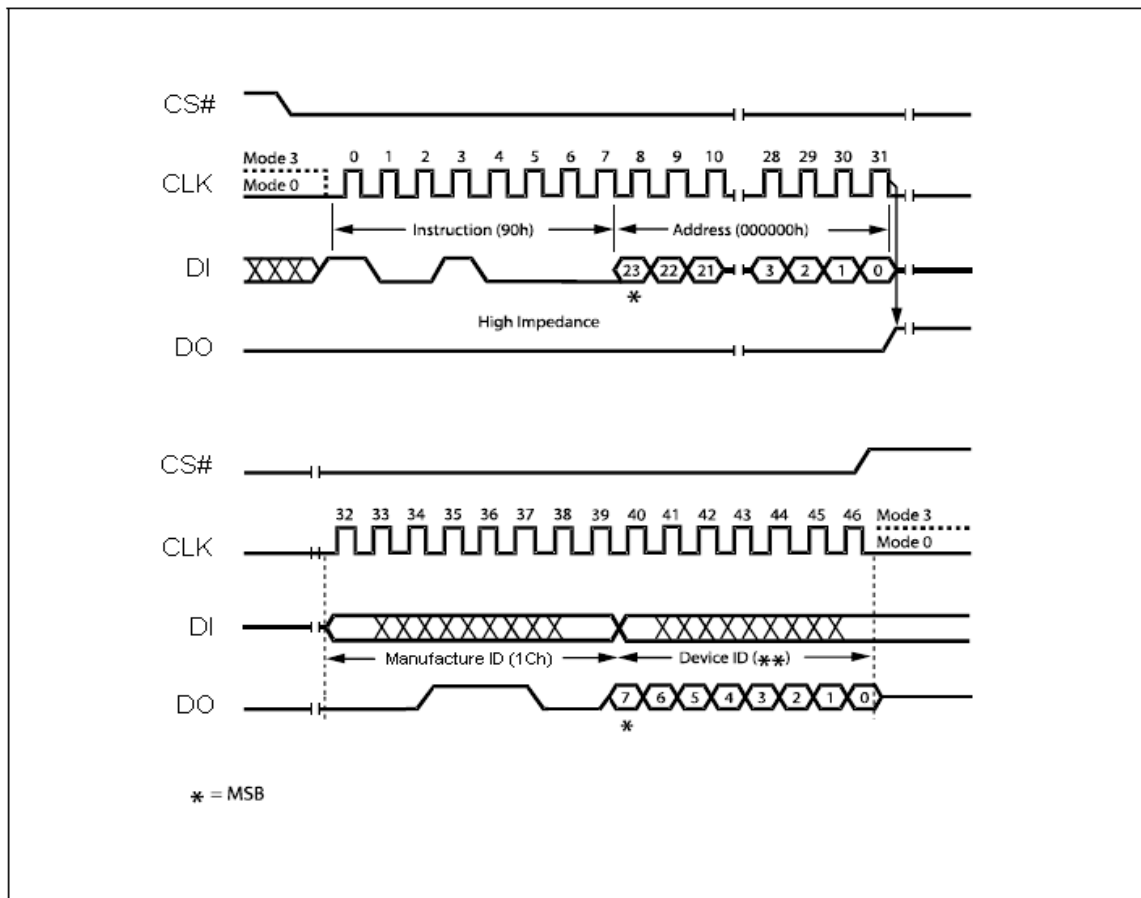

**Figure 29. Read Manufacturer / Device ID Diagram**



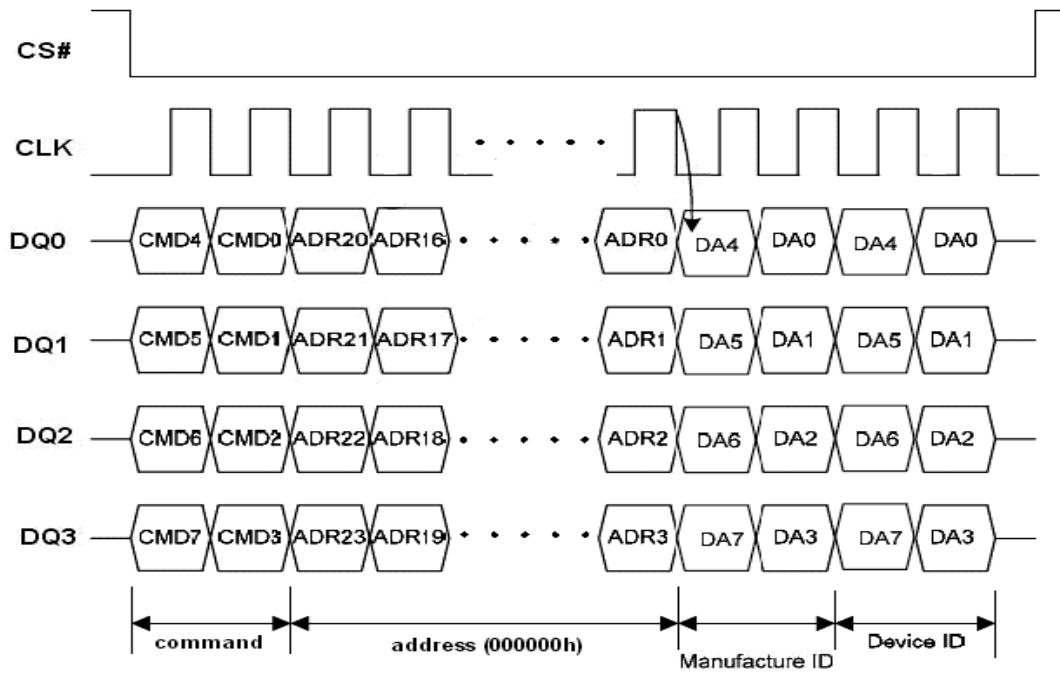

**Figure 29.1 Read Manufacturer / Device ID Diagram in QPI Mode**

**Read Identification (RDID) (9Fh)**

The Read Identification (RDID) instruction allows the 8-bit manufacturer identification to be read, followed by two bytes of device identification. The device identification indicates the memory type in the first byte, and the memory capacity of the device in the second byte.

Any Read Identification (RDID) instruction while an Erase or Program cycle is in progress, is not decoded, and has no effect on the cycle that is in progress. The Read Identification (RDID) instruction should not be issued while the device is in Deep Power down mode.

The device is first selected by driving Chip Select Low. Then, the 8-bit instruction code for the instruction is shifted in. This is followed by the 24-bit device identification, stored in the memory, being shifted out on Serial Data Output, each bit being shifted out during the falling edge of Serial Clock. The instruction sequence is shown in Figure 30. The Read Identification (RDID) instruction is terminated by driving Chip Select High at any time during data output.

When Chip Select is driven High, the device is put in the Standby Power mode. Once in the Standby Power mode, the device waits to be selected, so that it can receive, decode and execute instructions.

The instruction sequence is shown in Figure 30.1 while using the Enable Quad Peripheral Interface mode (EQPI) (38h) command.

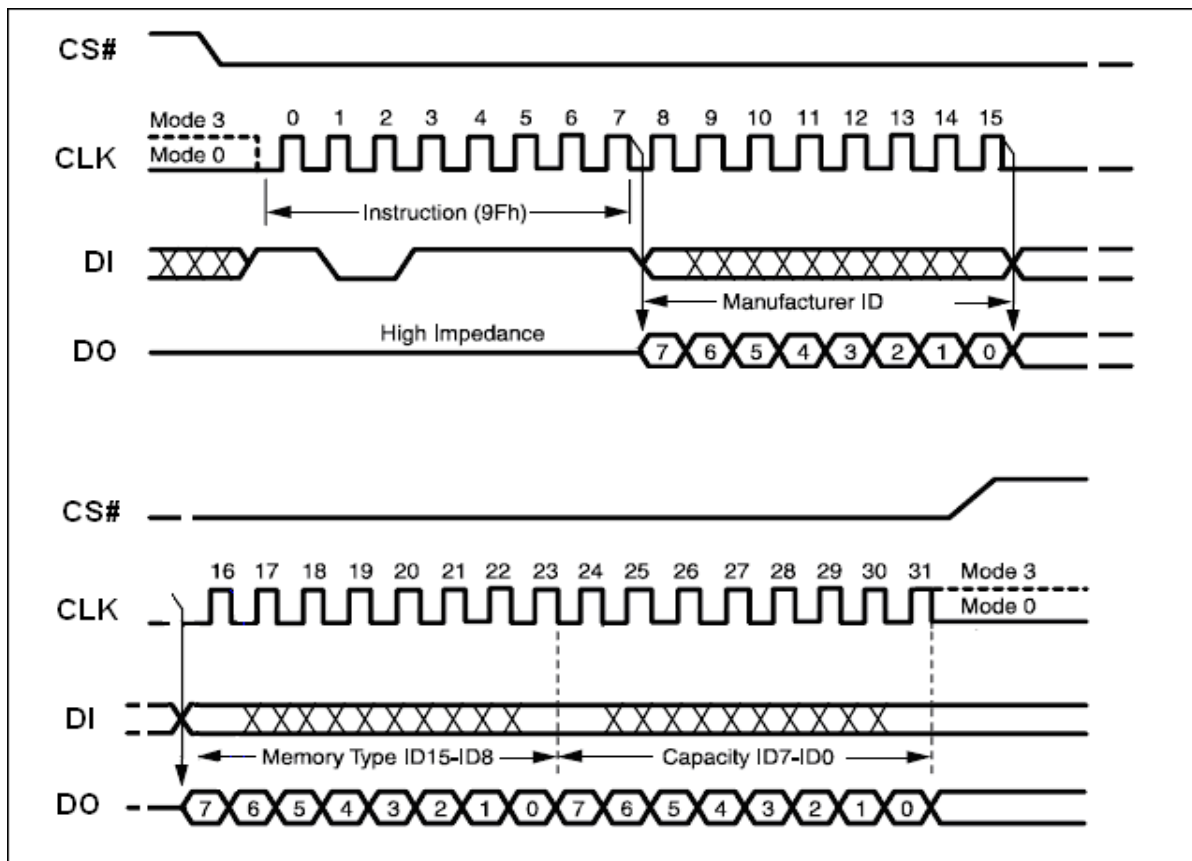

**Figure 30. Read Identification (RDID)**

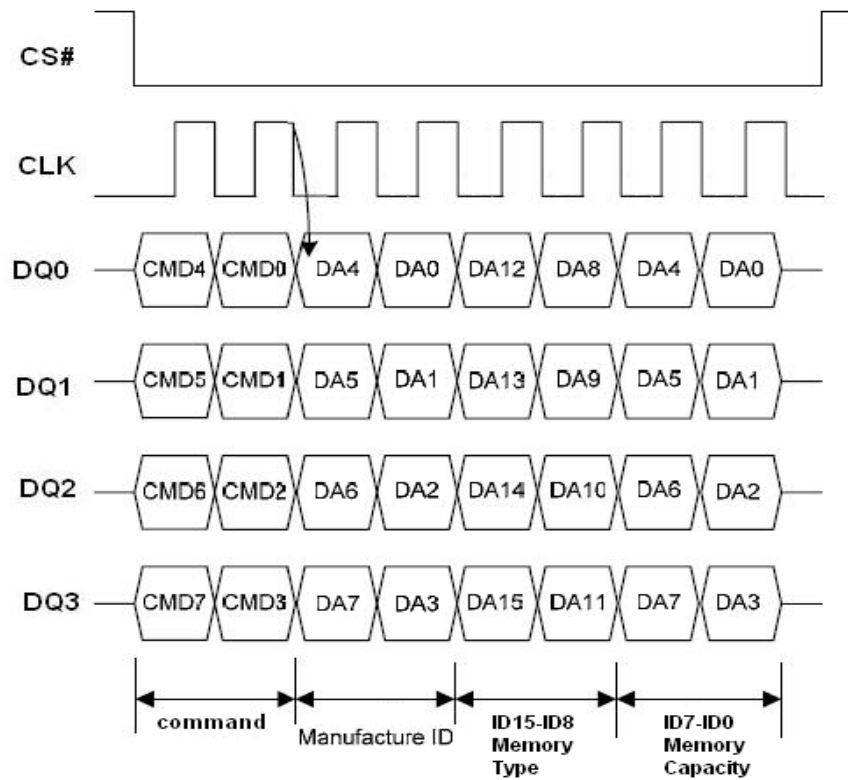

**Figure 30.1. Read Identification (RDID) in QPI Mode**

**Enter OTP Mode (3Ah)**

This Flash support OTP mode to enhance the data protection, user can use the Enter OTP mode (3Ah) command for entering this mode. In OTP mode, the Status Register SR7 bit is served as SPL0 bit; SR4 bit is served as 4KB BL bit, SR3 bit is served as TB bit, SR2 bit is served as SPL1 bit, SR1 bit is served as SPL2 bit and SR0 bit is served as WIP bit. They can be read by RDSR command.

This Flash has extra 3 OTP lockable security sectors, each security sector size is 512 bytes, user must issue ENTER OTP MODE command to read, program or erase OTP sectors. After entering OTP mode, the OTP lockable security sectors are mapping to sector 1023, 1022, and 1021, **PPB bit** becomes SPL0 bit, BP0 bit becomes SPL1 bit, WEL bit becomes SPL2 bit. The Chip Erase, Block Erase and Half Block Erase commands are also disabled.

In OTP mode, user can read other block, but program/erase other block only allowed when they are not protected by Block Protect (BP3, BP2, BP1, BP0) bits and Block Lock feature. The security sectors can **only** be erased by Sector Erase (20h) command. The Chip Erase (C7h/60h), 64k Block Erase(D8h) and 32K Half Block Erase(52h) commands are disable in OTP mode.

**Table 8. OTP Sector Address**

Sector	Sector Size	Address Range
1023	512 byte	3FF000h – 3FF1FFh
1022	512 byte	3FE000h – 3FE1FFh
1021	512 byte	3FD000h – 3FD1FFh

Note: The OTP lockable security sectors are mapping to sector 1023, sector 1022, and sector 1021.

The Enable Boot Lock feature is configured in normal mode. It enables user to lock the 64KB-Block/Sector on the top/bottom of the device for protection. This feature is activated by programming the EBL bit to '1'. WRSR command is used to program SPL0 bit, TB bit, 4KB BL bit, SPL1 bit, and SPL2 bit to '1', but these bits only can be programmed once. User can use WRDI (04h) command to exit OTP mode.

The instruction sequence is shown in Figure 31.1 while using the Enable Quad Peripheral Interface mode (EQPI) (38h) command.

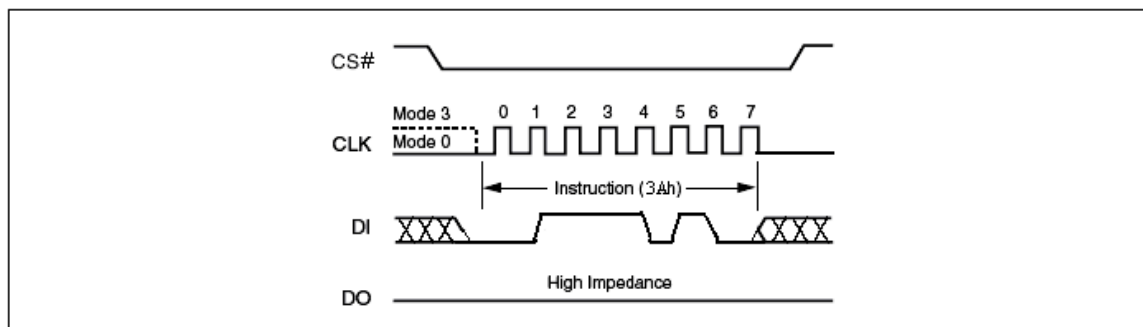
**Figure 31. Enter OTP Mode Sequence**

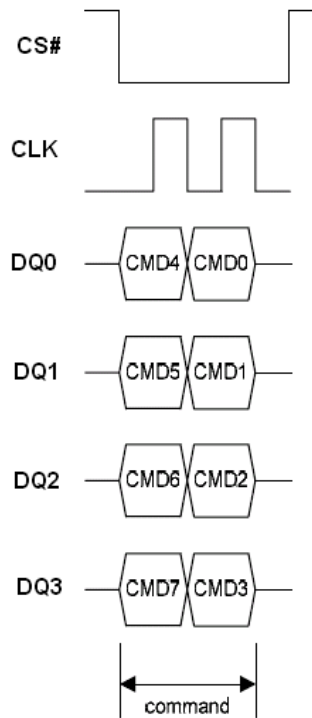

**Figure 31.1 Enter OTP Mode Sequence in QPI Mode**

**Read SFDP Mode and Unique ID Number (5Ah)**
**Read SFDP Mode**

Device features Serial Flash Discoverable Parameters (SFDP) mode. Host system can retrieve the operating characteristics, structure and vendor specified information such as identifying information, memory size, operating voltage and timing information of this device by SFDP mode.

The device is first selected by driving Chip Select (CS#) Low. The instruction code for the Read SFDP Mode is followed by a 3-byte address (A23-A0) and a dummy byte, each bit being latched-in during the rising edge of Serial Clock (CLK). Then the memory contents, at that address, is shifted out on Serial Data Output (DO), each bit being shifted out, at a maximum frequency FR, during the falling edge of Serial Clock (CLK).

The instruction sequence is shown in Figure 32. The first byte addressed can be at any location. The address is automatically incremented to the next higher address after each byte of data is shifted out. The whole memory can, therefore, be read with a single Serial Flash Discoverable Parameters (SFDP) instruction. When the highest address is reached, the address counter rolls over to 0x00h, allowing the read sequence to be continued indefinitely. The Serial Flash Discoverable Parameters (SFDP) instruction is terminated by driving Chip Select (CS#) High. Chip Select (CS#) can be driven High at any time during data output. Any Read Data Bytes at Serial Flash Discoverable Parameters (SFDP) instruction, while an Erase, Program or Write cycle is in progress, is rejected without having any effects on the cycle that is in progress.

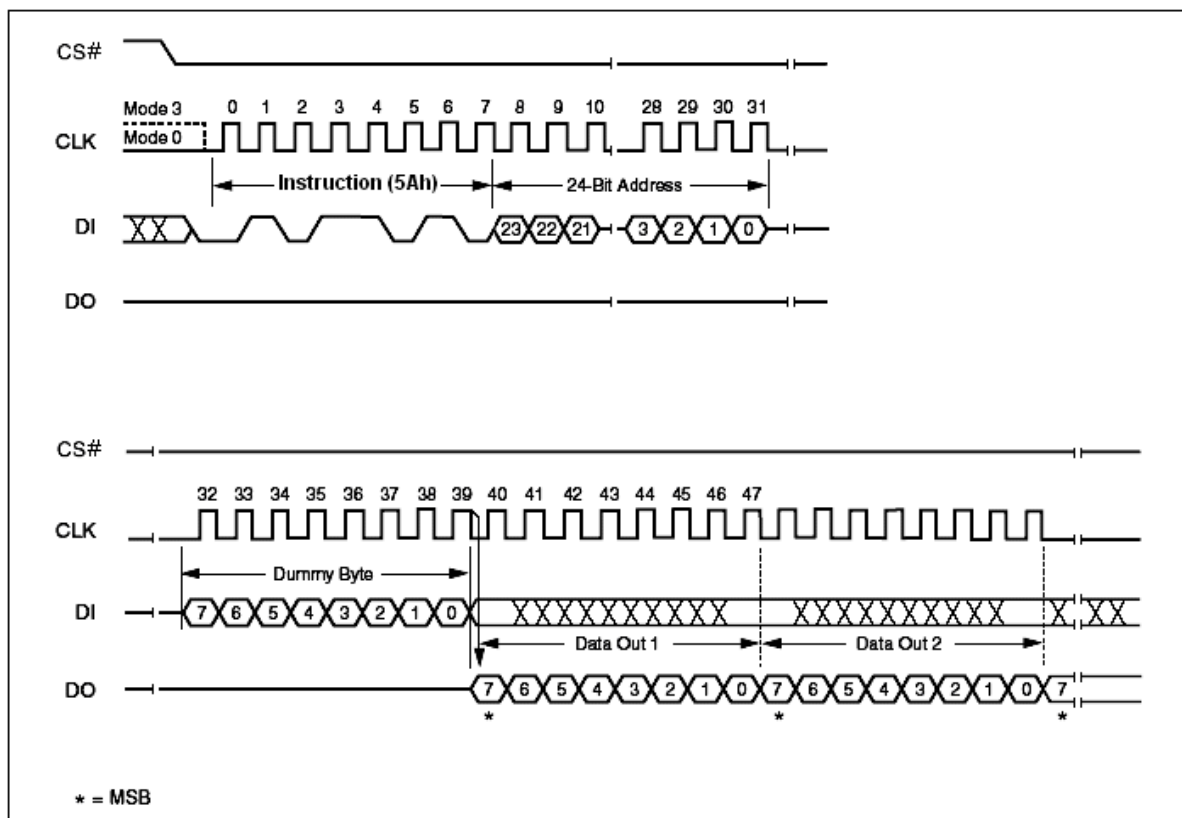

**Figure 32. Read SFDP Mode and Unique ID Number Instruction Sequence Diagram**



Table 9. Serial Flash Discoverable Parameters (SFDP) Signature and Parameter Identification Data Value (Advanced Information)

Description	Address (h) (Byte Mode)	Address (Bit)	Data	Comment
SFDP Signature	00h	07 : 00	53h	Signature [31:0]: Hex: 50444653
	01h	15 : 08	46h	
	02h	23 : 16	44h	
	03h	31 : 24	50h	
SFDP Minor Revision Number	04h	07 : 00	00h	Star from 0x00
SFDP Major Revision Number	05h	15 : 08	01h	Star from 0x01
Number of Parameter Headers (NPH)	06h	23 : 16	00h	1 parameter header
Unused	07h	31 : 24	FFh	Reserved
ID Number	08h	07 : 00	00h	JEDEC ID
Parameter Table Minor Revision Number	09h	15 : 08	00h	Star from 0x00
Parameter Table Major Revision Number	0Ah	23 : 16	01h	Star from 0x01
Parameter Table Length (in DW)	0Bh	31 : 24	09h	9 DWORDs
Parameter Table Pointer (PTP)	0Ch	07 : 00	30h	000030h
	0Dh	15 : 08	00h	
	0Eh	23 : 16	00h	
Unused	0Fh	31 : 24	FFh	Reserved



Table 10. Parameter ID (0) (Advanced Information) 1/9

Description	Address (h) (Byte Mode)	Address (Bit)	Data	Comment	
<b>Block / Sector Erase sizes</b> Identifies the erase granularity for all Flash Components	30h	00	01b	00 = reserved 01 = 4KB erase 10 = reserved 11 = 64KB erase	
		01			
<b>Write Granularity</b>		02	1b	0 = No, 1 = Yes	
<b>Write Enable Instruction Required for Writing to Volatile Status Register</b>		03	01b	00 = N/A 01 = use 50h opcode 11 = use 06h opcode	
<b>Write Enable Opcode Select for Writing to Volatile Status Register</b>		04			
<b>Unused</b>		05	111b	Reserved	
		06			
		07			
<b>4 Kilo-Byte Erase Opcode</b>		31h	08	20h	4 KB Erase Support (FFh = not supported)
			09		
	10				
	11				
	12				
	13				
	14				
<b>Supports (1-1-2) Fast Read</b> Device supports single input opcode & address and dual output data Fast Read	32h	16	1b	0 = not supported 1 = supported	
		<b>Address Byte</b> Number of bytes used in addressing for flash array read, write and erase.	17	00b	00 = 3-Byte 01 = 3- or 4-Byte (e.g. defaults to 3-Byte mode; enters 4-Byte mode on command) 10 = 4-Byte 11 = reserved
18					
<b>Supports Double Transfer Rate (DTR) Clocking</b> Indicates the device supports some type of double transfer rate clocking.		19	0b	0 = not supported 1 = supported	
<b>Supports (1-2-2) Fast Read</b> Device supports single input opcode, dual input address, and dual output data Fast Read		20	1b	0 = not supported 1 = supported	
<b>Supports (1-4-4) Fast Read</b> Device supports single input opcode, quad input address, and quad output data Fast Read		21	1b	0 = not supported 1 = supported	
<b>Supports (1-1-4) Fast Read</b> Device supports single input opcode & address and quad output data Fast Read		22	1b	0 = not supported 1 = supported	
<b>Unused</b>		23	1b	Reserved	
<b>Unused</b>		33h	24	FFh	Reserved
			25		
	26				
	27				
	28				
	29				
	30				
31					





Table 10. Parameter ID (0) (Advanced Information) 2/9

Description	Address (h) (Byte Mode)	Address (Bit)	Data	Comment
Flash Memory Density	37h : 34h	31 : 00	01FFFFFFh	32 Mbits

Table 10. Parameter ID (0) (Advanced Information) 3/9

Description	Address (h) (Byte Mode)	Address (Bit)	Data	Comment
<b>(1-4-4) Fast Read Number of Wait states (dummy clocks) needed before valid output</b>	38h	00	00100b	4 dummy clocks
		01		
		02		
		03		
		04		
<b>Quad Input Address Quad Output (1-4-4) Fast Read Number of Mode Bits</b>	38h	05	010b	8 mode bits
		06		
		07		
<b>(1-4-4) Fast Read Opcode</b> Opcode for single input opcode, quad input address, and quad output data Fast Read.	39h	08	EBh	
		09		
		10		
		11		
		12		
		13		
		14		
<b>(1-1-4) Fast Read Number of Wait states (dummy clocks) needed before valid output</b>	3Ah	16	01000b	8 dummy clocks
		17		
		18		
		19		
<b>(1-1-4) Fast Read Number of Mode Bits</b>	3Ah	20	000b	Not Supported
		21		
		22		
<b>(1-1-4) Fast Read Opcode</b> Opcode for single input opcode & address and quad output data Fast Read.	3Bh	23	6Bh	Not Supported
		31 : 24		



Table 10. Parameter ID (0) (Advanced Information) 4/9

Description	Address (h) (Byte Mode)	Address (Bit)	Data	Comment
<b>(1-1-2) Fast Read Number of Wait states (dummy clocks) needed before valid output</b>	3Ch	00	01000b	8 dummy clocks
		01		
		02		
		03		
		04		
<b>(1-1-2) Fast Read Number of Mode Bits</b>	3Ch	05	000b	Not Supported
		06		
		07		
<b>(1-1-2) Fast Read Opcode</b> Opcode for single input opcode & address and dual output data Fast Read.	3Dh	15 : 08	3Bh	
<b>(1-2-2) Fast Read Number of Wait states (dummy clocks) needed before valid output</b>	3Eh	16	00100b	4 dummy clocks
		17		
		18		
		19		
		20		
<b>(1-2-2) Fast Read Number of Mode Bits</b>	3Eh	21	000b	Not Supported
		22		
		23		
<b>(1-2-2) Fast Read Opcode</b> Opcode for single input opcode, dual input address, and dual output data Fast Read.	3Fh	31 : 24	BBh	

Table 10. Parameter ID (0) (Advanced Information) 5/9

Description	Address (h) (Byte Mode)	Address (Bit)	Data	Comment
<b>Supports (2-2-2) Fast Read</b> Device supports dual input opcode & address and dual output data Fast Read.	40h	00	0b	0 = not supported 1 = supported
Reserved. These bits default to all 1's		01	111b	Reserved
		02		
		03		
<b>Supports (4-4-4) Fast Read</b> Device supports Quad input opcode & address and quad output data Fast Read.		04	1b	0 = not supported 1 = supported (QPI Mode)
Reserved. These bits default to all 1's		05	111b	Reserved
		06		
		07		
Reserved. These bits default to all 1's	43h : 41h	31 : 08	FFFFFFh	Reserved



Table 10. Parameter ID (0) (Advanced Information) 6/9

Description	Address (h) (Byte Mode)	Address (Bit)	Data	Comment
Reserved. These bits default to all 1's	45h : 44h	15 : 00	FFFFh	Reserved
(2-2-2) Fast Read Number of Wait states (dummy clocks) needed before valid output	46h	16	00000b	Not Supported
		17		
		18		
		19		
(2-2-2) Fast Read Number of Mode Bits	46h	20	000b	Not Supported
		21		
		22		
(2-2-2) Fast Read Opcode Opcode for dual input opcode & address and dual output data Fast Read.	47h	23	FFh	Not Supported
		31 : 24		

Table 10. Parameter ID (0) (Advanced Information) 7/9

Description	Address (h) (Byte Mode)	Address (Bit)	Data	Comment
Reserved. These bits default to all 1's	49h : 48h	15 : 00	FFFFh	Reserved
(4-4-4) Fast Read Number of Wait states (dummy clocks) needed before valid output	4Ah	16	00100b	4 dummy clocks
		17		
		18		
		19		
(4-4-4) Fast Read Number of Mode Bits	4Ah	20	010b	8 mode bits
		21		
		22		
(4-4-4) Fast Read Opcode Opcode for quad input opcode/address, quad output data Fast Read.	4Bh	23	EBh	Must Enter QPI Mode Firstly
		31 : 24		

Table 10. Parameter ID (0) (Advanced Information) 8/9

Description	Address (h) (Byte Mode)	Address (Bit)	Data	Comment
Sector Type 1 Size	4Ch	07 : 00	0Ch	4 KB
Sector Type 1 Opcode	4Dh	15 : 08	20h	
Sector Type 2 Size	4Eh	23 : 16	0Fh	32 KB
Sector Type 2 Opcode	4Fh	31 : 24	52h	

Table 10. Parameter ID (0) (Advanced Information) 9/9

Description	Address (h) (Byte Mode)	Address (Bit)	Data	Comment
Sector Type 3 Size	50h	07 : 00	10h	64 KB
Sector Type 3 Opcode	51h	15 : 08	D8h	
Sector Type 4 Size	52h	23 : 16	00h	Not Supported
Sector Type 4 Opcode	53h	31 : 24	FFh	Not Supported



### Read Unique ID Number

The Read Unique ID Number instruction accesses a factory-set read-only 96-bit number that is unique to each device. The ID number can be used in conjunction with user software methods to help prevent copying or cloning of a system. The Read Unique ID instruction is initiated by driving the CS# pin low and shifting the instruction code "5Ah" followed by a three bytes of addresses, 0x80h, and one byte of dummy clocks. After which, the 96-bit ID is shifted out on the falling edge of CLK.

Table 11. Unique ID Number

Description	Address (h) (Byte Mode)	Address (Bit)	Data	Comment
Unique ID Number	80h : 8Bh	95 : 00	By die	

### Power-up Timing

All functionalities and DC specifications are specified for a V<sub>CC</sub> ramp rate of greater than 1V per 100 ms (0V to 2.7V in less than 270 ms). See Table 12 and Figure 33 for more information.

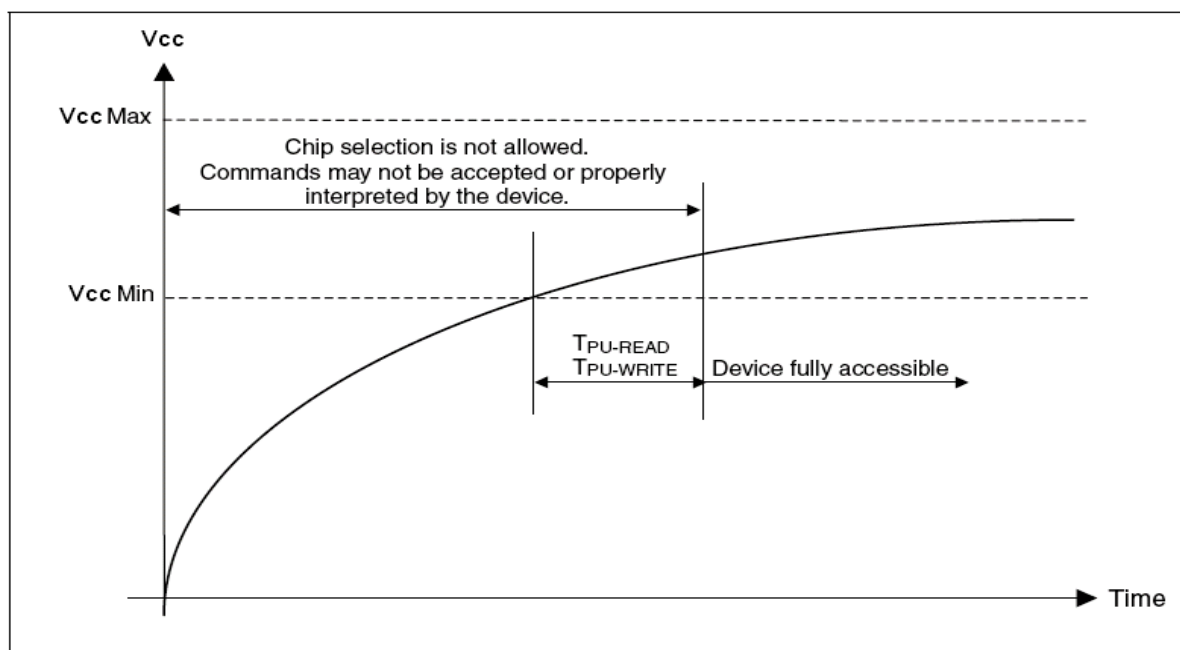

Figure 33. Power-up Timing

Table 12. Power-Up Timing

Symbol	Parameter	Min.	Unit
T <sub>PU-READ</sub> <sup>(1)</sup>	V <sub>CC</sub> Min to Read Operation	100	µs
T <sub>PU-WRITE</sub> <sup>(1)</sup>	V <sub>CC</sub> Min to Write Operation	100	µs

**Note:**

- 1. This parameter is measured only for initial qualification and after a design or process change that could affect this parameter.

**INITIAL DELIVERY STATE**

The device is delivered with the memory array erased: all bits are set to 1 (each byte contains FFh). The Status Register contains 00h (all Status Register bits are 0).

**Table 13. DC Characteristics**

( $T_A = -40^{\circ}\text{C}$  to  $85^{\circ}\text{C}$ ;  $V_{CC} = 2.7\text{-}3.6\text{V}$ )

Symbol	Parameter	Test Conditions	Min.	Typ.	Max.	Unit
$I_{LI}$	Input Leakage Current		-	1	$\pm 2$	$\mu\text{A}$
$I_{LO}$	Output Leakage Current		-	1	$\pm 2$	$\mu\text{A}$
$I_{CC1}$	Standby Current	$CS\# = V_{CC}$ , $V_{IN} = V_{SS}$ or $V_{CC}$	-	1	20	$\mu\text{A}$
$I_{CC2}$	Deep Power-down Current	$CS\# = V_{CC}$ , $V_{IN} = V_{SS}$ or $V_{CC}$	-	1	20	$\mu\text{A}$
$I_{CC3}$	Operating Current (READ)	CLK = $0.1 V_{CC}$ / $0.9 V_{CC}$ at 104MHz, DQ = open	-	5	10	mA
		CLK = $0.1 V_{CC}$ / $0.9 V_{CC}$ at 104MHz in Quad mode, DQ = open	-	14	18	mA
$I_{CC4}$	Operating Current (PP)	$CS\# = V_{CC}$	-	9	20	mA
$I_{CC5}$	Operating Current (WRSR)	$CS\# = V_{CC}$	-		12	mA
$I_{CC6}^1$	Operating Current (SE)	$CS\# = V_{CC}$	-	9	20	mA
$I_{CC7}^1$	Operating Current (BE)	$CS\# = V_{CC}$	-	9	20	mA
$V_{IL}$	Input Low Voltage		-0.5		$0.2 V_{CC}$	V
$V_{IH}$	Input High Voltage		$0.7V_{CC}$		$V_{CC}+0.4$	V
$V_{OL}$	Output Low Voltage	$I_{OL} = 100 \mu\text{A}$ , $V_{CC}=V_{CC}$ Min.	-		0.3	V
$V_{OH}$	Output High Voltage	$I_{OH} = -100 \mu\text{A}$ , $V_{CC}=V_{CC}$ Min	$V_{CC}-0.2$		-	V

Note:

- Erase current measure on all cells = '0' state.

**Table 14. AC Measurement Conditions**

Symbol	Parameter	Min.	Max.	Unit
$C_L$	Load Capacitance	30		pF
	Input Rise and Fall Times		5	ns
	Input Pulse Voltages	$0.2V_{CC}$ to $0.8V_{CC}$		V
	Input Timing Reference Voltages	$0.3V_{CC}$ to $0.7V_{CC}$		V
	Output Timing Reference Voltages	$V_{CC} / 2$		V

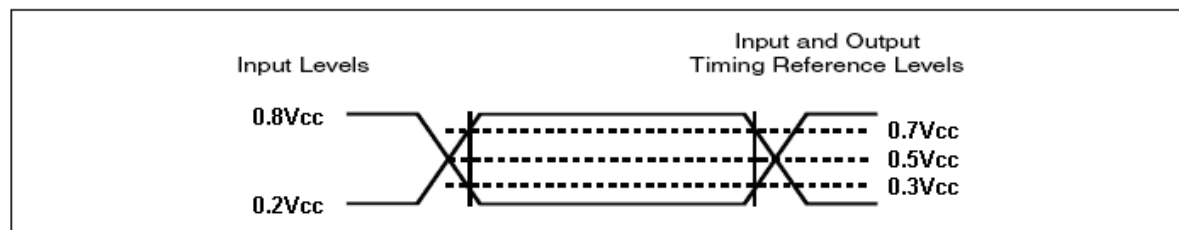
**Figure 34. AC Measurement I/O Waveform**



**Table 15. AC Characteristics**

(T<sub>A</sub> = -40°C to 85°C; V<sub>CC</sub> = 2.7-3.6V)

Symbol	Alt	Parameter	Min	Typ	Max	Unit	
F <sub>R</sub>	f <sub>C</sub>	Serial Clock Frequency for: FAST_READ, QPP, PP, SE, HBE, BE, DP, RES, WREN, WRDI, WRSR, RDSR	D.C.	-	104	MHz	
		Serial Clock Frequency for: RDID, Dual Output Fast Read and Quad I/O Fast Read	D.C.	-	104	MHz	
f <sub>R</sub>		Serial Clock Frequency for READ	D.C.	-	50	MHz	
t <sub>CH</sub> <sup>1</sup>		Serial Clock High Time	3.5	-	-	ns	
t <sub>CL</sub> <sup>1</sup>		Serial Clock Low Time	3.5	-	-	ns	
t <sub>CLCH</sub> <sup>2</sup>		Serial Clock Rise Time (Slew Rate)	0.1	-	-	V / ns	
t <sub>CHCL</sub> <sup>2</sup>		Serial Clock Fall Time (Slew Rate)	0.1	-	-	V / ns	
t <sub>SLCH</sub>	t <sub>CSS</sub>	CS# Active Setup Time (Relative to CLK)	5	-	-	ns	
t <sub>CHSH</sub>		CS# Active Hold Time (Relative to CLK)	5	-	-	ns	
t <sub>SHCH</sub>		CS# Not Active Setup Time (Relative to CLK)	5	-	-	ns	
t <sub>CHSL</sub>		CS# Not Active Hold Time (Relative to CLK)	5	-	-	ns	
t <sub>SHSL</sub>	t <sub>CSH</sub>	CS# High Time	30	-	-	ns	
t <sub>SHQZ</sub> <sup>2</sup>	t <sub>DIS</sub>	Output Disable Time	-	-	6	ns	
t <sub>CLQX</sub>	t <sub>HO</sub>	Output Hold Time	0	-	-	ns	
t <sub>DVCH</sub>	t <sub>DSU</sub>	Data In Setup Time	2	-	-	ns	
t <sub>CHDX</sub>	t <sub>DH</sub>	Data In Hold Time	5	-	-	ns	
t <sub>CLQV</sub>	t <sub>V</sub>	Output Valid from CLK for 30 pF Output Valid from CLK for 15 pF	-	-	8 6	ns	
t <sub>WHSL</sub> <sup>3</sup>		Write Protect Setup Time before CS# Low	20	-	-	ns	
t <sub>SHWL</sub> <sup>3</sup>		Write Protect Hold Time after CS# High	100	-	-	ns	
t <sub>DP</sub> <sup>2</sup>		CS# High to Deep Power-down Mode	-	-	3	µs	
t <sub>RES1</sub> <sup>2</sup>		CS# High to Standby Mode without Electronic Signature read	-	-	3	µs	
t <sub>RES2</sub> <sup>2</sup>		CS# High to Standby Mode with Electronic Signature read	-	-	1.8	µs	
t <sub>W</sub>		Write Status Register Cycle Time	-	4	30	ms	
t <sub>PP</sub>		Page Programming Time	-	0.5	3	ms	
t <sub>SE</sub>		Sector Erase Time	-	0.05	0.3	s	
t <sub>HBE</sub>		32KB Block Erase Time	-	0.12	1	s	
t <sub>BE</sub>		64KB Block Erase Time	-	0.15	2	s	
t <sub>CE</sub>		Chip Erase Time	-	15	50	s	
t <sub>SR</sub>		Software Reset Latency	WIP = write operation	-	-	28	µs
			WIP = not in write operation	-	-	0	µs

**Note:**

- t<sub>CH</sub> + t<sub>CL</sub> must be greater than or equal to 1/ f<sub>C</sub>.
- Value guaranteed by characterization, not 100% tested in production.
- Only applicable as a constraint for a Write status Register instruction when Status Register Protect Bit is set at 1.

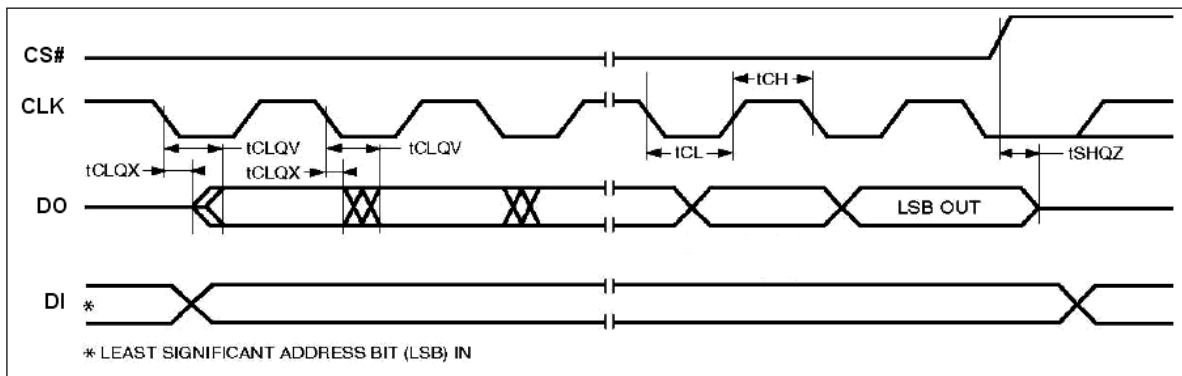
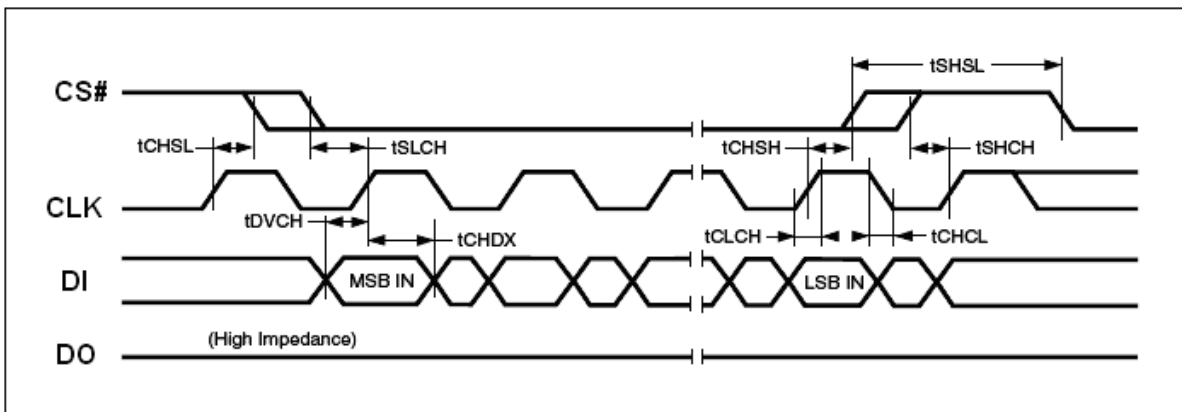
**Figure 35. Serial Output Timing**

**Figure 36. Input Timing**

## ABSOLUTE MAXIMUM RATINGS

Stresses above the values so mentioned above may cause permanent damage to the device. These values are for a stress rating only and do not imply that the device should be operated at conditions up to or above these values. Exposure of the device to the maximum rating values for extended periods of time may adversely affect the device reliability.

Parameter	Value	Unit
Storage Temperature	-65 to +150	°C
Plastic Packages	-65 to +125	°C
Output Short Circuit Current <sup>1</sup>	200	mA
Input and Output Voltage (with respect to ground) <sup>2</sup>	-0.5 to +4.0	V
V <sub>CC</sub>	-0.5 to +4.0	V

Notes:

1. No more than one output shorted at a time. Duration of the short circuit should not be greater than one second.
2. Minimum DC voltage on input or I/O pins is -0.5 V. During voltage transitions, inputs may undershoot V<sub>SS</sub> to -1.0V for periods of up to 50ns and to -2.0 V for periods of up to 20ns. See figure below. Maximum DC voltage on output and I/O pins is V<sub>CC</sub> + 0.5 V. During voltage transitions, outputs may overshoot to V<sub>CC</sub> + 1.5 V for periods up to 20ns. See figure below.

## RECOMMENDED OPERATING RANGES<sup>1</sup>

Parameter	Value	Unit
Ambient Operating Temperature Industrial Devices	-40 to 85	°C
Operating Supply Voltage V <sub>CC</sub>	Full: 2.7 to 3.6	V

Notes: Recommended Operating Ranges define those limits between which the functionality of the device is guaranteed.

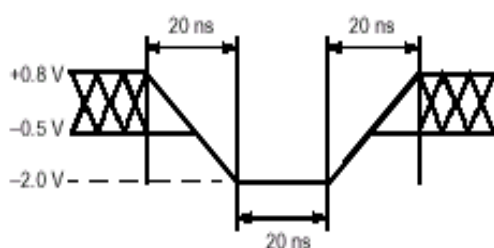

Maximum Negative Overshoot Waveform

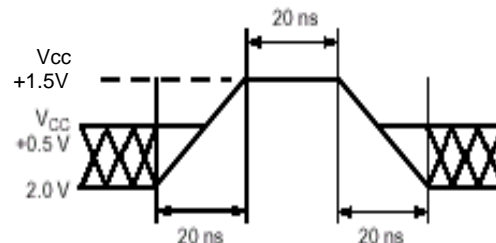

Maximum Positive Overshoot Waveform



**Table 16. CAPACITANCE** $(V_{CC} = 2.7-3.6V)$ 

Parameter Symbol	Parameter Description	Test Setup	Max	Unit
$C_{IN}$	Input Capacitance	$V_{IN} = 0$	6	pF
$C_{OUT}$	Output Capacitance	$V_{OUT} = 0$	8	pF

**Note:** Sampled only, not 100% tested, at  $T_A = 25^\circ C$  and a frequency of 20MHz.

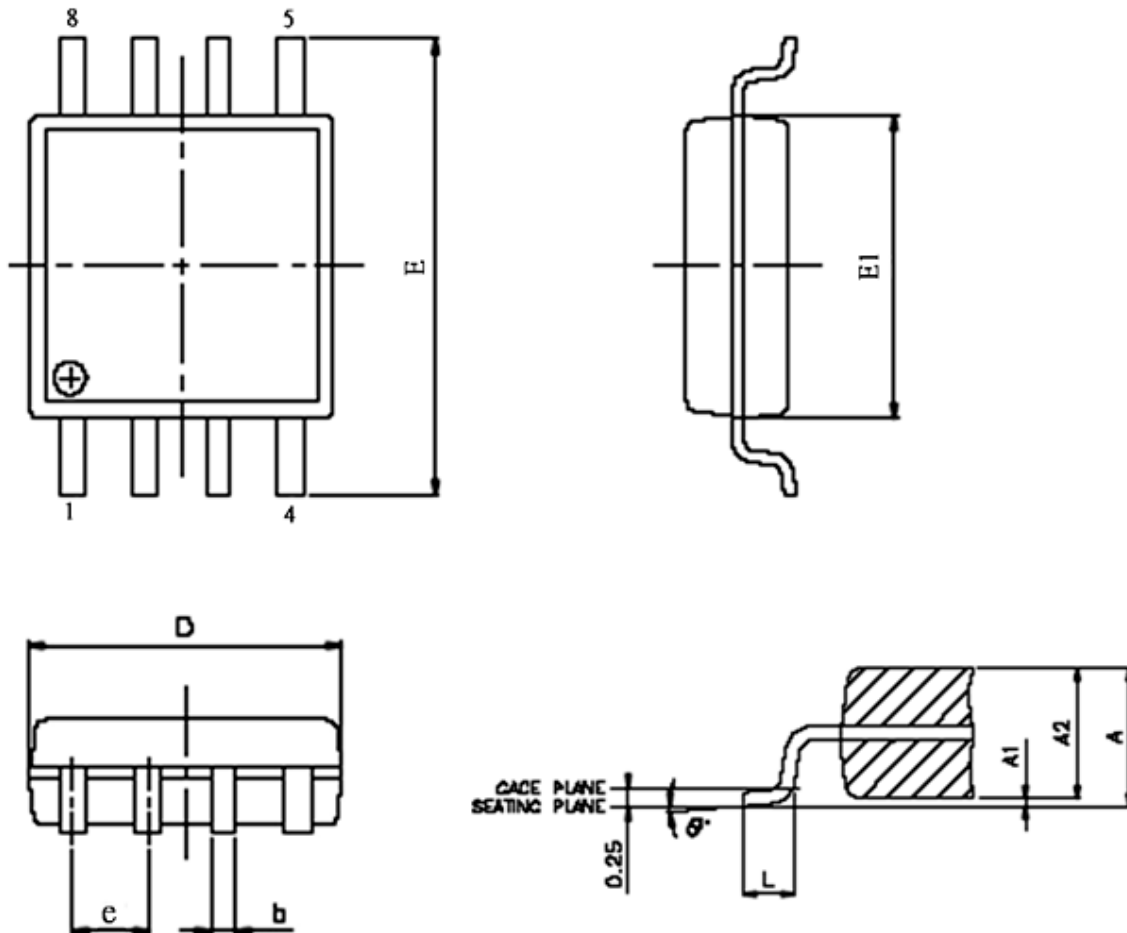
**PACKAGE MECHANICAL**
**Figure 37. SOP 200 mil ( official name = 208 mil )**

SYMBOL	DIMENSION IN MM		
	MIN.	NOR	MAX
A	1.75	1.975	2.20
A1	0.05	0.15	0.25
A2	1.70	1.825	1.95
D	5.15	5.275	5.40
E	7.70	7.90	8.10
E1	5.15	5.275	5.40
e	---	1.27	---
b	0.35	0.425	0.50
L	0.5	0.65	0.80
$\theta$	$0^{\circ}$	$4^{\circ}$	$8^{\circ}$

Note : 1. Coplanarity: 0.1 mm

2. Max. allowable mold flash is 0.15 mm  
at the pkg ends, 0.25 mm between leads.

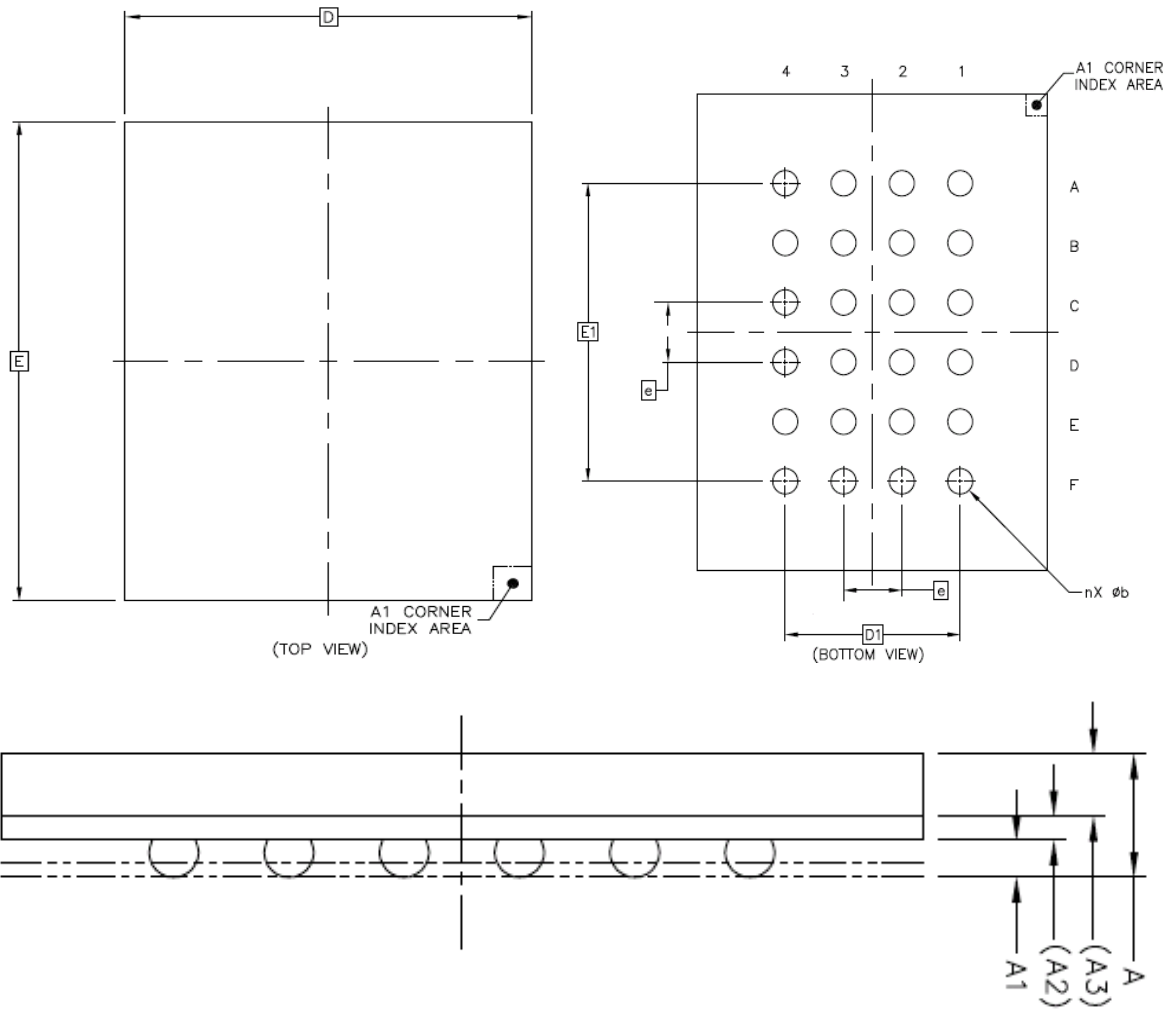
**Figure 38. 24-ball Thin Profile Fine-Pitch Ball Grid Array (6 x 8 mm) Package**

SYMBOL	DIMENSION IN MM		
	MIN.	NOR	MAX
A	---	---	1.20
A1	0.27	---	0.37
A2	0.21 REF		
A3	0.54 REF		
D	6 BSC		
E	8 BSC		
D1	---	3.00	---
E1	---	5.00	---
e	---	1.00	---
b	---	0.40	---

**Note : 1. Coplanarity: 0.1 mm**



**ORDERING INFORMATION**

EN25QA32B - 104 H I P 2C

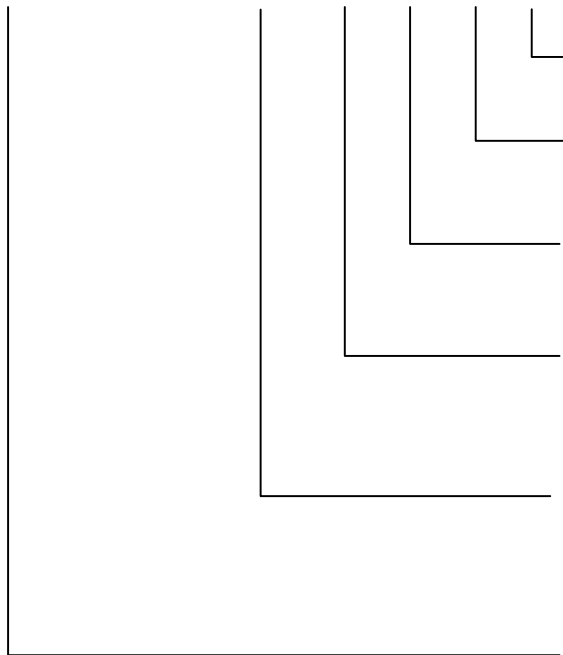

**DIFFERENTIATION CODE**

**PACKAGING CONTENT**

P = RoHS, Halogen-Free and REACH compliant

**TEMPERATURE RANGE**

I = Industrial (-40°C to +85°C)

**PACKAGE**

H = 8-pin 200mil SOP  
BB = 24-ball TFBGA (6 x 8 x 1.2mm)

**SPEED**

104 = 104 MHz

**BASE PART NUMBER**

EN = Eon Silicon Solution Inc.  
25QA = 3V Serial Flash with 4KB Uniform-Sector,  
Dual and Quad I/O  
32 = 32 Megabit (4096K x 8)  
B = version identifier



**Revisions List**

<b>Revision No</b>	<b>Description</b>	<b>Date</b>
Preliminary 0.1	Initial Release	2017/10/05
1.0	Delete "Preliminary"	2017/11/14
1.1	1. Modify the specification of SFDP 2. AddQuad Output Fast Read	2018/01/08