



# EN6338QI 3A PowerSoC

## Step-Down DC-DC Switching Converter with Integrated Inductor

### DESCRIPTION

The EN6338QI is a Power System on a Chip (PowerSoC) DC-DC converter. It integrates MOSFET switches, small-signal circuits, compensation, and the inductor in an advanced 3.75mm x 3.75mm x 1.9mm 19-pin LGA package.

The EN6338QI is specifically designed to meet the precise voltage and fast transient requirements of present and future high-performance, low-power processor, DSP, FPGA, memory boards and system level applications in distributed power architecture. The device's advanced circuit techniques, ultra high switching frequency, and proprietary integrated inductor technology deliver high-quality, ultra compact, non-isolated DC-DC conversion.

The Intel Enpirion power solution significantly helps in system design and productivity by offering greatly simplified board design, layout and manufacturing requirements. In addition, a reduction in the number of vendors required for the complete power solution helps to enable an overall system cost savings.

All Enpirion products are RoHS compliant and lead-free manufacturing environment compatible.

### FEATURES

- High Efficiency (Up to 96%)
- Light Load Mode Operation (LLM)
- Excellent Ripple and EMI Performance
- Up to 3A Continuous Operating Current
- 2.7V to 6.6V Input Voltage Range
- 1.5%  $V_{OUT}$  Accuracy (Load, Temp)
- 1.9MHz Switching Frequency
- 45mm<sup>2</sup> Optimized Total Solution Size
- Programmable Soft-Start
- Power OK Indicator
- Thermal, Over-Current, Short Circuit and Under-Voltage Protection
- RoHS Compliant, MSL Level 3, 260°C Reflow

### APPLICATIONS

- Point of Load Regulation for FPGAs, Distributed Power Architectures, Low-Power ASICs, Multi-Core, Communication Processors and DSPs
- Space Constrained Applications Needing High Power Density
- 5V/3.3V Bus Architectures Needing High Efficiency

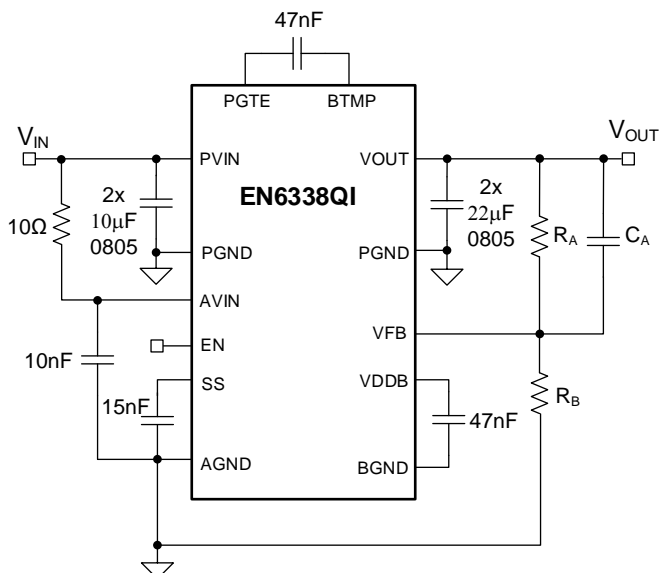


Figure 1: Simplified Applications Circuit

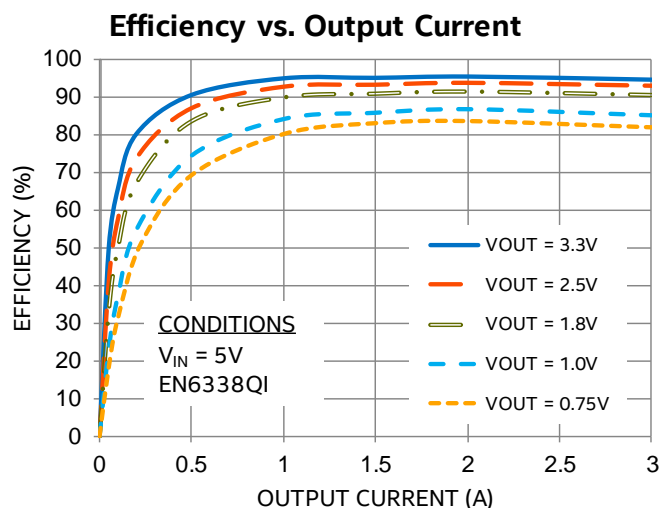


Figure 2: Efficiency at  $V_{IN} = 5V$

## ORDERING INFORMATION

Part Number	Package Markings	T <sub>J</sub> Rating	Package Description
EN6338QI	EN6338QI	-40°C to +125°C	19-pin (3.75mm x 3.75mm x 1.9mm) LGA
EVB-EN6338QI	EN6338QI	LGA Evaluation Board	

### Packing and Marking Information:

<https://www.intel.com/content/www/us/en/programmable/support/quality-and-reliability/packing.html>

## PIN FUNCTIONS

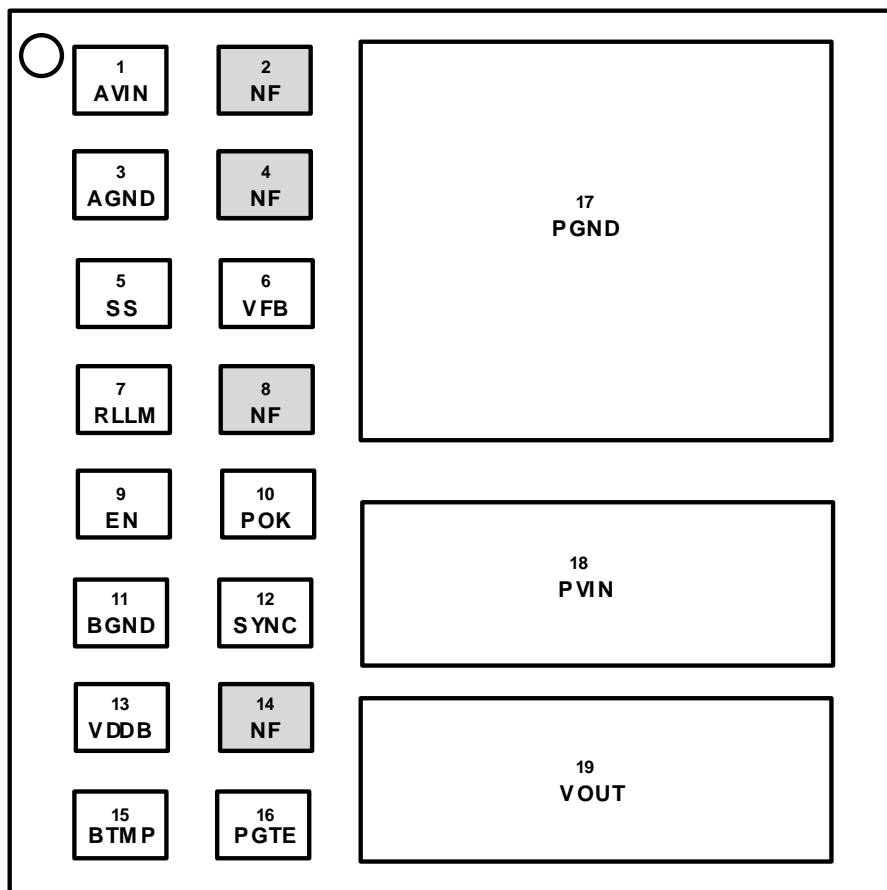


Figure 3: Pin Diagram (Top View)

**NOTE A:** NF pins are non-functional and unconnected internally. Area under NF pin locations may be used for vias to route VFB, POK and SYNC signals. NF pins do not require landing pads.

**NOTE B:** White 'dot' on top left is pin 1 indicator on top of the device package.

## PIN DESCRIPTIONS

PIN	NAME	TYPE	FUNCTION
1	AVIN	Power	Input power supply for the controller. Connect to input voltage at a quiet point.
2, 4, 8, 14	NF	-	NON FUNCTIONAL – These pins are not internally connected and do not require landing pads. Area below these pins may be used for vias to route VFB, POK and SYNC signals to other layers.
3	AGND	Ground	Analog Ground. This is the controller ground return. Connect to a quiet ground.
5	SS	Analog	Soft-Start node. The soft-start capacitor is connected between this pin and AGND. The value of this capacitor determines the startup time.
6	VFB	Analog	This is the external feedback input pin. A resistor divider connects from the output to AGND. The mid-point of the resistor divider is connected to VFB. A feed-forward capacitor ( $C_A$ ) and resistor ( $R_C$ ) are required parallel to the upper feedback resistor ( $R_A$ ). The output voltage regulation is based on the VFB node voltage equal to 0.600V.
7	RLLM	Analog	Programmable LLM engage resistor to AGND allows for adjustment of load current at which Light-Load Mode engages. Can be left open for PWM only operation.
9	EN	Analog	Input Enable. Applying logic high enables the output and initiates a soft-start. Applying logic low disables the output.
10	POK	Digital	Power OK is an open drain transistor used for power system state indication. POK is logic high when VOUT is within -10% of VOUT nominal.
11	BGND	Ground	Ground for VDDDB. Do not connect to external ground.
12	SYNC	Analog	Dual function pin providing LLM Enable and External Clock Synchronization (see Application Section). At static Logic HIGH, device will allow automatic engagement of light load mode. At static logic LOW, the device is forced into PWM only. A clocked input to this pin will synchronize the internal switching frequency to the external signal. If this pin is left floating, it will pull to a static logic high, enabling LLM.
13	VDDDB	Analog	Internal regulated voltage used for the internal control circuitry.
15	BTMP	Ground	Bottom plate ground for PGTE.
16	PGTE	Analog	PMOS gate.
17	PGND	Ground	Input/Output power ground. Connect to the ground electrode of the input and output filter capacitors. See VOUT and PVIN pin descriptions for more details.

PIN	NAME	TYPE	FUNCTION
18	PVIN	Power	Input power supply. Connect to input power supply. Decouple with input capacitor to PGND pin.
19	VOUT	Power	Regulated converter output. Connect to the load and place output filter capacitor(s) between these pins and PGND pins.

## ABSOLUTE MAXIMUM RATINGS

**CAUTION:** Absolute Maximum ratings are stress ratings only. Functional operation beyond the recommended operating conditions is not implied. Stress beyond the absolute maximum ratings may impair device life. Exposure to absolute maximum rated conditions for extended periods may affect device reliability.

### Absolute Maximum Pin Ratings

PARAMETER	SYMBOL	MIN	MAX	UNITS
PVIN, AVIN, VOUT		-0.3	7.0	V
EN, POK, SYNC		-0.3	$V_{IN}+0.3$	V
VFB, SS, RLLM, PGTE, VDDB		-0.3	2.5	V

### Absolute Maximum Thermal Ratings

PARAMETER	CONDITION	MIN	MAX	UNITS
Maximum Operating Junction Temperature			+150	°C
Storage Temperature Range		-65	+150	°C
Reflow Peak Body Temperature	(10 Sec) MSL3 JEDEC J-STD-020A		+260	°C

### Absolute Maximum ESD Ratings

PARAMETER	CONDITION	MIN	MAX	UNITS
HBM (Human Body Model)		±2000		V
CDM (Charged Device Model)		±500		V

## RECOMMENDED OPERATING CONDITIONS

PARAMETER	SYMBOL	MIN	MAX	UNITS
Input Voltage Range	$V_{IN}$	2.7	6.6	V
Output Voltage Range	$V_{OUT}$	0.75	$V_{IN} - V_{DO}^{(1)}$	V
Output Current Range	$I_{OUT}$		3	A
Operating Junction Temperature	$T_J$	-40	+125	°C

## THERMAL CHARACTERISTICS

PARAMETER	SYMBOL	TYPICAL	UNITS
Thermal Shutdown	$T_{SD}$	160	°C
Thermal Shutdown Hysteresis	$T_{SDH}$	25	°C
Thermal Resistance: Junction to Ambient (0 LFM) <sup>(2)</sup>	$\theta_{JA}$	30	°C/W
Thermal Resistance: Junction to Case (0 LFM)	$\theta_{JC}$	3	°C/W

(1)  $V_{DO}$  (dropout voltage) is defined as  $(I_{LOAD} \times \text{Dropout Resistance})$ . Please refer to Electrical Characteristics Table.

(2) Based on 2oz. external copper layers and proper thermal design in line with EIJ/JEDEC JESD51-7 standard for high thermal conductivity boards.

## ELECTRICAL CHARACTERISTICS

NOTE:  $V_{IN} = PVIN = AVIN = 5V$ , Minimum and Maximum values are over operating ambient temperature range unless otherwise noted. Typical values are at  $T_A = 25^\circ C$ .

PARAMETER	SYMBOL	TEST CONDITIONS	MIN	TYP	MAX	UNITS
Operating Input Voltage	$V_{IN}$	$PVIN = AVIN$	2.7		6.6	V
Under Voltage Lock-Out – $V_{IN}$ Rising	$V_{UVLOR}$	Voltage above which UVLO is not asserted	2	2.3	2.45	V
Under Voltage Lock-Out – $V_{IN}$ Falling	$V_{UVLOF}$	Voltage below which UVLO is asserted	1.7	2.1	2.3	V
Under Voltage Lock-Out Hysteresis	$V_{UVLO\_HYS}$			200		mV
Shut-Down Supply Current	$I_S$	$EN = 0V$		40	60	$\mu A$
AVIN Quiescent Current	$I_{AVINQ}$	LLM/SYNC = High $V_{OUT} = 0.75V$		650	900	$\mu A$
No Load Quiescent Current	$I_{VINQ}$	$PVIN$ and $AVIN$ $V_{OUT} = 1.2V$		40		mA
Feedback Pin Voltage <sup>(3)</sup>	$V_{FB}$	$V_{OUT} = 0.75V$ $I_{LOAD} = 0, T_A = 25^\circ C$	0.7425	0.75	0.7575	V
Feedback Pin Voltage (Load, Temp.)	$V_{FB}$	$0A \leq I_{LOAD} \leq 3A$ $-40^\circ C \leq T_J \leq 125^\circ C$	0.739	0.75	0.761	V
Feedback Pin Voltage (Line, Load, Temp.)	$V_{FB}$	$2.7V \leq V_{IN} \leq 6.6V$ $0A \leq I_{LOAD} \leq 3A$ $-40^\circ C \leq T_J \leq 125^\circ C$	0.735	0.75	0.765	V
Feedback pin Input Leakage Current <sup>(4)</sup>	$I_{FB}$	VFB pin input leakage current	-10		10	nA
$V_{OUT}$ Rise Time Range <sup>(4)</sup>	$t_{RISE}$	Capacitor programmable	0.8		8	ms
Soft Start Capacitance Range <sup>(4)</sup>	$C_{SS\_RANGE}$	Recommended $C_{SS}$ range	10		100	nF
Soft-Start Charging Current	$I_{SS}$		3.5	10	15	$\mu A$
Drop-Out Resistance <sup>(4)</sup>	$R_{DO}$	Input to output resistance		50	80	$m\Omega$
Drop-Out Voltage <sup>(4)</sup>	$V_{DO}$	$I_{OUT} = 3A$		150	240	mV

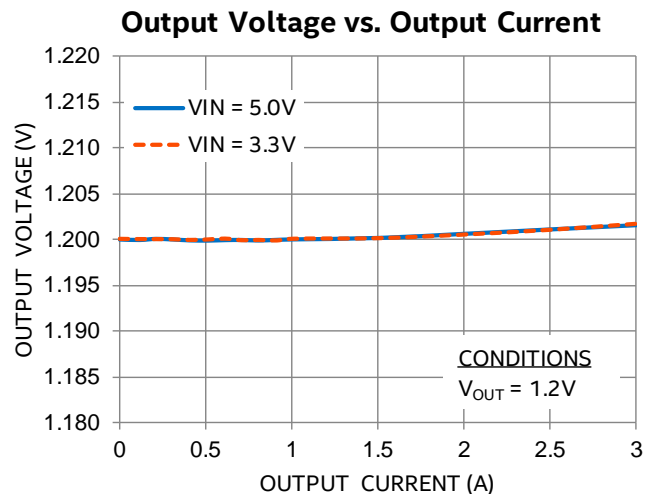
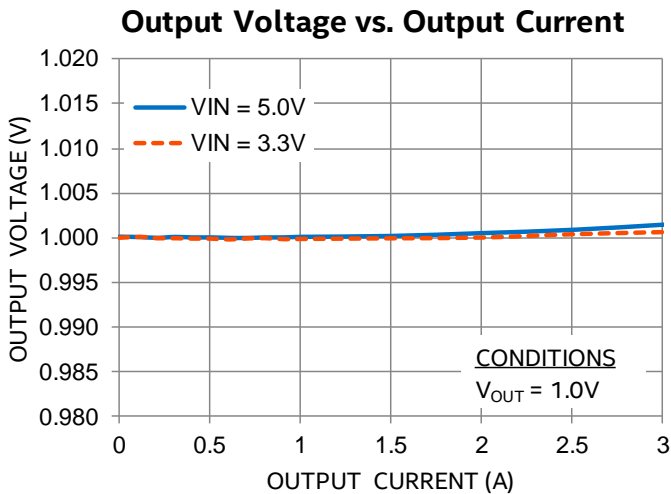
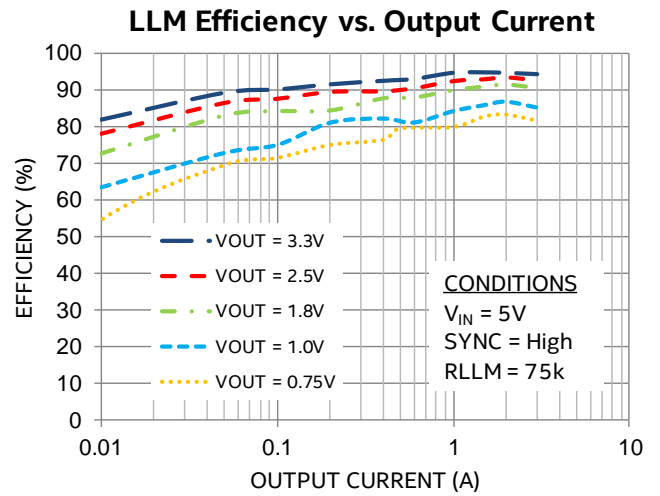
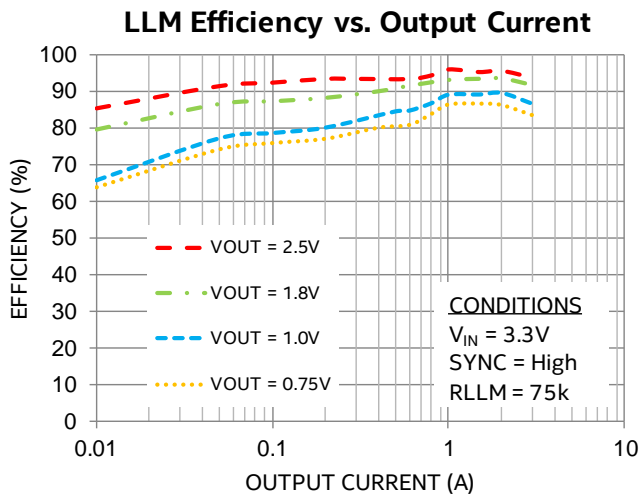
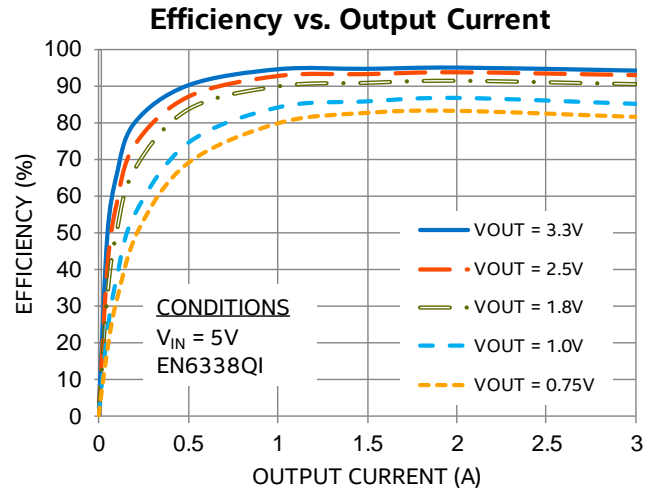
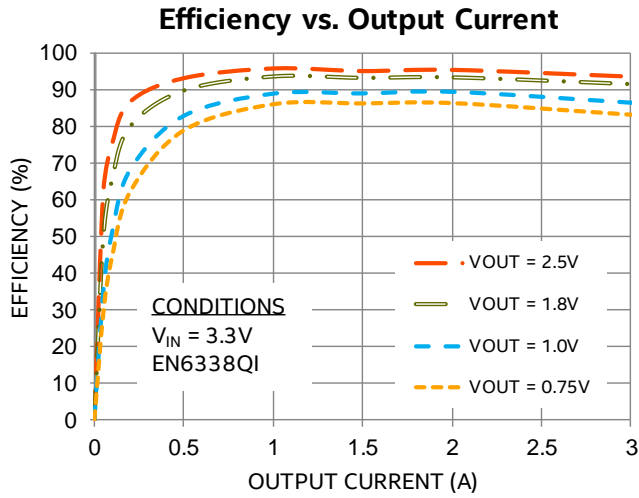
PARAMETER	SYMBOL	TEST CONDITIONS	MIN	TYP	MAX	UNITS
Continuous Output Current	$I_{OUT}$		0		3	A
Over Current Trip Level	$I_{OCP}$	$V_{IN} = 5V, V_{OUT} = 1.2V$	4	6.5		A
Disable Threshold	$V_{DISABLE}$	EN pin logic going low	1.2	1.34	1.48	V
EN Threshold	$V_{EN}$	EN pin logic going high	1.22	1.36	1.5	V
EN Pin Input Current	$I_{EN}$	$V_{EN} = 5V$ ; EN pin has $\sim 250k\Omega$ pull down		20	35	$\mu A$
EN Pull-Down Resistance	$R_{EN\_DOWN}$	$V_{EN} = 5V$ ; Not a passive resistance		250		k $\Omega$
Switching Frequency	$F_{SW}$	Free running clock frequency	1.6	1.9	2.2	MHz
SYNC Input Threshold – Low	$V_{SYNC\_LO}$	SYNC Clock Logic Level			0.8	V
SYNC Input Threshold – High <sup>(5)</sup>	$V_{SYNC\_HI}$	SYNC Clock Logic Level	1.8		2.5	V
POK High Threshold	$POK_{HI}$	Percentage of $V_{OUT}$ nominal when POK is asserted high		90		%
POK Low Voltage	$V_{POKL}$	4mA sink into POK			0.4	V
POK High Voltage	$V_{POKH}$	$2.7V \leq V_{IN} \leq 6.6V$			$V_{IN}$	V
POK Pin Leakage Current <sup>(4)</sup>	$I_{POKH}$	POK is high			1	$\mu A$
LLM Headroom <sup>(4)</sup>		Minimum $V_{IN} - V_{OUT}$		800		mV
LLM Logic Low (LLM/SYNC PIN)	$V_{LLM\_LO}$	LLM Static Logic Level			0.3	V
LLM Logic High (LLM/SYNC PIN)	$V_{LLM\_HI}$	LLM Static Logic Level	1.5			V
LLM/SYNC Pin Current		LLM/SYNC Pin is $< 2.5V$		$< 100$		nA

(3) The VFB pin is a sensitive node. Do not touch VFB while the device is in regulation.

(4) Parameter not production tested but is guaranteed by design.

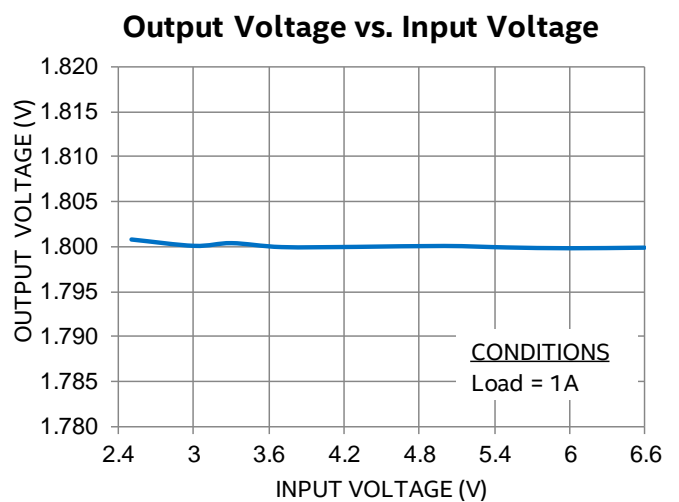
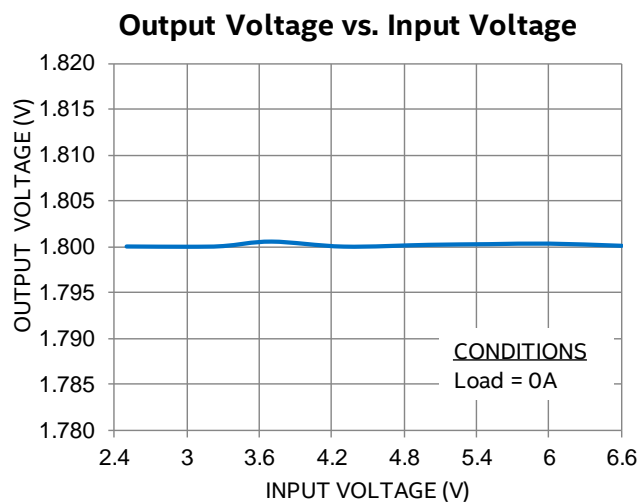
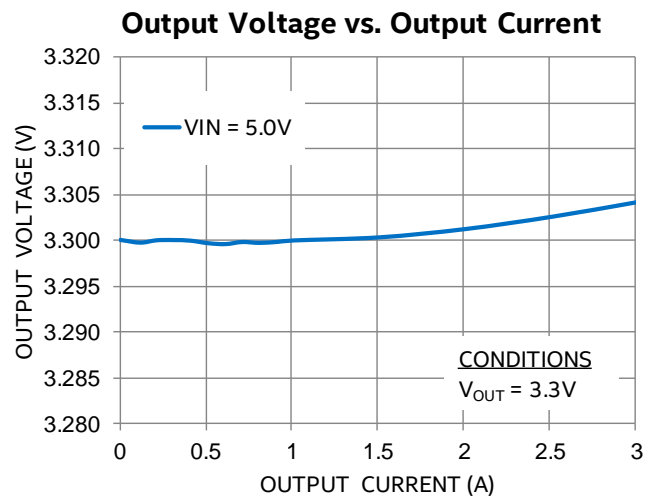
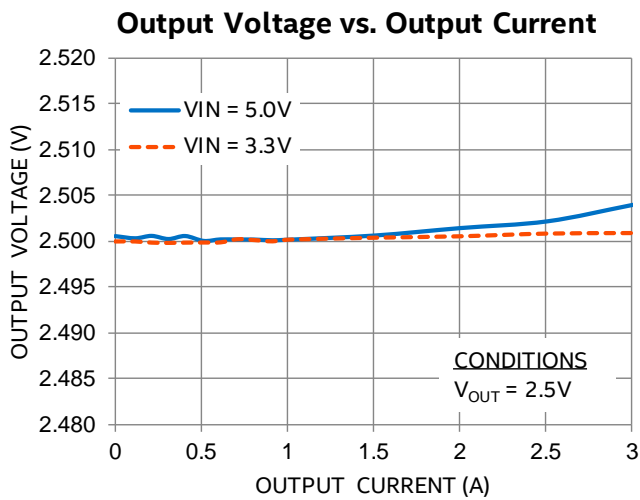
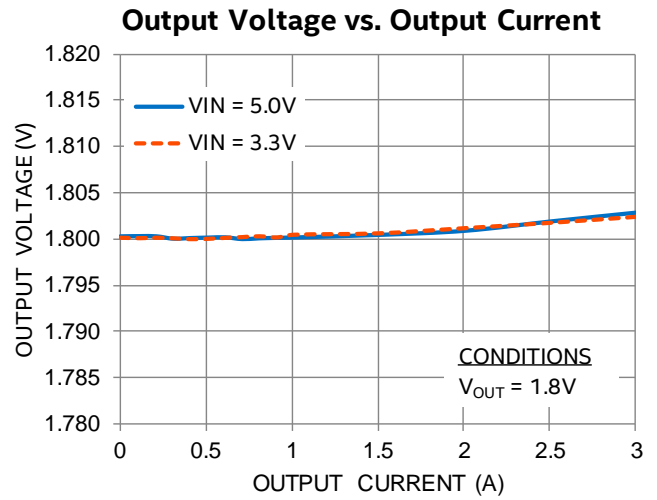
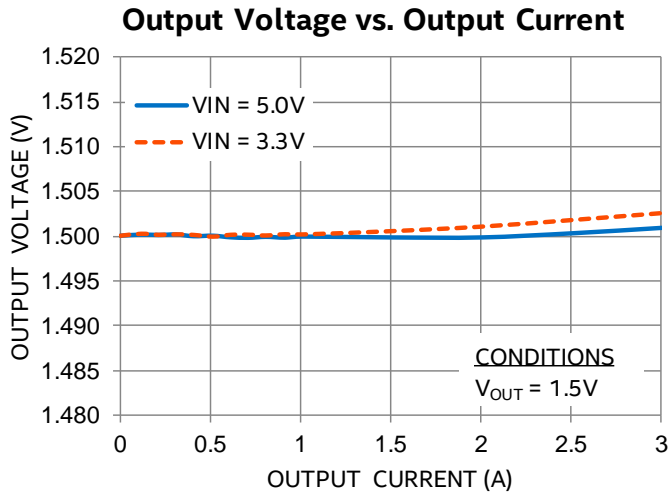
(5) High logic for frequency synchronization with SYNC pin must be below 2.5V.

## TYPICAL PERFORMANCE CURVES



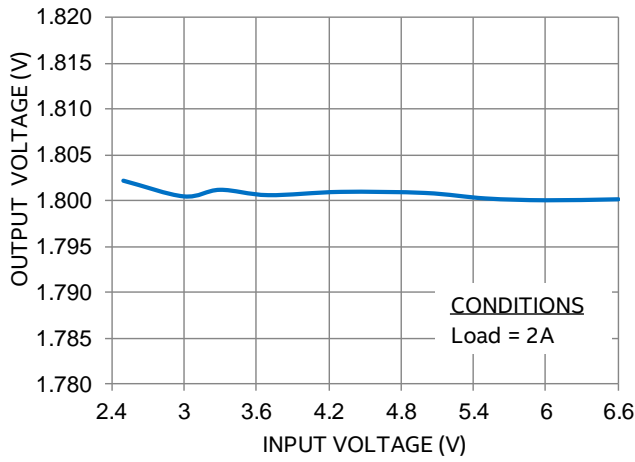


## TYPICAL PERFORMANCE CURVES (CONTINUED)

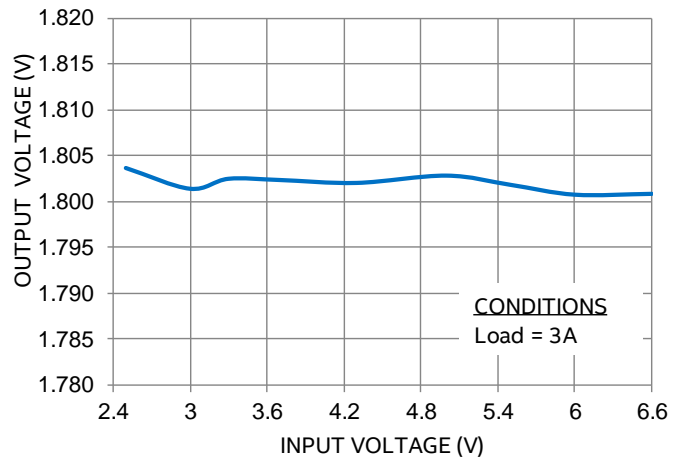


## TYPICAL PERFORMANCE CURVES (CONTINUED)

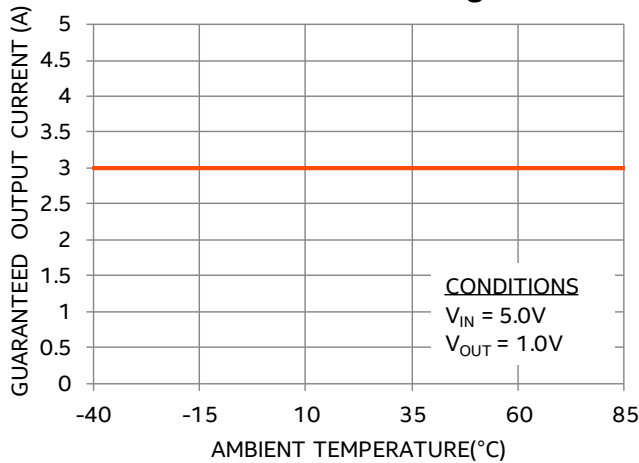
**Output Voltage vs. Input Voltage**



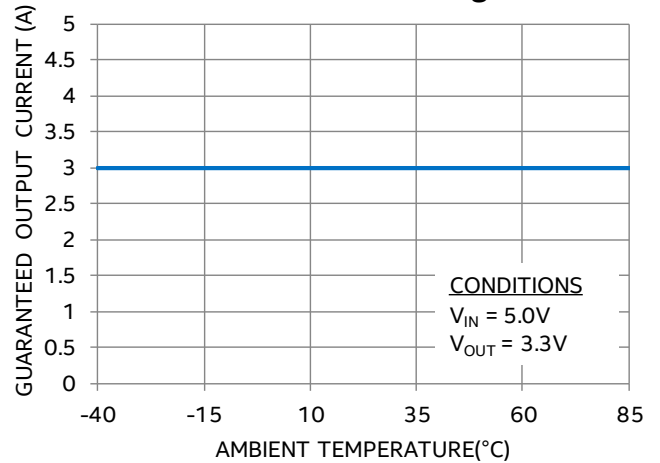
**Output Voltage vs. Input Voltage**



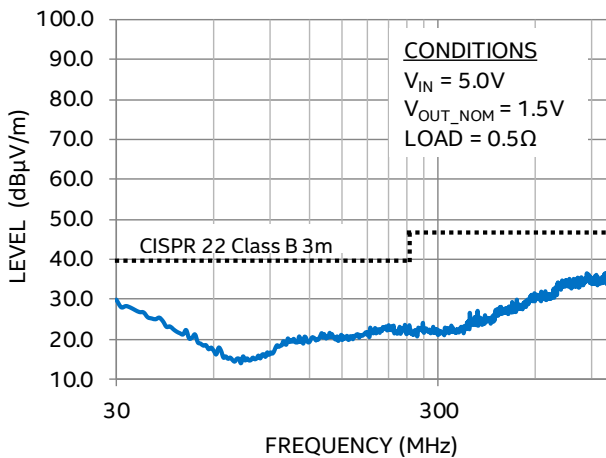
**No Thermal Derating**



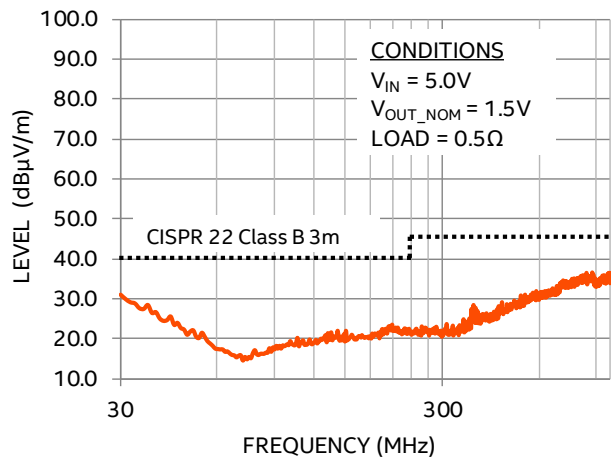
**No Thermal Derating**



**EMI Performance (Horizontal Scan)**

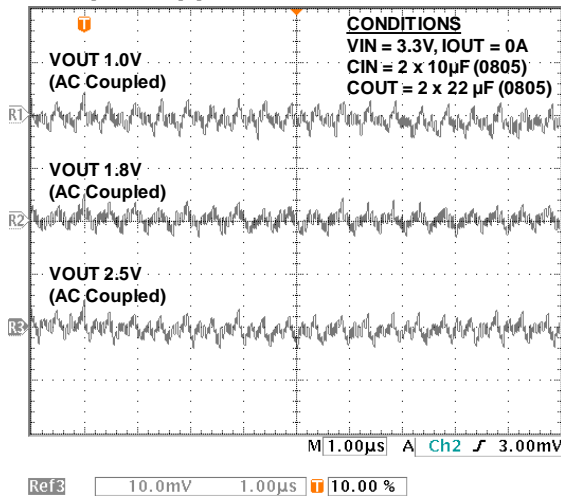


**EMI Performance (Vertical Scan)**

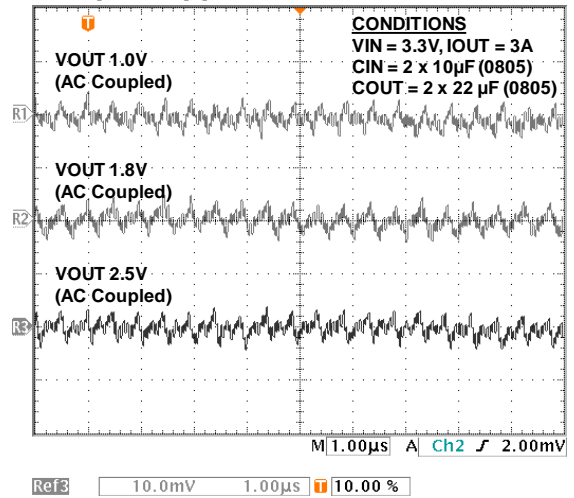


## TYPICAL PERFORMANCE CHARACTERISTICS

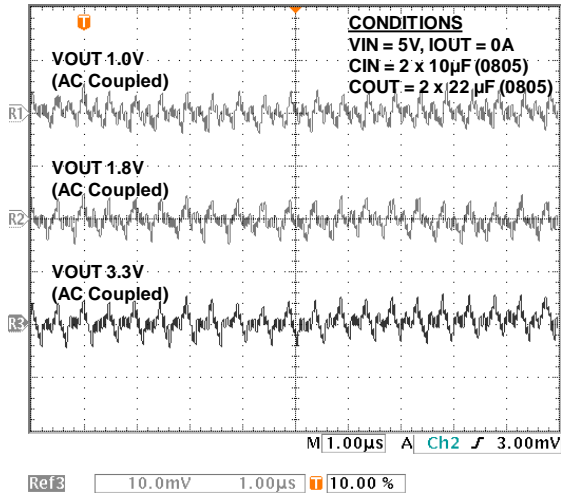
Output Ripple at 20MHz Bandwidth



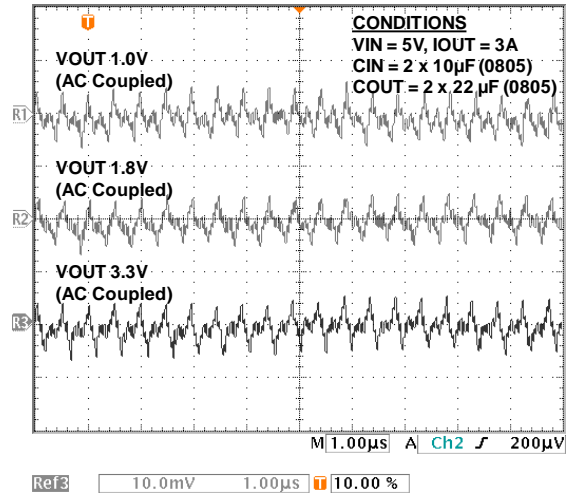
Output Ripple at 20MHz Bandwidth



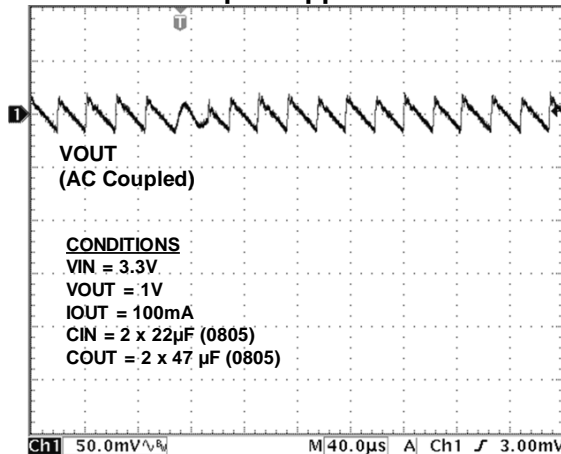
Output Ripple at 20MHz Bandwidth



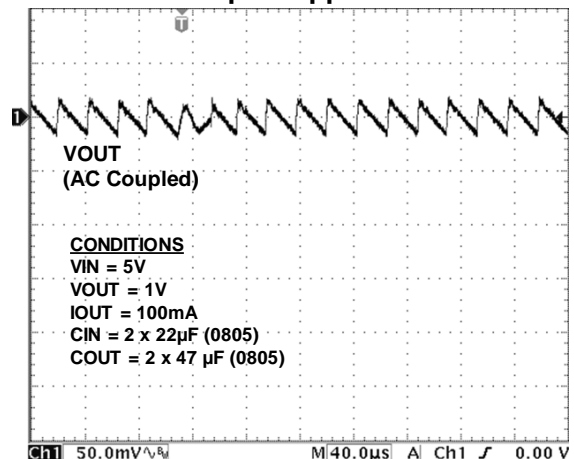
Output Ripple at 20MHz Bandwidth



LLM Output Ripple at 100mA

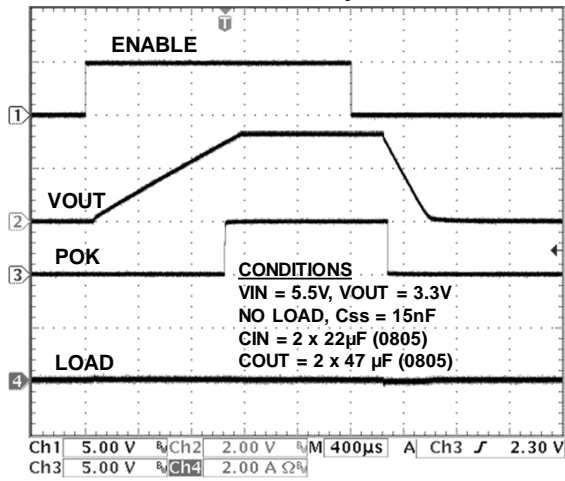


LLM Output Ripple at 100mA

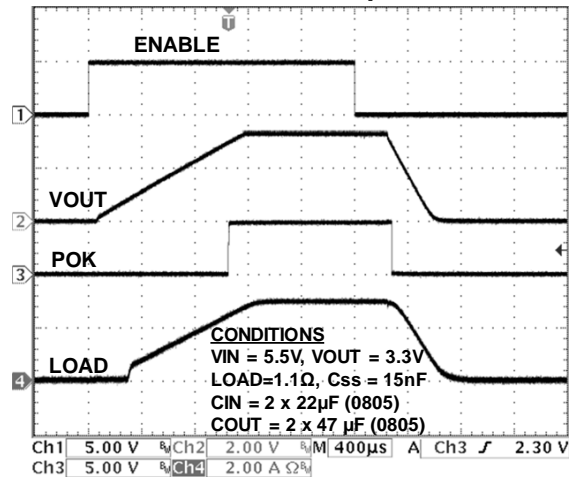


## TYPICAL PERFORMANCE CHARACTERISTICS (CONTINUED)

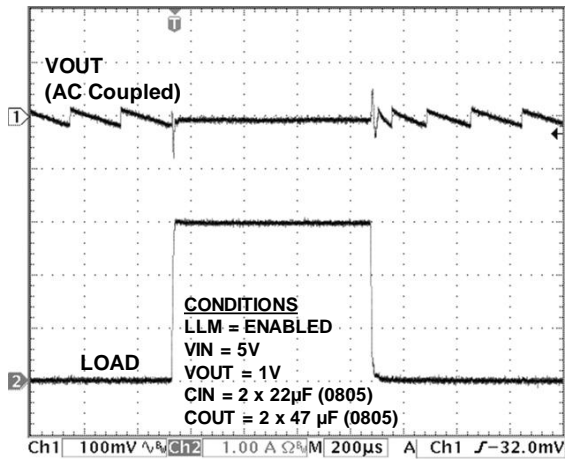
Enable Power Up/Down



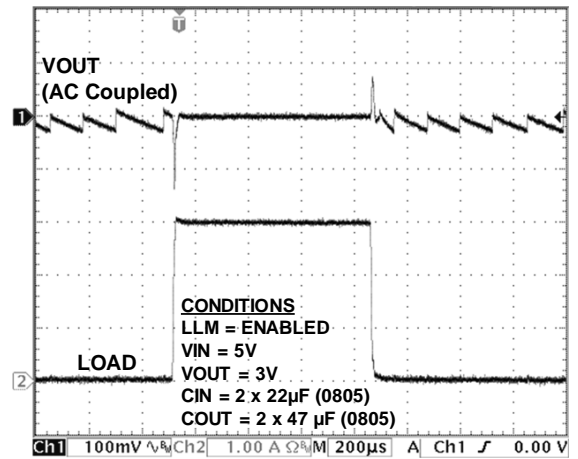
Enable Power Up/Down



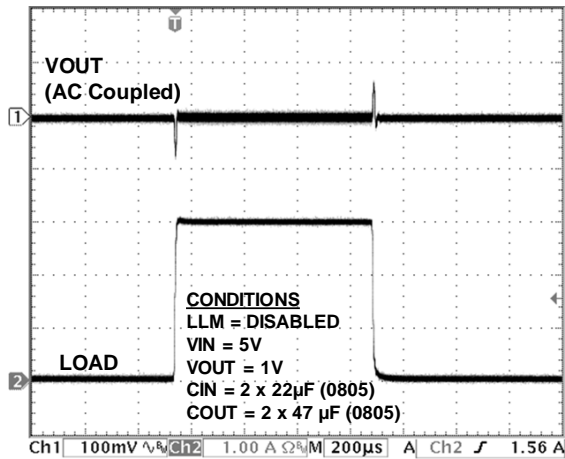
LLM Load Transient from 0.01 to 3A



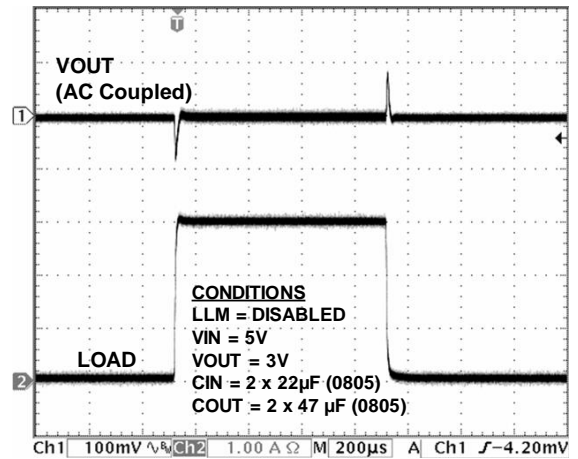
LLM Load Transient from 0.01 to 3A



PWM Load Transient from 0 to 3A



PWM Load Transient from 0 to 3A



## FUNCTIONAL BLOCK DIAGRAM

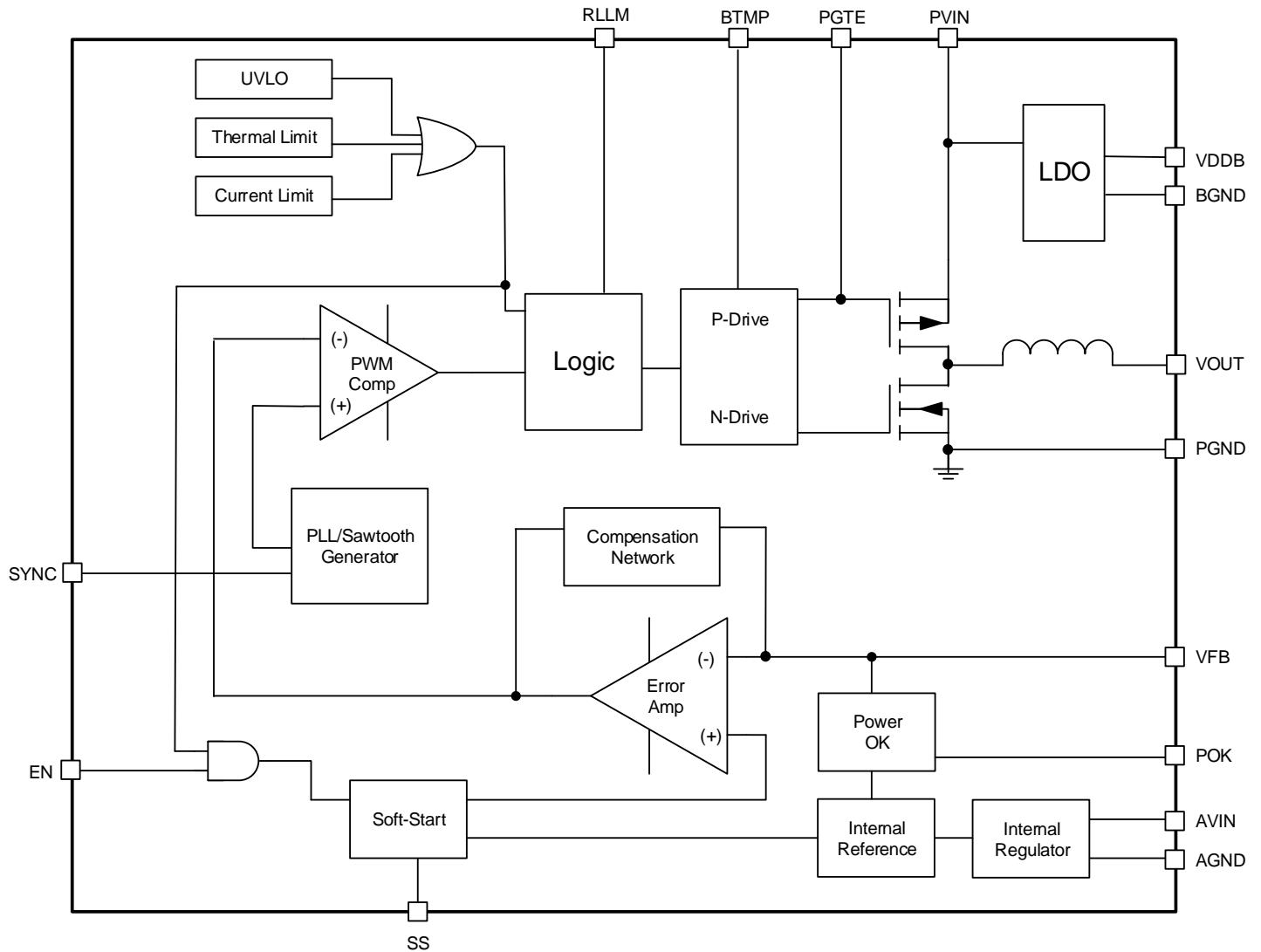


Figure 4: Functional Block Diagram

## FUNCTIONAL DESCRIPTION

### Synchronous DC-DC Step-Down PowerSoC

The EN6338QI is a synchronous DC-DC buck regulator with integrated internal MOSFETs. The nominal input voltage range is 2.7V to 6.6V. The output voltage is programmed using an external resistor divider network. The control loop is voltage-mode with a type III compensation network. Much of the compensation circuitry is internal to the device, but a phase-lead capacitor and resistor are required to complete the compensation network. The type III voltage mode architecture with integrated compensation maximizes loop bandwidth without increasing complexity. This architecture is designed to maintain stability with excellent gain and phase margin and improve transient response. The enhanced voltage mode architecture also provides high noise immunity at light load and maintains excellent line and load regulation. Up to 3A of continuous output current

can be drawn from this converter. The 1.9MHz switching frequency allows the use of smaller case size input and output capacitors within a small footprint.

The EN6338QI architecture includes the following features.

Operational Features:

- Automatic Light Load Mode (LLM) or Forced PWM mode selection
- Soft-start circuit allowing controlled startup and shutdown
- Power OK circuit indicating the output voltage is greater than 90% of programmed value

Protection Features:

- Over-current protection from short circuit or excessive load current
- Thermal shutdown with hysteresis to prevent over temperature stress
- Under-voltage lockout protection to prevent under-voltage operation

### Light Load Mode (LLM) Operation

The EN6338QI uses a proprietary Light Load Mode (LLM) to provide high efficiency at low output currents. When the LLM/SYNC pin is asserted high, the device is in automatic LLM “Detection” mode. When the LLM/SYNC pin is low, the device is forced into PWM mode. In automatic LLM “Detection” mode, when a low output current condition is detected, the device will:

- (1) Step  $V_{OUT}$  up by approximately 1.0% above the nominal operating output voltage setting,  $V_{NOM}$  and as low as -0.5% below  $V_{NOM}$ , and then
- (2) Shut down unnecessary circuitry, and then
- (3) Monitor  $V_{OUT}$

When  $V_{OUT}$  falls below  $V_{NOM}$ , the device will repeat (1), (2), and (3). The voltage step-up, or pre-positioning, improves transient droop when a load transient causes a transition from LLM mode to PWM mode. If a load transient occurs, causing  $V_{OUT}$  to fall below the threshold  $V_{MIN}$ , the device will exit LLM operation and begin normal PWM operation. Figure 5 demonstrates  $V_{OUT}$  behavior during the transition into and out of LLM operation.

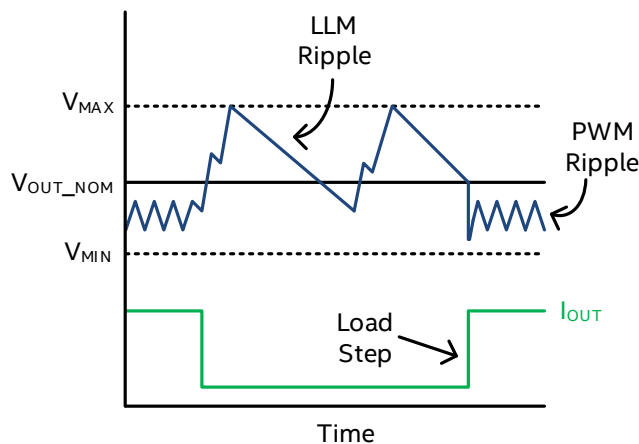


Figure 5: Light Load Mode Operation Illustration

Many multi-mode DCDC converters suffer from a condition that occurs when the load current increases only slowly so that there is no load transient driving  $V_{OUT}$  below the  $V_{MIN}$  threshold. In this condition, the device would never exit LLM operation. This could adversely affect efficiency and cause unwanted ripple. To prevent this from occurring, the EN6338QI periodically exits LLM mode into PWM mode and measures the load current. If the load current is above the LLM threshold current, the device will remain in PWM mode. If the load current is below the LLM threshold, the device will re-enter LLM operation. There may be a small overshoot or undershoot in  $V_{OUT}$  when the device exits and re-enters LLM. The load current at which the device will enter LLM mode is a function of input and output voltage, and the RLLM pin resistor. For PWM only operation, the RLLM pin can be left open. There is a minimum headroom between input and output of 800mV in order to engage into LLM mode.

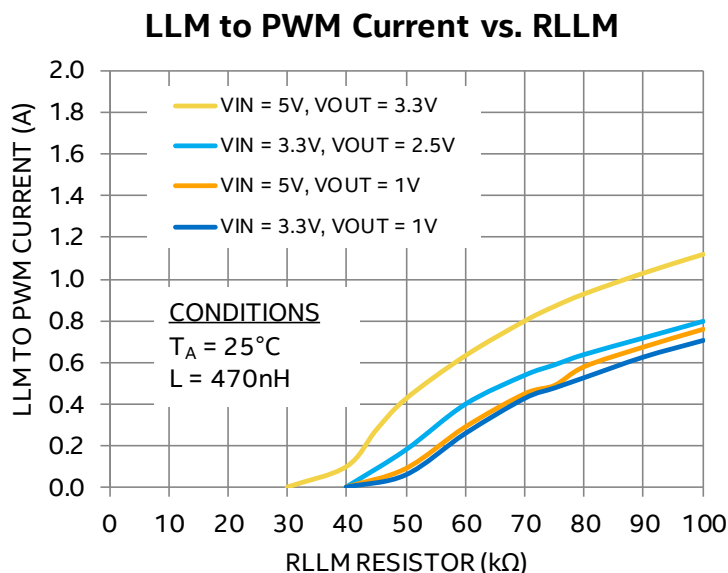


Figure 6: LLM to PWM Transition Point with Various RLLM Values

## Enable Operation

The enable (EN) pin provides a mean to startup or to shutdown the device. When the EN pin is asserted high, the device will undergo a normal soft-start where the output will rise monotonically into regulation. Asserting a logic low on this pin will deactivate the device by initiating a soft-shutdown. The soft-shutdown time is approximately 5 times faster than the soft-start time. The EN pin is internally pulled low by a non-passive resistance of 250kΩ.

## Soft-Start Operation

The soft-start circuitry will reduce inrush current during startup as the regulator charges the output voltage up to nominal level gradually. The output rise time is controlled by the soft-start capacitor, which is placed between the SS pin and the AGND pin. When the part is enabled, the soft-start (SS) current generator charges the SS capacitor in a linear manner. Once the voltage on the SS capacitor reaches 0.75V, the controller selects the internal bandgap voltage as the reference. The voltage across the SS capacitor will continue ramping up until it reaches around 1.36V. The rise time is defined as the time needed by the output voltage to go from zero to the programmed value. The rise time ( $t_{RISE}$ ) is given by the following equation:

$$t_{\text{RISE}} [\text{ms}] = C_{\text{SS}} [\text{nF}] \times 0.08$$

With a 15nF soft-start capacitance on the SS pin, the soft-start rise time will be set to 1.2ms. The recommended range for the value of the SS capacitor is between 10nF and 100nF. Note that excessive bulk capacitance on the output can cause an over current event on startup if the soft-start time is too low. Refer to the Compensation and Transient Response section for details on proper bulk capacitance usage.

## POK Operation

The Power OK (POK) is an open drain signal to indicate if the output voltage is within the specified range. POK is asserted high when the rising output voltage exceeds 90% of the programmed output voltage. An external resistor (10k) should be connected to the input in order to pull POK high. If the nominal output voltage falls below 90%, the POK signal will be asserted low by an internal 4mA pull-down transistor.

## Over-Current Protection (OCP)

The current limit function is achieved by sensing the peak current flowing through the topside power PFET. When the sensed current exceeds the over current trip point (see Electrical Characteristics Table), both power FETs are turned off for the remainder of the switching cycle. If the over-current condition is removed, the over-current protection circuit will enable normal PWM operation. If the over-current condition persists, the soft start capacitor will gradually discharge causing the output voltage to fall. When the OCP fault is removed, the output voltage will ramp back up to the desired voltage. This cycle can continue indefinitely as long as the over current condition persists. The OCP circuit will disable operation and protect the device from excessive current during operation without compromising the full load capability of the device.

## Thermal Protection

The thermal shutdown circuit disables the device operation (switching stops) when the junction temperature exceeds 160°C. When the junction temperature drops by approximately 25°C, the converter will re-start with a normal soft-start. By preventing operation at excessive temperatures, the thermal shutdown circuit will protect the device from overstress.

## Input Under-Voltage Lock-Out (UVLO)

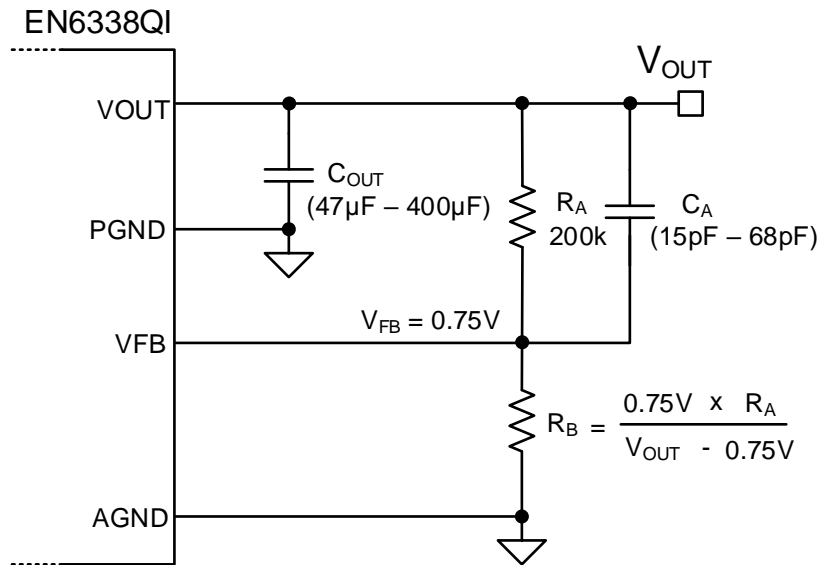
When the device input voltage falls below UVLO, switching is disabled to prevent operation at insufficient voltage levels. During startup, the UVLO circuit ensures that the converter will not start switching until the input voltage is above the specified minimum voltage. Hysteresis and input de-glitch circuits are incorporated in order to ensure high noise immunity and prevent a false trigger in the UVLO voltage region.



## APPLICATION INFORMATION

### Output Voltage Setting

The EN6338QI output voltage is programmed using a simple resistor divider network ( $R_A$  and  $R_B$ ). Figure 7 shows the resistor divider configuration.



**Figure 7:  $V_{OUT}$  Resistor Divider & Compensation Capacitor**

The recommended  $R_A$  resistor value is 200kΩ and the feedback voltage is typically 0.75V. Depending on the output voltage ( $V_{OUT}$ ), the  $R_B$  resistor value may be calculated as shown in Figure 7. Since the accuracy of the output voltage setting is dependent upon the feedback voltage and the external resistors, 1% or better resistors are recommended. The external compensation capacitor ( $C_A$ ) is also required in parallel with  $R_A$ . Depending on input and output voltage, the recommended external compensation values are shown in Table 1.

**Table 1: External Compensation Recommendations**

$V_{IN}$	$V_{OUT}$	$R_B$	$C_A$	$R_A$	$C_{OUT}$ (0805)
2.7V – 6.6V	0.75V	OPEN	27pF	200kΩ	2 x 22µF
	0.9V	1MΩ	27pF		
	1.0V	604kΩ	22pF		
	1.2V	332kΩ	22pF		
	1.5V	200kΩ	18pF		
	1.8V	143kΩ	18pF		
	2.5V	84.5kΩ	15pF		
	3.3V	59kΩ	15pF		

## Compensation and Transient Response

The EN6338QI uses an enhanced type III voltage mode control architecture. Most of the compensation is internal, which simplifies the design. In some applications, improved transient performance may be desired with additional output capacitors ( $C_{OUT}$ ). In such an instance, the phase-lead capacitor ( $C_A$ ) can be adjusted depending on the total output capacitance. Using Table 1 as the reference for  $C_A$ , if  $C_{OUT}$  is increased, then the  $C_A$  should also be increased. The relationship is linearly shown below:

$$\Delta C_{OUT} \approx +100\mu\text{F} \rightarrow \Delta C_A \approx +10\text{pF}$$

As  $C_{OUT}$  increases and the  $C_A$  value is adjusted, the device bandwidth will reach its optimization level (at around  $1/10^{\text{th}}$  of the switching frequency). As shown in Table 1, the recommended  $C_A$  value is lower for the 5V input than 3.3V input. This is to ensure that the loop bandwidth is not over extended due to the increased gain at the higher input voltage range. The  $C_A$  value may be extrapolated for other input voltages. The limitation for adjusting the compensation is based on diminished return. Further adjustments by increasing  $C_{OUT}$  and increasing  $C_A$  may not yield better transient response or in some situations cause lower gain and phase margin. Over compensating with excessive output capacitance may also cause the device to trigger current limit on startup due to the energy required to charge the output up to regulation level. Due to such limitations, the recommended maximum output capacitance ( $C_{OUT\_MAX}$ ) is  $400\mu\text{F}$  and the recommended maximum phase-lead capacitance ( $C_{A\_MAX}$ ) is  $68\text{pF}$ . Note that lower output voltages can accommodate a higher  $C_A$  value.

## Input Capacitor Selection

The input of synchronous buck regulators can be very noisy and should be decoupled properly in order to ensure stable operation. In addition, input parasitic line inductance can attribute to higher input voltage ripple. The EN6338QI requires a minimum of  $2 \times 10\mu\text{F}$  0805 or  $1 \times 22\mu\text{F}$  1206 size with sufficient voltage rating. As the distance of the input power source to the input of the EN6338QI is increased, it is recommended to increase input capacitance in order to mitigate the line inductance from the source. Low-ESR ceramic capacitors should be used. The dielectric must be X5R or X7R rated and the size must be at least 0805 (EIA) due to derating. Y5V or equivalent dielectric formulations must not be used as these lose too much capacitance with frequency, temperature and bias voltage. In some applications, lower value capacitors are needed in parallel with the larger capacitors in order to provide high frequency decoupling. Larger electrolytic or tantalum bulk capacitors may be used in conjunction to increase total input capacitance but should not be used solely as a replacement for the ceramic capacitors.

**Table 3: Recommended Minimum Input Capacitors**

DESCRIPTION	MFG	P/N
10 $\mu\text{F}$ $\pm 20\%$ , 10V X5R, 0805	Taiyo Yuden	LMK212BJ106KG-T
	Murata	GRM21BR61A106KE19L
	TDK	C2012X5R1A106M125AB
22 $\mu\text{F}$ $\pm 20\%$ , 10V X5R, 1206	Taiyo Yuden	LMK316BJ226ML-T
	Murata	GRM31CR61A226ME19L

## Output Capacitor Selection

The output ripple of a synchronous buck converter can be attributed to its inductance, switching frequency and output decoupling. The EN6338QI requires a minimum of 2 x 22µF 0805 output capacitors or 1 x 47µF 1206 size. Low ESR ceramic capacitors should be used. The dielectric must be X5R or X7R rated and the size must be at least 0805 (EIA) due to derating. Y5V or equivalent dielectric formulations must not be used as these lose too much capacitance with frequency, temperature and bias voltage.

**Table 4: Recommended Output Capacitors**

DESCRIPTION	MFG	P/N
22µF ±20%, 10V X5R, 0805	Taiyo Yuden	LMK212BBJ226MG-T
	Murata	GRM21BR61A226ME51
	TDK	C2012X5R1A226M125AB
47µF ±20%, 10V X5R, 1206	Taiyo Yuden	JMK316BJ476ML-T
	Murata	GRM31CR60J476ME19L
	TDK	C3216X5R1A476M160AB

Output ripple voltage is determined by the aggregate output capacitor impedance. Output impedance, denoted as Z, is comprised of effective series resistance (ESR) and effective series inductance (ESL):

$$Z = ESR + ESL$$

The resonant frequency of a ceramic capacitor is inversely proportional to the capacitance. Lower capacitance corresponds to higher resonant frequency. When two capacitors are placed in parallel, the benefit of both are combined. It is beneficial to decouple the output with capacitors of various capacitance and size. Placing them all in parallel reduces the impedance and will hence result in lower output ripple.

$$\frac{1}{Z_{Total}} = \frac{1}{Z_1} + \frac{1}{Z_2} + \dots + \frac{1}{Z_n}$$

## THERMAL CONSIDERATIONS

Thermal considerations are important elements of power supply design. Whenever there are power losses in a system, the heat that is generated by the power dissipation needs to be taken into account. The Intel Enpirion PowerSoC technology helps alleviate some of those concerns.

The EN6338QI DC-DC converter is packaged in a 3.75mm x 3.75mm x 1.9mm 19-pin LGA package. The LGA package is constructed with copper lead frames that have exposed thermal pads. The exposed thermal pad on the package should be soldered directly on to a copper ground pad on the printed circuit board (PCB) to act as a heat sink. The recommended maximum junction temperature for continuous operation is 125°C. Continuous operation above 125°C may reduce long-term reliability. The device has a thermal overload protection circuit designed to turn off the device at an approximate junction temperature value of 160°C.

The following example and calculations illustrate the thermal performance of the EN6338QI with the following parameters:

$$V_{IN} = 5V$$

$$V_{OUT} = 3.3V$$

$$I_{OUT} = 3A$$

First, calculate the output power.

$$P_{OUT} = V_{OUT} \times I_{OUT} = 3.3V \times 3A = 9.9W$$

Next, determine the input power based on the efficiency ( $\eta$ ) shown in Figure 8.

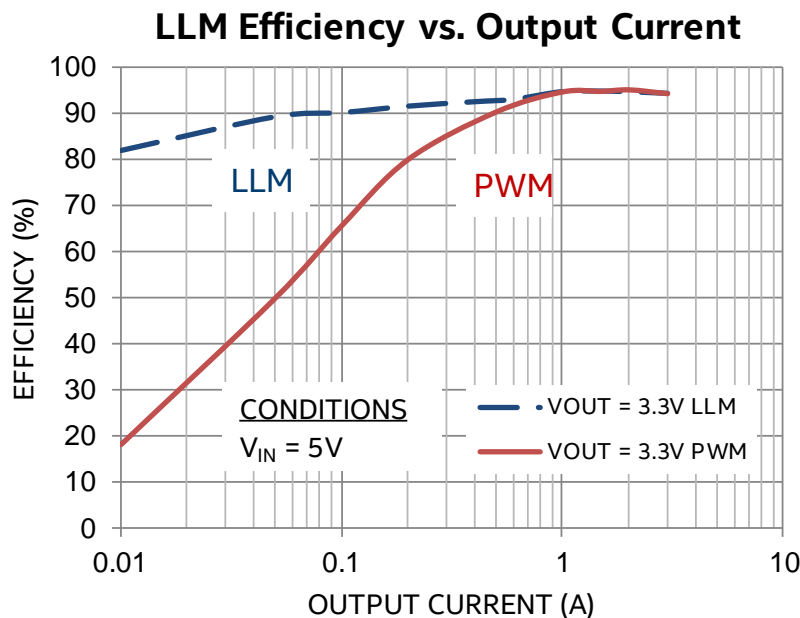


Figure 8: Efficiency vs. Output Current

For  $V_{IN} = 5V$ ,  $V_{OUT} = 3.3V$  at  $3A$ ,  $\eta \approx 94.3\%$

$$\eta = P_{OUT} / P_{IN} = 94.3\% = 0.943$$

$$P_{IN} = P_{OUT} / \eta$$

$$P_{IN} \approx 9.9W / 0.943 \approx 10.5W$$

The power dissipation ( $P_D$ ) is the power loss in the system and can be calculated by subtracting the output power from the input power.

$$\begin{aligned} P_D &= P_{IN} - P_{OUT} \\ &= 10.5W - 9.9W \approx 0.6W \end{aligned}$$

With the power dissipation known, the temperature rise in the device may be estimated based on the theta JA value ( $\theta_{JA}$ ). The  $\theta_{JA}$  parameter estimates how much the temperature will rise in the device for every watt of power dissipation. The EN6338QI has a  $\theta_{JA}$  value of 30°C/W without airflow.

Determine the change in temperature ( $\Delta T$ ) based on  $P_D$  and  $\theta_{JA}$ .

$$\begin{aligned} \Delta T &= P_D \times \theta_{JA} \\ \Delta T &\approx 0.6W \times 30^\circ C/W \approx 18^\circ C \end{aligned}$$

The junction temperature ( $T_J$ ) of the device is approximately the ambient temperature ( $T_A$ ) plus the change in temperature. We assume the initial ambient temperature to be 25°C.

$$\begin{aligned} T_J &= T_A + \Delta T \\ T_J &\approx 25^\circ C + 18^\circ C \approx 43^\circ C \end{aligned}$$

The maximum operating junction temperature ( $T_{JMAX}$ ) of the device is 125°C, so the device can operate at a higher ambient temperature. The maximum ambient temperature ( $T_{AMAX}$ ) allowed can be calculated.

$$\begin{aligned} T_{AMAX} &= T_{JMAX} - P_D \times \theta_{JA} \\ &\approx 125^\circ C - 18^\circ C \approx 107^\circ C \end{aligned}$$

The maximum ambient temperature the device can reach is 107°C given the input and output conditions. Note that the efficiency will be slightly lower at higher temperatures and this calculation is an estimate.

## APPLICATION CIRCUITS

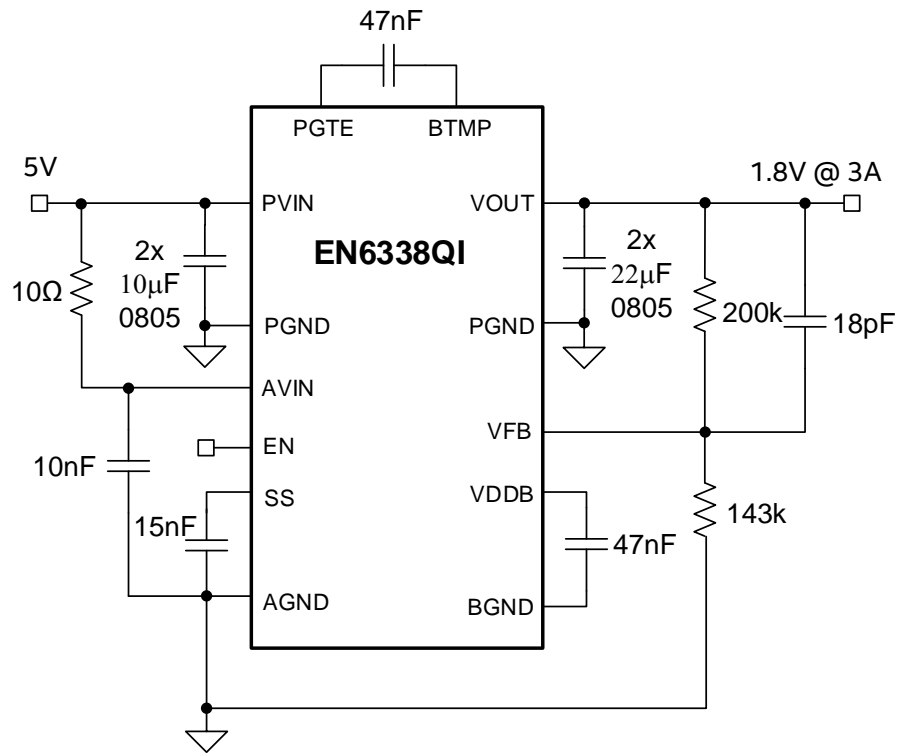


Figure 9: Smallest Solution Size Application Circuit for  $V_{OUT} = 1.8V$

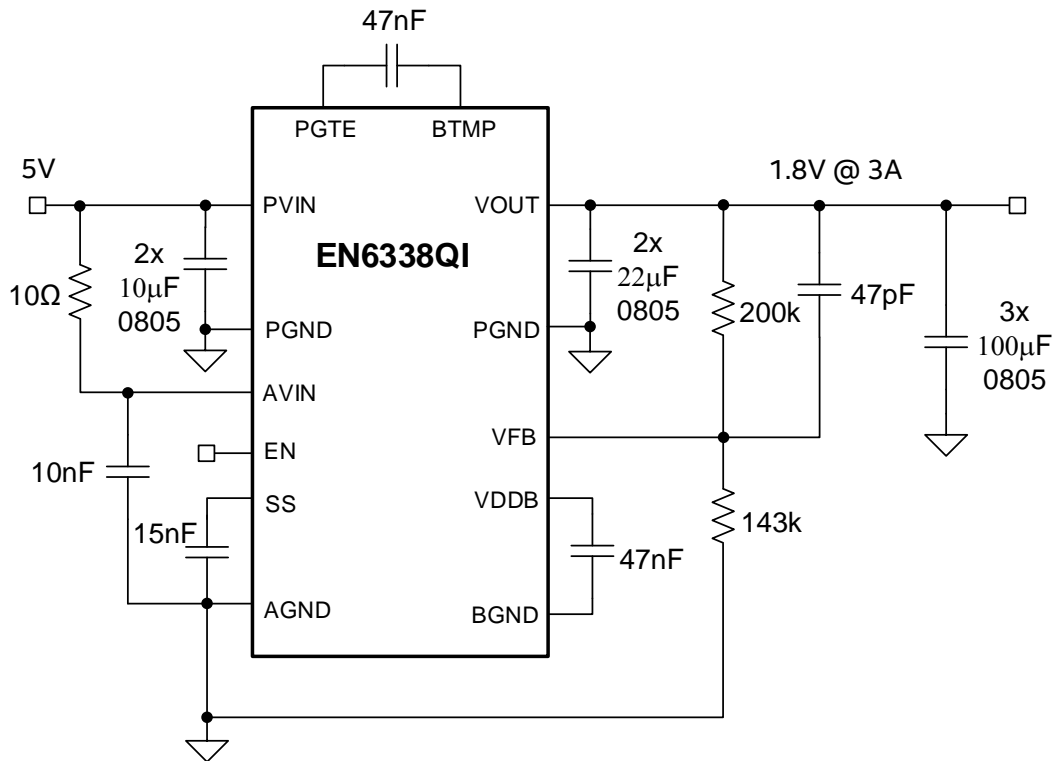


Figure 10: Improved Transient Response Application Circuit for  $V_{OUT} = 1.8V$

## LAYOUT RECOMMENDATIONS

Figure 11 shows critical components and layer 1 traces of a recommended minimum footprint EN6338QI layout. EN and other small signal pins need to be connected and routed according to specific customer application. Visit the Enpirion Power Solutions website at [www.intel.com/enpirion](http://www.intel.com/enpirion) for more information regarding layout. Please refer to this Figure 11 while reading the layout recommendations in this section.

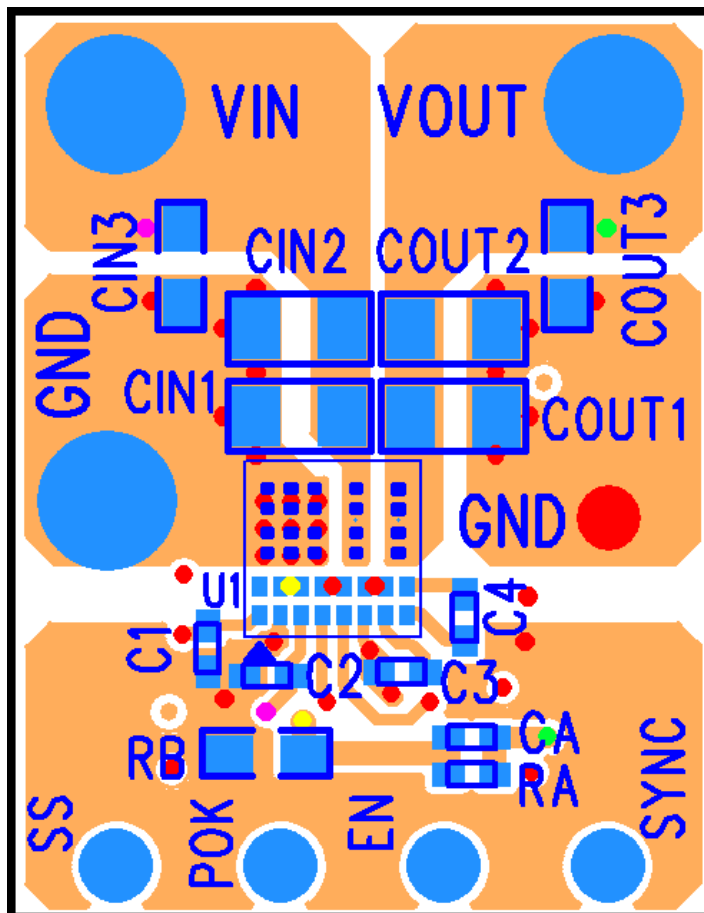


Figure 11: Top PCB Layer Critical Components and Copper for Minimum Footprint (Top View)

**Recommendation 1:** The input and output filter capacitors should be placed on the same side of the PCB, and as close to the EN6338QI package as possible. The filter capacitors should be connected to the device with very short and wide traces. Do not use thermal reliefs or spokes when connecting the capacitor pads to the respective nodes. The Voltage and GND traces between the capacitors and the EN6338QI should be as close to each other as possible so that the gap between the two nodes is minimized, even under the capacitors.

**Recommendation 2:** The system ground plane should be on the 2<sup>nd</sup> layer (below the surface layer). This ground plane should be continuous and un-interrupted.

**Recommendation 3:** The ground thermal pad underneath the device must be connected to the system ground plane through as many vias as possible. The drill diameter of the vias should be 0.33mm, and the vias must have at least 1-oz. copper plating on the inside wall, making the finished hole size around 0.2mm to 0.26mm. Do not use thermal reliefs or spokes to connect the vias to the ground plane. This connection provides the path for heat dissipation from the converter. Please see Figure 11.

**Recommendation 4:** Multiple small vias (the same size as the thermal via discussed in recommendation 4) should be used to connect ground terminal of the input capacitor and output capacitors to the system ground

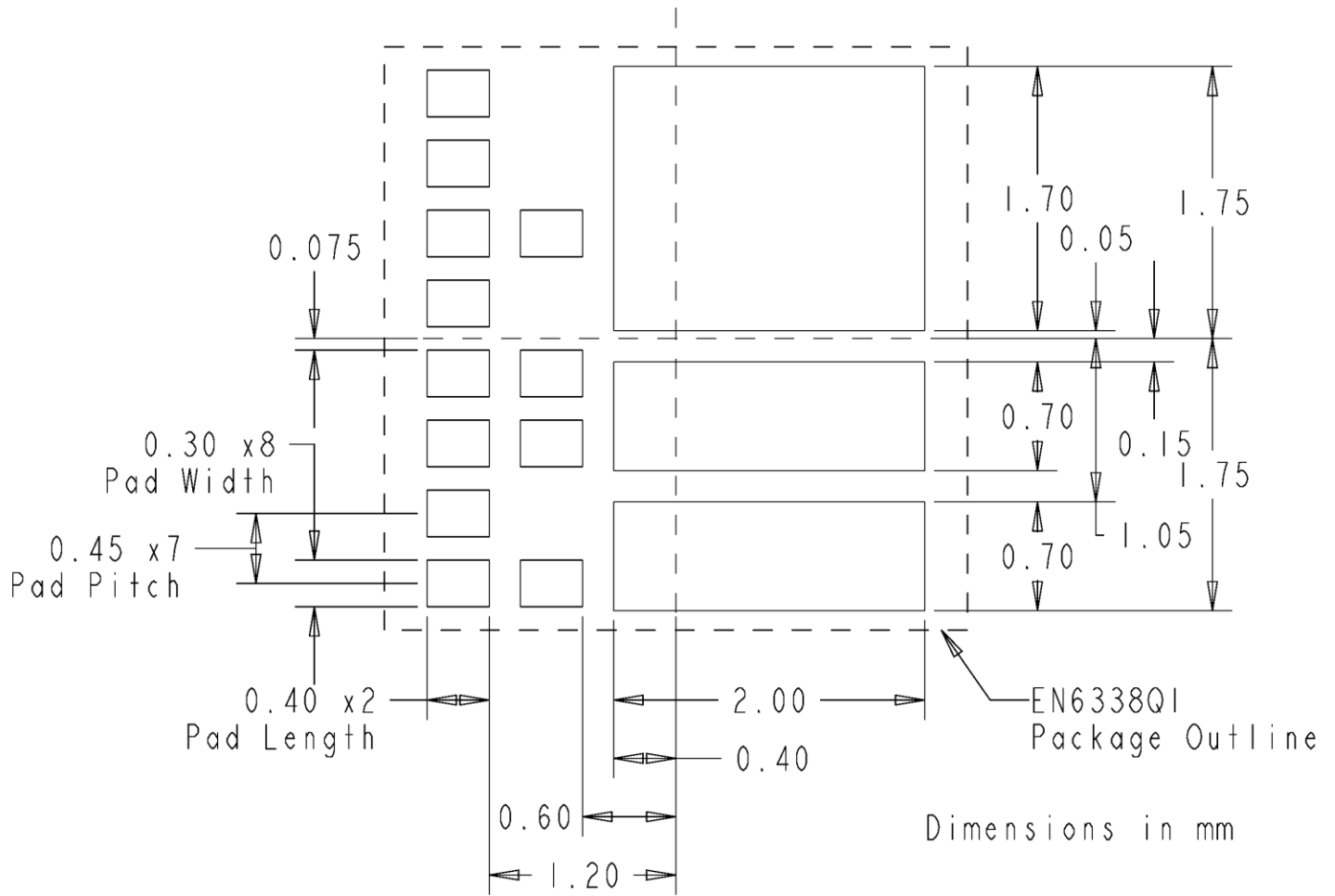
plane. Put the vias under the capacitors along the edge of the GND copper closest to the Voltage copper. Please see Figure 11. These vias connect the input/output filter capacitors to the GND plane, and help reduce parasitic inductances in the input and output current loops. If the vias cannot be placed under  $C_{IN}$  and  $C_{OUT}$ , then put them just outside the capacitors along the GND slit separating the two components. Do not use thermal reliefs or spokes to connect these vias to the ground plane.

**Recommendation 5:** AVIN is the power supply for the internal small-signal control circuits. It should be connected to the input voltage at a quiet point. In Figure 11 this connection is made at the input capacitor furthest from the PVIN pin and on the input source side. Avoid connecting AVIN near the PVIN pin even though it is the same node as the input ripple is higher there.

**Recommendation 6:** The  $V_{OUT}$  sense point should be connected at the last output filter capacitor furthest from the VOUT pins (near C6). Keep the sense trace as short as possible in order to avoid noise coupling into the control loop.

**Recommendation 7:** Keep  $R_A$ ,  $C_A$ ,  $R_C$  and  $R_B$  close to the VFB pin (see Figure 11). The VFB pin is a high-impedance, sensitive node. Keep the trace to this pin as short as possible. Whenever possible, connect  $R_B$  directly to the AGND pin instead of going through the GND plane. The AGND should connect to the PGND at a single point from the AGND pin to the PGND plane on the 2<sup>nd</sup> layer.

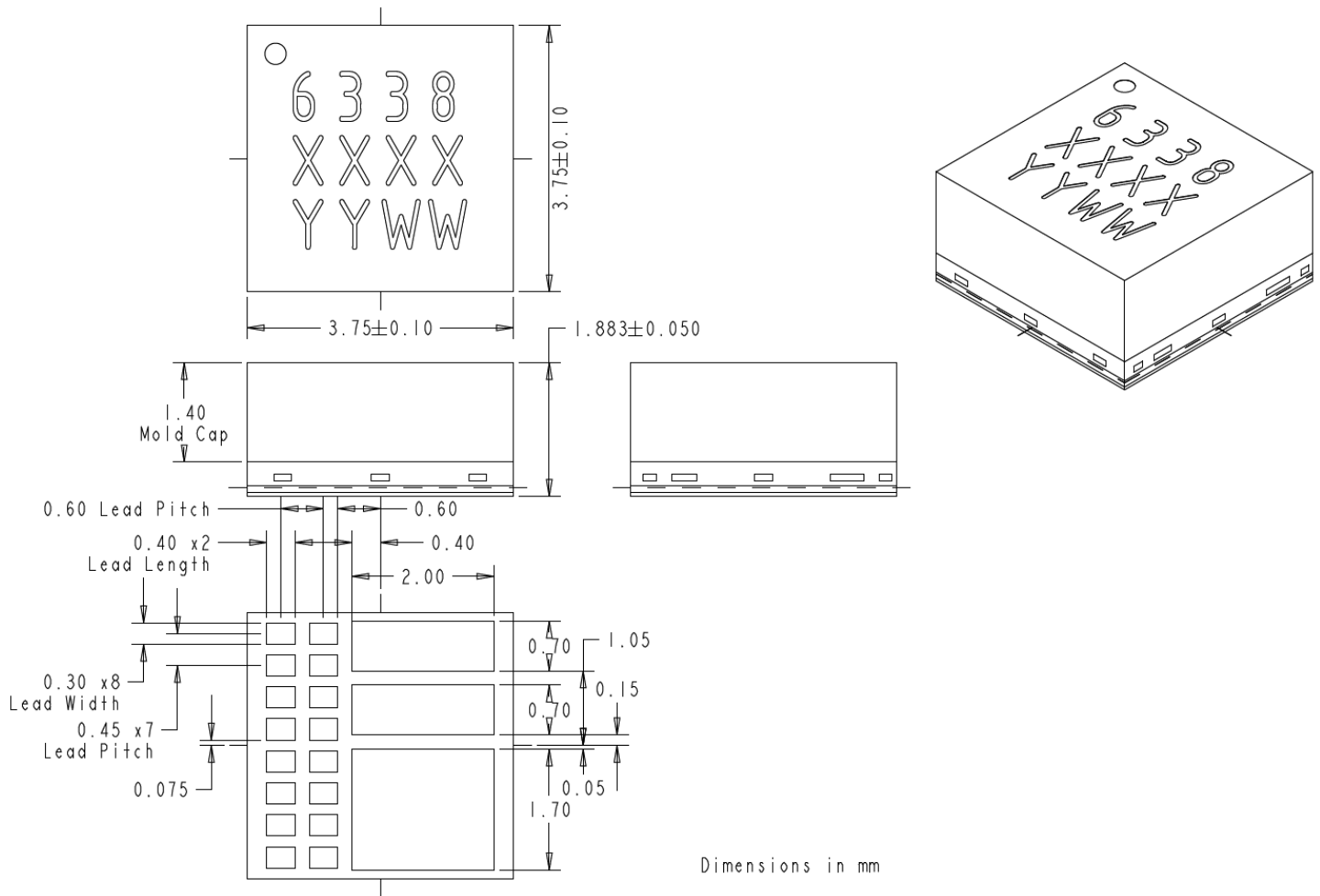




**Figure 12: Landing Pattern with Solder Stencil (Top View)**

The solder stencil aperture for the thermal PGND pad is shown in Figure 12 and is based on Enpirion power product manufacturing specifications.

## PACKAGE DIMENSIONS



**Figure 13: EN6338QI Package Dimensions**

### Packing and Marking Information:

<https://www.intel.com/content/www/us/en/programmable/support/quality-and-reliability/packing.html>

## REVISION HISTORY

Rev	Date	Change(s)
A	June, 2018	Initial Release
B	August, 2018	Removed the typo “Line” in V <sub>OUT</sub> Accuracy Spec of Features section on Page 1
C	November, 2018	<ul style="list-style-type: none"> <li>• Updated Packaging description from aEASI to LGA</li> <li>• Updated supporting links to Intel.com</li> </ul>

## WHERE TO GET MORE INFORMATION

For more information about Intel® and Enpirion® PowerSoCs, visit:

[www.intel.com/enpirion](http://www.intel.com/enpirion)

© 2017 Intel Corporation. All rights reserved. Intel, the Intel logo, Altera, ARRIA, CYCLONE, ENPIRION, MAX, MEGACORE, NIOS, QUARTUS, and STRATIX words and logos are trademarks of Intel Corporation or its subsidiaries in the U.S. and/or other countries. Other marks and brands may be claimed as the property of others. Intel reserves the right to make changes to any products and services at any time without notice. Intel assumes no responsibility or liability arising out of the application or use of any information, product, or service described herein except as expressly agreed to in writing by Intel. Intel customers are advised to obtain the latest version of device specifications before relying on any published information and before placing orders for products or services.

\* Other marks and brands may be claimed as the property of others.