



ENH181E1-220 Color TFT-LCD Module Features

GENERAL DESCRIPTION

Panelview provides optically enhanced solutions to the standard Sharp LQ181E1W31 color active matrix LCD module. Contact enhancement is provided by the use of index matching (IM) film lamination to the front surface of the display polarizer. The IM film is available in two surface treatments - IM/Clear and IM/110 (a 10% diffusion).

This module is composed of a color TFT-LCD panel, driver ICs, control circuit, power supply circuit and a backlight unit. Graphics and text can be displayed on a 1280 ~ 3 ~ 1024 dot panel with 16 million colors (8bit) by using LVDS (Low Voltage Differential Signaling) to interface and supplying +12V DC supply voltage for TFT-LCD panel driving and supply voltage for backlight. It is a wide viewing-angle-module.

Backlight-driving DC/AC inverter is not built in this module.

Panelview assumes no responsibility for any damage resulting from the use of the device which does not comply with the instructions and the precautions specified in these specification sheets. Panelview does assume the responsibility for the warranty of the enhanced product.

MECHANICAL SPECIFICATIONS

Parameter	Specifications	Units
Display size	46 Diagonal	cm
	18.1 Diagonal	inch
Active area	359.0 (H) x 287.2 (V)	mm
Pixel format	1280 (H) x 1024 (V)	pixel
	(1 pixel=R=G=B dots)	-
Pixel pitch	0.2805 (H) x 0.2805 (V)	mm
Pixel configuration	R,G,B vertical stripe	-
Display mode	Normally Black	-
Unit outline dimensions (1)	389 (W) x 317.2 (H) x 27.5(D)	mm
Mass	3.5 (max)	kg
Surface treatment	IM/Clear (glossy) or IM/110 and hardcoat 3H	-

Note:

1. Excluding backlight cables.
The thickness of module (D) does not contain the projection
2. Outline dimensions are shown in Fig 1.



INPUT TERMINALS

TTL-LCD Panel Driving

CN1 (Interface signals and + 12VDC power supply)

Using connector :FFI-SE30P-HF (Japan Aviation Electronics Ind., Ltd.)

Mating connector :FFI-S30S (Japan Aviation Electronics Ind., Ltd.)

Pin No.	Symbol	Function	Remark
1	V _{cc}	+12V Power Supply	-
2	V _{cc}	+12V Power Supply	-
3	V _{cc}	+12V Power Supply	-
4	GND	GND	-
5	GND	GND	-
6	GND	GND	-
7	SELLVDS	Select LVDS data order	3.3V C-MOS Pull Up (1)
8	NC	NC	-
9	GND	GND	-
10	RxBIN3+	Positive (+) LVDS differential data input (B port)	LVDS
11	RxBIN3-	Negative (-) LVDS differential data input (B port)	LVDS
12	RxBCKIN+	Positive (+) LVDS differential clock input (B port)	LVDS
13	RxBCKIN-	Negative (-) LVDS differential clock input (B port)	LVDS
14	RxBIN2+	Positive (+) LVDS differential data input (B port)	LVDS
15	RxBIN2-	Negative (-) LVDS differential data input (B port)	LVDS
16	RxBIN1+	Positive (+) LVDS differential data input (B port)	LVDS
17	RxBIN1-	Negative (-) LVDS differential data input (B port)	LVDS
18	RxBIN0+	Positive (+) LVDS differential data input (B port)	LVDS
19	RxBIN0-	Negative (-) LVDS differential data input (B port)	LVDS
20	RxAIN3+	Positive (+) LVDS differential data input (A port)	LVDS
21	RxAIN3-	Negative (-) LVDS differential data input (A port)	LVDS
22	RxACKIN+	Positive (+) LVDS differential clock input (A port)	LVDS
23	RxACKIN-	Negative (-) LVDS differential clock input (A port)	LVDS
24	RxAIN2+	Positive (+) LVDS differential data input (A port)	LVDS
25	RxAIN2-	Negative (-) LVDS differential data input (A port)	LVDS
26	RxAIN1+	Positive (+) LVDS differential data input (A port)	LVDS
27	RxAIN1-	Negative (-) LVDS differential data input (A port)	LVDS
28	RxAIN0+	Positive (+) LVDS differential data input (A port)	LVDS
29	RxAIN0-	Negative (-) LVDS differential data input (A port)	LVDS
30	GND	GND	-



Note:

- SELLVDS (Thine: THC63LVDM83A)

Transmitter		SELLVDS	
Pin No	Data	=L(GND)	=H(3.3V) or Open
51	TA0	R0(LSB)	R2
52	TA1	R1	R3
54	TA2	R2	R4
55	TA3	R3	R5
56	TA4	R4	R6
3	TA5	R5	R7(MSB)
4	TA6	G0(LSB)	G2
6	TB0	G1	G3
7	TB1	G2	G4
11	TB2	G3	G5
12	TB3	G4	G6
14	TB4	G5	G7(MSB)
15	TB5	B0(LSB)	B2
19	TB6	B1	B3
20	TC0	B2	B4
22	TC1	B3	B5
23	TC2	B4	B6
24	TC3	B5	B7(MSB)
27	TC4	NC	NC
28	TC5	(RSV1)	(RSV1)
30	TC6	DE	DE
50	TD0	R6	R0(LSB)
2	TD1	R7(MSB)	R1
8	TD2	G6	G0(LSB)
10	TD3	G7(MSB)	G1
16	TD4	B6	B0(LSB)
18	TD5	B7(MSB)	B1
25	TD6	(NA)	(NA)



SELLVDS= Low(GND)

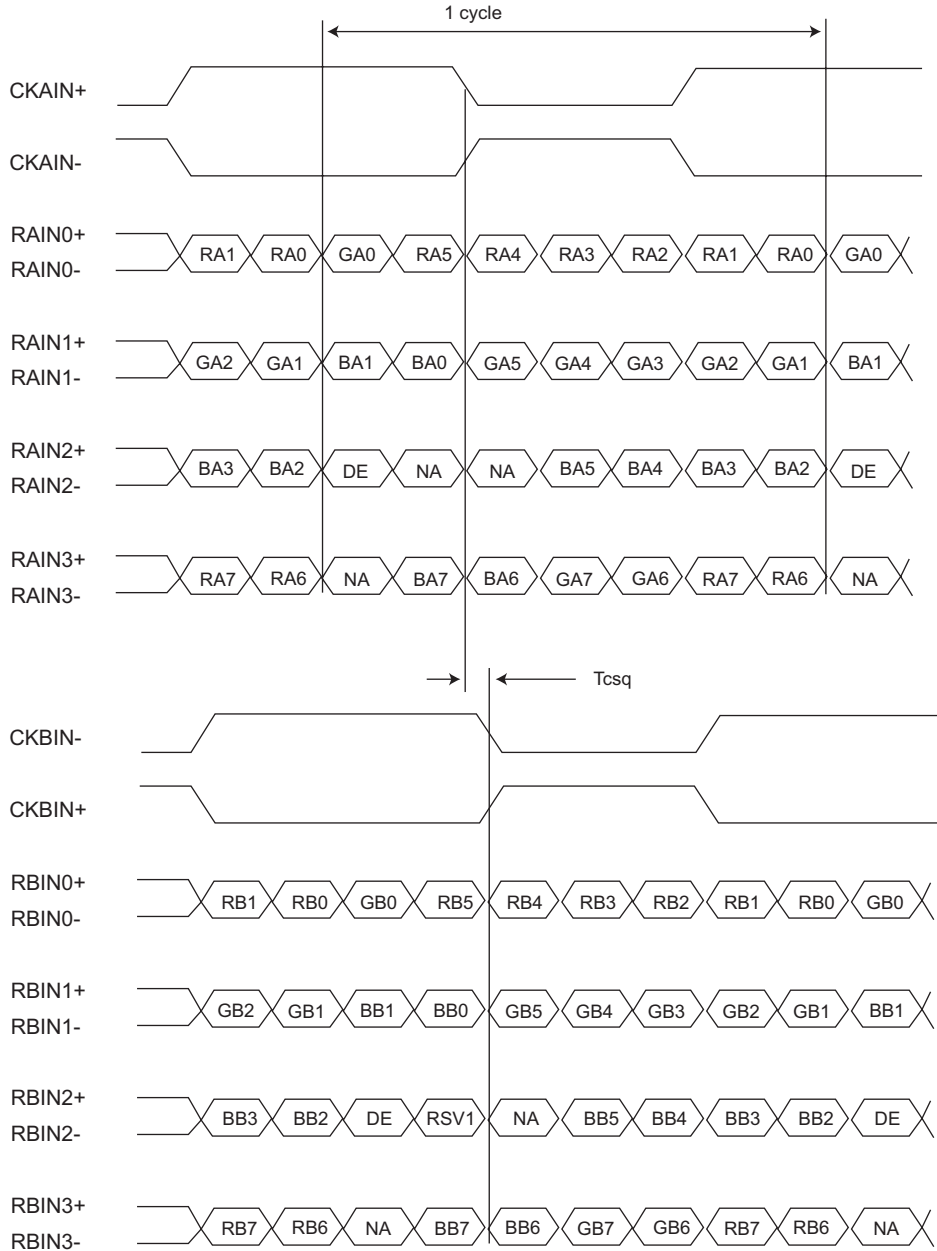

DE: Display Enable
RSV1: Reserve (Fixed GND)
NA: Not Available



SELLVDS= High(3.3V) or Open

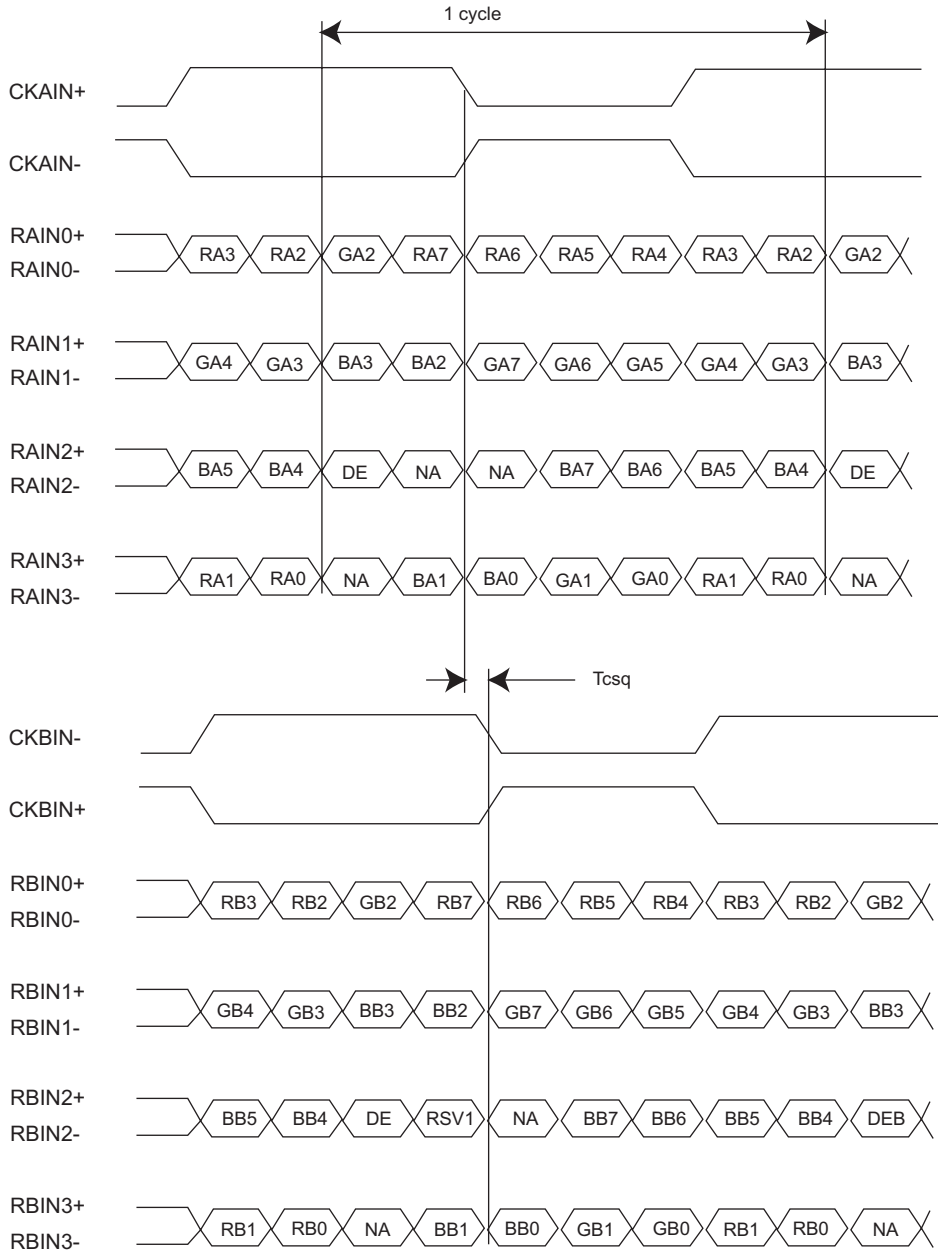

DE: Display Enable
RSV1: Reserve (Fixed GND)
NA: Not Available



INTERFACE BLOCK DIAGRAM

Using receiver: Contained in a control IC.

Corresponding Transmitter: THC63LVDM83A (THine electronics), DS90C383, DS90C383A (National semiconductor)

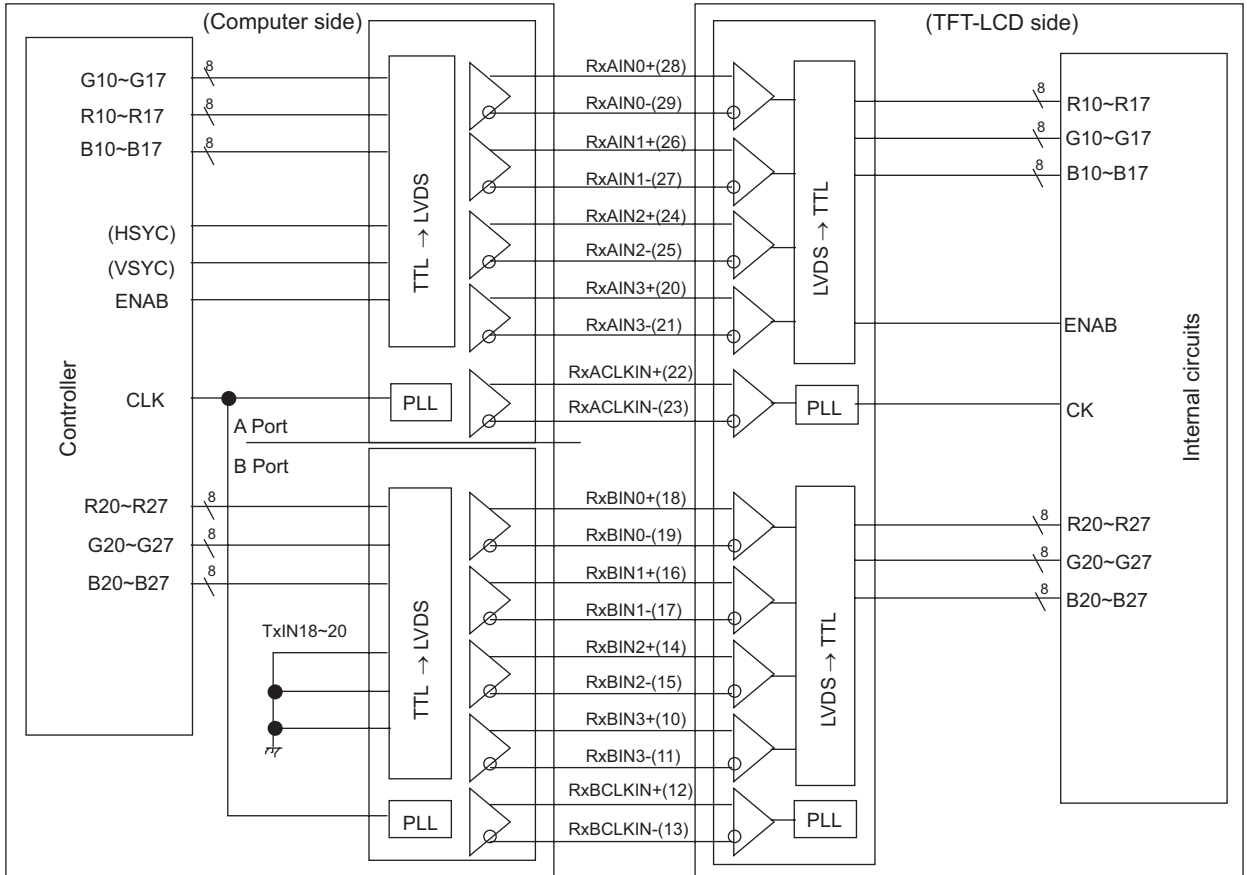

Fig. 2 Interface block diagram



BACKLIGHT DRIVING

CN2, CN3 The module-side connector: BHR-03VS-1(JST)
The user-side connector SM02B-BHSS(JST)

Pin No.	Symbol	I/O	Function
1	V _{HIGH}	I	Power supply for lamp (High voltage side)
3	V _{LOW}	I	Power supply for lamp (Low voltage side)

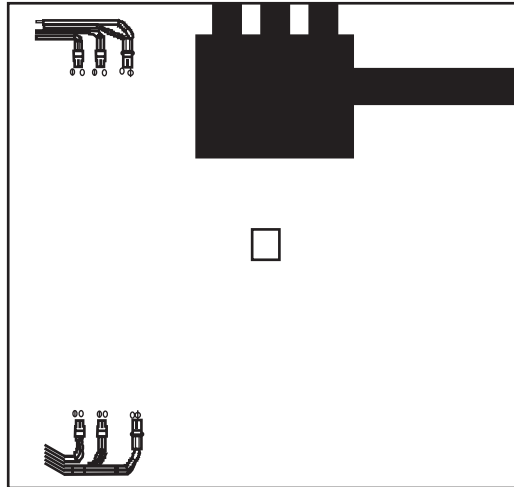

ABSOLUTE MAXIMUM RATINGS
MODULE

Parameter	Symbol	Condition	Ratings	Unit	Remark
Storage temperature (2)	i _{STG}	-	-25~ + 60	°C	
Operating temperature (Ambient)(2)	T _{OPA}	-	0~ + 50	°C	

Notes:

- 1 Humidity: 95%RH Max. at t_A ≤ 40°C.
Maximum wet-bulb temperature at 39°C or less at t_A ≤ 40°C.
No condensation.

TFT-LCD PANEL DRIVING

Parameter	Symbol	Condition	Ratings	Unit
+12.0V supply voltage	V _{CC}	t _A =25°C	0~ + 14.0	V



ELECTRICAL CHARACTERISTICS

TFT-LCD PANEL DRIVING, $t_a=25^\circ\text{C}$

Parameter	Symbol	MIN	TYP	MAX	Unit	Remarks
V_{CC}	Supply voltage	$+11.4$	$+12.0$	$+12.6$	V	(1)
	Current dissipation	-	350	600	mA	(2)
Permissive input ripple voltage	V_{RF}	-	-	100	mVp-p	
Input current (Low)	I_{L}	-	-	10	μA	$V_i=\text{GND}$
Input current (High)	I_{H}	-	-	10	μA	$V_i=V_{CC}$

Note: 1)

- On-Off conditions for supply voltage
 $0 < t_1 \leq 60\text{ms}$
 $0 < t_2 \leq 10\text{ms}$
 $0 < t_3 \leq 1\text{s}$
 $t_4 \geq 100\text{ms}$

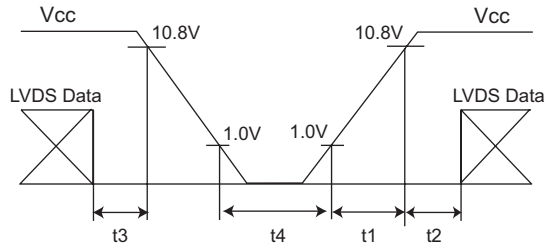

- Dip conditions for supply voltage

$V_{MIN}=11.4\text{V}$, $V_t=9.6\text{V}$

- $V_t \leq V_{CC} < V_{MIN}$
 $t_d \leq 20\text{ms}$

- $V_{CC} < V_t$
This case is described below *1

*1 The LCD module shuts down when $V_{CC} < V_t$
It should also follow the 1. on-off sequence of V_{CC} and data

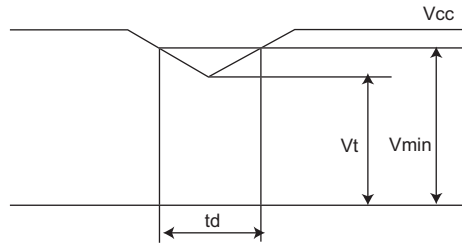

Note: 2)

- Typical current situation: 16-gray-bar pattern
 $V_{CC}=12.0\text{V}$,
 Gray scale: GS(16n)
 $N=0\sim 15$
 The explanation of each gray scale, GS(4n), is described on page 12.

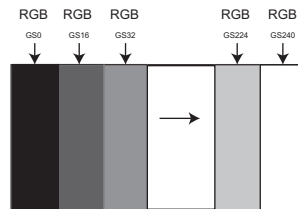

- Maximum current situation:
The dots described in the figure (below, left) are displaying the gray scale described the following figure (below, right).

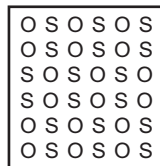
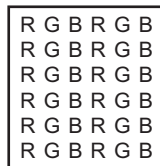

O = V0 gray scale
S = V255 gray scale

The voltage corresponds with one of the 256 gray scale



BACKLIGHT DRIVING SECTION

The backlight system is an edge-lighting type with single CCFT (Cold Cathode Fluorescent Tube).

The characteristics of a single lamp are shown in the following table. $t_a=25^\circ\text{C}$

The value mentioned below is at the case of one CCFT.

Parameter	Symbol	MIN	TYP	MAX	Unit	Remark
Lamp current range	I_L	2.5	6.0	7.0	mArms	(1)
Lamp voltage	V_L	-	715	-	Vrms	$t_a=25^\circ\text{C}$
Lamp power consumption	P_L	-	4.3	-	W	(2)
Lamp frequency	F_L	35	60	70	KHz	(3)
Kick-off voltage	V_S	-	-	1300	Vrms	$t_a=25^\circ\text{C}$
		-	-	1500	Vrms	$t_a=0^\circ\text{C}$ (4)
Lamp life time	T_L	50000	-	-	hour	(5)

Notes:

1. A lamp can be lit in the range of the lamp current shown above 35~70.
Maximum rating for current is measured by high frequency current measurement equipment connected to V_{LOW} at circuit shown below. (Note: To keep enough kick-off voltage and necessary steady voltage for CCFT.)
Lamp frequency: 35~70kHz
Ambient temperature: 0~50°C

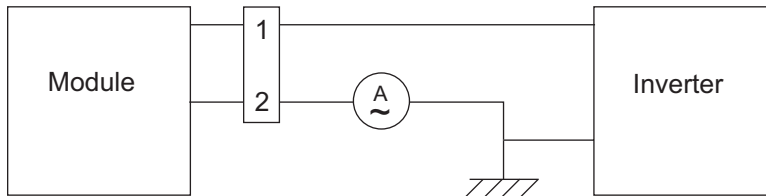

2. Referential data per one CCFT by calculation ($I_L \times V_L$).
3. Lamp frequency may produce interference with horizontal synchronous frequency, and this may cause horizontal beat on the display. Therefore lamp frequency shall be detached as much as possible from the horizontal synchronous frequency and from the harmonics of horizontal synchronous to avoid interference.
4. Kick-off voltage value is described as the index in the state of lamp only. The kick-off voltage value is estimated to be risen up as approx. +200V in the state of module only, and the further rise up can be seen according to the assembling status of user cabinet. Set the kick-off voltage of inverter to avoid the lighting failures in the state of operation. Design the inverter so that its open output voltage can be connected for more than 1 second to startup. Otherwise, the lamp may not be turned on. But, set as 100ms when the ambient luminance around the lamp is more than 1lux.
5. Lamp life time is defined as the time when either (1) or (2) occurs in the continuous operation under the condition of $t_a=25^\circ\text{C}$ and $I_L=6.0 \pm 0.5\text{mArms}$
 1. Brightness becomes 50% of the original value under standard condition.
 2. Kick-off voltage at $t_a=0^\circ\text{C}$ exceeds maximum value, 1500 Vrms.

The performance of the backlight, for example life time or brightness, is extremely influenced by the characteristics of the DC-AC inverter for the lamp. When designing or ordering the inverter, make sure that poor lighting caused by the mismatch of the backlight and the inverter (mis-lighting, flicker, etc.) do not occur. Once this is confirmed, the module should be operated in the same condition as it is installed in the instrument.



TIMING CHARACTERISTICS OF INPUT SIGNALS

Timing diagrams of input signal are shown in Fig. 3

PIXEL MODE TIMING CHARACTERISTICS

Parameter		Symbol	Min.	Typ.	Max.	Unit	Remark
Clock	Frequency	$1/T_c$	34	45	67.5	MHz	(1)
	Skew	T_{csq}	-1	0	1	clock	
Data enable signal	Set up time	TH	668	848	928	clock	
			12.5	15	-	μ s	
	Horizontal period (high)	TH _d	640	640	640	clock	
	Vertical period	TV	1026	1066	1080	line	(2)
	Vertical period (high)	TH _v	1024	1024	1024	line	

Notes:

- Two pixel-data are sampled at the same time.
- In case of lower frequency, deterioration of the display quality, flicker, etc. may occur. There should be integral horizontal period per one vertical period.

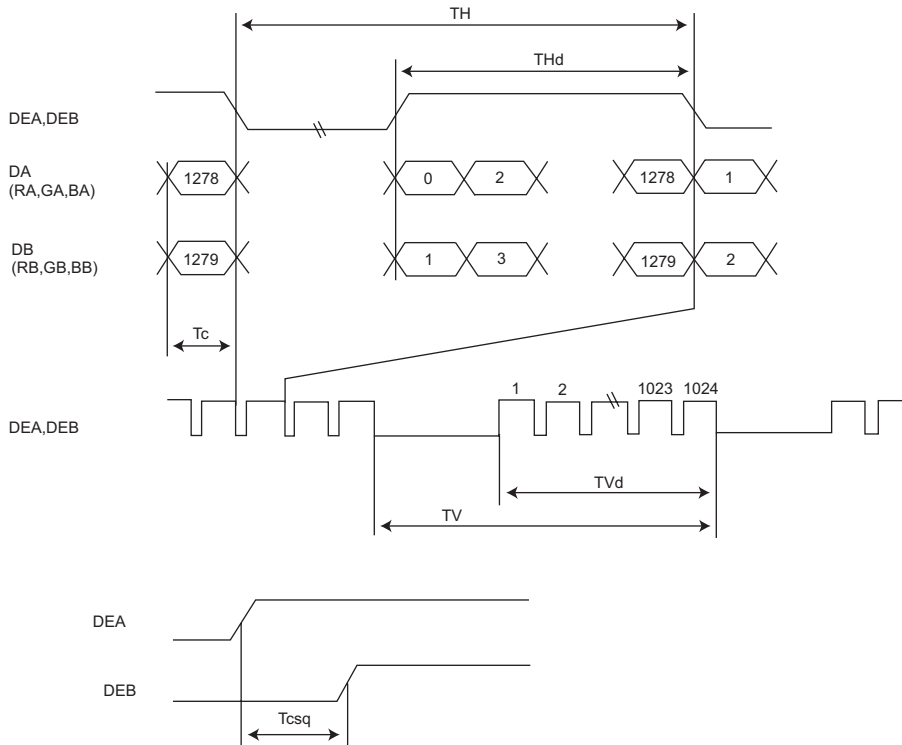

Fig. 3 Timing diagrams of input signal



Input Data Signals and Display Position on the Screen

Graphics and text can be displayed at 1280 x 3 x 1024 dots on a panel with 16M color by supplying 48 bit data signal (8bit/color [256 gray scale] x 3 x 2 pixel).

RA	GA	BA	RB	GB	BB
DA (1,1)			DB (1,1)		

Two pixel-data are sampled at the same time.

*DA: RA0~RA7, GA0~GA7, BA0~BA7

*DB: RB0~RB7, GB0~GB7, BB0~BB7

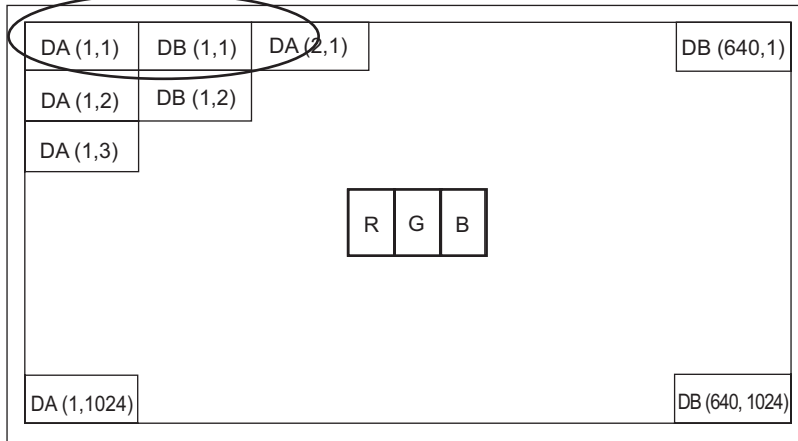

Display position of Input data (H,V)



INPUT SIGNALS, BASIC DISPLAY COLORS AND GRAY SCALE OF EACH COLOR

	Colors & Grayscale	Gray Scale	Data signal																											
			RA0	RA1	RA2	RA3	RA4	RA5	RA6	RA7	GA0	GA1	GA2	GA3	GA4	GA5	GA6	GA7	BA4	BA5	BA2	BA3	BA4	BA5	BA6	BA7				
			RB0	RB1	RB2	RB3	RB4	RB5	RB6	RB7	GB0	GB1	GB2	GB3	GB4	GB5	GB6	GB7	BB4	BB5	BB2	BB3	BB4	BB5	BB6	BB7				
Basic Color	Black	-	0	0	0	0	0	0	0	0	0	0	0	0	0	0	0	0	0	0	0	0	0	0	0	0	0	0		
	Blue	-	0	0	0	0	0	0	0	0	0	0	0	0	0	0	0	0	1	1	1	1	1	1	1	1	1	1		
	Green	-	0	0	0	0	0	0	0	0	0	0	0	0	0	0	0	0	1	1	1	1	1	1	1	1	1	1		
	Cyan	-	0	0	0	0	0	0	0	0	0	0	0	0	0	0	0	0	1	1	1	1	1	1	1	1	1	1		
	Red	-	1	1	1	1	1	1	1	1	1	1	1	1	1	1	1	1	0	0	0	0	0	0	0	0	0	0		
	Magenta	-	1	1	1	1	1	1	1	1	1	1	1	1	1	1	1	0	0	0	0	0	0	0	0	0	0	0		
	Yellow	-	1	1	1	1	1	1	1	1	1	1	1	1	1	1	1	1	1	1	1	0	0	0	0	0	0	0		
	White	-	1	1	1	1	1	1	1	1	1	1	1	1	1	1	1	1	1	1	1	1	1	1	1	1	1	1		
Gray Scale of Red	Black	GS0	0	0	0	0	0	0	0	0	0	0	0	0	0	0	0	0	0	0	0	0	0	0	0	0	0	0		
	↑ Darker	GS1	1	0	0	0	0	0	0	0	0	0	0	0	0	0	0	0	0	0	0	0	0	0	0	0	0	0		
		GS2	0	1	0	0	0	0	0	0	0	0	0	0	0	0	0	0	0	0	0	0	0	0	0	0	0	0		
	↓ Brighter	GS250	1	0	1	1	1	1	1	1	1	1	1	1	1	1	1	1	0	0	0	0	0	0	0	0	0	0		
		GS251	0	1	1	1	1	1	1	1	1	1	1	1	1	1	1	1	0	0	0	0	0	0	0	0	0	0		
	Red	GS252	1	1	1	1	1	1	1	1	1	1	1	1	1	1	1	0	0	0	0	0	0	0	0	0	0	0		
	Gray Scale of Green	Black	GS0	0	0	0	0	0	0	0	0	0	0	0	0	0	0	0	0	0	0	0	0	0	0	0	0	0	0	
		↑ Darker	GS1	0	0	0	0	0	0	0	0	0	0	0	0	0	0	0	0	1	0	0	0	0	0	0	0	0	0	
GS2			0	0	0	0	0	0	0	0	0	0	0	0	0	0	0	0	0	1	0	0	0	0	0	0	0	0		
↓ Brighter		GS250	0	0	0	0	0	0	0	0	0	0	0	0	0	0	0	0	1	0	1	1	1	1	1	1	1	1		
		GS251	0	0	0	0	0	0	0	0	0	0	0	0	0	0	0	0	0	1	1	1	1	1	1	1	1	1		
Green		GS252	0	0	0	0	0	0	0	0	0	0	0	0	0	0	0	0	1	1	1	1	1	1	1	1	1	1		
Gray Scale of Blue		Black	GS0	0	0	0	0	0	0	0	0	0	0	0	0	0	0	0	0	0	0	0	0	0	0	0	0	0	0	
		↑ Darker	GS1	0	0	0	0	0	0	0	0	0	0	0	0	0	0	0	0	0	0	0	0	0	0	0	0	0	0	
	GS2		0	0	0	0	0	0	0	0	0	0	0	0	0	0	0	0	0	0	0	0	0	0	0	0	0	0		
	↓ Brighter	GS250	0	0	0	0	0	0	0	0	0	0	0	0	0	0	0	0	0	0	0	0	0	0	0	0	0	0		
		GS251	0	0	0	0	0	0	0	0	0	0	0	0	0	0	0	0	0	0	0	0	0	0	0	0	0	0		
	Blue	GS252	0	0	0	0	0	0	0	0	0	0	0	0	0	0	0	0	0	0	0	0	0	0	0	0	0	0		

- Notes:
- 0: Low level voltage 1: High level voltage.
 - Each basic color can be displayed in 256 gray scales from 8 bit data signals.
 - According to the combination of total 48 bit data signals, the 16-million-color display can be achieved on the screen.



OPTICAL CHARACTERISTICS

t_A=25°C, V_{CC}=+12V

Parameter		Symbol	Condition	Min	Typ	Max	Unit	Remarks
Viewing Angle Range	Horizontal	θ21, θ22	CR=10	70	85	-	Deg.	(1, 4)
	Vertical	θ11		70	85	-	Deg.	
		θ12		70	85	-	Deg.	
Contrast Ratio		CR	θ = 0°	-	400	-	-	(2, 4)
Response Time	Rise	t _r		-	20	50	ms	(3, 4)
	Decay	t _d		-	5	25	ms	
Chromaticity of White		W _x		0.278	0.308	0.338	-	(4)
		W _y		0.290	0.320	0.350	-	
Chromaticity of Red		R _x		0.612	0.642	0.672	-	(4)
		R _y		0.309	0.339	0.369	-	
Chromaticity of Green		G _x		0.260	0.290	0.320	-	(4)
		G _y		0.578	0.608	0.638	-	
Chromaticity of Blue		B _x		0.113	0.143	0.173	-	(4)
		B _y	0.055	0.085	0.115	-		
Luminance of white		Y _L	180	220	-	cd/m ²	IL=6.0mArms FL=60KHz(4)	
White Uniformity		δw	-	-	1.25	-	(5)	

Notes:

- The measurements shall be executed 30 minutes after lighting at rating. The optical characteristics shall be measured in a dark room or equivalent state with the method shown in Fig. 4 below.

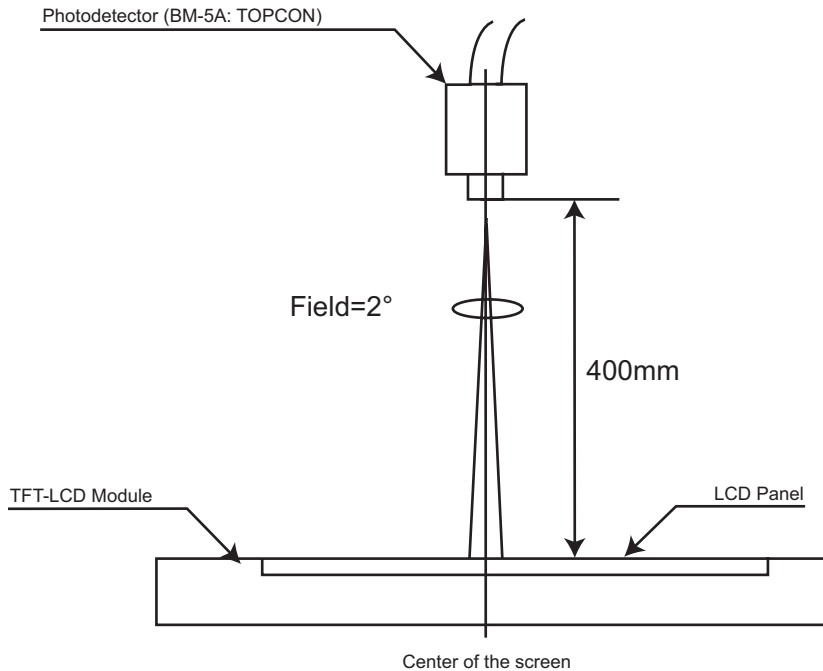
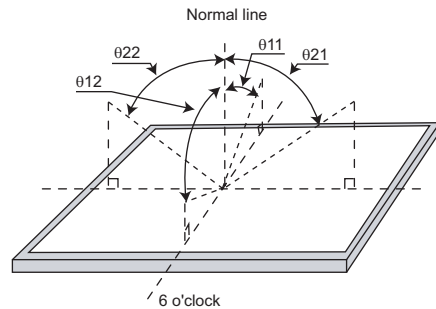

Fig. 4. Optical Characteristics Measurement Method



Notes:

1. Definition of viewing angle range:



2. Definition of contrast ratio

$$\text{Contrast Ratio (CR)} = \frac{\text{Luminance (brightness) with all pixels white}}{\text{Luminance (brightness) with all pixels black}}$$

3. Definition of response time

The response time is defined as the following figure and shall be measured by switching the input signal for "black" and "white".

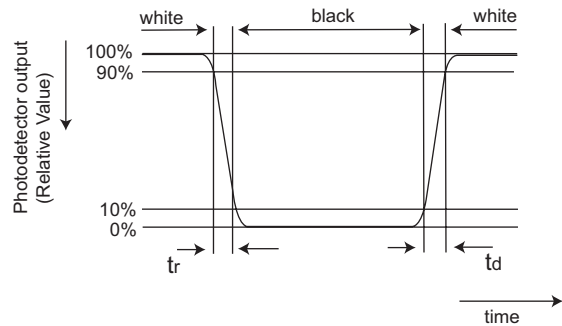

4. This shall be measured at the center of the screen.

5. Definition of white uniformity:

White uniformity is defined as the following with five measurements.

(A-E).

$$\delta_w = \frac{\text{Maximum Luminance of five points (brightness)}}{\text{Minimum Luminance of five points (brightness)}}$$

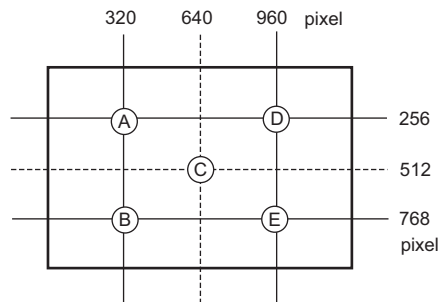



HANDLING PRECAUTIONS

1. Be sure to turn off the power supply when inserting or disconnecting the cable.
2. Be sure to design the cabinet so that the module can be installed without any extra stress such as warp or twist.
3. Since the front polarizer is easily damaged, pay attention not to scratch it.
4. Wipe off water drop immediately. Long contact with water may cause discoloration or spots.
5. If panel surface is soiled, wipe it with absorbent cotton or other soft cloth.
6. Since the panel is made of glass, it may break crack or internal wire breaking if dropped or bumped on hard surface. Handle with care.
7. Since CMOS LSI is used in this module, take care of static electricity and injure the human earth when handling.
8. Make sure the four mounting holes of the module are grounded sufficiently. Take electro-magnetic interference (EMI) into consideration.
9. This module has some printed circuit boards (PCBs) on the back side. Keep them from any stress or pressure when handling or installing the module; otherwise some of the electronic parts on the PCSs may be damaged.
10. Observe all other precautionary requirements in handling components.
11. When some pressure is added onto the module from rear side constantly, it causes display non-uniformity issues, functional defect, etc. Such a design should be avoided.
12. When handling LCD modules and assembling them into cabinets, be aware that long-term storage in an environment of oxidization or deoxidization gas and the use of such materials are reagent, solvent, adherent, resi, ect. which generate these gases, may cause corrosion and discoloration of the LCD module.

PACKING FORM

1. Piling number of cartons: max 10 cartons
2. Package quantity in one carton: 2 modules
3. Carton size: 543mm(W)x 463mm(H) x 172mm(D)
4. Total weight of 1 carton filled with full modules: 9.5kg

OTHERS

1. Disassembling the module can cause permanent damage and should be strictly avoided.
2. Image retention may occur when a fixed pattern is displayed for a long period of time.



RELIABILITY TEST ITEMS

No.	Test items	Conditions	
1	High temperature storage test	t _a =60°C	240h
2	Low temperature storage test	t _a =-25°C	240h
3	High temperature and high humidity operating test	t _a =40°C, 95%RH (No condensation)	240h
4	High temperature operating test	t _a =50°C (The panel temp. must be less than 60°C)	240h
5	Low temperature operating test	t _a =0°C	240h
6	Vibration Test (Non-operating)	Waveform Frequency Sweep time Test Period	:Sine Wave :10~57Hz/Vibration width (one side): 0.075mm :58~500Hz/Gravity: 9.8m/s ² :11 minutes :3 hours (1 hour for each direction of X, Y, Z)
7	Shock test (non-operating)	Max gravity Pulse width Direction	:490m/s ² :11 minutes, sine wave :±X, ±Y, ±Z (once for each direction.)
8	Thermal Shock test	t _a =-20°C ~ 60°C; 50 cycles Test period	: 10 hours (1 hour for each temperature)
9	Altitude	t _a =-50°C, 70kPa, 3, 048m (10,000ft), T=24h (Operating) t _a =-50°C, 18.75kpa, 12, 192m (40,000ft), t=24h (Storage)	

(Result Evaluation Criteria)

Under the display quality test conditions with normal operation state, there shall be no change which may affect practical display function.

- 6. Material information of LPG (Light Pipe Guide) are labeled on the back of the module.

MATERIAL INFORMATION
>PLASTIC LIGHT GUIDE : PMMA<

- 7. Cold Cathode Fluorescent lamp in LCD PANEL contains a small amount of mercury. Follow local ordinances or regulations for disposal. (Put on the back of the module : Size 64 x 44mm)

COLD CATHODE FLUORESCENT LAMP IN LCD PANEL
CONTAINS A SMALL AMOUNT OF MERCURY. PLEASE
FOLLOWLOCAL ORDINANCES OR REGULATION FOR
DISPOSAL

CARTON STORAGE CONDITIONS

- Temperature 0°C to 40°C
- Humidity 95%RH or less
- Reference conditions 20°C to 35°C, 85%RH or less (summer)
5°C to 15°C, 85%RH or less (winter)
"the total storage time (40°C, 95%/RH) : 24H or less
- Sunlight Be sure to shelter product from direct sunlight.
- Atmosphere The display should not be subjected to harmful gases.
- Notes Be sure to put cartons on palette or base, do not put on floor, and store them away the wall.
Take care of ventilation in warehouse and around cartons, and control changing temperature within limits of natural environment.
- Storage Period 1 Year.

