



www.DataSheet4U.com

OPERATION MANUAL
OF
GYROSTAR[®]

Piezoelectric vibrating Gyroscope

MODEL : ENV-05F-03

Support sensor for
car navigation systems

4.April.2000

PRODUCT ENGINEERING SECTION
SENSOR MODULE DEPARTMENT
CIRCUIT MODULE PRODUCTS DIVISION
MURATA MFG. CO., LTD.

Introduction

This angular velocity sensor employs the principle that a Coriolis force results if an angular velocity is applied to a vibrating object. Murata's unique ceramic bimorph vibrating unit is used as the sensor element unit, thereby enabling piezoelectric ceramics to be used for both excitation and detection. The use of this unit simplifies equipment structure and circuit configuration, thus making it possible to provide outstanding performance.

This sensor can be used for positional control and posture control of a moving object requiring high-precision measurements.

1. Features

- On - Board mount type for easy PCB installation
- Low height of 23mm capable of being installed in a one DIN size box

2. Applications

- Dead reckoning function in car navigation systems
- Satellite antenna positioning for moving object
- Movement memory for accident recorders
- Other objects requiring angular rate detection with high precision

3. Specifications

Type		ENV-05F-03				
Characteristic	Symbol	Condition	MIN.	STD.	MAX.	Unit
Supply voltage	Vcc		+4.5	+5.0	+5.5	VDC
Current consumption	Icc	at Vcc=5.0VDC	-	-	15	mA
Max. angular velocity	Omax		-1/3 PI (-60)	-	+1/3 PI (+60)	rad/s (deg/s)
Output	Vo	angular velocity = 0 at -30~80°C	2.150	2.500	2.850	VDC
Scale factor	Sv	at -10~60°C at -30~80°C	23.0 21.7	25.0 25.0	27.0 28.3	mV/deg/s
Asymmetry CW & CCW			-	-	3	deg/s
Temp. coefficient Scale factor		reference : Ta at -10~60°C at -30~80°C	- -	- -	±5 ±10	%FS
Drift		at -30~80°C	-	-	9	deg/s
Start up		Measure Vo after 5s	-	-	±1	deg/s/10mi
Noise level		10kHz noise	-	-	20	mVrms
Linearity		in the Omax	-	-	0.5	%FS
Response		Phase delay : 90deg	-	10	-	Hz
Dependence on Supply voltage Output			0.8	-	1.2	
Scale factor			0.8	-	1.2	
Operating temp. range	Topr		-30	-	80	°C
Storage temp. range	Tstg		-40	-	85	°C
Weight			-	-	20	g
Dimension			11.5(D) x 19.6(W) x 23.2(H) mm			

All typical values

Unless otherwise specified, ambient temperature Ta= 25±5deg C, Vcc = 5.0 VDC

Use a sensor output load resistance of 100k ohm or more.

4. Dimensions

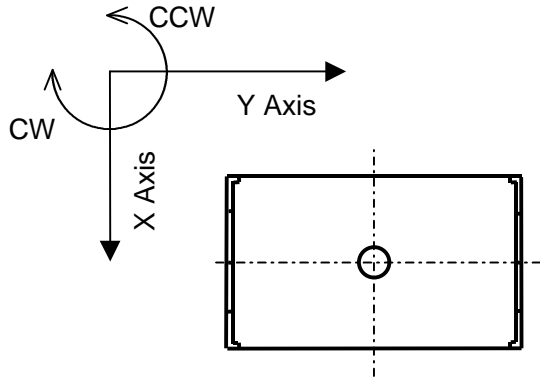

www.DataSheet4U.com

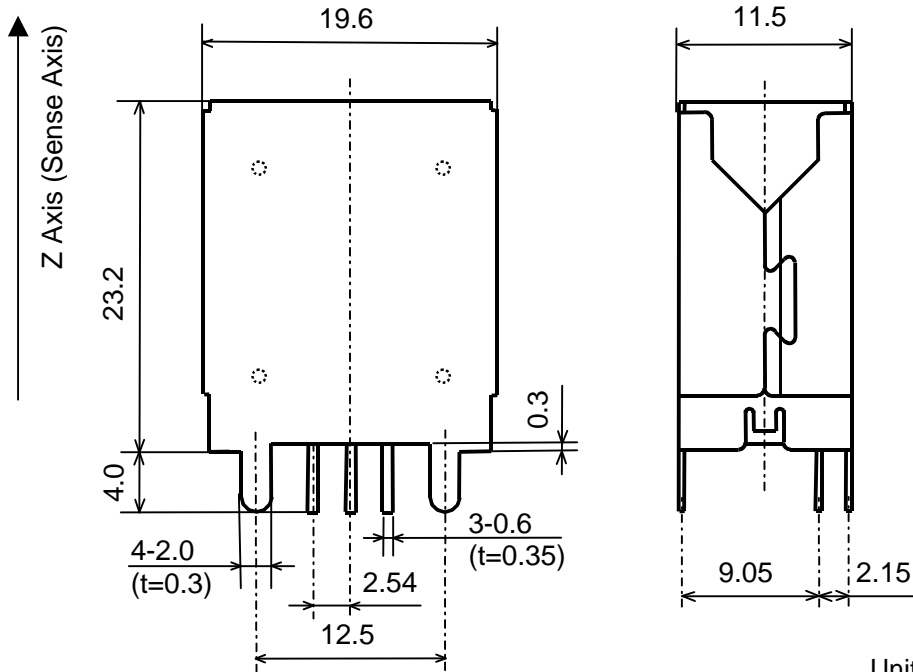

Unit : mm
Tolerance : ± 0.5

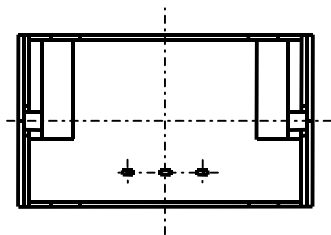

(1) (2) (3)

Terminals	Description
(1)	+Supply (input)
(2)	Ground (common)
(3)	Sensor Output (output)

5. Installation

- 1) Install the sensor with the bottom face as reference.
- 2) Install the sensor vertically with respect to the rotating surface. (90 ± 5 deg)
- 3) Install the sensor in a location free from vibration.
- 4) Install the sensor in a place free from substantial variations in temperature.
- 5) When installing the sensor, solder four tabs and terminals on PCB ($t=1.6$ mm).
- 6) Observe the following rules. If not, characteristics might vary due to soldering heat.

Soldering iron	Flow soldering
Terminal : 350 ± 5 deg C, 5s or less.	Soldering : 250 ± 5 deg C, 5s or less.
Tab : 350 ± 5 deg C, 10s or less.	Preheating : 105 ± 10 degC, 2min. or less.

- 7) Tabs can be bent only once.

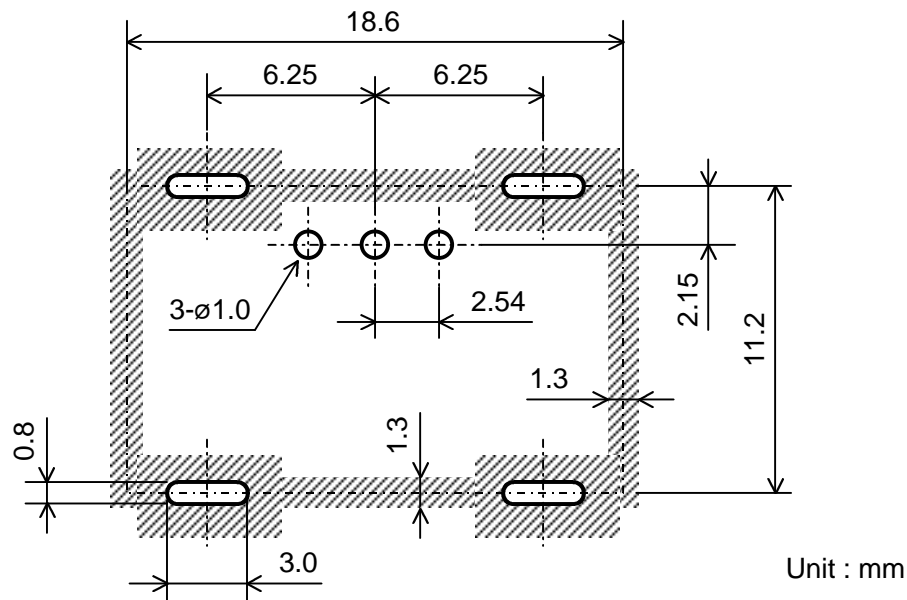

6. Terminal connection

Terminal descriptions

Please refer to page 3 for terminals.

Terminal	Symbol	Descriptions
1	+Vcc	Supply voltage (input)
2	GND	Ground (common)
3	Vout	Sensor output (output)

7. Connection

1) Operation voltage is +4.5V to +5.5V.

Use stabilized power supply free from surge and ripple.

Confirm power supply polarity before connecting sensor.

2) Output voltage is relative to the angular velocity.

$$V_0 + S_v \times O[V]$$

V_0 : Output at angular velocity is 0 [deg/s]

S_v : Scale factor [mV/deg/s]

www.DataSheet4U.com O : Angular velocity [angular velocity range : -80 ~ +80 deg/s]

3) Use a sensor output load resistance of 100k ohm or more.

4) Typical circuit

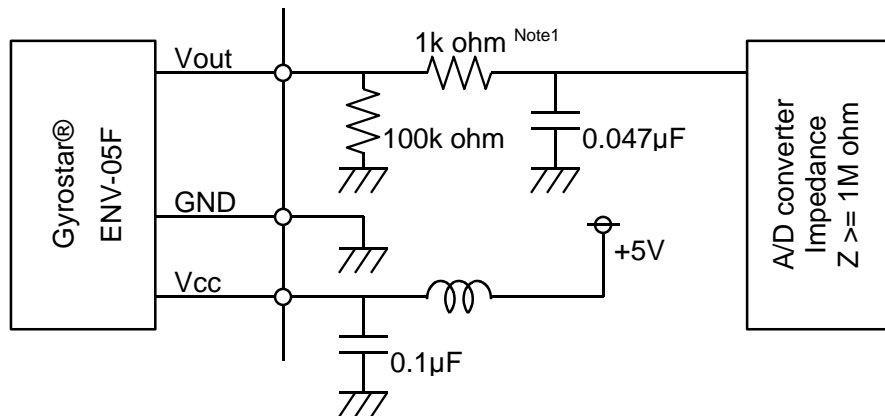

Note1) The value of this resistance should be 1/1000 or less of impedance of A/D converter

8. Notice

1) Bias and scale factor drift

Surrounding temperature variation might affect sensor output (bias, scale factor). Sensor should be mounted where temperature does not vary significantly.

When canceling bias drift, please refer to the following examples.

- Cut DC level of output using HPF (Hi-Pass-Filter) with low cut-off frequency on sensor output.
- If bias voltage can be detected just before measurement, replace former bias with it.

(refer to page 8)

2) Gyrostar detects angular velocity. It is possible to derive relative angle variation from integrating output voltage.

www.DataSheet4U.com

9. Handling

1) Incorrect handling may affect sensor characteristics. Please note the following precautions;

- A. Do not subject the sensor to shocks that exceed the rated limit.
- B. Do not subject the sensor to a magnetic field exceeding $5000\mu\text{T}$ (50 G).
- C. Do not install or store the sensor in a location in which condensation is likely to form on it.
- D. Do not install or store the sensor in a location in which water may splash directly on it.
- E. Do not install or store the sensor in a location in which it is likely to be exposed to salt water or corrosive vapor.

2) Precision electronic parts, such as ICs, are used for the sensor; therefore, it is necessary to take anti-static measures when handling.

3) Do not wash the sensor, It is not water resistant.

4) Do not remove label.

5) Do not disassemble.

10. Application

- 1) When high-precision measurement is required, as in a navigation system, use the output of this sensor through an A/D converter as shown below.
- 2) Positive voltage (+) and negative voltage (-) are obtained in the clockwise and counter clockwise directions, respectively, with the static output as a reference.
- 3) Always use A/D converter of 12 bits or more. Resolution of A/D converter will affect measurement accuracy. Please choose a proper resolution according to the application.
- 4) The sampling frequency used for measurement should be 50 times/sec Min. Sampling frequency will affect measurement accuracy. Please choose a proper sampling frequency according to the application.
- 5) It is possible to derive relative angle variation from integrating the output voltage.

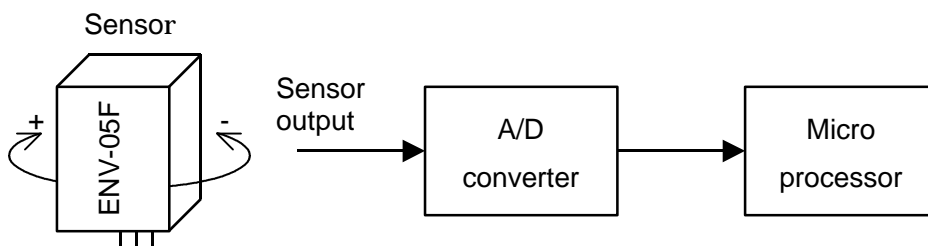

11. Program flow chart for car navigation systems

An example of car navigation systems is shown in below program flow chart.

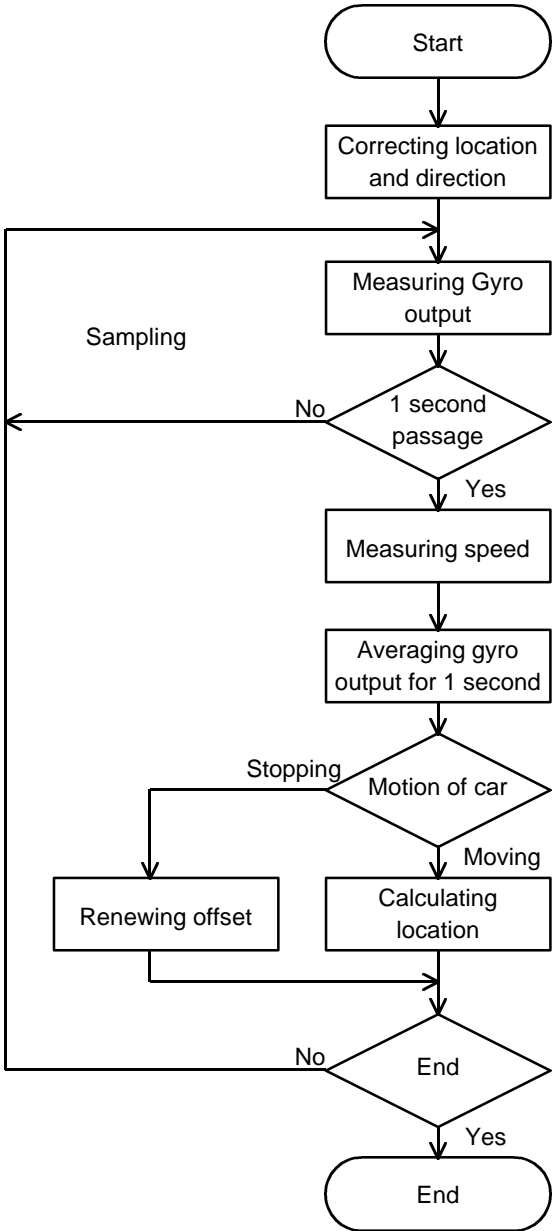

www.DataSheet4U.com

△Note

- 1) Please consult our sales representatives or engineers before using our products listed in this manual for applications requiring especially high reliability what defects might directly cause damage to other party's life, body or property (listed below) or for other applications not specified in this manual.
 1. Aircraft equipment
 2. Aerospace equipment
 3. Undersea equipment
 4. Medical equipment
 5. Traffic signal equipment
 6. Disaster prevention / crime prevention equipment
 7. Data-processing equipment
 8. Applications of similar complexity or with reliability requirements comparable to the applications listed in the above.
- 2) Product specifications in this manual are as of 4.April .2000 and are subject to change or stop the supply without notice. Please confirm the specification before ordering any product. If there are any questions, please contact our sales representatives or engineers.
- 3) The categories and specifications in this manual are for information only. Please confirm detailed specifications by checking the product specification document or requesting for the approval sheet for product specification, before ordering.