

## EPC13 SERIES POWER TRANSFORMER MODULES

### PRODUCT OVERVIEW: SMD POWER TRANSFORMERS

#### Characteristics

Surface Mount  
Core Direction: horizontal  
Functional Insulation

#### Applications

Lighting                      White Goods  
metering                      Telecom  
industrial Controls        DC/DC Converter



#### Bobbin Winding Area

Width (mm)	Build (mm)	Perimeter (mm)
6.8	1.55	21

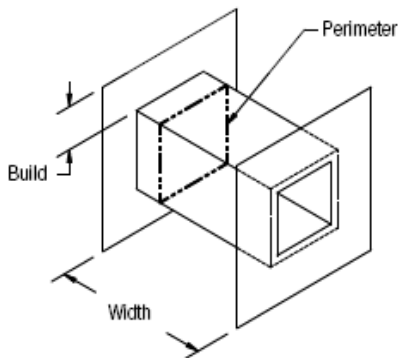

#### CORE DATA

$A_e$ (mm <sup>2</sup> )	$V_e$ (mm <sup>3</sup> )	$L_e$ (mm)
12.78	267	28.7

#### POWER LEVEL (W)

Flyback	Forward	Push-pull
5	7.4	

Test frequency: 100KHz

#### THT Horizontal

Dimensions & Footprint

