

EPH1R5035

[1] Electrical Specification

Output Side $T_a -40 \sim 85^\circ\text{C}$ $V_i 36 \sim 75\text{V}$

	Characteristics	Conditions	Output			Unit
			Min.	Typ.	Max.	
V_o	Output Voltage Initial Setting	$T_a = 25^\circ\text{C}$ $I_o = 0 \sim 3\text{A}$ $V_i = 48\text{V}$	1.42	1.5	1.57	V
	Line Regulation	$I_o = 3.5\text{A}$ $V_i = 36 \sim 75\text{V}$	—	10	—	mV
	Load Regulation	$I_o = 0 \sim 3.5\text{A}$ $V_i = 48\text{V}$	—	60	—	mV
I_o	Output Current		0	—	3.5	A
P_o Max			—	6	—	W
	Output Over Current Limit		3.6	—		A
	Output Over Voltage Protection		1.8	—	2.1	V
	Output Low Voltage Protection		—		1.35	V
V_{oac}	Output Ripple & Noise	$I_o = I_o \text{ Max.}$ $20\text{Hz} \sim 5\text{MHz}$ $0.6\text{Hz} \sim 50\text{MHz}$	—	30	100	mV^{P-P}
			—		80	$\text{dB}\mu\text{V}$

[2] Efficiency & Power Dissipation

	Characteristics	Conditions	Min.	Typ.	Max.	Unit
η	Efficiency	$I_o = 3.5\text{A}$ $V_i = 48\text{V}$	—	79	—	%
P_d	Power Dissipation	$I_o = 3.5\text{A}$ $V_i = 48\text{V}$	—	1.4	—	W

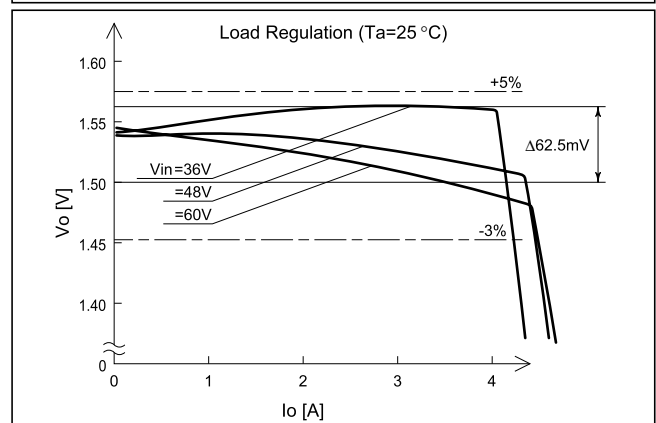
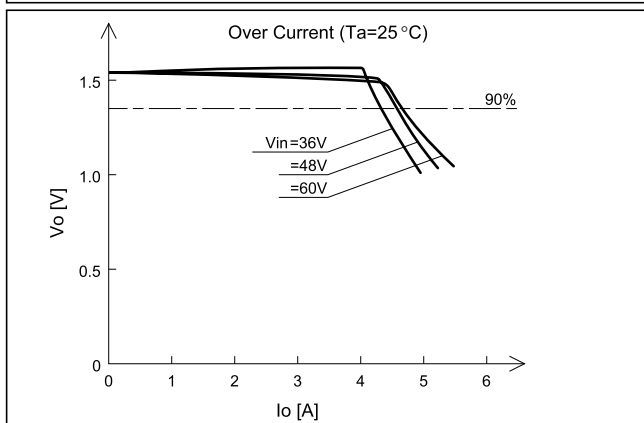
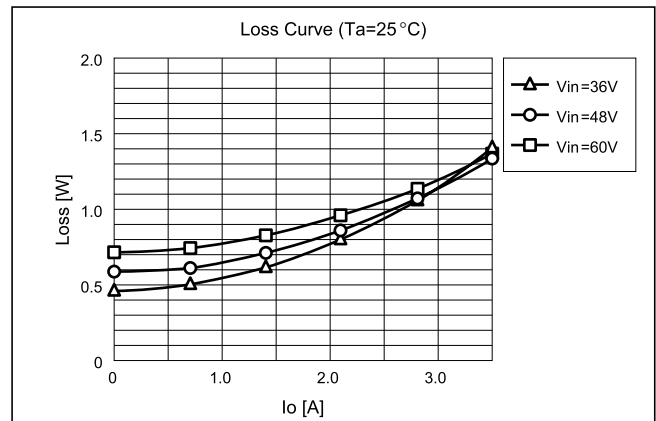
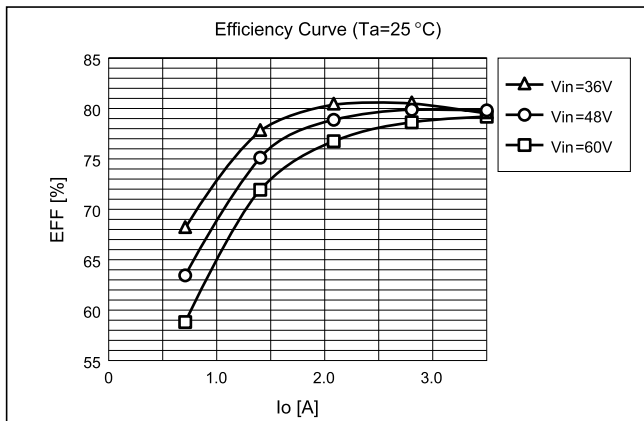

Application 1 [Single operation]

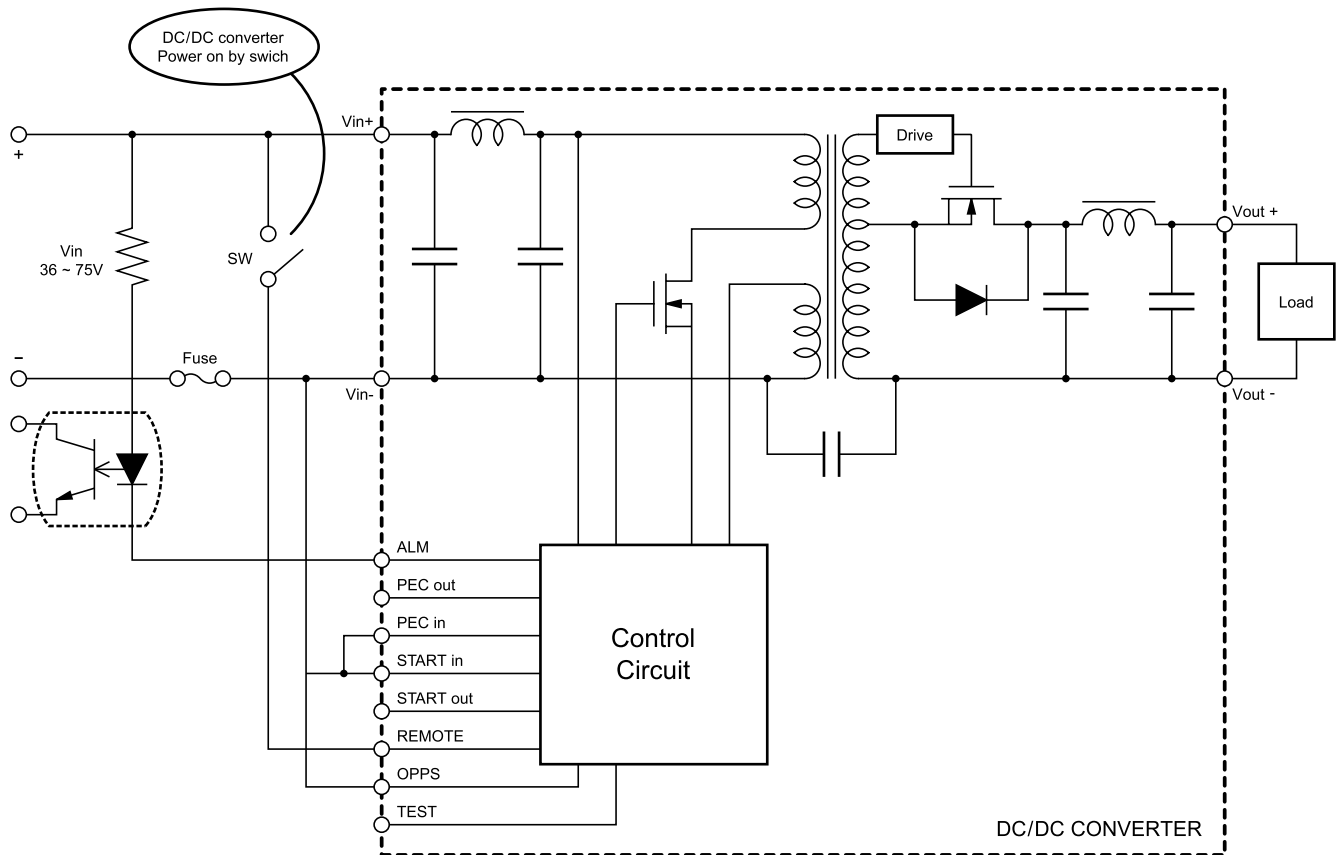

* Please connect from PECin PIN, STARTin PIN, OPSS PIN to Vin-PIN in Natural Convection.

* TEST PIN is always open.

* We recommend to insert fuses (2A) Vin-lines for EPH series.

Application 2 [Parallel operation]

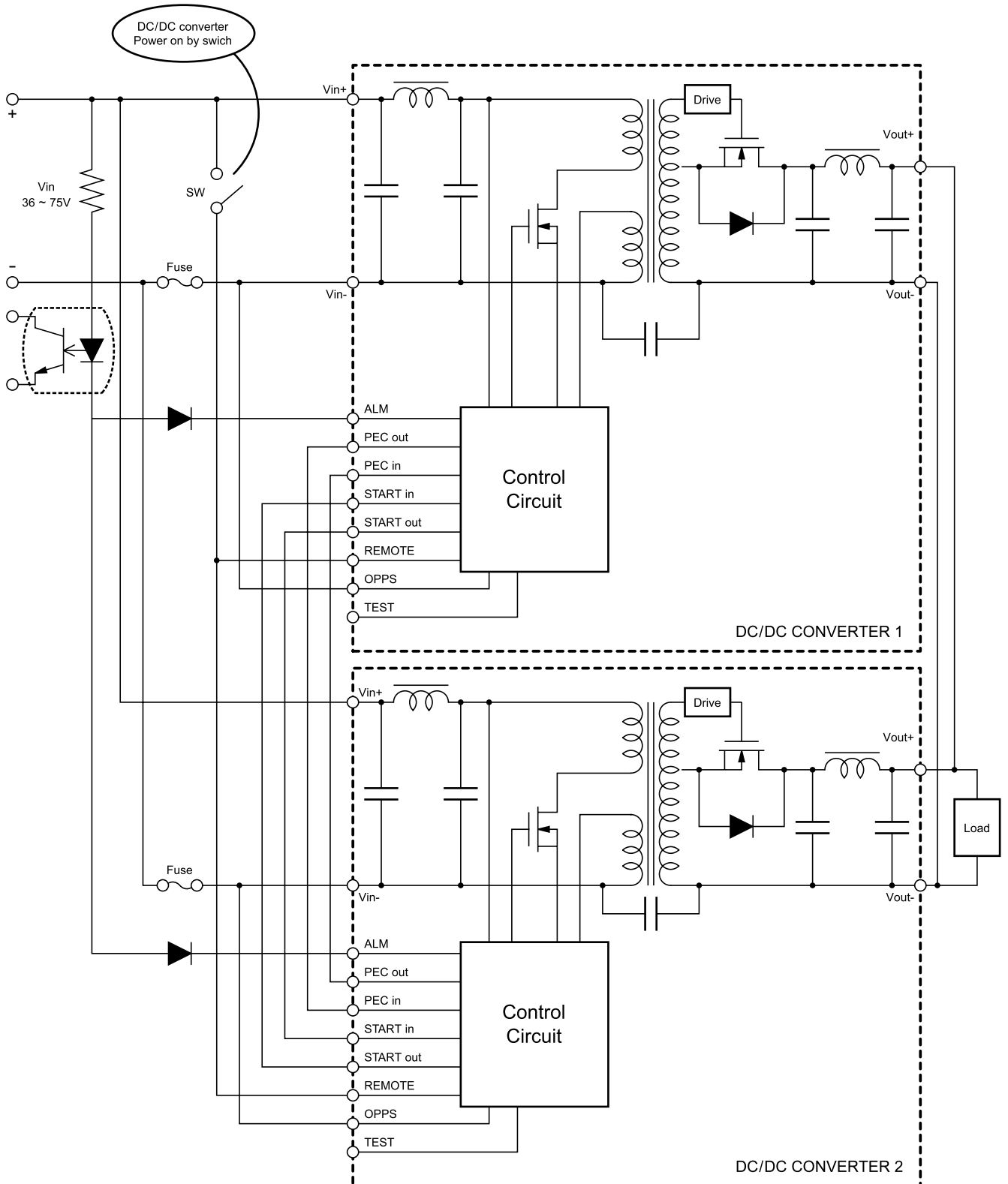

- * Please connect parallel for REMOTE and ALARM signals.
- * Please connect loop line for PEC and START.
- * Please connect from OPPS PIN to Vin-PIN in Natural Convection.
- * TEST PIN is always open.
- * Please insert necessarily fuses (250V 2A) Vin-lines for EPH series.

Package

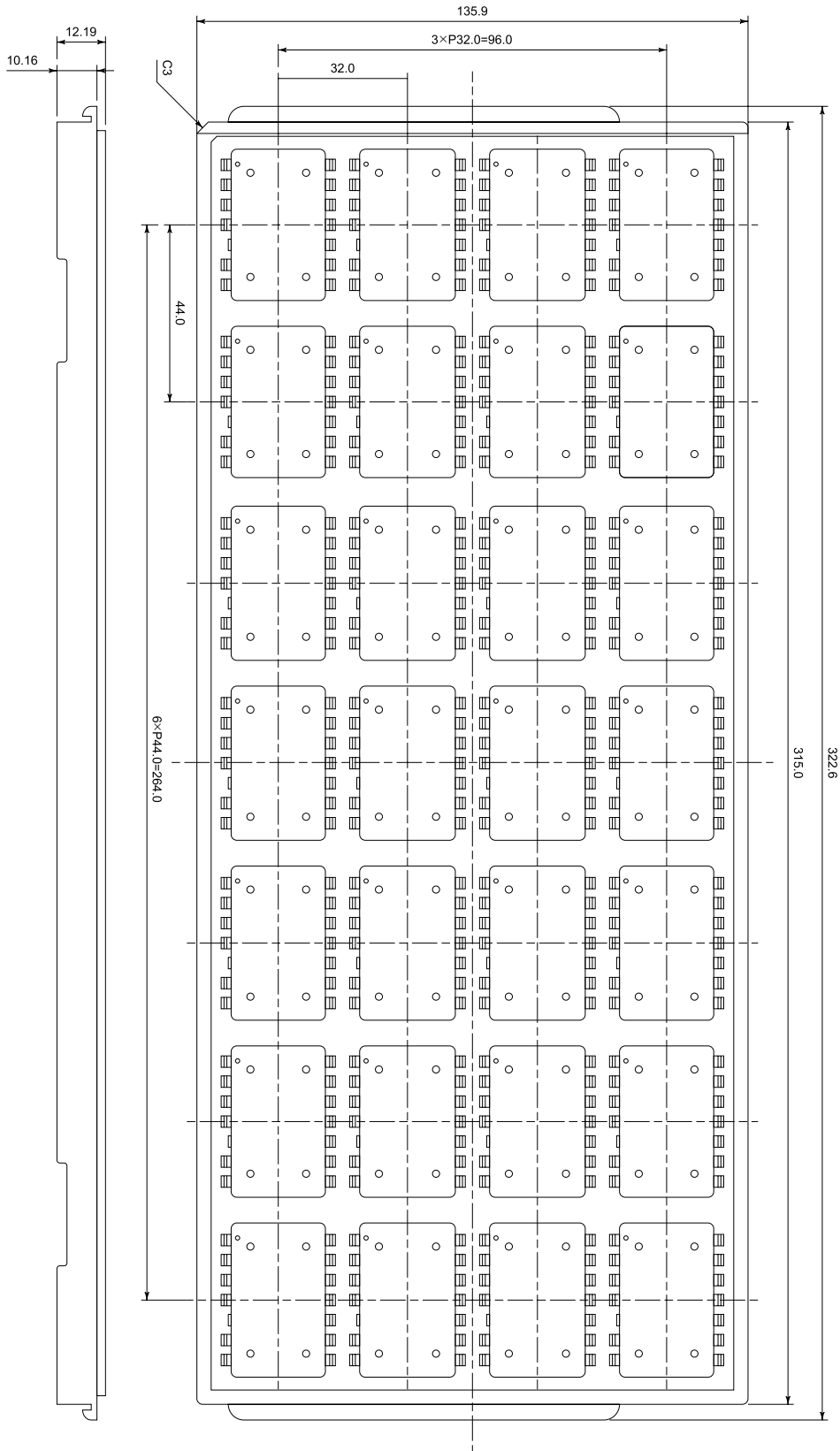

Notes : 1. The shape of the tray complies with JEDEC standards.

2. Product carrying capacity: 28 pcs./tray

3. Heat resistant temperature: 150°C max. (high heat resistance type)

4. The following markings must be indicated on the handle:

1) Company name: Shindengen 2) Package name: MSOP-14 3) Heat resistant temperature 4) Material

■ *Temperature Profile*

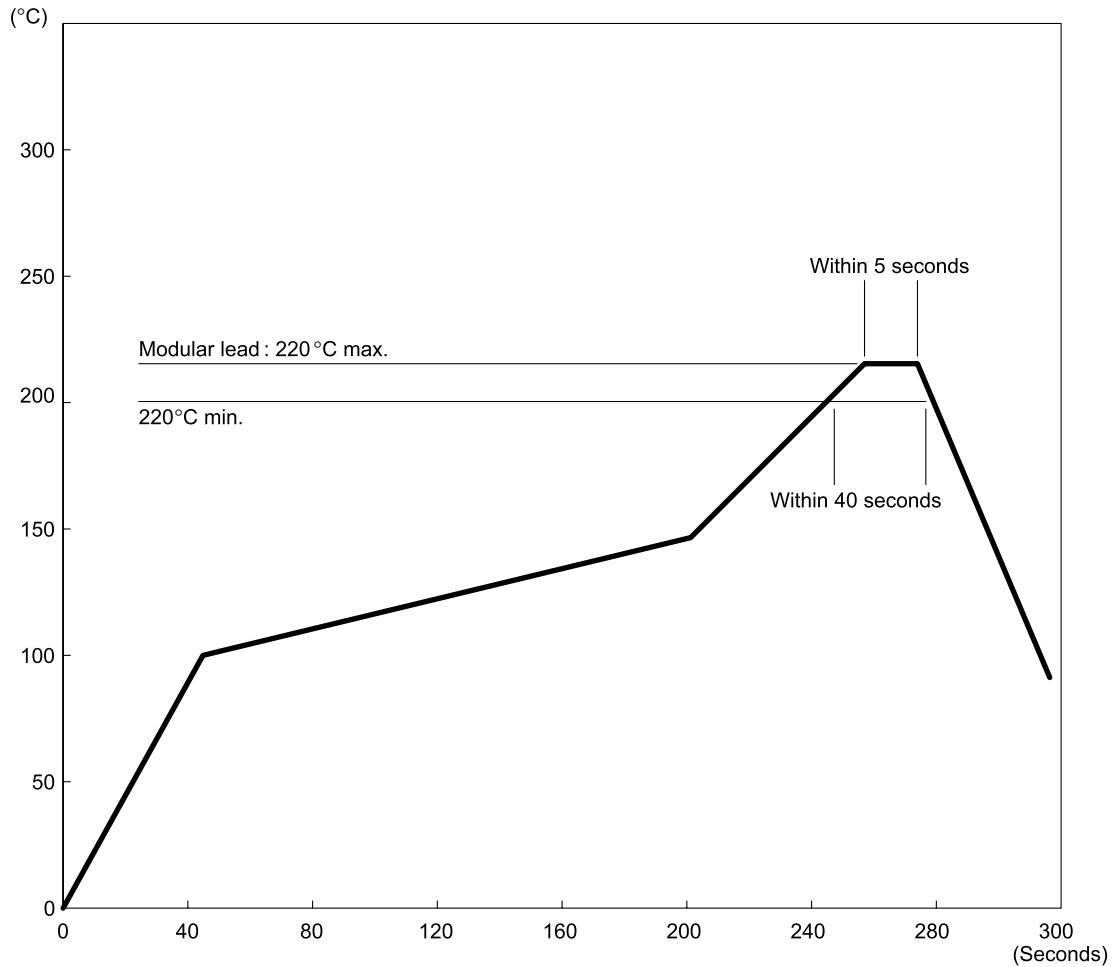

- 1) The atmospheric temperature of the modular lead should be 220°C for no more than 5 seconds.
- 2) Refer to the graph above for an example of a recommended profile.
- 3) Precautions Concerning Heating Method
Since allowing the PWB to stand at a high temperature for an extended period of time may have a detrimental effect on reliability, it is necessary to perform soldering as quickly as possible to prevent the temperature of the PWB from rising excessively.
In addition, since areas of local temperature rise may occur when using a halogen lamp or infrared heater, avoid irradiating the surface of the PWB directly.