



ER300~ER308

SUPERFAST RECOVERY RECTIFIERS

VOLTAGE 50 to 800 Volts CURRENT 3.0 Ampere

FEATURES

- Superfast recovery times-epitaxial construction.
- Low forward voltage, high current capability.
- Exceeds environmental standards of MIL-S-19500/228.
- Hermetically sealed.
- Low leakage.
- High surge capability.
- Plastic package has Underwriters Laboratories Flammability Classification 94V-O utilizing Flame Retardant Epoxy Molding Compound.
- In compliance with EU RoHS 2002/95/EC directives

MECHANICAL DATA

- Case: Molded plastic, DO-201AD
- Terminals: Axial leads, solderable to MIL-STD-750, Method 2026
- Polarity: Color Band denotes cathode end
- Mounting Position: Any
- Weight: 0.0395 ounce, 1.122 gram

DO-201AD

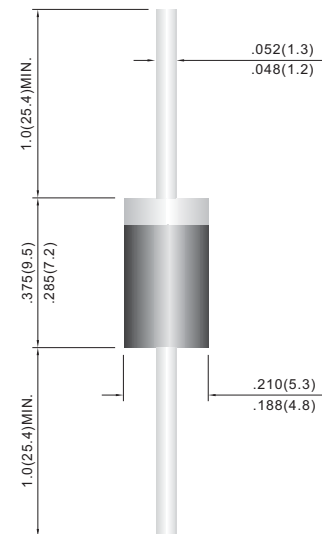

Unit:inch(mm)

MAXIMUM RATINGS AND ELECTRICAL CHARACTERISTICS

Ratings at 25°C ambient temperature unless otherwise specified.

Resistive or inductive load, 60Hz.

| PARAMETER | SYMBOL | ER300 | ER301 | ER301A | ER302 | ER303 | ER304 | ER306 | ER306A | ER308 | UNITS |
|--|-----------------|-------|-------|--------|-------|-------------|-------|-------|--------|-------|-----------------|
| Maximum Recurrent Peak Reverse Voltage | V_{RRM} | 50 | 100 | 150 | 200 | 300 | 400 | 600 | 700 | 800 | V |
| Maximum RMS Voltage | V_{RMS} | 35 | 70 | 105 | 140 | 210 | 280 | 420 | 490 | 560 | V |
| Maximum DC Blocking Voltage | V_{DC} | 50 | 100 | 150 | 200 | 300 | 400 | 600 | 700 | 800 | V |
| Maximum Average Forward Current .375"(9.5mm) lead length at $T_A=55^{\circ}C$ | $I_{F(AV)}$ | 3.0 | | | | | | | | | A |
| Peak Forward Surge Current :8.3ms single half sine-wave superimposed on rated load(JEDEC method) | I_{FSM} | 125 | | | | | | | | | A |
| Maximum Forward Voltage at 3.0A DC | V_F | 0.95 | | | 1.25 | | 1.70 | 2.0 | 2.5 | | V |
| Maximum DC Reverse Current at $T_J=25^{\circ}C$ Rated DC Blocking Voltage $T_J=125^{\circ}C$ | I_R | | | | | 1.0 | 300 | | | | μA |
| Maximum Reverse Recovery Time(Note 1) | t_{rr} | | | | | 35 | | | | | ns |
| Typical Junction capacitance (Note 2) | C_J | | | | | 35 | | | | | pF |
| Typical Junction Resistance(Note 3) | $R_{\theta JA}$ | | | | | 20 | | | | | $^{\circ}C / W$ |
| Operating and Storage Temperature Range | T_J, T_{STG} | | | | | -55 to +150 | | | | | $^{\circ}C$ |

NOTES:1. Reverse Recovery Test Conditions: $I_F=.5A, I_R=1A, I_{rr}=.25A$

2. Measured at 1 MHz and applied reverse voltage of 4.0 VDC

3. Thermal resistance from junction to ambient and from junction to lead length 0.375"(9.5mm) P.C.B. mounted





RATING AND CHARACTERISTIC CURVES

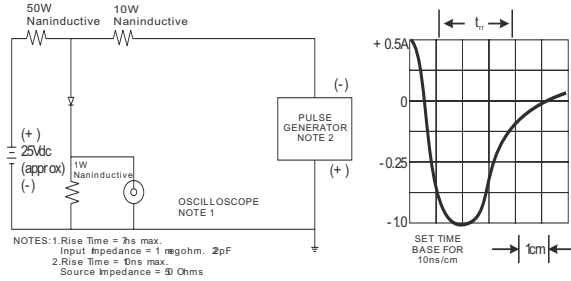

FIG.1 REVERSE RECOVERY TIME CHARACTERISTIC AND TEST CIRCUIT DIAGRAM

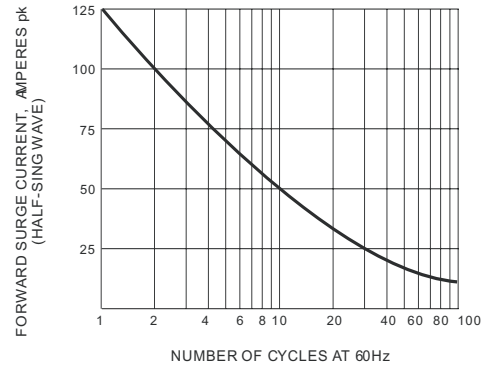

FIG.2 MAXIMUM NON-REPEITIVE SURGE CURRENT

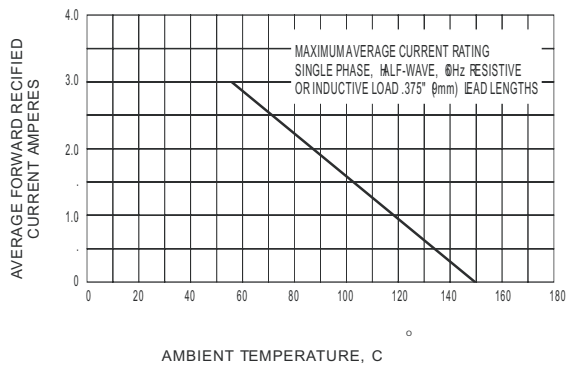

FIG.3 MAXIMUM AVERAGE FORWARD CURRENT RATING

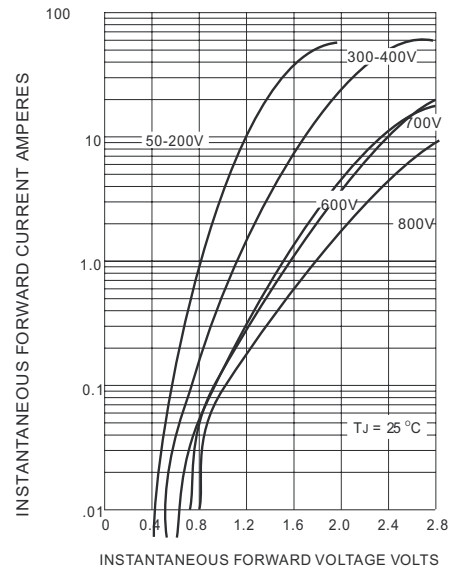

FIG.4 TYPICAL JUNCTION CAPACITANCE

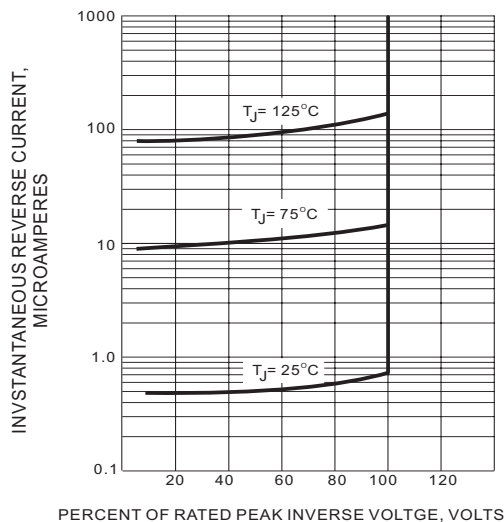

FIG.5 TYPICAL REVERSE CHARACTERISTICS

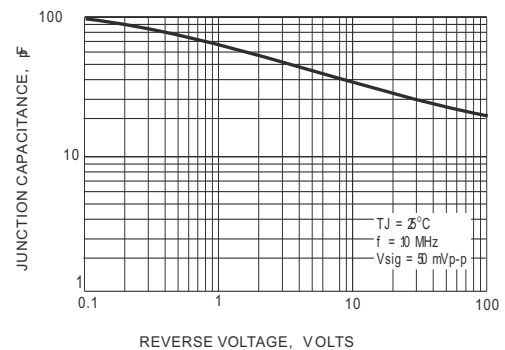

FIG.6 TYPICAL JUNCTION CAPACITANCE