

ERL35 SERIES POWER TRANSFORMER MODULES

PRODUCT OVERVIEW: THT POWER TRANSFORMERS

Characteristics

High insulation type High efficiency
 IEC60950 Compatible
 Operating temperature range: -40°C to +85°C

Applications

Lighting
 metering
 industrial Controls
 Stand-by Power
 White Goods
 Telecom
 DC/DC Converter



Bobbin Winding Area

Width (mm)	Build (mm)	Perimeter (mm)
27.2	5.69	47.8

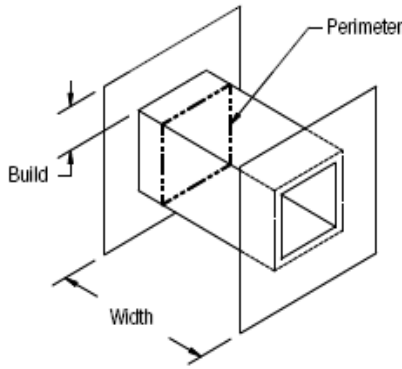

CORE DATA

Ae (mm ²)	Ve (mm ³)	Le (mm)
107	9972.4	93.2

POWER LEVEL (W)

Flyback	Forward	Push-pull
167	250	501

Test frequency: 100KHz

THT Horizontal

Dimensions & Footprint

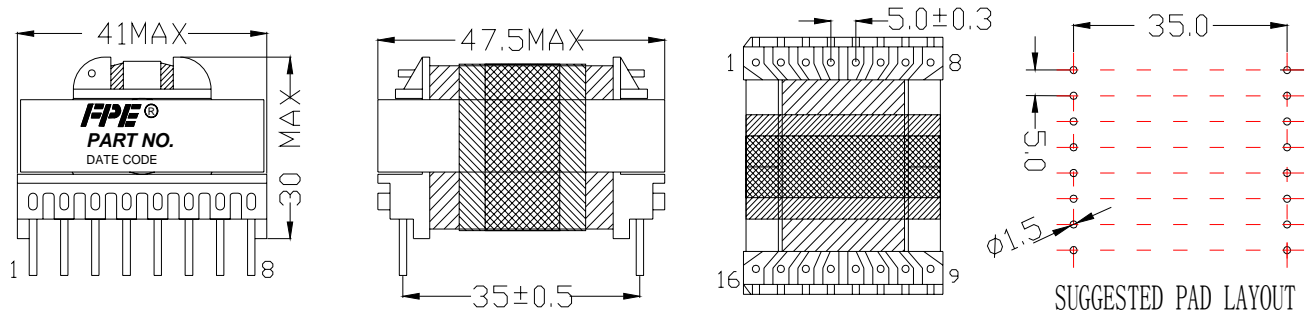

THT Vertical

Dimensions & Footprint

