

10 Series

■ Ratings and Characteristics

● Operating Temperature Range : -40 to 85 °C

● Storage Temperature Range : -40 to 125 °C

ERZV10D180 to ERZV10D680

Part No.	Varistor Voltage	Maximum Allowable Voltage		Clamping Voltage (max.)	Rated Power	Maximum Energy		Maximum Peak Current (8/20 μs)		Capacitance (max.) @1 kHz (pF)
						(10/1000 μs)	(2 ms)	1 time	2 times	
	V _{1 mA} (V)	ACrms (V)	DC (V)	V _{25 A} (V)	(W)	(J)	(J)	(A)	(A)	
ERZV10D180	18 (16-20)	11	14	36	0.05	2.6	2.2	1000	500	16000
ERZV10D220	22 (20-24)	14	18	43	0.05	3.2	2.6	1000	500	11000
ERZV10D270	27 (24-30)	17	22	53	0.05	3.9	3.2	1000	500	8000
ERZV10D330	33 (30-36)	20	26	65	0.05	4.8	4.0	1000	500	6300
ERZV10D390	39 (35-43)	25	31	77	0.05	5.6	4.7	1000	500	5200
ERZV10D470	47 (42-52)	30	38	93	0.05	6.8	5.6	1000	500	4600
ERZV10D560	56 (50-62)	35	45	110	0.05	8.1	6.7	1000	500	3750
ERZV10D680	68 (61-75)	40	56	135	0.05	9.8	8.2	1000	500	2800

ERZV10D820 to ERZV10D182CS

Part No.	Varistor Voltage	Maximum Allowable Voltage		Clamping Voltage (max.)	Rated Power	Maximum Energy		Maximum Peak Current (8/20 μs)		Capacitance (max.) @1 kHz (pF)
						(10/1000 μs)	(2 ms)	1 time	2 times	
	V _{1 mA} (V)	ACrms (V)	DC (V)	V _{25 A} (V)	(W)	(J)	(J)	(A)	(A)	
ERZV10D820	82(74- 90)	50	65	135	0.4	14	10	3500	2500	2000
ERZV10D101	100(90- 110)	60	85	165	0.4	17	12	3500	2500	1700
ERZV10D121	120(108- 132)	75	100	200	0.4	20	14.5	3500	2500	1400
ERZV10D151	150(135- 165)	95	125	250	0.4	25	18	3500	2500	1100
ERZV10D201	200(185- 225)	130	170	340	0.4	35	25	3500	2500	430
ERZV10D221	220(198- 242)	140	180	360	0.4	39	27.5	3500	2500	410
ERZV10D241	240(216- 264)	150	200	395	0.4	42	30	3500	2500	380
ERZV10D271	270(247- 303)	175	225	455	0.4	49	35	3500	2500	350
ERZV10D331	330(297- 363)	210	270	545	0.4	58	42	3500	2500	300
ERZV10D361	360(324- 396)	230	300	595	0.4	65	45	3500	2500	300
ERZV10D391	390(351- 429)	250	320	650	0.4	70	50	3500	2500	300
ERZV10D431	430(387- 473)	275	350	710	0.4	80	55	3500	2500	270
ERZV10D471	470(423- 517)	300	385	775	0.4	85	60	3500	2500	230
ERZV10D511	510(459- 561)	320	410	845	0.4	92	67	3500	2500	210
ERZV10D621	620(558- 682)	385	505	1025	0.4	92	67	3500	2500	190
ERZV10D681	680(612- 748)	420	560	1120	0.4	92	67	3500	2500	170
ERZV10D751	750(675- 825)	460	615	1240	0.4	100	70	3500	2500	160
ERZV10D821	820(738- 902)	510	670	1355	0.4	110	80	3500	2500	140
ERZV10D911	910(819-1001)	550	745	1500	0.4	130	90	3500	2500	120
ERZV10D102	1000(900-1100)	625	825	1650	0.4	140	100	3500	2500	110
ERZV10D112	1100(990-1210)	680	895	1815	0.4	155	110	3500	2500	110
ERZV10D182CS	1800(1700-1980)	1000	1465	2970	0.4	247	183	3500	2500	70*

* Measured at 1 MHz

■ Dimensions in mm (not to scale) * Refer to page 100 to 101 about leads cut type and taping.

ERZV10D180 to ERZV10D680

Part No.	D max.	T max.	W	H max.	L
ERZV10D180	11.5	4.6	7.5±1.0	14.5	1.3±1.0
ERZV10D220	11.5	4.7	7.5±1.0	14.5	1.4±1.0
ERZV10D270	11.5	4.8	7.5±1.0	14.5	1.5±1.0
ERZV10D330	11.5	5.0	7.5±1.0	14.5	1.7±1.0
ERZV10D390	11.5	4.9	7.5±1.0	14.5	1.6±1.0
ERZV10D470	11.5	5.0	7.5±1.0	14.5	1.7±1.0
ERZV10D560	11.5	5.1	7.5±1.0	14.5	1.8±1.0
ERZV10D680	11.5	5.3	7.5±1.0	14.5	2.0±1.0

ERZV10D820 to ERZV10D182CS

Part No.	D max.	T max.	W	H max.	L
ERZV10D820	11.5	4.5	7.5±1.0	14.5	1.6±1.0
ERZV10D101	11.5	4.7	7.5±1.0	14.5	1.8±1.0
ERZV10D121	11.5	4.9	7.5±1.0	14.5	2.0±1.0
ERZV10D151	11.5	5.2	7.5±1.0	14.5	2.3±1.0
ERZV10D201	11.5	4.8	7.5±1.0	14.5	1.9±1.0
ERZV10D221	11.5	4.9	7.5±1.0	14.5	2.0±1.0
ERZV10D241	11.5	5.0	7.5±1.0	14.5	2.1±1.0
ERZV10D271	11.5	5.2	7.5±1.0	14.5	2.3±1.0
ERZV10D331	11.5	5.5	7.5±1.0	14.5	2.6±1.0
ERZV10D361	11.5	5.7	7.5±1.0	14.5	2.8±1.0
ERZV10D391	11.5	5.8	7.5±1.0	14.5	2.9±1.0
ERZV10D431	11.5	6.0	7.5±1.0	14.5	3.1±1.0
ERZV10D471	11.5	6.2	7.5±1.0	14.5	3.3±1.0
ERZV10D511	11.5	6.4	7.5±1.0	14.5	3.5±1.0
ERZV10D621	12.5	7.1	7.5±1.0	15.5	4.2±1.0
ERZV10D681	12.5	7.4	7.5±1.0	15.5	4.5±1.0
ERZV10D751	12.5	7.8	7.5±1.0	15.5	4.9±1.0
ERZV10D821	12.5	8.1	7.5±1.0	15.5	5.2±1.0
ERZV10D911	12.5	8.6	7.5±1.0	15.5	5.7±1.0
ERZV10D102	12.5	9.1	7.5±1.0	15.5	6.2±1.0
ERZV10D112	12.5	9.7	7.5±1.0	15.5	6.8±1.0
ERZV10D182CS	13.5	14.4	11.0±1.0*	16.5	10.0±1.5

*: W₂

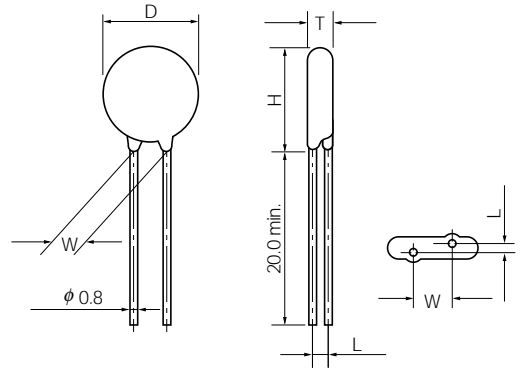

(ERZV10D182CS)

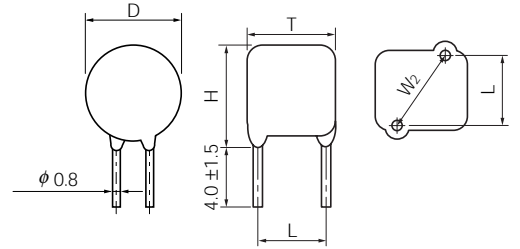

■ Typical Characteristics

Voltage vs. Current

ERZV10D180 to ERZV10D680

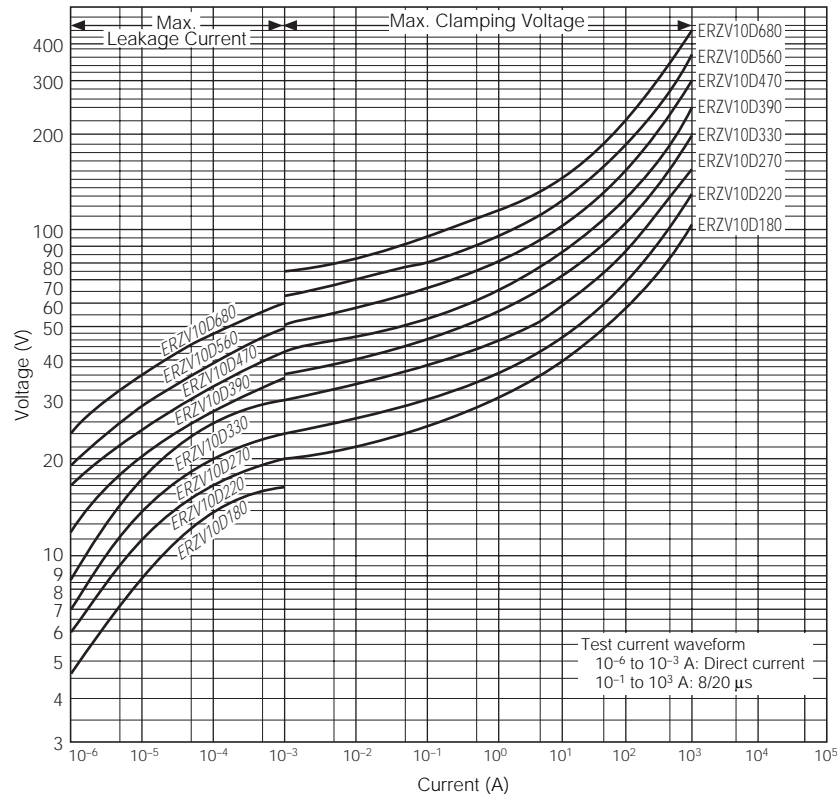

Impulse Derating (Relation between impulse width and impulse current multiple)

ERZV10D180 to ERZV10D680

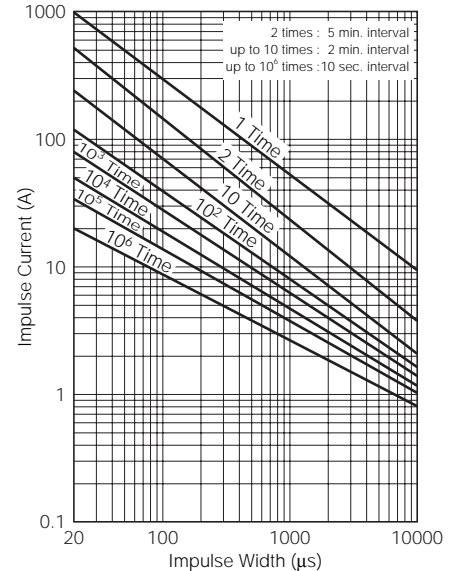

■ Typical Characteristics
Voltage vs. Current

ERZV10D820 to ERZV10D511

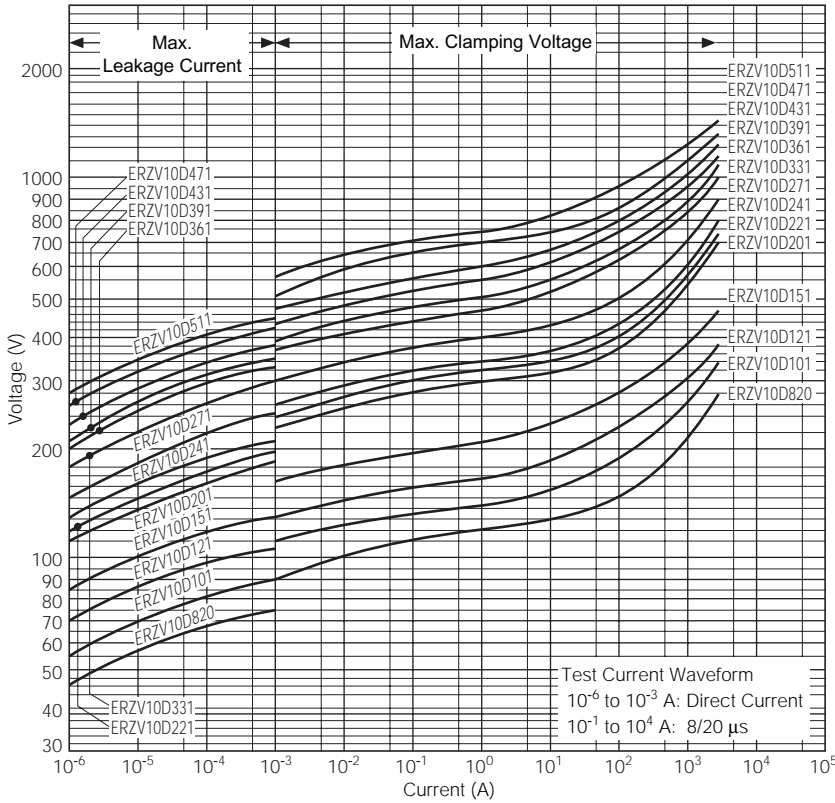

Impulse Derating (Relation between impulse width and impulse current multiple)

ERZV10D820 to ERZV10D511

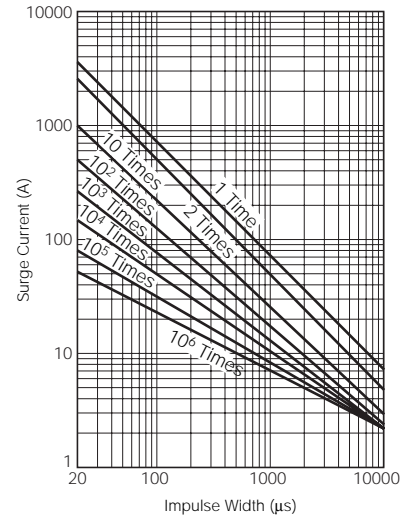

ERZV10D621 to ERZV10D112

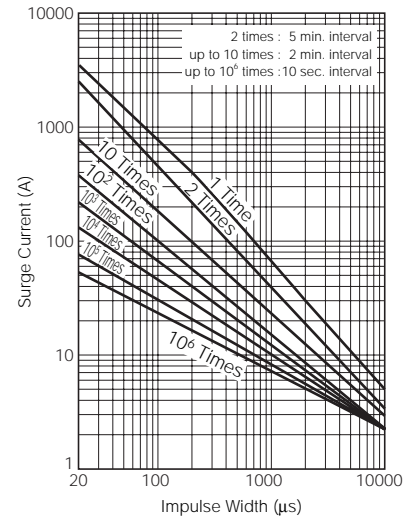

ERZV10D621 to ERZV10D182CS

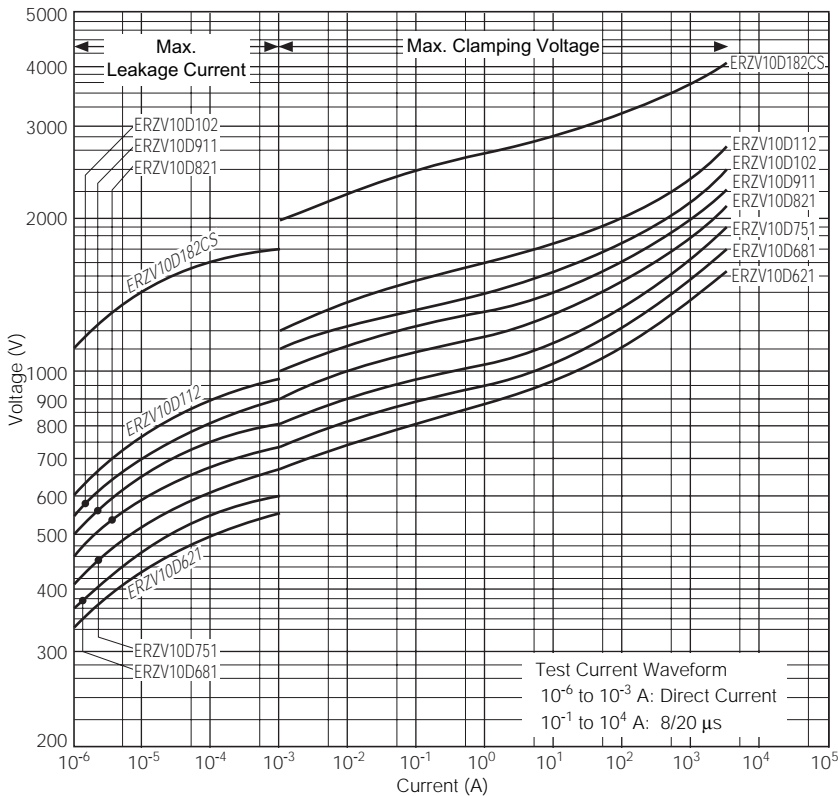

ERZV10D182CS

