

Super Fast Surface Mount Rectifiers
 Reverse Voltage 50V to 1000V Forward Current 1.0A

ES1A thru ES1M

Features

- For surface mounted application
- Low profile package
- Built-in strain relief, ideal for automatic placement
- Easy pick and place
- Super fast recovery time for high efficiency
- Glass passivated junction chip
- High temperature soldering: 250° C/10 seconds at terminals
- Plastic material used carries UL flammability classification 94V-0

Mechanical Data

- Case: SMA/DO-214AC molded plastic
- Terminals: Pure tin plated, solderable per MIL-STD-750 method 2026
- Polarity: Indicated by cathode band
- Weight: 0.064 gram, 0.002 ounce

Outline



Ordering Information

Device	Package	Shipping	Marking
ES1A-0-T4-G	SMA (Pb-free lead plating and halogen-free package)	7500 pcs / Tape & Reel	ES1A
ES1B-0-T4-G			ES1B
ES1C-0-T4-G			ES1C
ES1D-0-T4-G			ES1D
ES1F-0-T4-G			ES1F
ES1G-0-T4-G			ES1G
ES1J-0-T4-G			ES1J
ES1K-0-T4-G			ES1K
ES1M-0-T4-G			ES1M

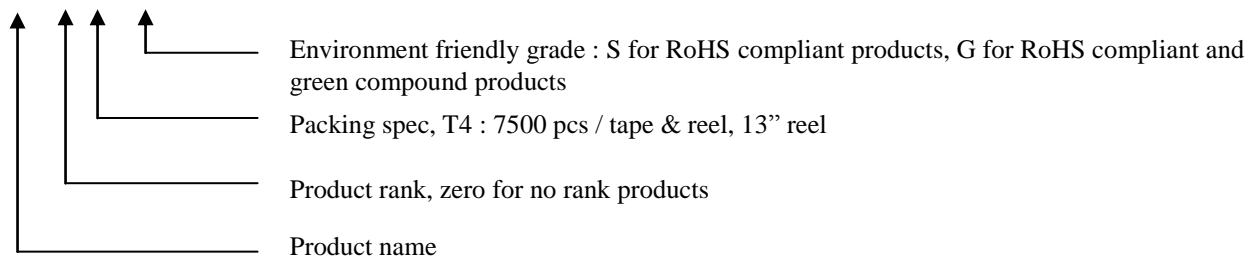

Maximum Ratings and Electrical Characteristics

(Rating at 25°C ambient temperature unless otherwise specified. Single phase, half wave, 60Hz, resistive or inductive load. For capacitive load, derate current by 20%.)

Parameter	Symbol	Type									Units
		ES1A	ES1B	ES1C	ES1D	ES1F	ES1G	ES1J	ES1K	ES1M	
Maximum repetitive peak reverse voltage	V_{RRM}	50	100	150	200	300	400	600	800	1000	V
Maximum RMS voltage	V_{RMS}	35	70	105	140	210	280	420	560	700	V
Maximum DC blocking voltage	V_R	50	100	150	200	300	400	600	800	1000	V
Maximum instantaneous forward voltage, $I_F=1A$	V_F	0.95			1.3		1.7		2.5		V
Maximum average forward rectified current, see Fig. 1	$I_{F(AV)}$	1									A
Peak forward surge current @8.3ms single half sine wave superimposed on rated load (JEDEC method)	I_{FSM}	30									A
Maximum DC reverse current $V_R=V_{RRM}, T_A=25^\circ C$ $V_R=V_{RRM}, T_A=100^\circ C$	I_R	5 100									μA
Maximum reverse recovery time (Note 1)	t_{rr}	35									ns
Typical junction capacitance @ f=1MHz and applied 4V reverse voltage	C_J	10				8					pF
Typical thermal resistance (Note 2)	$R_{\theta JA}$	85									$^\circ C/W$
	$R_{\theta JC}$	40									
Power dissipation	$T_A=25^\circ C$ (Note 2)	1.5									W
	$T_C=25^\circ C$	3.1									
Storage temperature range	T_{STG}	-55 ~ +150									$^\circ C$
Operating junction temperature range	T_J	-55 ~ +150									$^\circ C$

Note: 1.Reverse recovery test conditions : $I_F=0.5A$, $I_R=1A$, $I_{RR}=0.25A$

2.P.C.B. mounted on 0.2"×0.2"(5.0mm×5.0mm) copper pad area.

Recommended soldering footprint

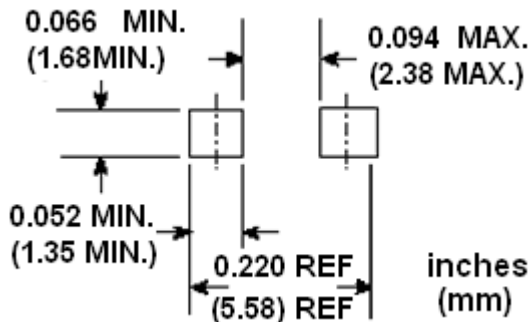

Characteristic Curves

FIG.1- MAXIMUM FORWARD CURRENT DERATING CURVE

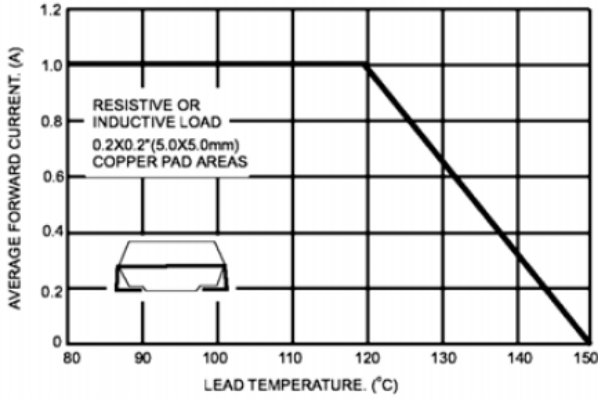

FIG.2- MAXIMUM NON-REPETITIVE PEAK FORWARD SURGE CURRENT

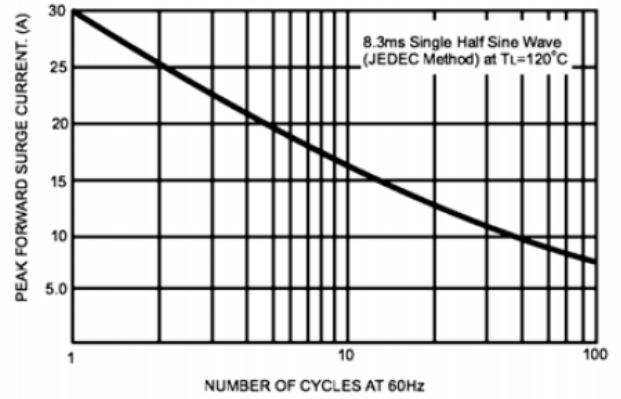

FIG.3- TYPICAL INSTANTANEOUS FORWARD CHARACTERISTICS

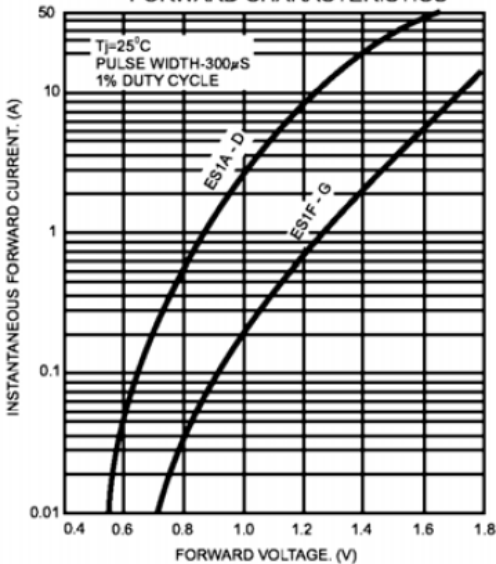

FIG.4- TYPICAL REVERSE CHARACTERISTICS

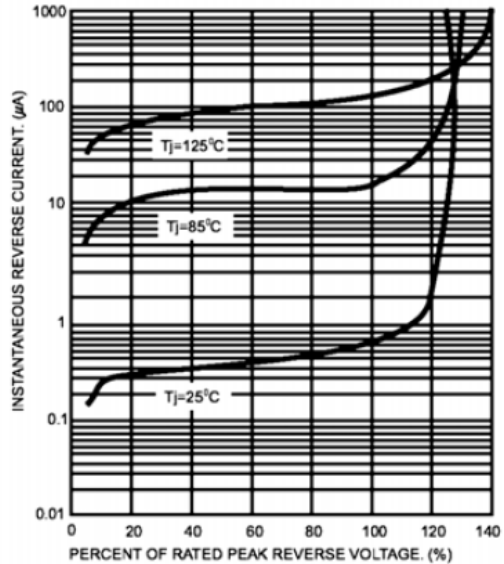
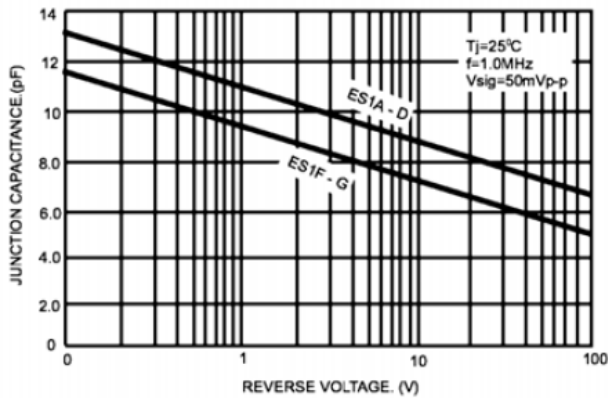
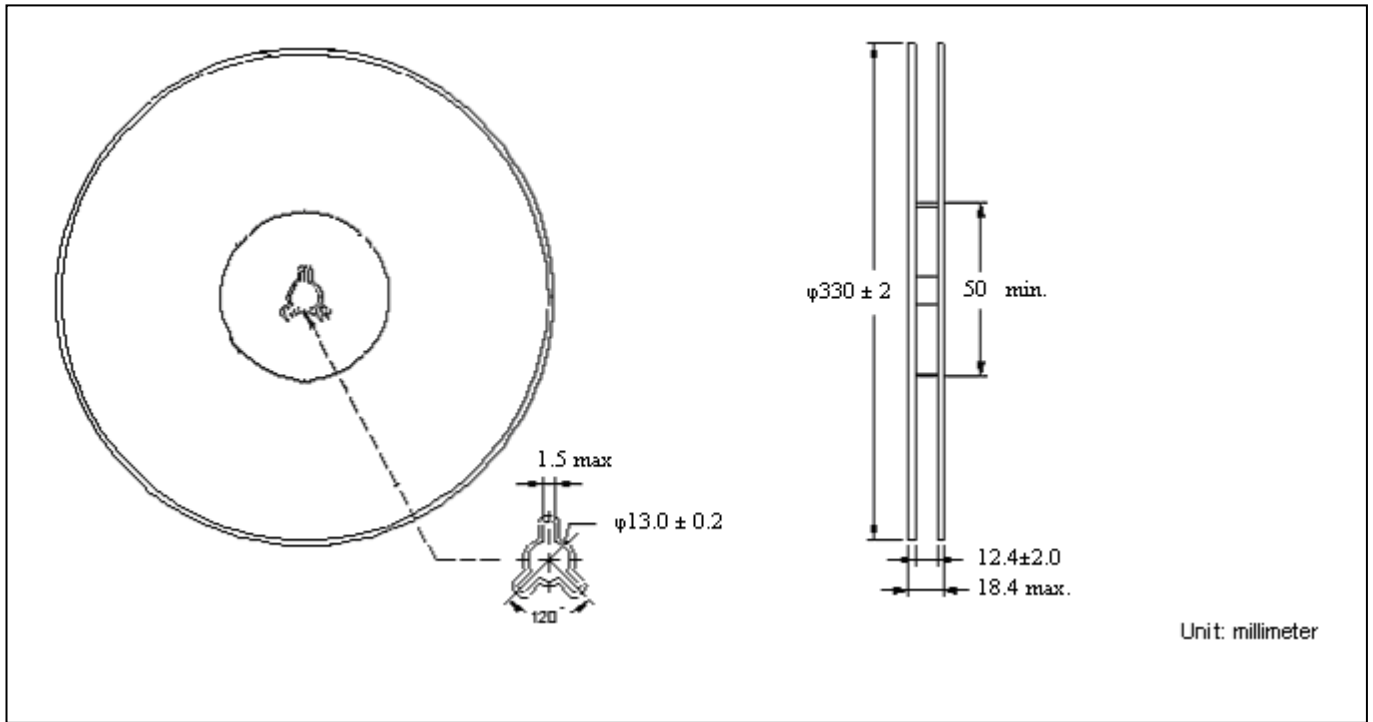

FIG.5- TYPICAL JUNCTION CAPACITANCE



Reel Dimension



Carrier Tape Dimension

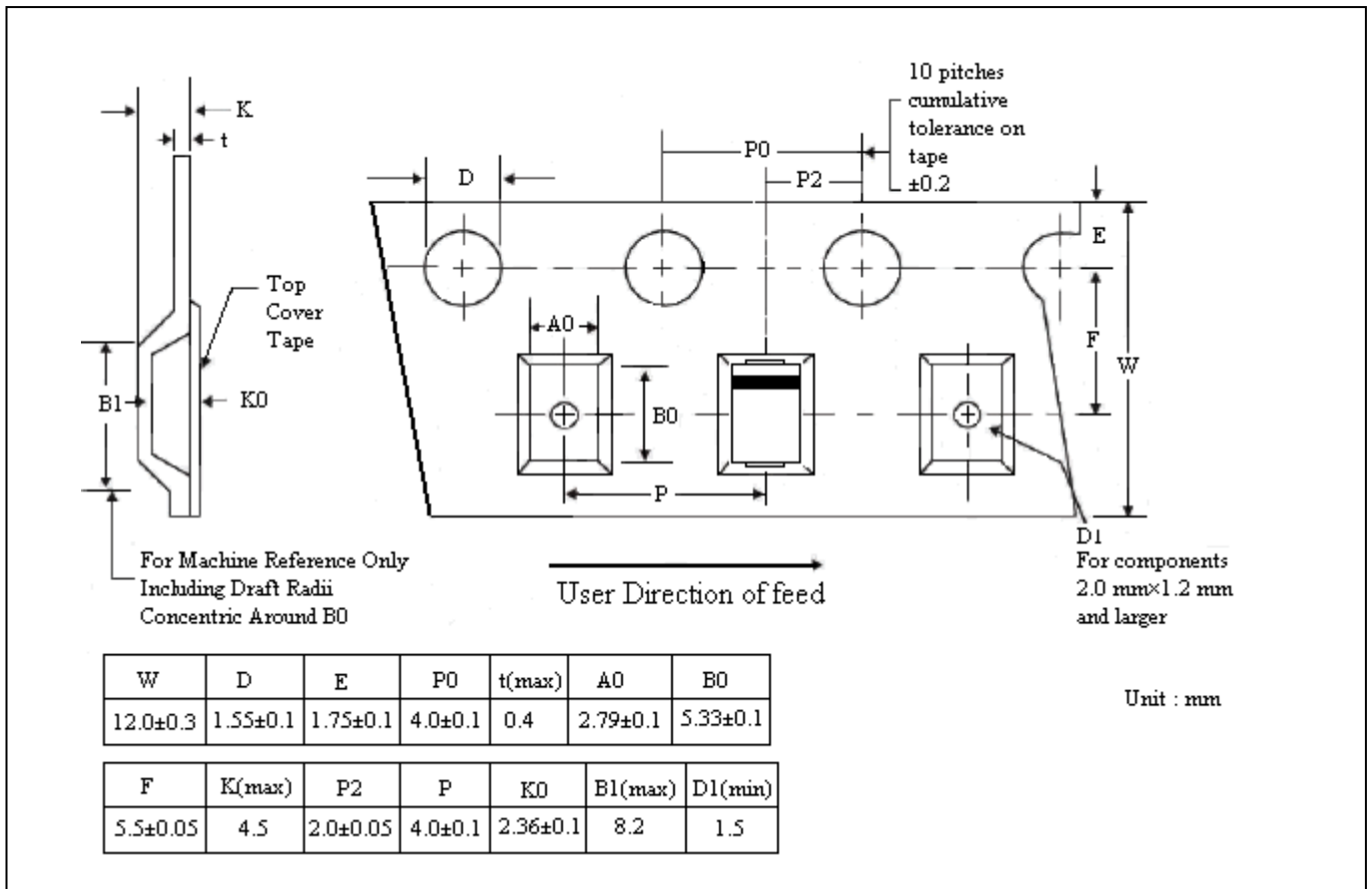

Recommended wave soldering condition

Product	Peak Temperature	Soldering Time
Pb-free devices	260 +0/-5 °C	5 +1/-1 seconds

Recommended temperature profile for IR reflow

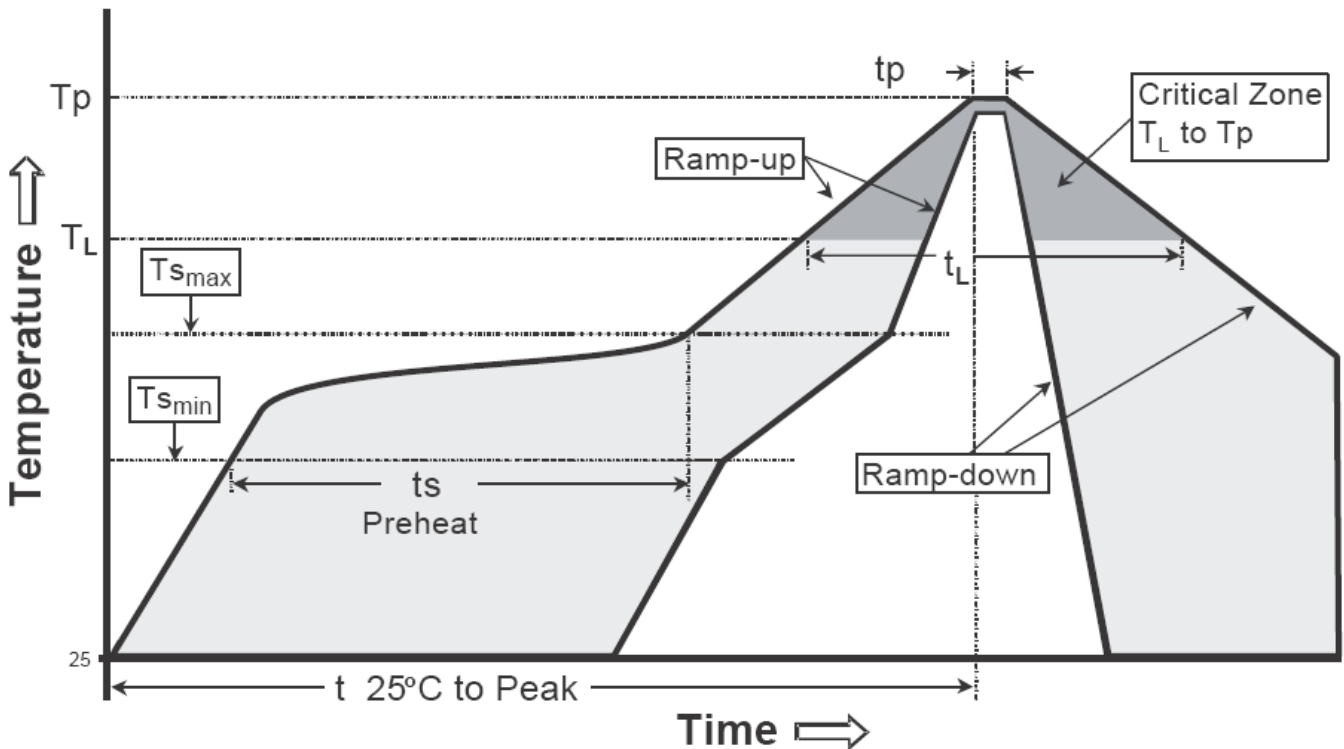

Profile feature	Sn-Pb eutectic Assembly	Pb-free Assembly
Average ramp-up rate (Tsmax to Tp)	3°C/second max.	3°C/second max.
Preheat		
-Temperature Min(Ts min)	100°C	150°C
-Temperature Max(Ts max)	150°C	200°C
-Time(ts min to ts max)	60-120 seconds	60-180 seconds
Time maintained above:		
-Temperature (Tl)	183°C	217°C
- Time (tl)	60-150 seconds	60-150 seconds
Peak Temperature(Tp)	240 +0/-5 °C	260 +0/-5 °C
Time within 5°C of actual peak temperature(tp)	10-30 seconds	20-40 seconds
Ramp down rate	6°C/second max.	6°C/second max.
Time 25 °C to peak temperature	6 minutes max.	8 minutes max.

Note : All temperatures refer to topside of the package, measured on the package body surface.

SMA/DO-214AC Dimension

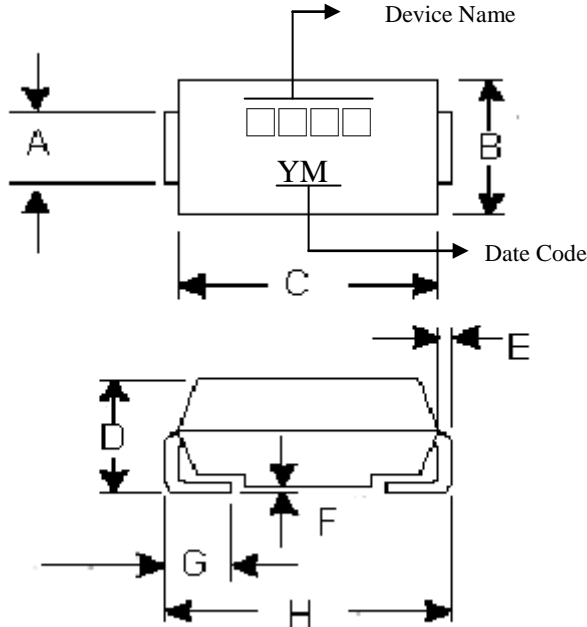

Marking :

Device	ES1A	ES1B	ES1C
Code	ES1A	ES1B	ES1C
Device	ES1D	ES1F	ES1G
Code	ES1D	ES1F	ES1G
Device	ES1J	ES1K	ES1M
Code	ES1J	ES1K	ES1M

SMA/DO-214AC Plastic
 Surface Mounted Package
 CYStek Package Code : SA

Date Code : Year Code + Month Code

Year Code :

Year	2009	2010	2011	2012	2013	2014	2015	2016	2017	2018	2019	2020	2021
Code	9	A	B	C	D	E	F	G	H	J	K	0	1

Month Code :

Month	Jan	Feb	Mar	Apr	May	Jun	Jul	Aug	Sep	Oct	Nov	Dec
Code	1	2	3	4	5	6	7	8	9	O	N	D

DIM	Inches		Millimeters		DIM	Inches		Millimeters	
	Min.	Max.	Min.	Max.		Min.	Max.	Min.	Max.
A	0.052	0.062	1.32	1.60	E	0.006	0.012	0.15	0.31
B	0.098	0.114	2.50	2.90	F	0.002	0.008	0.05	0.20
C	0.154	0.181	3.90	4.60	G	0.030	0.060	0.76	1.52
D	0.067	0.091	1.70	2.30	H	0.188	0.208	4.80	5.28

- Notes : 1.Controlling dimension : millimeters.
 2.Maximum lead thickness includes lead finish thickness, and minimum lead thickness is the minimum thickness of base material.
 3.If there is any question with packing specification or packing method, please contact your local CYStek sales office.

Material :

- Lead : Pure tin plated.
- Mold Compound : Epoxy resin family, flammability solid burning class:UL94V-0.

Important Notice:

- All rights are reserved. Reproduction in whole or in part is prohibited without the prior written approval of CYStek.
- CYStek reserves the right to make changes to its products without notice.
- CYStek **semiconductor products are not warranted to be suitable for use in Life-Support Applications, or systems.**
- CYStek assumes no liability for any consequence of customer product design, infringement of patents, or application assistance.