

# Super-Fast Rectifiers

## ES1E--ES1G

### Features

- For surface mounted applications
- Ideal for automated placement
- Low forward voltage drop
- High surge current capability
- RoHS Compliant



### Mechanical Data

- Case: SMA molded plastic
- Molding compound, UL flammability classification rating 94V-0
- Terminals: Solder plated, solderable per MIL- STD-202, Method 208
- Polarity: Color band denotes cathode end

### Maximum Ratings (@T<sub>A</sub> = 25°C unless otherwise specified)

Characteristic	Symbol	ES1E	ES1G	Units
Peak repetitive reverse voltage	V <sub>RRM</sub>	300	400	V
RMS reverse voltage	V <sub>RMS</sub>	210	280	V
DC blocking voltage	V <sub>DC</sub>	300	400	V
Maximum average forward output current	I <sub>F(AV)</sub>	1.0		A
Peak forward surge current, 8.3ms single half-sine-wave	I <sub>FSM</sub>	30		A

### Thermal Characteristics

Parameter	Symbol	ES1E	ES1G	Units
Typical thermal resistance (Note 1)	R <sub>θJA</sub>	70		°C/W
	R <sub>θJC</sub>	25		
	R <sub>θJL</sub>	30		
Operating junction temperature range	T <sub>J</sub>	- 55 ---- + 150		°C
Storage temperature range	T <sub>STG</sub>	- 55 ---- + 150		°C

Note:

1. Device mounted on PCB with 10 mm x 20 mm x 0.1mm copper pad areas

## Super-Fast Rectifiers

## ES1E--ES1G

### Electrical Characteristics (@ $T_A = 25^\circ\text{C}$ unless otherwise specified)

Parameter	Symbol	Test conditions		Typ.	Max.	Units
Maximum instantaneous forward voltage	$V_F$	$I_F=1.0\text{A}$	@ $T_A=25^\circ\text{C}$	--	1.25	V
Maximum Reverse current	$I_R$	Rated $V_R$ ,	@ $T_A=25^\circ\text{C}$	--	5	$\mu\text{A}$
			@ $T_A=125^\circ\text{C}$	--	200	
Maximum Reverse Recovery Time	$t_{rr}$	$I_F=0.5\text{A}, I_{RM}=1\text{A}, I_{R(REC)}=0.25\text{A}$		--	35	ns

# Super-Fast Rectifiers

# ES1E--ES1G

## Ratings and Characteristic Curves ( $T_A=25^\circ\text{C}$ unless otherwise noted)

Fig.1-Forward Current Derating Curve

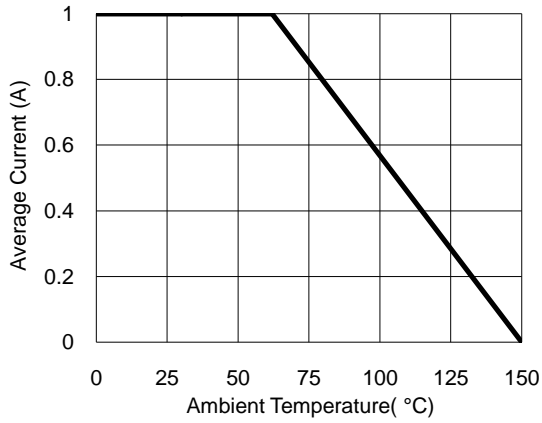

Fig.2- Surge Current Derating Curve

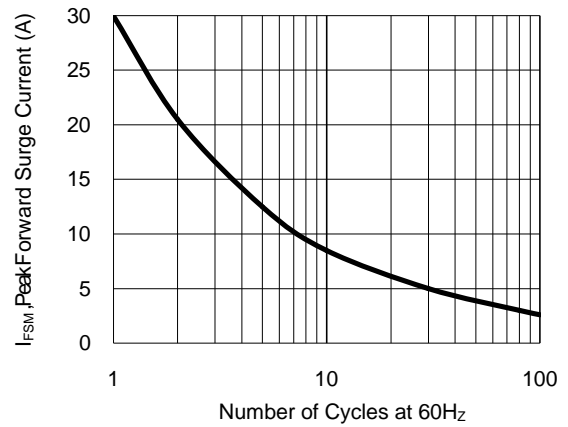

Fig.3- Typical Forward Voltage Characteristic

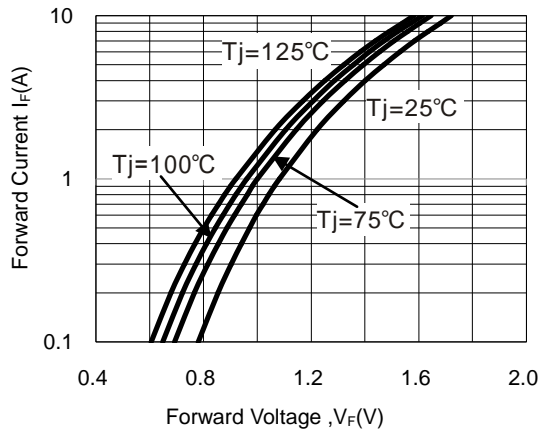
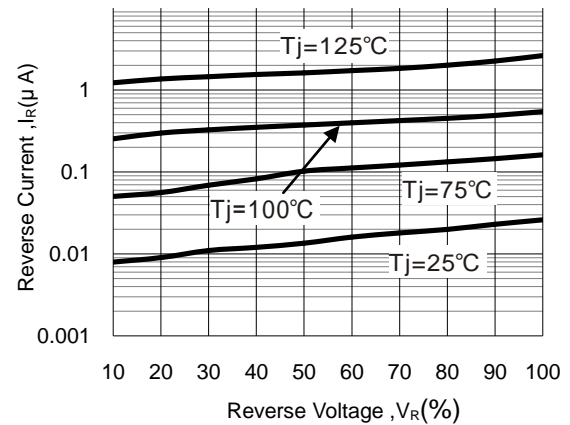

Fig.4- Typical Reverse Characteristic



## Super-Fast Rectifiers

ES1E--ES1G

### Package Outline Dimensions(unit:mm)

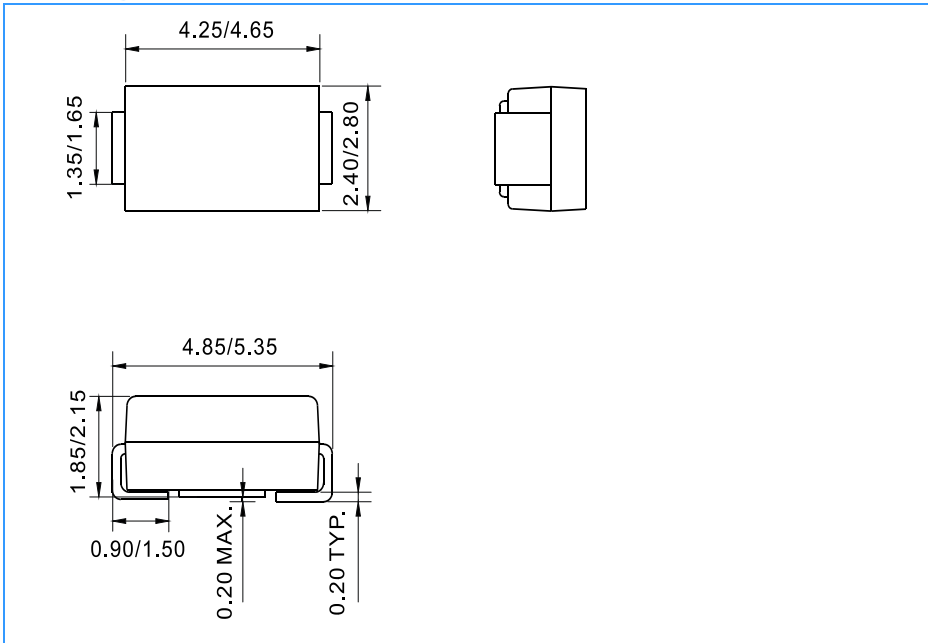

### Mounting Pad Layout(unit:mm)

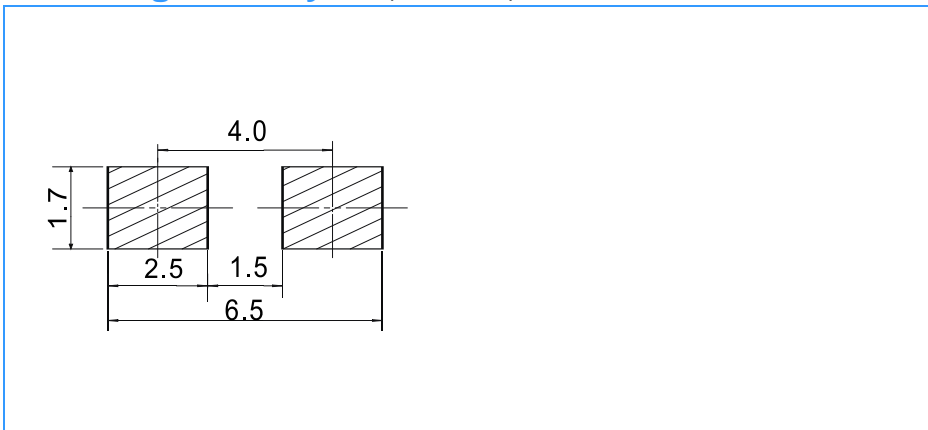

### Ordering Information

Part No.	Marking	Package	Shipping
ES1E	ES1E	SMA	5000 / Tape&Reel
ES1G	ES1G	SMA	5000 / Tape&Reel