

Super-Fast Rectifiers

ES1M

Features

- For surface mounted applications
- Ideal for automated placement
- Low forward voltage drop
- High surge current capability
- RoHS Compliant



Mechanical Data

- Case: SMA molded plastic
- Molding compound, UL flammability classification rating 94V-0
- Terminals: Solder plated, solderable per MIL-STD-202, Method 208
- Polarity: Color band denotes cathode end

Maximum Ratings (@T_A = 25°C unless otherwise specified)

Characteristic	Symbol	ES1M	Units
Peak repetitive reverse voltage	V _{RRM}	1000	V
RMS reverse voltage	V _{RMS}	700	V
DC blocking voltage	V _{DC}	1000	V
Maximum average forward output current	I _{F(AV)}	1.0	A
Peak forward surge current, 8.3ms single half-sine-wave	@T _J = 25°C I _{FSM}	30	A

Thermal Characteristics

Parameter	Symbol	ES1M	Units
Typical thermal resistance (Note 1)	R _{θJA}	70	°C /W
	R _{θJC}	25	
	R _{θJL}	30	
Operating junction temperature range	T _J	- 55 ---- + 150	°C
Storage temperature range	T _{STG}	- 55 ---- + 150	°C

Note:

1. Device mounted on PCB with 10 mm x 20 mm x 0.1mm copper pad areas

Super-Fast Rectifiers

ES1M

Electrical Characteristics (@T_A = 25°C unless otherwise specified)

Parameter	Symbol	Test conditions	Typ.	Max.	Units
Maximum instantaneous forward voltage	V _F	I _F =1.0A	--	2.5	V
Maximum Reverse current	I _R	Rated V _R	@T _A =25°C	10	μ A
			@T _A =125°C	200	
Maximum Reverse Recovery Time	t _{rr}	I _F =0.5A, I _{RM} =1A, I _{R(REC)} =0.25A	--	35	ns

Super-Fast Rectifiers

ES1M

Package Outline Dimensions(unit:mm)

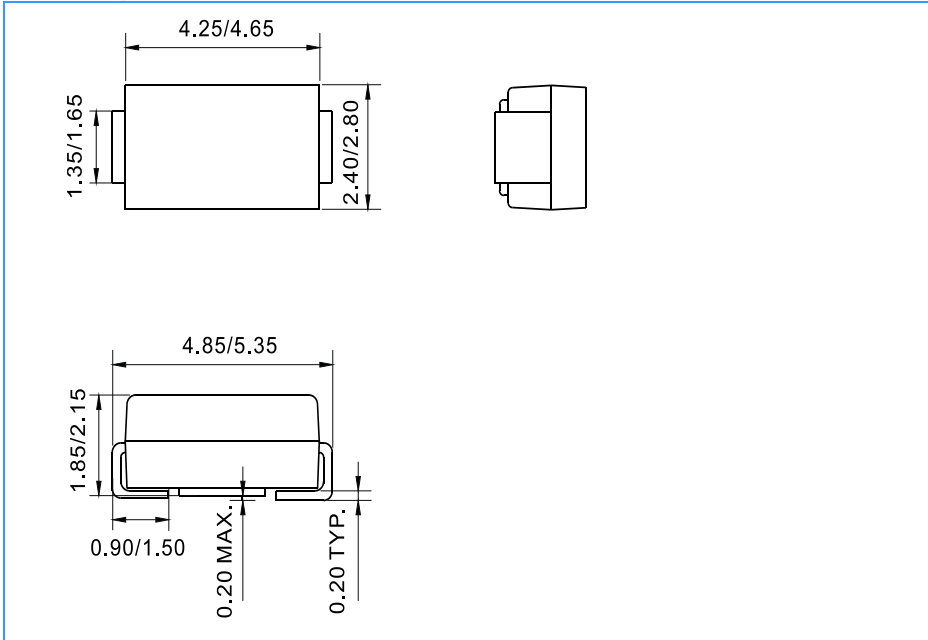

Mounting Pad Layout(unit:mm)

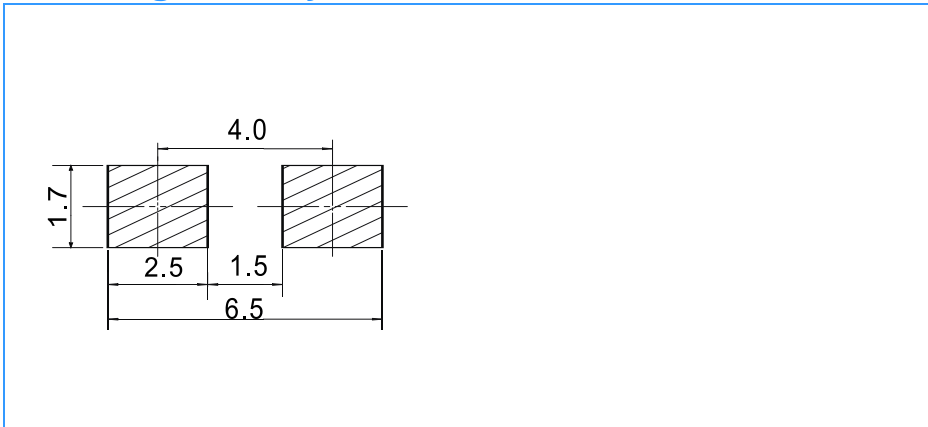

Ordering Information

Part No.	Marking	Package	Shipping
ES1M	ES1M	SMA	5000/Tape&Reel