



## SURFACE MOUNT SUPERFAST RECOVERY RECTIFIER

### ES2AF - ES2JF

VOLTAGE RANGE - 50 to 600 V  
CURRENT - 2 A

#### FEATURES

- For surface mounted applications
- Low profile package
- Glass Passivated Chip Junction
- Superfast reverse recovery time
- Lead free in comply with EU RoHS 2011/65/EU directives

#### MECHANICAL DATA

- Case: SMAF
- Terminals: Solderable per MIL-STD-750, Method 2026
- Approx. Weight: 27mg / 0.00095oz

#### PINNING

PIN	DESCRIPTION
1	Cathode
2	Anode

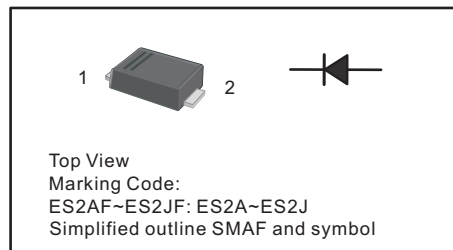

#### ABSOLUTE MAXIMUM RATINGS AND CHARACTERISTICS

Ratings at 25 °C ambient temperature unless otherwise specified. Single phase, half wave, 60 Hz, resistive or inductive load.

For capacitive load, derate current by 20%.

Parameter	Symbols	ES2AF	ES2BF	ES2CF	ES2DF	ES2EF	ES2GF	ES2JF	Units
Maximum Repetitive Peak Reverse Voltage	$V_{RRM}$	50	100	150	200	300	400	600	V
Maximum RMS voltage	$V_{RMS}$	35	70	105	140	210	280	420	V
Maximum DC Blocking Voltage	$V_{DC}$	50	100	150	200	300	400	600	V
Maximum Average Forward Rectified Current at $T_L = 100\text{ }^\circ\text{C}$	$I_{F(AV)}$	2							A
Peak Forward Surge Current 8.3 ms Single Half Sine Wave Superimposed on Rated Load (JEDEC Method)	$I_{FSM}$	50							A
Maximum Forward Voltage at 2A	$V_F$	1			1.25		1.68		V
Maximum DC Reverse Current at Rated DC Blocking Voltage $T_a = 25\text{ }^\circ\text{C}$ $T_a = 125\text{ }^\circ\text{C}$	$I_R$	5 100							$\mu\text{A}$
Typical Junction Capacitance at $V_R = 4\text{V}$ , $f = 1\text{MHz}$	$C_j$	45							pF
Maximum Reverse Recovery Time at $I_F = 0.5\text{A}$ , $I_R = 1\text{A}$ , $I_{rr} = 0.25\text{A}$	$t_{rr}$	35							ns
Typical Thermal Resistance <sup>2)</sup>	$R_{\theta JA}$	75							$^\circ\text{C/W}$
Operating and Storage Temperature Range	$T_j, T_{stg}$	-55 ~ +150							$^\circ\text{C}$

#### NOTE:

1) Measured with  $I_F = 0.5\text{A}$ ,  $I_R = 1\text{A}$ ,  $I_{rr} = 0.25\text{A}$

2) P.C.B. mounted with 0.5 X 0.5" (12.7 X 12.7 mm) copper pad areas.

**Fig.1 Reverse Recovery Time Characteristic And Test Circuit Diagram**

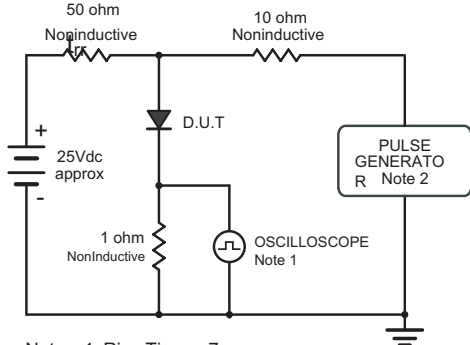

Note: 1. Rise Time = 7ns, max.  
Input Impedance = 1megohm, 22pF.  
2. Rise Time = 10ns,  
Source Impedance = 50 ohms.

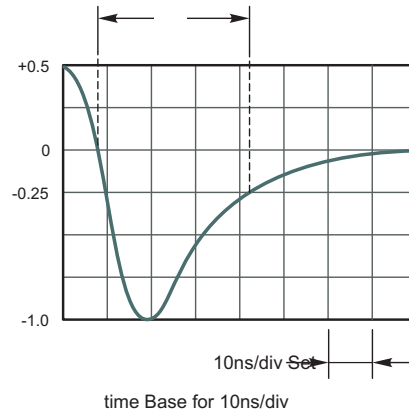

**Fig.2 Maximum Average Forward Current Rating**

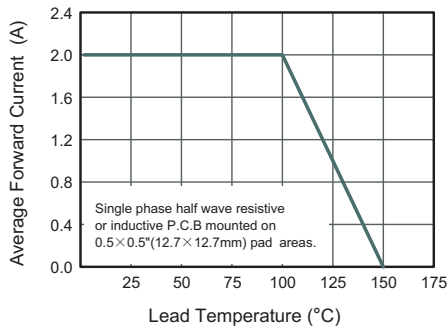

**Fig.3 Typical Reverse Characteristics**

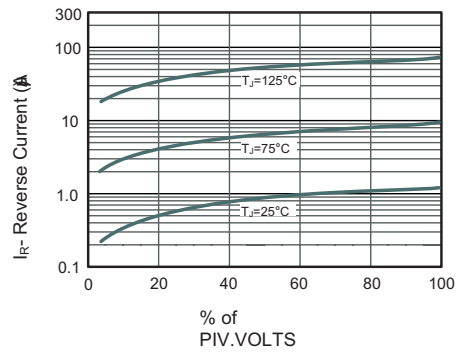

**Fig.4 Typical Forward Characteristics**

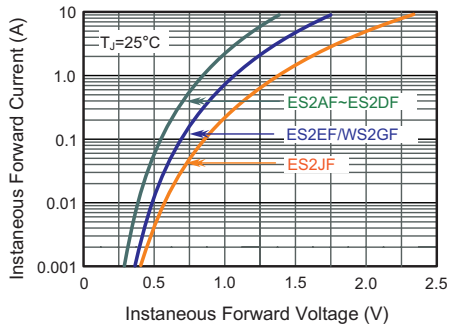

**Fig.5 Typical Junction Capacitance**

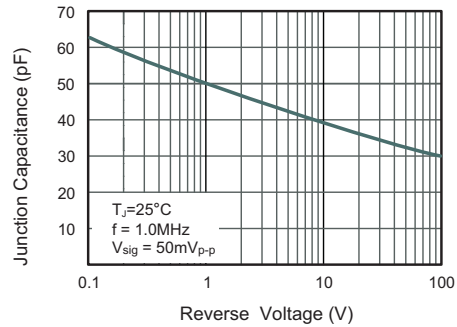

**Fig.6 Maximum Non-Repetitive Peak Forward Surge Current**

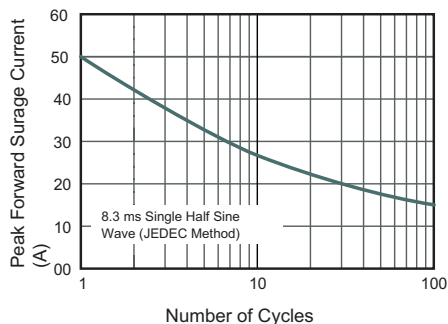



# SURFACE MOUNT SUPERFAST RECOVERY RECTIFIER

**ES2AF- ES2JF**

**VOLTAGE RANGE - 50 to 600 V**  
**CURRENT - 2 A**

## PACKAGE OUTLINE

PLASTIC SURFACE MOUNTED PACKAGE; 2 LEADS

SMAF

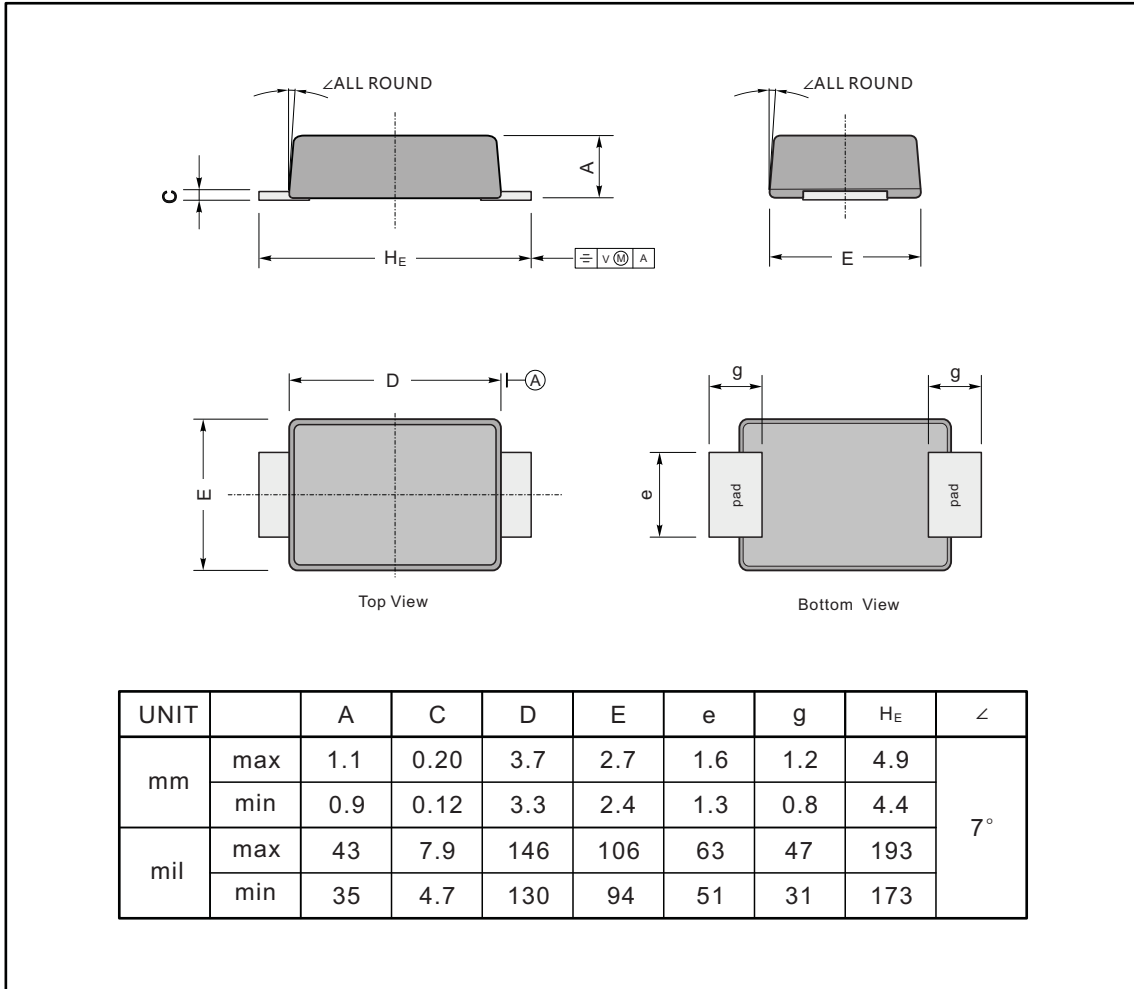

### The recommended mounting pad size

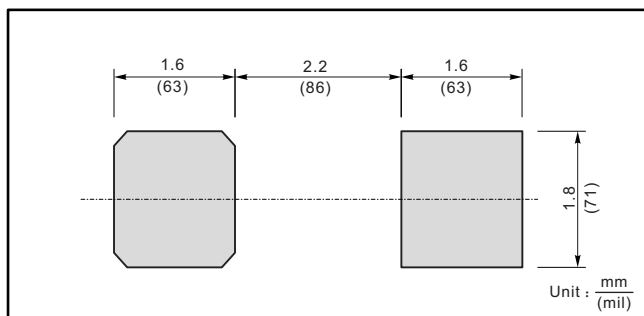

### Marking

Type number	Marking code
ES2AF	ES2A
ES2BF	ES2B
ES2CF	ES2C
ES2DF	ES2D
ES2EF	ES2E
ES2GF	ES2G
ES2JF	ES2J