



## DESCRIPTION

The Visba™ ES3883 video CD companion chip (CC) is the second-generation companion chip that provides an optimal system design for a video CD player when used with the Visba ES3880 video CD PC. The ES3883 Visba video CD CC integrates the CD-ROM controller (featuring direct servo control), as well as most of the required analog discrete components, into a simple, highly cost-effective design for a video CD player. The Visba video CD CC provides the best quality for both video and audio, and easily passes the highest graded level for the China VCD standard.

The Visba video CD CC features include a high-quality NTSC/PAL digital video encoder (DVE), echo, surround sound, audio DACs, and PLL clock synthesizer. Additionally, there are also three 9-bit video DACs and two 16-bit sigma-delta audio DACs. One video DAC handles composite video output, while the other two handle the S-video outputs. The two 16-bit sigma-delta audio DACs offer differential outputs. The differential dual audio outputs from these audio DACs ensure further noise reduction to a minimum of 90 dB, enabling the Visba video CD CC to pass the best quality audio on all video CD parameter specifications.

The DVE generates composite and S-video analog signals. Color space conversions (CSCs) are provided to match the input data to the required output format. Then, the data is filtered to meet the selected video standards. In addition, the Visba video CD CC is equipped with a remote control interface for power standby on/off, two microphone ports, auxiliary ports, and an interface for accessing internal registers.

The ES3883 is available in an industry-standard 100-pin plastic quad flat pack (PQFP) package.

## FEATURES

- Multistandard TV encoder:
  - CCIR601 nonsquare operation
  - NTSC/PAL formats
  - Master video mode
  - 8-bit interface for YCrCb (4:2:2) input format
  - Simultaneous composite and S-video output
  - Interlaced operation
- Audio DACs:
  - Two 16-bit sigma-delta DACs
  - Dual audio output, SNR better than 90 dB
  - Accepts I<sup>2</sup>S format data
  - Programmable functions
- Surround sound
- Remote control interface for power standby on/off
- Digitally controlled echo with up to 130-ms delay
- Dual microphone input
- Clock synthesizer (PLL):
  - Based on 27-MHz crystal input
  - Generates required clocks for video encoder, audio DAC, echo and surround sound, and video processor
- Device serial communication (DSC) port for command issued/register access
- Graphical user interface (GUI) and hyperlink
- Direct CD servo control
- Vocal assist
- Remote control
- Interrupt control
- Power management
- 100-pin PQFP
- Single 5V power supply

Figure 1 shows a block diagram of a standalone system with a Visba video CD processor chip and a video CD companion chip.

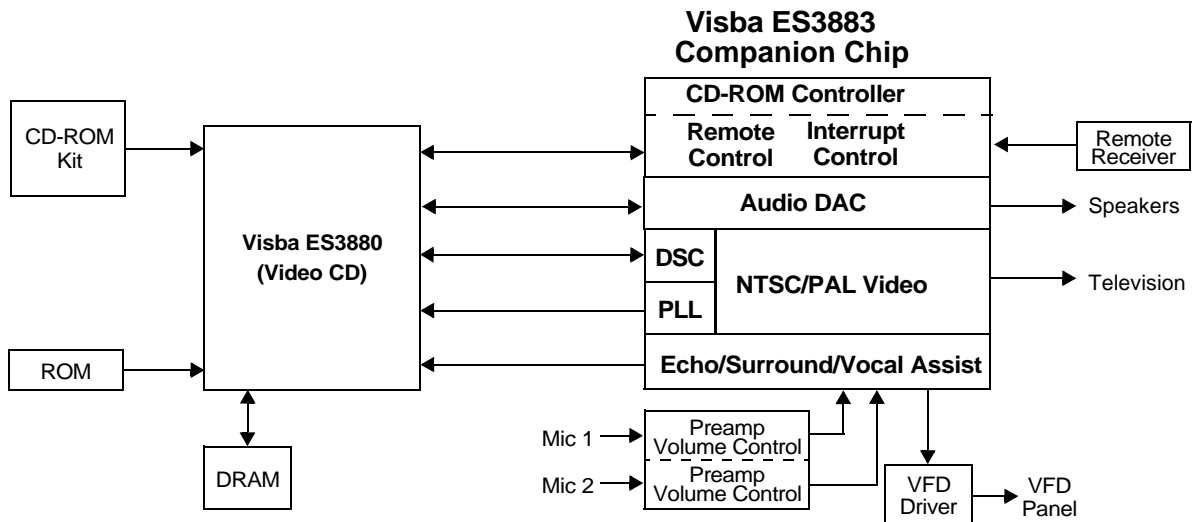

Figure 1 Visba ES3883 Video CD Companion Chip System Block Diagram

**PINOUT**

Figure 2 shows the Visba ES 3883 pinout diagram.

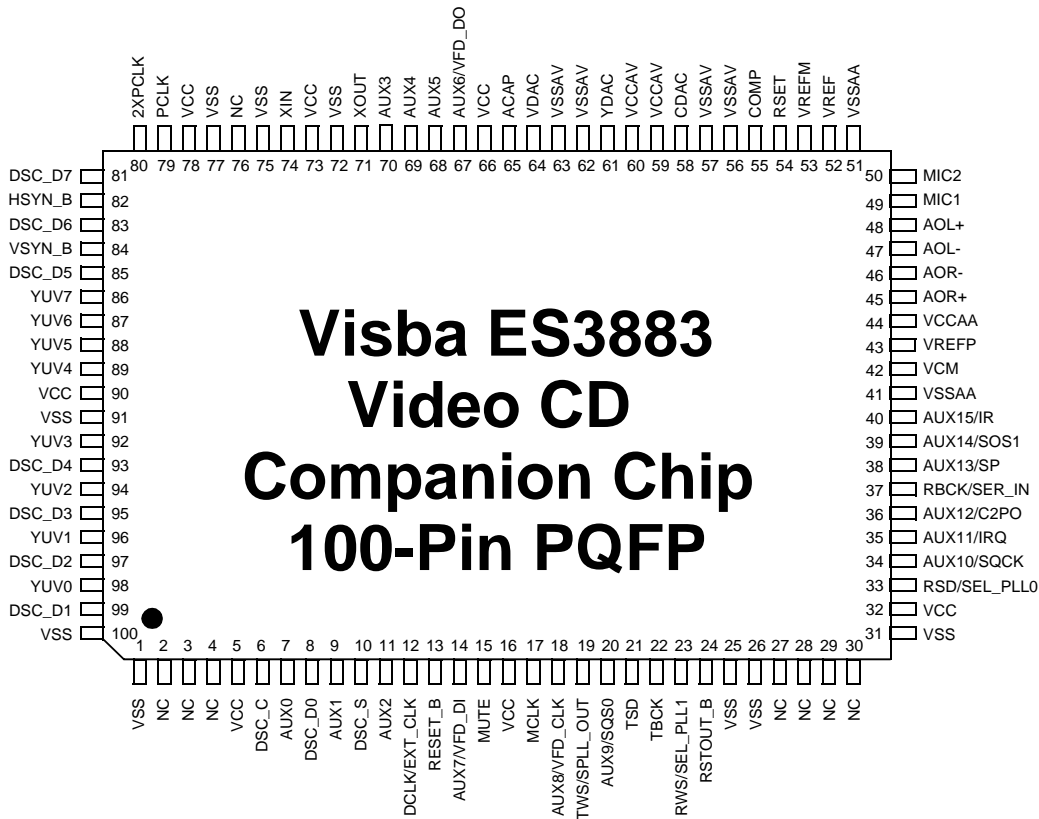

Figure 2 Visba ES883 Pinout Diagram

**VISBA ES3883 PIN DESCRIPTIONS**

Table 1 lists the Visba ES3883 pin descriptions.

Table 1 Visba ES3883 Pin Description

Name	Number	I/O	Definition
VSS	1,25,26,31,72,75,77,91,100	I	Ground.
VCC	5,16,32,66,73,78,90	I	Voltage supply, 5V.
DSC_C	6	I	Clock for programming to access internal registers.
AUX0	7	I/O	Servo forward or general-purpose I/O.
AUX1	9	I/O	Servo reverse or general-purpose I/O.
AUX2	11	I/O	Servo LDON or general-purpose I/O.
AUX3	70	I/O	Servo CW/limit or general-purpose I/O.
AUX4	69	I/O	Servo CCW/close or general-purpose I/O.
AUX5	68	I/O	Servo data or general-purpose I/O.
AUX6	67	I/O	Servo XLAT or general-purpose I/O/VFD_DO.
AUX7	14	I/O	Servo BRKM/sense or general-purpose I/O/VFD_DI.
AUX8	18	I/O	Servo mute/open or general-purpose I/O/VFD_CLK.
AUX9	20	I/O	Servo SQS0 or general-purpose I/O.
AUX10	34	I/O	Servo SQCK or general-purpose I/O.
AUX11	35	I/O	3880 IRQ or interrupt output or general-purpose I/O.
AUX12	36	I/O	CD C2PO or interrupt input or general-purpose I/O.
AUX13	38	I/O	Serial interrupt/CD-mute or general-purpose I/O.

Table 1 Visba ES3883 Pin Description (Continued)

Name	Number	I/O	Definition																
AUX14	39	I/O	Servo SCOR (S0S1), interrupt input, or general-purpose I/O.																
AUX15	40	I/O	Interrupt input or general-purpose I/O.																
DSC_D[7:0]	81,83,85,93,95,97,99,8	I/O	Data for programming to access internal registers.																
DSC_S	10	I	Strobe for programming to access internal registers.																
DCLK	12	O	Dual-purpose. DCLK is the MPEG decoder clock.																
EXT_CLK		I	EXT_CLK is the external clock. EXT_CLK is an input during bypass PLL mode.																
RESET_B	13	I	Video reset (active-low).																
MUTE	15	O	Audio mute.																
MCLK	17	I	Audio master clock.																
TWS	19	I	Dual-purpose. TWS is the transmit audio frame sync.																
SPLL_OUT		O	SPLL_OUT is the select PLL output.																
TSD	21	I	Transmit audio data input.																
TBCK	22	I	Transmit audio bit clock.																
RWS	23	O	Dual-purpose. RWS is the receive audio frame sync.																
SEL_PLL1		I	SEL_PLL[1:0] select the PLL clock frequency for the DCLK output.																
				<table border="1"> <thead> <tr> <th>SEL_PLL1</th> <th>SEL_PLL0</th> <th>DCLK</th> </tr> </thead> <tbody> <tr> <td>0</td> <td>0</td> <td>Bypass PLL (input mode)</td> </tr> <tr> <td>0</td> <td>1</td> <td>27 MHz (output mode)</td> </tr> <tr> <td>1</td> <td>0</td> <td>32.4 MHz (output mode)</td> </tr> <tr> <td>1</td> <td>1</td> <td>40.5 MHz (output mode)</td> </tr> </tbody> </table>	SEL_PLL1	SEL_PLL0	DCLK	0	0	Bypass PLL (input mode)	0	1	27 MHz (output mode)	1	0	32.4 MHz (output mode)	1	1	40.5 MHz (output mode)
SEL_PLL1		SEL_PLL0	DCLK																
0		0	Bypass PLL (input mode)																
0	1	27 MHz (output mode)																	
1	0	32.4 MHz (output mode)																	
1	1	40.5 MHz (output mode)																	
RSTOUT_B	24	O	Reset output (active-low).																
NC	2:4,27:30,76		No connect.																
RSD	33	O	Dual-purpose. RSD is the receive audio data input.																
SEL_PLL0		I	SEL_PLL0 and SEL_PLL1 select the PLL clock frequency for the DCLK output. Refer to the table for pin 23.																
RBCK	37	O	Dual-purpose. RBCK is the receive audio bit clock.																
SER_IN		I	SER_IN is the serial input DSC mode: 0 = Parallel DSC mode. 1 = Serial DSC mode.																
VSSAA	41,51	I	Audio analog ground.																
VCM	42	I	ADC common mode reference (CMR) buffer output. CMR is approximately 2.25V. Bypass to analog ground with 47- $\mu$ F electrolytic in parallel with 0.1 $\mu$ F.																
VREFP	43	I	DAC and ADC maximum reference. Bypass to video CMR (VCMR) with 10 $\mu$ F in parallel with 0.1 $\mu$ F.																
VCCAA	44	I	Analog VCC, 5V.																
AOR+, AOR-	45:46	O	Right channel output.																
AOL-, AOL+	47:48	O	Left channel output.																
MIC1	49	I	Microphone input 1.																
MIC2	50	I	Microphone input 2.																
VREF	52	I	Internal resistor divider generates CMR voltage. Bypass to analog ground with 0.1 $\mu$ F.																
VREFM	53	I	DAC and ADC minimum reference. Bypass to VCMR with 10 $\mu$ F in parallel with 0.1 $\mu$ F.																
RSET	54	I	Full-scale DAC current adjustment.																
COMP	55	I	Compensation pin.																
VSSAV	56:57,62:63	I	Video analog ground																
CDAC	58	O	Modulated chrominance output.																
VCCAV	59,60	I	Video VCC, 5V																
YDAC	61	O	Y luminance data bus for screen video port.																
VDAC	64	O	Composite video output.																
ACAP	65	I	Audio CAP																
XOUT	71	O	Crystal output.																
XIN	74	I	27-MHz crystal input.																
PCLK	79	I/O	13.5-MHz pixel clock.																
2XPCLK	80	I/O	27-MHz (2 times pixel clock).																
HSYN_B	82	O	Horizontal sync (active-low).																
VSYN_B	84	O	Vertical sync (active-low).																
YUV[7:0]	86:89,92,94,96,98	I	YUV data bus for screen video port.																

## ORDERING INFORMATION

Part Number	Description	Package
ES3883	Visba CD Companion Chip	100-pin PQFP



**ESS Technology, Inc.**  
48401 Fremont Blvd.  
Fremont, CA 94538  
Tel: (510) 492-1088  
Fax: (510) 492-1898

No part of this publication may be reproduced, stored in a retrieval system, transmitted, or translated in any form or by any means, electronic, mechanical, manual, optical, or otherwise, without the prior written permission of ESS Technology, Inc.

ESS Technology, Inc. makes no representations or warranties regarding the content of this document.

All specifications are subject to change without prior notice.

ESS Technology, Inc. assumes no responsibility for any errors contained herein.

U.S. patents pending.

Visba is a trademark of ESS Technology, Inc.

MPEG is the Moving Picture Experts Group of the ISO/IEC.

All other trademarks are owned by their respective holders and are used for identification purposes only.